



Low-Cost, Low-Voltage, Rail-to-Rail, Input/Output, SOT23 5MHz Op Amp

MAX4321

General Description

The MAX4321 operational amplifier (op amp) combines a 5MHz gain-bandwidth product and excellent DC accuracy with Rail-to-Rail® operation at both the inputs and the output. This device requires only 650 μ A and operates from either a single +2.4V to +6.5V supply or dual \pm 1.2V to \pm 3.25V supplies, although the MAX4321 typically operates down to +1.8V (\pm 0.9V). The MAX4321 remains unity-gain stable with capacitive loads up to 500pF and is capable of driving 250 Ω loads to within 200mV of either rail.

With rail-to-rail input common-mode range and output swing, the MAX4321 is ideal for low-voltage, single-supply applications. In addition, low \pm 1.2mV input offset voltage and high 2V/ μ s slew rate make this device ideal for signal-conditioning stages for precision, low-voltage data-acquisition systems. The MAX4321 comes in a space-saving 5-pin SOT23 package and is guaranteed over the extended (-40°C to +85°C) temperature range.

The MAX4321 is a low-voltage, pin-for-pin compatible upgrade for the LMC7101 that offers five-times higher bandwidth, two-times faster slew rate, and about half the input voltage noise density.

Applications

Battery-Powered Instruments
 Portable Equipment
 Data-Acquisition Systems
 Sensor and Signal Conditioning
 Low-Power, Low-Voltage Applications
 General-Purpose Low-Voltage Applications

Typical Operating Circuit

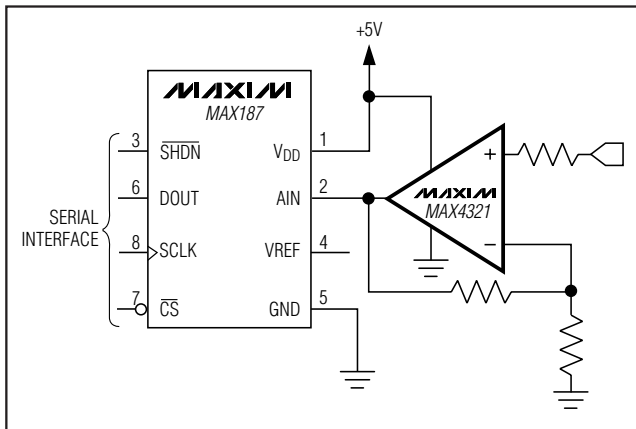

Rail-to-Rail is a registered trademark of Nippon Motorola, Ltd.

Features

- ◆ Low-Voltage, Pin-for-Pin Upgrade for LMC7101
- ◆ Guaranteed +2.4V to +6.5V Single-Supply Operation
- ◆ Typically Operates Down to +1.8V
- ◆ 5MHz Gain-Bandwidth Product
- ◆ 650 μ A Quiescent Current
- ◆ Rail-to-Rail Common-Mode Input Voltage Range
- ◆ Rail-to-Rail Output Voltage Range
- ◆ Drives 250 Ω Loads
- ◆ Unity-Gain Stable for Capacitive Loads up to 500pF
- ◆ No Phase Reversal for Overdriven Inputs
- ◆ Low-Cost Solution in SOT23-5 Package

Ordering Information

PART	TEMP. RANGE	PIN-PACKAGE	TOP MARK
MAX4321EUK-T	-40°C to +85°C	5 SOT23-5	ADOA

Pin Configuration/Functional Diagram

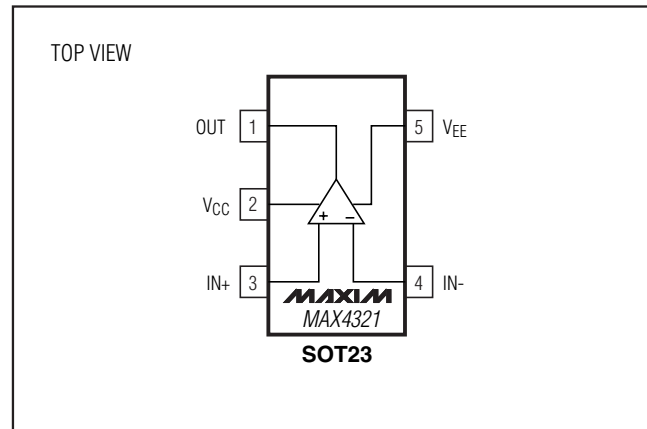

Low-Cost, Low-Voltage, Rail-to-Rail, Input/Output, SOT23 5MHz Op Amp

ABSOLUTE MAXIMUM RATINGS

Supply Voltage (V_{CC} to V_{EE})-0.3V to +7V
 All Other Pins($V_{EE} - 0.3V$) to ($V_{CC} + 0.3V$)
 Output Short-Circuit Duration.....Continuous
 (short to either supply)
 Continuous Power Dissipation ($T_A = +70^\circ\text{C}$)
 5-pin SOT23 (derate 7.1mW/ $^\circ\text{C}$ above $+70^\circ\text{C}$).....571mW

Operating Temperature Range-40 $^\circ\text{C}$ to +85 $^\circ\text{C}$
 Junction Temperature+150 $^\circ\text{C}$
 Storage Temperature Range-65 $^\circ\text{C}$ to +150 $^\circ\text{C}$
 Lead Temperature (soldering, 10s) +300 $^\circ\text{C}$

Stresses beyond those listed under "Absolute Maximum Ratings" may cause permanent damage to the device. These are stress ratings only, and functional operation of the device at these or any other conditions beyond those indicated in the operational sections of the specifications is not implied. Exposure to absolute maximum rating conditions for extended periods may affect device reliability.

DC ELECTRICAL CHARACTERISTICS

($V_{CC} = +5.0V$, $V_{EE} = 0$, $V_{CM} = 0$, $V_{OUT} = V_{CC}/2$, $R_L = \infty$ connected to $V_{CC}/2$, $T_A = +25^\circ\text{C}$, unless otherwise noted.)

PARAMETER	SYMBOL	CONDITIONS		MIN	TYP	MAX	UNITS
Supply Voltage Range	$V_{CC} - V_{EE}$			2.4		6.5	V
Supply Current		$V_{CM} = V_{OUT} = V_{CC}/2$	$V_{CC} = +2.4V$	650			μA
			$V_{CC} = +6.5V$	725			
Input Offset Voltage	V_{OS}	$V_{CM} = V_{EE}$ or V_{CC}		± 1.2		± 3.5	mV
Input Bias Current	I_{BIAS}	$V_{CM} = V_{EE}$ or V_{CC}		± 50		± 150	nA
Input Offset Current	I_{OFFSET}	$V_{CM} = V_{EE}$ or V_{CC}		± 4		± 25	nA
Differential Input Resistance	R_{IN}	$-1.5V < V_{DIFF} < +1.5V$		500			k Ω
Common-Mode Input Voltage Range	V_{CM}	Inferred from CMRR test		V_{EE}		V_{CC}	V
Common-Mode Rejection Ratio	CMRR	$V_{EE} \leq V_{CM} \leq V_{CC}$		60	91		dB
Power-Supply Rejection Ratio	PSRR	$2.4V < V_{CC} < 6.5V$		66	100		dB
Output Resistance	R_{OUT}	$A_V = +1V/V$		0.1			Ω
Large-Signal Voltage Gain	A_V	$V_{OUT} = 0.25V$ to $4.75V$, $R_L = 100k\Omega$		103			dB
		$V_{OUT} = 0.40V$ to $4.60V$, $R_L = 600\Omega$		100			
		$V_{OUT} = 0.40V$ to $4.60V$, $R_L = 250\Omega$		70	86		
Output Voltage Swing	V_{OUT}	$R_L = 100k\Omega$	$V_{CC} - V_{OH}$	25		mV	
			$V_{OL} - V_{EE}$	20			
		$R_L = 600\Omega$	$V_{CC} - V_{OH}$	135			
			$V_{OL} - V_{EE}$	60			
		$R_L = 250\Omega$	$V_{CC} - V_{OH}$	200	300		
			$V_{OL} - V_{EE}$	100	200		
Output Short-Circuit Current				50		mA	

Low-Cost, Low-Voltage, Rail-to-Rail, Input/Output, SOT23 5MHz Op Amp

MAX4321

DC ELECTRICAL CHARACTERISTICS

($V_{CC} = +5.0V$, $V_{EE} = 0$, $V_{CM} = 0$, $V_{OUT} = V_{CC}/2$, $R_L = \infty$ connected to $V_{CC}/2$, $T_A = -40^{\circ}C$ to $+85^{\circ}C$, unless otherwise noted.) (Note 1)

PARAMETER	SYMBOL	CONDITIONS	MIN	TYP	MAX	UNITS
Supply Voltage Range	$V_{CC} - V_{EE}$		2.4		6.5	V
Supply Current	I_{CC}	$V_{CM} = V_{OUT} = V_{CC}/2$			1200	μA
Input Offset Voltage	V_{OS}	$V_{CM} = V_{EE}$ or V_{CC}			± 6	mV
Input Offset Voltage Temperature Coefficient				± 2		$\mu V/^{\circ}C$
Input Bias Current	I_{BIAS}	$V_{CM} = V_{EE}$ or V_{CC}			± 180	nA
Input Offset Current	I_{OFFSET}	$V_{CM} = V_{EE}$ or V_{CC}			± 50	nA
Common-Mode Input Voltage Range	V_{CM}	Inferred from CMRR test	V_{EE}		V_{CC}	V
Common-Mode Rejection Ratio	CMRR	$V_{EE} \leq V_{CM} \leq V_{CC}$	54			dB
Power-Supply Rejection Ratio	PSRR	$2.4V < V_{CC} < 6.5V$	62			dB
Large-Signal Voltage Gain	A_V	$V_{OUT} = 0.40V$ to $4.60V$, $R_L = 250\Omega$	66			dB
Output Voltage Swing	V_{OUT}	$R = 250\Omega$			350	mV
					250	

AC ELECTRICAL CHARACTERISTICS

($V_{CC} = +5.0V$, $V_{EE} = 0$, $V_{CM} = 0$, $V_{OUT} = V_{CC}/2$, $R_L = 250\Omega$ connected to $V_{CC}/2$, $T_A = +25^{\circ}C$, unless otherwise noted.)

PARAMETER	SYMBOL	CONDITIONS	MIN	TYP	MAX	UNITS
Gain-Bandwidth Product	GBP			5		MHz
Phase Margin				64		degrees
Gain Margin				12		dB
Total Harmonic Distortion and Noise	THD+N	10kHz tone, $V_{OUT} = 2V_{pp}$, $A_V = +1V/V$		0.003		%
Slew Rate	SR	$V_{OUT} = 1V$ step		2		$V/\mu s$
Settling Time to 0.01%	t_{SETTLE}	$V_{OUT} = 2V$ step, $A_V = +1V/V$		2		μs
Turn-On Time	t_{ON}	$V_{CC} = 0$ to $3V$ step		1		μs
Input Capacitance	C_{IN}			3		pF
Input Noise Voltage Density		$f = 1kHz$		22		nV/\sqrt{Hz}
Input Noise Current Density		$f = 1kHz$		0.4		pA/\sqrt{Hz}

Note 1: All devices are 100% production tested at $T_A = +25^{\circ}C$. All temperature limits are guaranteed by design and characterization.

Low-Cost, Low-Voltage, Rail-to-Rail, Input/Output, SOT23 5MHz Op Amp

Typical Operating Characteristics

($V_{CC} = +5V$, $V_{EE} = 0$, $V_{CM} = V_{CC}/2$, $T_A = +25^\circ C$, unless otherwise noted.)

GAIN AND PHASE vs. FREQUENCY

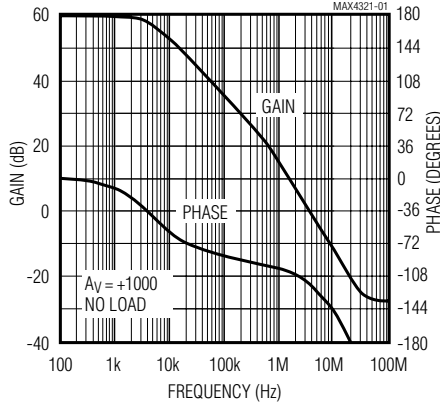

GAIN AND PHASE vs. FREQUENCY (WITH C_L)

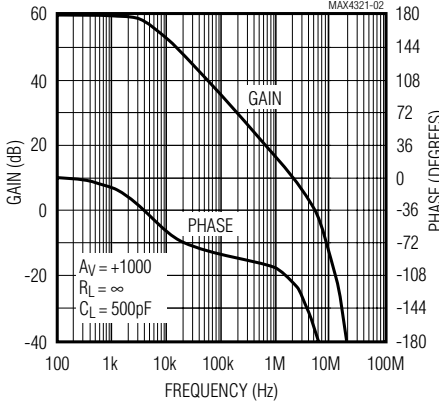

POWER-SUPPLY REJECTION vs. FREQUENCY

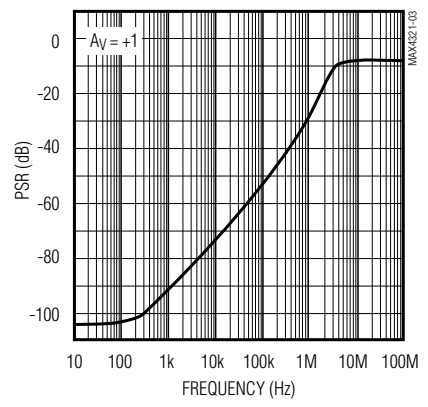

OUTPUT IMPEDANCE vs. FREQUENCY

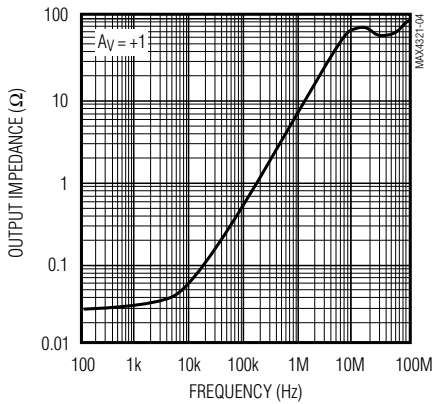

SUPPLY CURRENT vs. TEMPERATURE

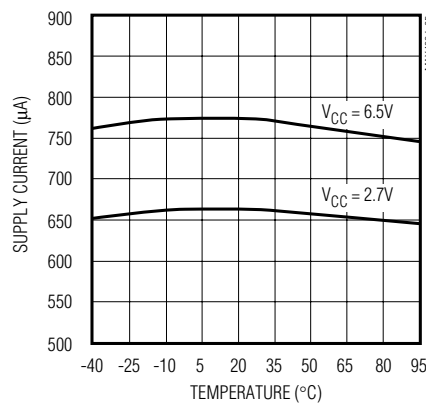

INPUT OFFSET VOLTAGE vs. TEMPERATURE

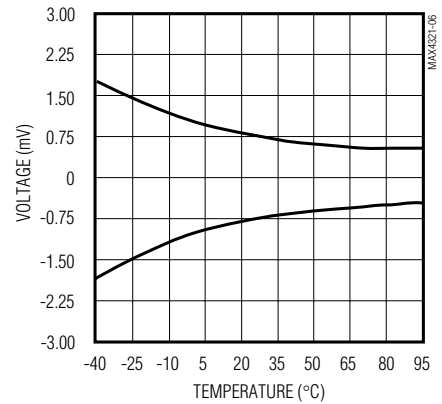

INPUT BIAS CURRENT vs. COMMON-MODE VOLTAGE

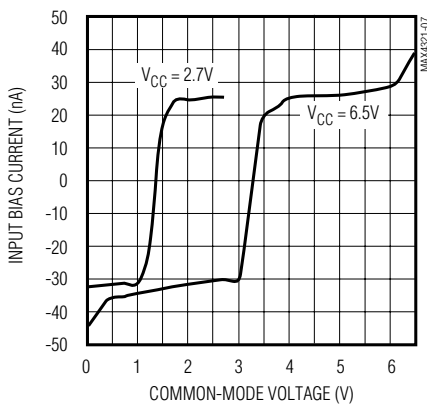

INPUT BIAS CURRENT vs. TEMPERATURE

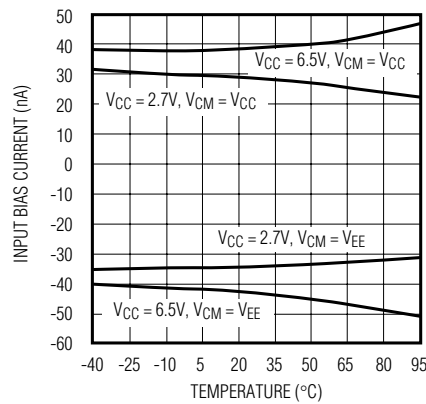

COMMON-MODE REJECTION vs. TEMPERATURE

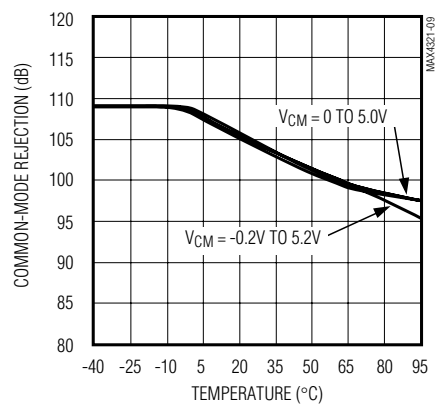

Low-Cost, Low-Voltage, Rail-to-Rail, Input/Output, SOT23 5MHz Op Amp

MAX4321

Typical Operating Characteristics (continued)

($V_{CC} = +5V$, $V_{EE} = 0$, $V_{CM} = V_{CC}/2$, $T_A = +25^\circ C$, unless otherwise noted.)

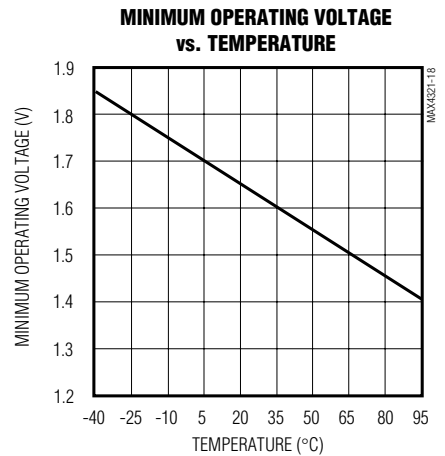
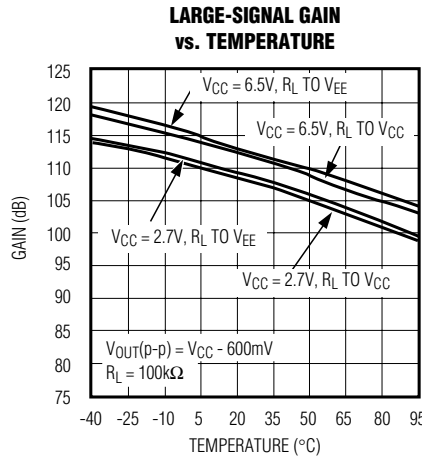
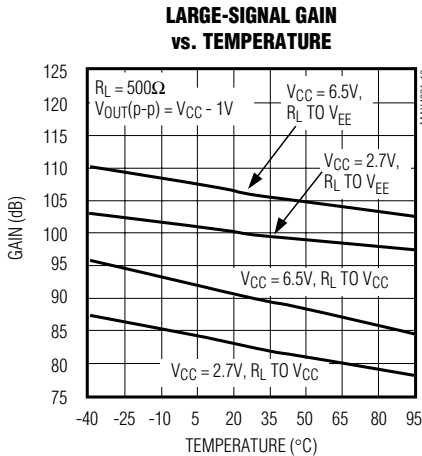
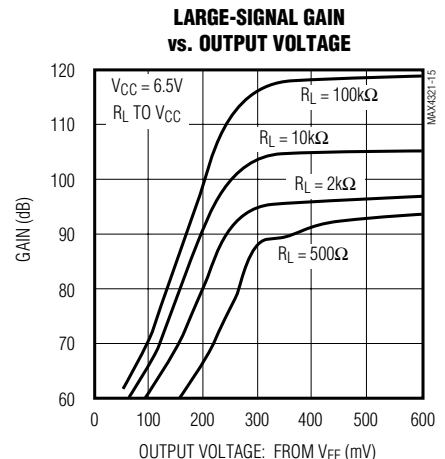
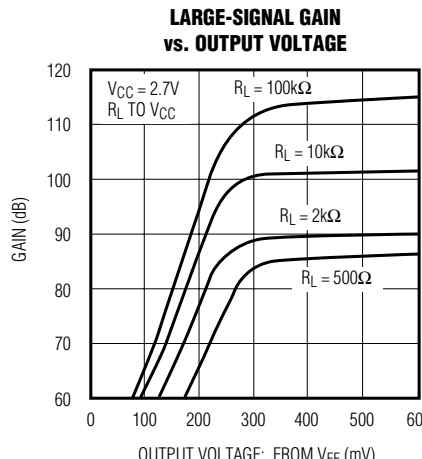
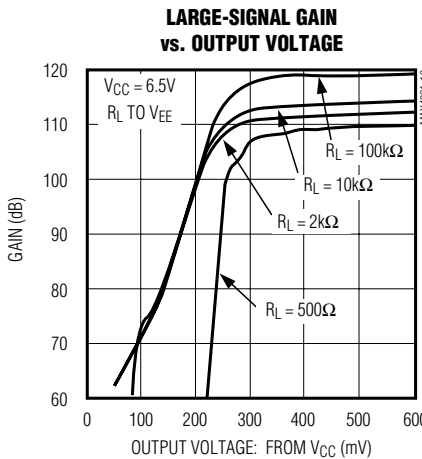
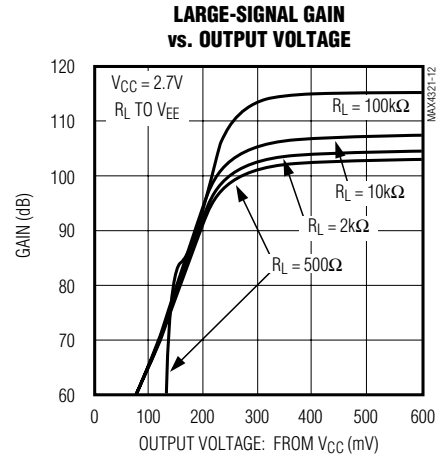
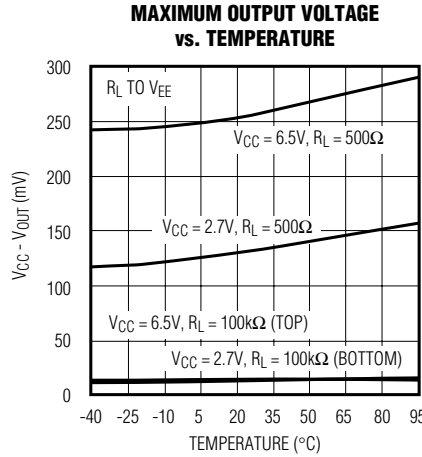
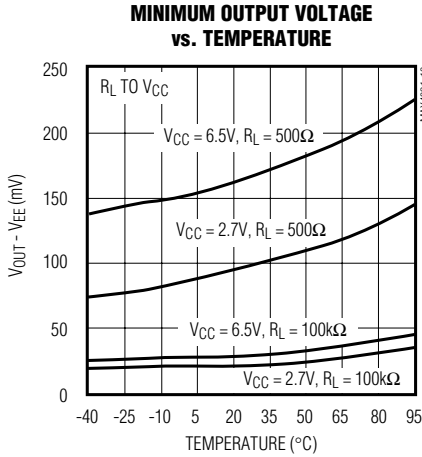

Low-Cost, Low-Voltage, Rail-to-Rail, Input/Output, SOT23 5MHz Op Amp

Typical Operating Characteristics (continued)

($V_{CC} = +5V$, $V_{EE} = 0$, $V_{CM} = V_{CC}/2$, $T_A = +25^\circ C$, unless otherwise noted.)

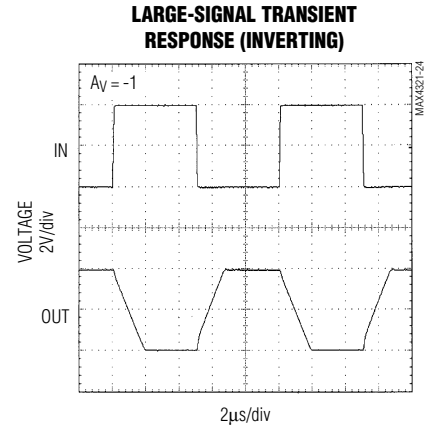
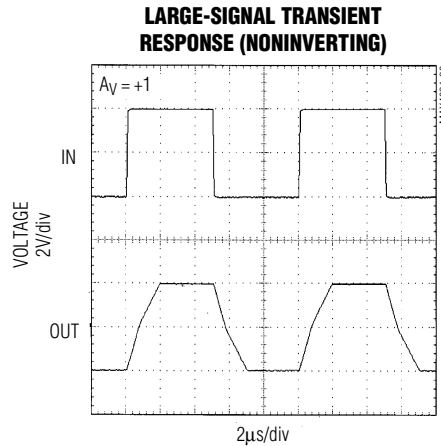
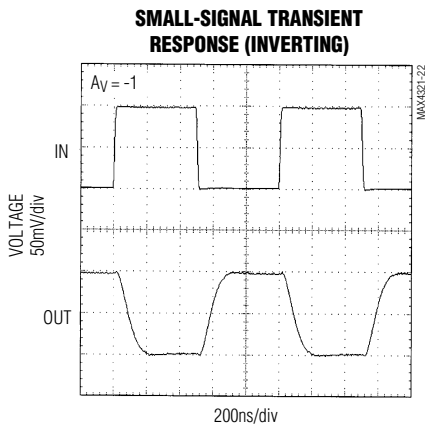
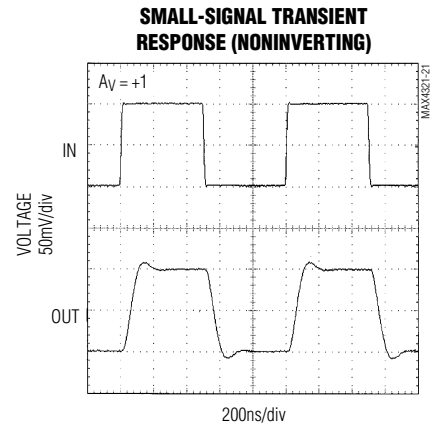
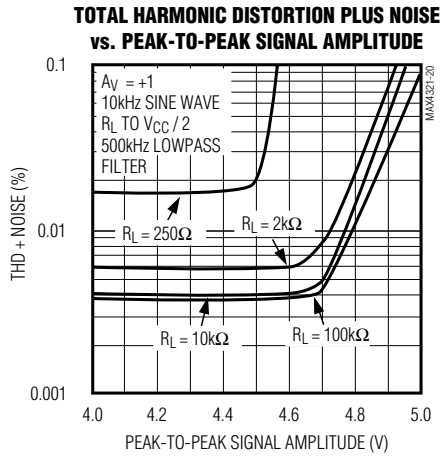
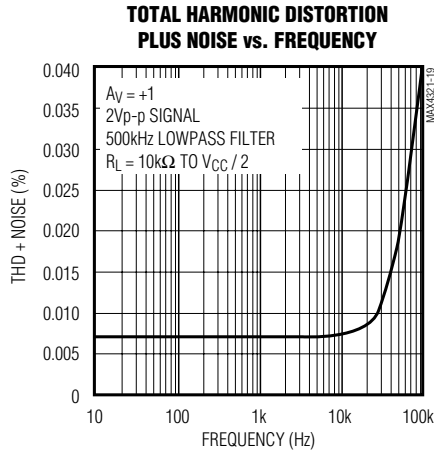

Pin Description

PIN	NAME	FUNCTION
1	OUT	Output
2	V_{CC}	Positive Supply
3	IN+	Noninverting Input
4	IN-	Inverting Input
5	V_{EE}	Negative Supply. Connect to ground for single-supply operation.

Low-Cost, Low-Voltage, Rail-to-Rail, Input/Output, SOT23 5MHz Op Amp

MAX4321

Applications Information

Rail-to-Rail Input Stage

The MAX4321 high-speed amplifier has rail-to-rail input and output stages designed for low-voltage, single-supply operation. The input stage consists of separate NPN and PNP differential stages, which combine to provide an input common-mode range extending to the supply rails. The PNP stage is active for input voltages close to the negative rail, and the NPN stage is active for input voltages near the positive rail. The switchover transition region, which occurs near $V_{CC} / 2$, has been extended to minimize the slight degradation in CMRR caused by the mismatch of the input pairs. Its low offset voltage, high bandwidth, and rail-to-rail common-mode range makes this op amp an excellent choice for precision, low-voltage, data-acquisition systems.

Since the input stage switches between the NPN and PNP pairs, the input bias current changes polarity as the input voltage passes through the transition region. To reduce the offset error caused by input bias cur-

rents flowing through external source impedances, match the effective impedance seen by each input (Figures 1a, 1b). High source impedances, together with the input capacitance, can create a parasitic pole that produces an underdamped signal response. Reducing the input impedance or placing a small (2pF to 10pF) capacitor across the feedback resistor improves the response.

The MAX4321's inputs are protected from large differential input voltages by 1k Ω series resistors and back-to-back triple diodes across the inputs (Figure 2). For differential input voltages less than 1.8V, the input resistance is typically 500k Ω . For differential input voltages greater than 1.8V, the input resistance is approximately 2k Ω , and the input bias current is determined by the following equation:

$$I_{BIAS} = \frac{V_{DIFF} - 1.8V}{2k\Omega}$$

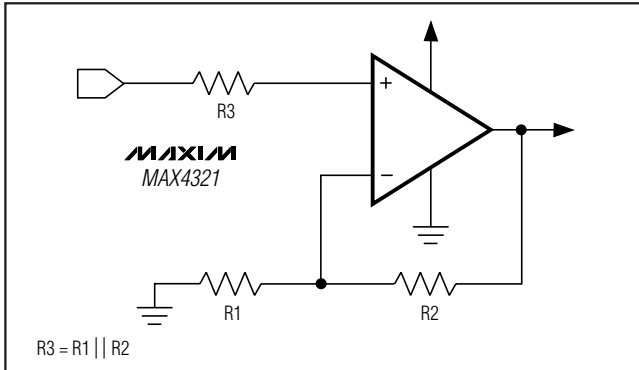

Figure 1a. Reducing Offset Error Due to Bias Current (Noninverting)

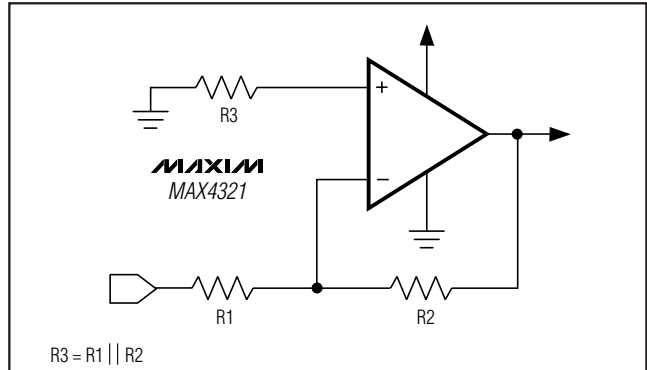

Figure 1b. Reducing Offset Error Due to Bias Current (Inverting)

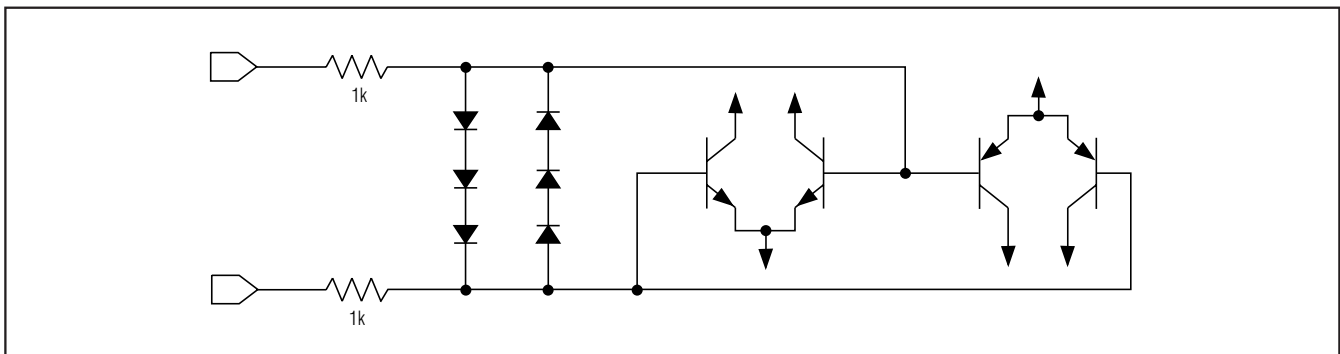

Figure 2. Input Protection Circuit

Low-Cost, Low-Voltage, Rail-to-Rail, Input/Output, SOT23 5MHz Op Amp

Rail-to-Rail Output Stage

The minimum output voltage will be within millivolts of ground for single-supply operation where the load is referenced to ground (V_{EE}). Figure 3 shows the input voltage range and output voltage swing of a MAX4321 connected as a voltage follower. With a +3V supply and the 100k Ω load tied to ground, the output swings from 0.02V to 2.97V. The maximum output voltage swing depends on the load but will be within 300mV of a +5V supply, even with the maximum load (250 Ω to ground).

Driving a capacitive load can cause instability in most high-speed op amps, especially those with low quiescent current. The MAX4321 has a high tolerance for capacitive loads. It is stable with capacitive loads up to 500pF. Figure 4 gives the stable operating region for capacitive loads. Figures 5 and 6 show the response with capacitive loads and the results of adding an isolation resistor in series with the output (Figure 7). The resistor improves the circuit's phase margin by isolating the load capacitor from the op amp's output.

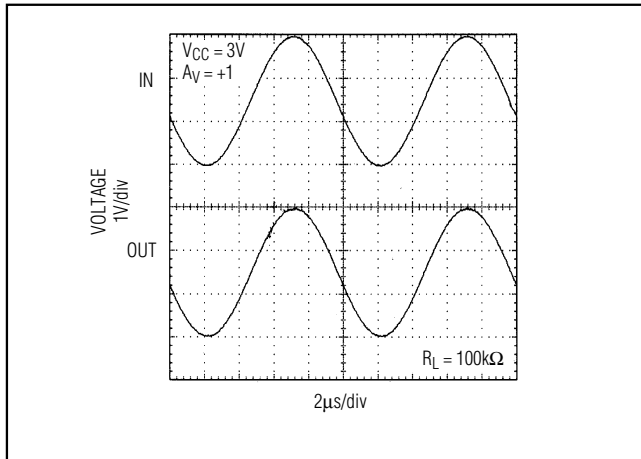

Figure 3. Rail-to-Rail Input /Output Voltage Range

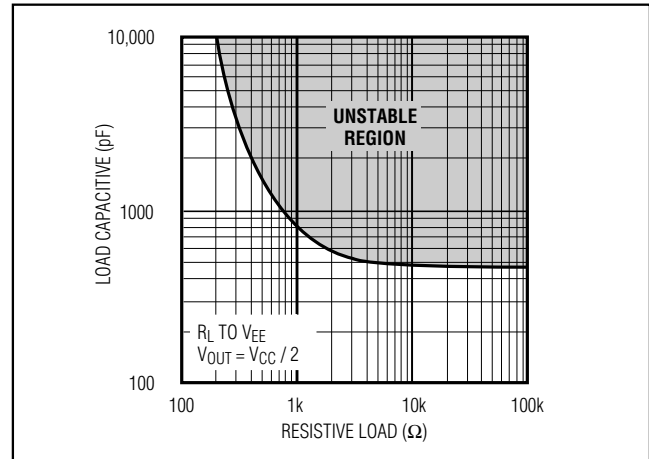

Figure 4. Capacitive-Load Stability

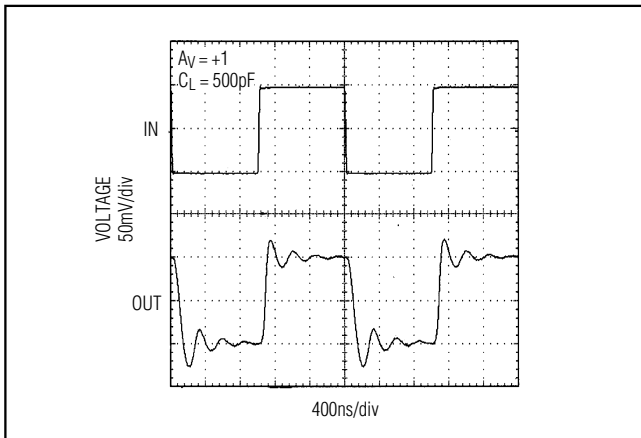

Figure 5. Small-Signal Transient Response with Capacitive Load

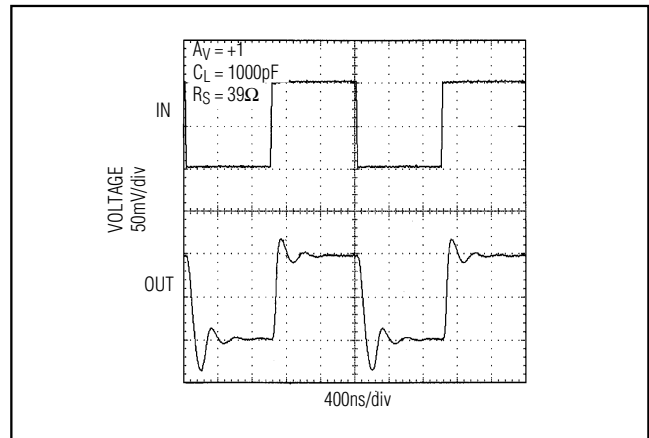

Figure 6. Transient Response to Capacitive Load with Isolation Resistor

Low-Cost, Low-Voltage, Rail-to-Rail, Input/Output, SOT23 5MHz Op Amp

MAX4321

Power-Up

The MAX4321 typically settles within 1 μ s after power-up. Using the test circuit of Figure 8, Figures 9 and 10 show the output voltage and supply current on power-up.

Power Supplies and Layout

The MAX4321 operates from single +2.4V to +6.5V or dual \pm 1.2V to \pm 3.25V supplies, though it typically operates down to +1.8V (\pm 0.9V). For single-supply operation, bypass the power supply with a 0.1 μ F ceramic capacitor in parallel with at least 1 μ F. For dual supplies, bypass each supply to ground.

Good layout improves performance by decreasing the amount of stray capacitance at the op amp's inputs and outputs. To decrease stray capacitance, minimize trace lengths and resistor leads by placing external components close to the op amp's pins.

Package Information

TRANSISTOR COUNT: 84

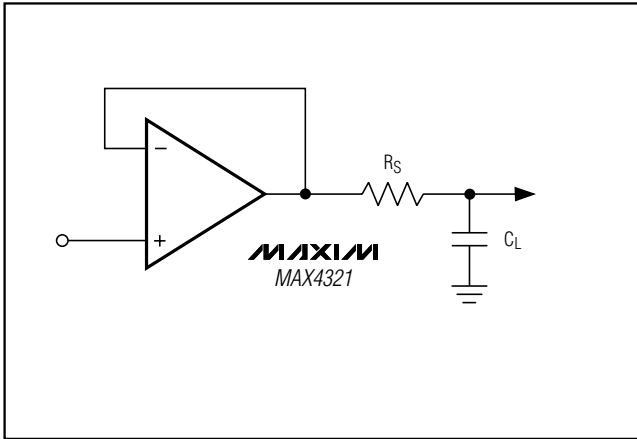

Figure 7. Capacitive-Load-Driving Circuit

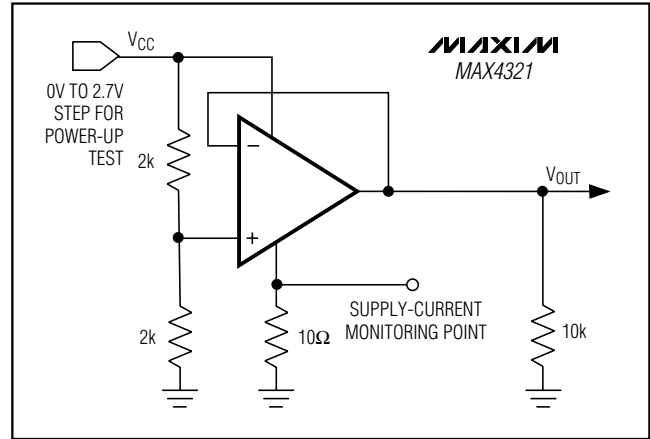

Figure 8. Power-Up Test Circuit

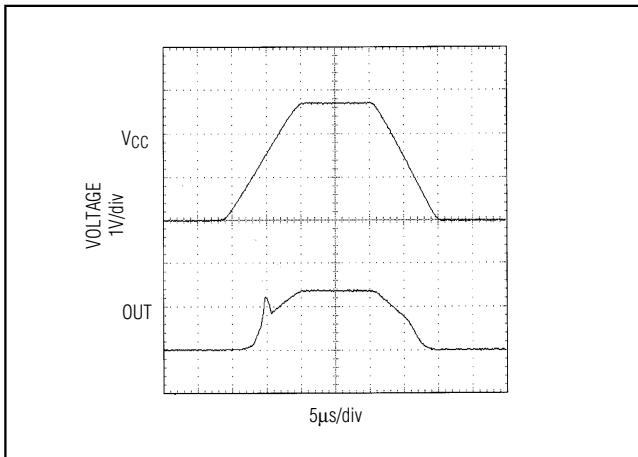

Figure 9. Power-Up Output Voltage

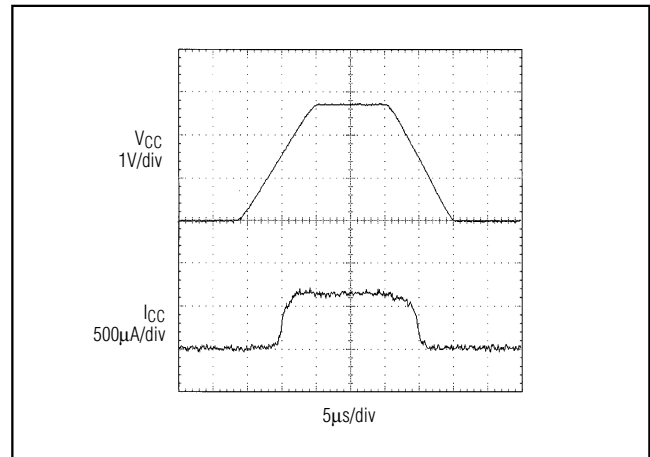
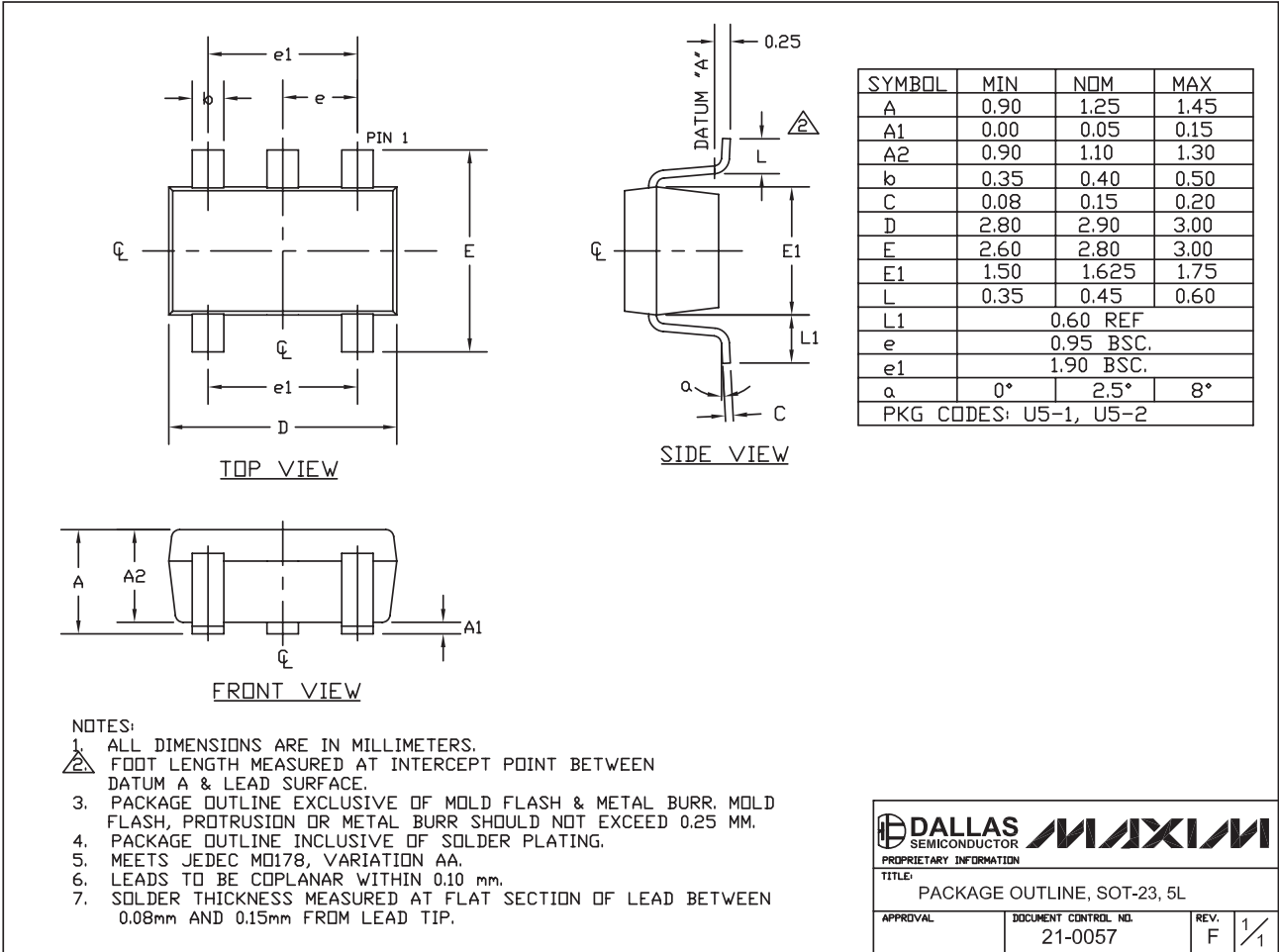

Figure 10. Power-Up Supply Current

Low-Cost, Low-Voltage, Rail-to-Rail, Input/Output, SOT23 5MHz Op Amp

Package Information



SOT-23 5L EPS

DALLAS SEMICONDUCTOR **MAXIM**
 PROPRIETARY INFORMATION
 TITLE: PACKAGE OUTLINE, SOT-23, 5L
 APPROVAL: DOCUMENT CONTROL NO. 21-0057 REV. F 1/1

**Low-Cost, Low-Voltage, Rail-to-Rail,
Input/Output, SOT23 5MHz Op Amp**

NOTES

MAX4321

MAX4321

Low-Cost, Low-Voltage, Rail-to-Rail, Input/Output, SOT23 5MHz Op Amp

NOTES

Maxim cannot assume responsibility for use of any circuitry other than circuitry entirely embodied in a Maxim product. No circuit patent licenses are implied. Maxim reserves the right to change the circuitry and specifications without notice at any time.

12 _____ **Maxim Integrated Products, 120 San Gabriel Drive, Sunnyvale, CA 94086 408-737-7600**

© 2000 Maxim Integrated Products

MAXIM is a registered trademark of Maxim Integrated Products, Inc.

Looking for pricing, stock, or lifecycle information?

Click below to explore more details on WIN SOURCE:

 [View MAX4321EUK-T on WIN SOURCE](#)

 [Maxim Integrated](#) Information

Optimize Your Supply Chain with WIN SOURCE Solutions

-  Global Sourcing Solution
-  Obsolete Management
-  Cost Control Management
-  Shortage Management
-  Alternative Solution
-  Excess Inventory Management