



THE DATASHEET OF MAX4073FAUT



Low-Cost, SC70, Voltage-Output, High-Side Current-Sense Amplifier

General Description

The MAX4073 low-cost, high-side current-sense amplifier features a voltage output that eliminates the need for gain-setting resistors making it ideal for cell phones, notebook computers, PDAs, and other systems where current monitoring is crucial. High-side current monitoring does not interfere with the ground path of the battery charger making the MAX4073 particularly useful in battery-powered systems. The input common-mode range of +2V to +28V is independent of the supply voltage. The MAX4073's wide 1.8MHz bandwidth makes it suitable for use inside battery-charger control loops.

The combination of three gain versions and a selectable external-sense resistor sets the full-scale current reading. The MAX4073 offers a high level of integration, resulting in a simple and compact current-sense solution.

The MAX4073 operates from a +3V to +28V single supply and draws only 0.5mA of supply current. This device is specified over the automotive operating temperature range (-40°C to +125°C) and is available in a space-saving 5-pin SC70 package (half the size of the SOT23).

For a similar device in a 6-pin SOT23 with a wider common-mode voltage range (0 to +28V), see the MAX4173 data sheet.

Applications

- Cell Phones
- Notebook Computers
- Portable/Battery-Powered Systems
- Smart Battery Packs/Chargers
- PDAs
- Power Management Systems
- PA Bias Control
- General System/Board-Level Current Monitoring
- Precision Current Sources

Features

- ◆ Low-Cost, Compact, Current-Sense Solution
- ◆ Three Gain Versions Available
 - +20V/V (MAX4073T)
 - +50V/V (MAX4073F)
 - +100V/V (MAX4073H)
- ◆ ±1.0% Full-Scale Accuracy
- ◆ 500µA Supply Current
- ◆ Wide 1.8MHz Bandwidth
- ◆ +3V to +28V Operating Supply
- ◆ Wide +2V to +28V Common-Mode Range Independent of Supply Voltage
- ◆ Automotive Temperature Range (-40°C to +125°C)
- ◆ Available in Space-Saving 5-Pin SC70 Package

Typical Operating Circuit

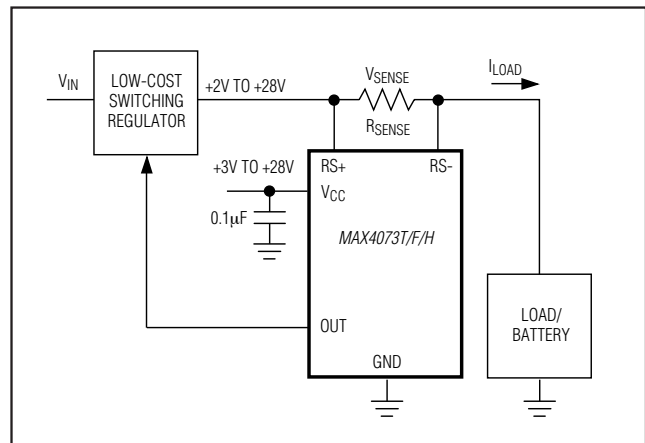

Pin Configurations appear at end of data sheet.

Ordering Information

PART	TEMP. RANGE	PIN-PACKAGE	GAIN (V/V)	TOP MARK
MAX4073TAXK+T	-40°C to +125°C	5 SC70	20	ACM
MAX4073TAUT+T	-40°C to +125°C	6 SOT23	20	AAUE
MAX4073FAXK+T	-40°C to +125°C	5 SC70	50	ACN
MAX4073FAUT+T	-40°C to +125°C	6 SOT23	50	AAUF
MAX4073HAXK+T	-40°C to +125°C	5 SC70	100	ACO
MAX4073HAUT+T	-40°C to +125°C	6 SOT23	100	AAUG

+Denotes lead(Pb)-free/RoHS-compliant package.

For pricing, delivery, and ordering information, please contact Maxim Direct at 1-888-629-4642, or visit Maxim's website at www.maximintegrated.com.

MAX4073T/F/H

Low-Cost, SC70, Voltage-Output, High-Side Current-Sense Amplifier

ABSOLUTE MAXIMUM RATINGS

V _{CC} to GND	-0.3V to +30V
RS+, RS- to GND	-0.3V to +30V
OUT to GND	-0.3V to (V _{CC} + 0.3V)
Output Short-Circuit to GND	Continuous
Differential Input Voltage (V _{RS+} - V _{RS-})	±5V
Current Into Any Pin	±20mA
Continuous Power Dissipation (T _A = +70°C)	
5-Pin SC70 (derate 2.27mW/°C above +70°C)	200mW
6-Pin SOT23 (derate 8.7mW/°C above +70°C)	696mW

Operating Temperature Range	-40°C to +125°C
Junction Temperature	+150°C
Storage Temperature Range	-65°C to +150°C
Lead Temperature (soldering, 10s)	+300°C
Soldering Temperature	+260°C

Stresses beyond those listed under "Absolute Maximum Ratings" may cause permanent damage to the device. These are stress ratings only, and functional operation of the device at these or any other conditions beyond those indicated in the operational sections of the specifications is not implied. Exposure to absolute maximum rating conditions for extended periods may affect device reliability.

ELECTRICAL CHARACTERISTICS

(V_{RS+} = +2V to +28V, V_{SENSE} = (V_{RS+} - V_{RS-}) = 0, V_{CC} = +3V to +28V, T_A = T_{MIN} to T_{MAX}, unless otherwise noted. Typical values are at T_A = +25°C.) (Note 1)

PARAMETER	SYMBOL	CONDITIONS	MIN	TYP	MAX	UNITS
Operating Voltage Range	V _{CC}	(Note 2)	3		28	V
Common-Mode Input Range	V _{CMR}	(Note 3)	2		28	V
Common-Mode Rejection	CMR	V _{SENSE} = 100mV, V _{CC} = 12V		90		dB
Supply Current	I _{CC}	V _{CC} = 28V		0.5	1.2	mA
Leakage Current	I _{RS+} /I _{RS-}	V _{CC} = 0V, V _{RS+} = 28V		0.05	1	μA
Input Bias Current	I _{RS+}			20	60	μA
	I _{RS-}			40	120	
Full-Scale Sense Voltage	V _{SENSE}	V _{SENSE} = (V _{RS+} - V _{RS-})		150		mV
Total OUT Voltage Error (Note 4)		V _{SENSE} = 100mV, V _{CC} = 12V, V _{RS+} = 2V		±1.0		%
		V _{SENSE} = 100mV, V _{CC} = 12V, V _{RS+} = 12V, T _A = +25°C		±1.0	±5.0	
		V _{SENSE} = 100mV, V _{CC} = 12V, V _{RS+} = 12V, T _A = T _{MIN} to T _{MAX}			±7.0	
		V _{SENSE} = 100mV, V _{CC} = 28V, V _{RS+} = 28V, T _A = +25°C		±1.0	±5.0	
		V _{SENSE} = 100mV, V _{CC} = 28V, V _{RS+} = 28V, T _A = T _{MIN} to T _{MAX}			±8.5	
		V _{SENSE} = 6.25mV (Note 5); V _{CC} = 12V, V _{RS+} = 12V		±7.5		
Extrapolated Input Offset Voltage	V _{OS}	V _{CC} = V _{RS+} = 12V, V _{SENSE} > 10mV		1.0		mV
OUT High Voltage	(V _{CC} - V _{OH})	V _{SENSE} = 150mV	MAX4073T, V _{CC} = 3V	0.8	1.2	V
			MAX4073F, V _{CC} = 7.5V			
			MAX4073H, V _{CC} = 15V			

MAX4073T/F/H

Low-Cost, SC70, Voltage-Output, High-Side Current-Sense Amplifier

ELECTRICAL CHARACTERISTICS (continued)

($V_{RS+} = +2V$ to $+28V$, $V_{SENSE} = (V_{RS+} - V_{RS-}) = 0$, $V_{CC} = +3V$ to $+28V$, $T_A = T_{MIN}$ to T_{MAX} , unless otherwise noted. Typical values are at $T_A = +25^\circ C$.) (Note 1)

PARAMETER	SYMBOL	CONDITIONS		MIN	TYP	MAX	UNITS
Bandwidth	BW	$V_{CC} = 12V$, $V_{RS+} = 12V$, $C_{LOAD} = 5pF$	MAX4073T, $V_{SENSE} = 100mV$		1.8		MHz
			MAX4073F, $V_{SENSE} = 100mV$		1.7		
			MAX4073H, $V_{SENSE} = 100mV$		1.6		
			MAX4073T/F/H $V_{SENSE} = 6.25mV$ (Note 5)		600		kHz
Gain	AV	MAX4073T			20		V/V
		MAX4073F			50		
		MAX4073H			100		
Gain Accuracy	ΔAV	$V_{CC} = 12V$, $V_{RS+} = 12V$, $V_{SENSE} = 10mV$ to $150mV$, MAX4073T/F	$T_A = +25^\circ C$		± 1.0	± 4.5	%
			$T_A = T_{MIN}$ to T_{MAX}			± 6.5	
		$V_{CC} = 12V$, $V_{RS+} = 12V$, $V_{SENSE} = 10mV$ to $100mV$, MAX4073H	$T_A = +25^\circ C$		± 1.0	± 4.5	
			$T_A = T_{MIN}$ to T_{MAX}			± 6.5	
OUT Settling Time to 1% of Final Value		$V_{CC} = 12V$, $V_{RS+} = 12V$, $C_{LOAD} = 5pF$	$V_{SENSE} = 6.25mV$ to $100mV$		400		ns
			$V_{SENSE} = 100mV$ to $6.25mV$		800		
Output Resistance	R_{OUT}				12		$k\Omega$
Power-Supply Rejection Ratio	PSRR	$V_{CC} = 3V$ to $28V$	$V_{SENSE} = 60mV$, MAX4073T	70	78		dB
			$V_{SENSE} = 24mV$, MAX4073F	70	85		
			$V_{SENSE} = 12mV$, MAX4073H	70	90		
Power-Up Time (Note 6)		$C_{LOAD} = 5pF$, $V_{SENSE} = 100mV$			5		μs
Saturation Recovery Time (Note 7)		$V_{CC} = 12V$, $V_{RS+} = 12V$, $C_{LOAD} = 5pF$			5		μs

Note 1: All devices are 100% production tested at $T_A = +25^\circ C$. All temperature limits are guaranteed by design.

Note 2: Inferred from PSRR test.

Note 3: Inferred from OUT Voltage Error test.

Note 4: Total OUT Voltage Error is the sum of the gain and offset errors.

Note 5: $6.25mV = 1/16$ of $100mV$ full-scale sense voltage.

Note 6: Output settles to within 1% of final value.

Note 7: The device will not experience phase reversal when overdriven.

MAX4073T/F/H

Low-Cost, SC70, Voltage-Output, High-Side Current-Sense Amplifier

Typical Operating Characteristics

($V_{CC} = +12V$, $V_{RS+} = +12V$, $V_{SENSE} = 100mV$, $C_L = 5pF$, $T_A = +25^{\circ}C$, unless otherwise noted.)

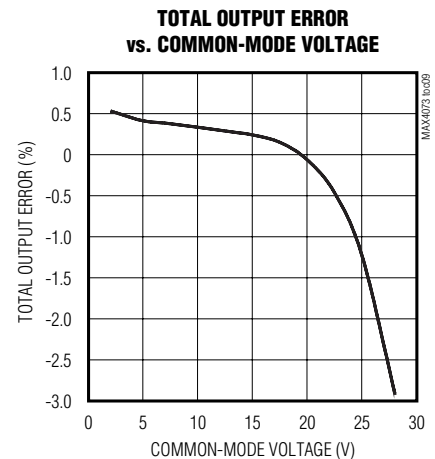
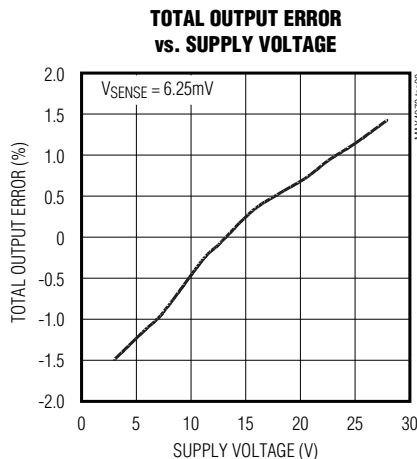
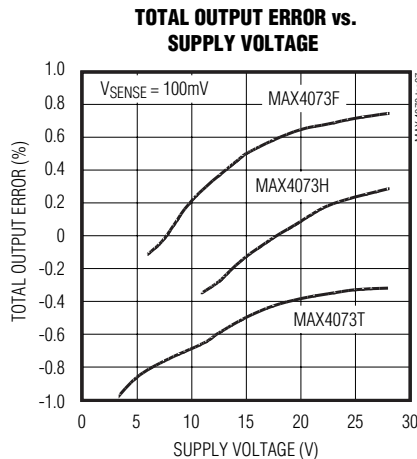
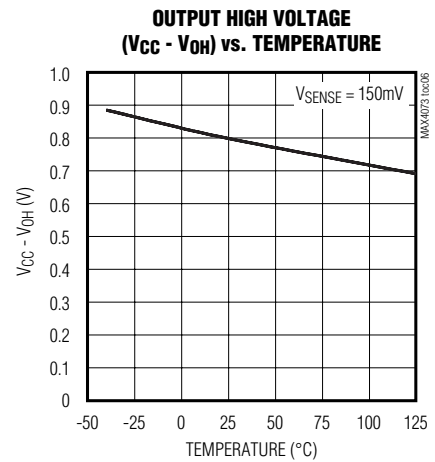
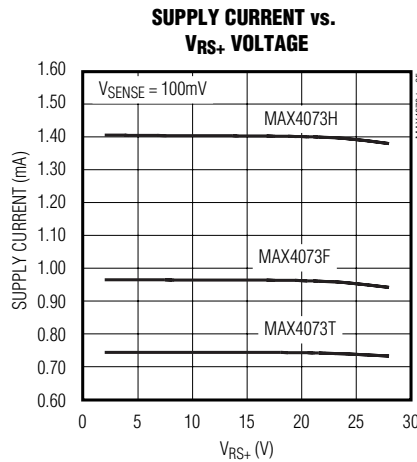
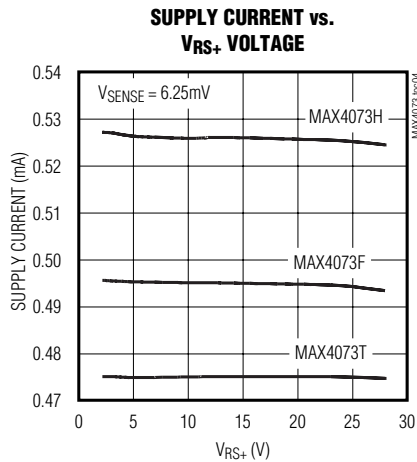
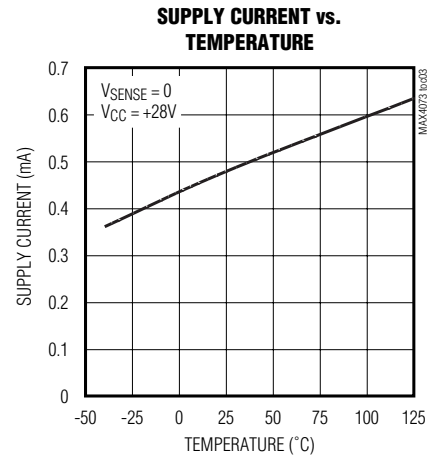
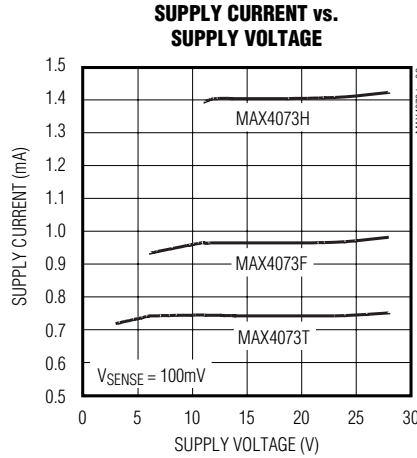
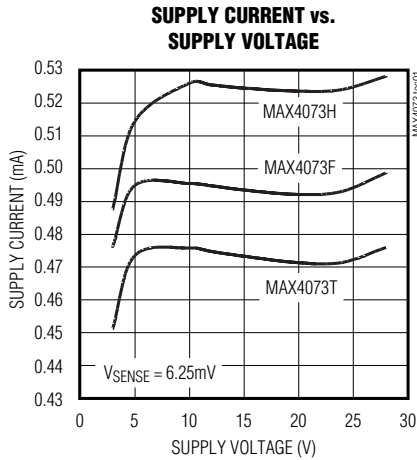

MAX4073T/F/H

Low-Cost, SC70, Voltage-Output, High-Side Current-Sense Amplifier

Typical Operating Characteristics (continued)

($V_{CC} = +12V$, $V_{RS+} = +12V$, $V_{SENSE} = 100mV$, $C_L = 5pF$, $T_A = +25^{\circ}C$, unless otherwise noted.)

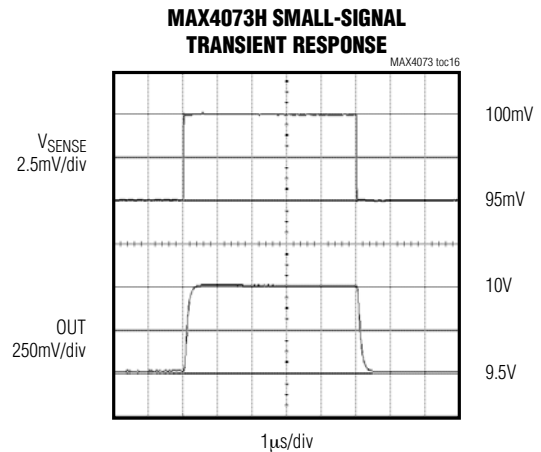
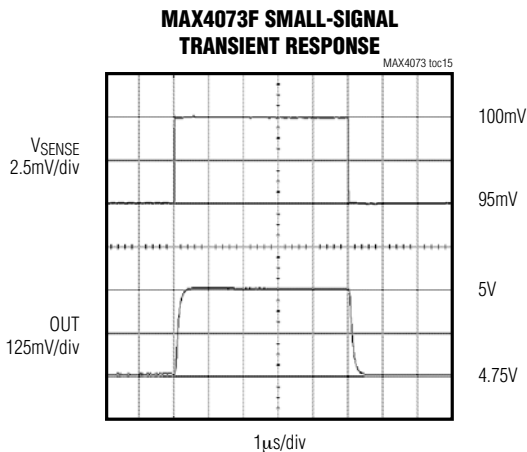
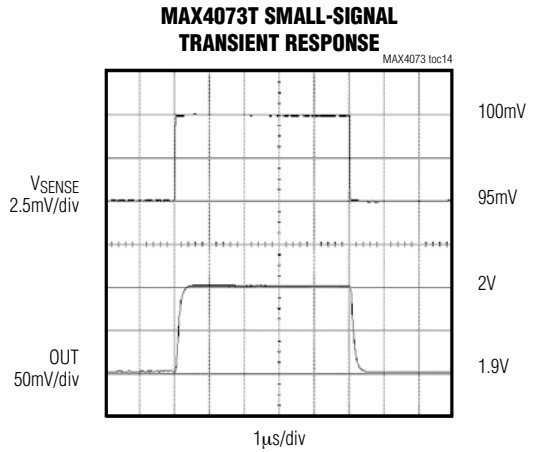
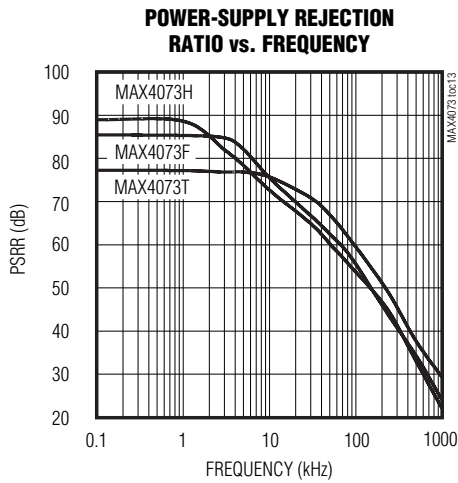
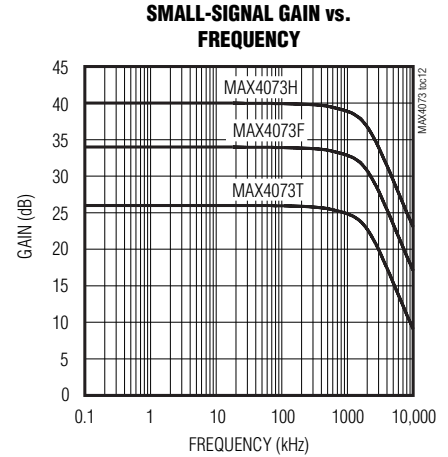
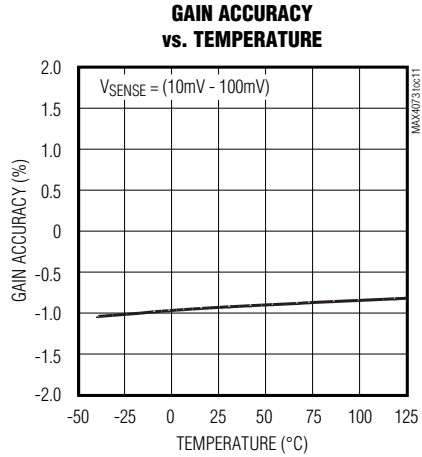
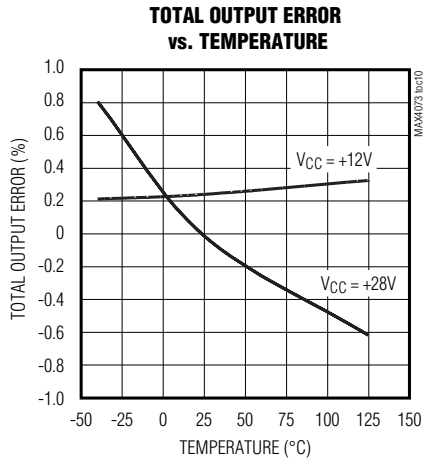

MAX4073T/F/H

Low-Cost, SC70, Voltage-Output, High-Side Current-Sense Amplifier

Typical Operating Characteristics (continued)

($V_{CC} = +12V$, $V_{RS+} = +12V$, $V_{SENSE} = 100mV$, $C_L = 5pF$, $T_A = +25^{\circ}C$, unless otherwise noted.)

MAX4073T LARGE-SIGNAL TRANSIENT RESPONSE

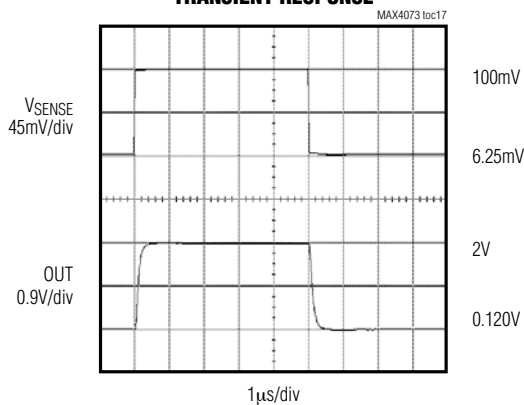

MAX4073F LARGE-SIGNAL TRANSIENT RESPONSE

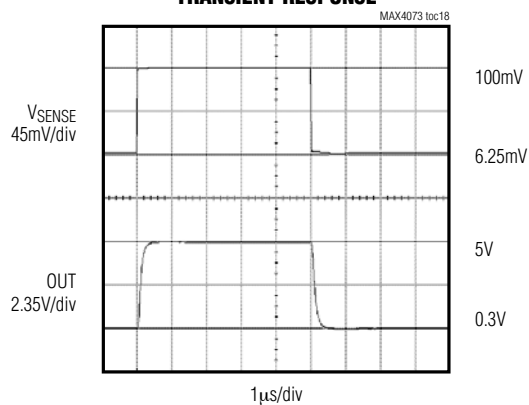

MAX4073H LARGE-SIGNAL TRANSIENT RESPONSE

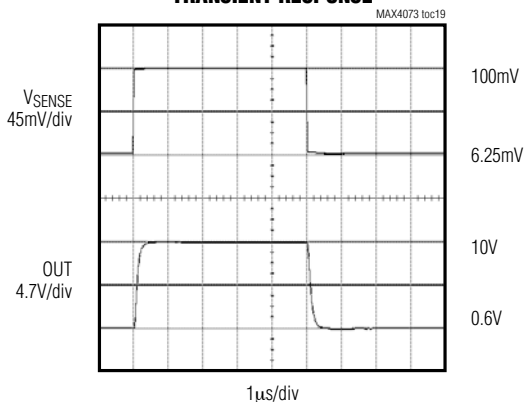

MAX4073T OVERDRIVE RESPONSE

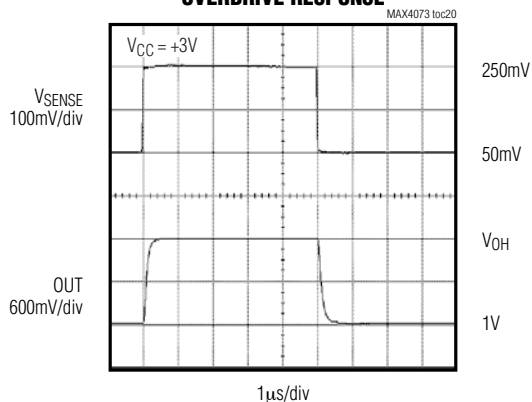

MAX4073T STARTUP DELAY

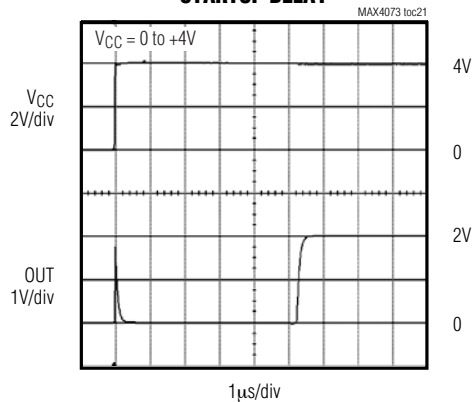

MAX4073T/F/H

Low-Cost, SC70, Voltage-Output, High-Side Current-Sense Amplifier

Pin Description

PIN		NAME	FUNCTION
SOT23	SC70		
1, 2	2	GND	Ground
3	3	VCC	Supply Voltage Input. Bypass to GND with a 0.1µF capacitor.
4	4	RS+	Power-Side Connection to the External Sense Resistor
5	5	RS-	Load-Side Connection to the External Sense Resistor
6	1	OUT	Voltage Output. V _{OUT} is proportional to V _{SENSE} . Output impedance is approximately 12kΩ.

Detailed Description

The MAX4073 high-side current-sense amplifier features a +2V to +28V input common-mode range that is independent of supply voltage. This feature allows the monitoring of current out of a battery as low as +2V and also enables high-side current sensing at voltages greater than the supply voltage (V_{CC}).

The MAX4073 operates as follows: current from the source flows through R_{SENSE} to the load (Figure 1). Since the internal-sense amplifier's inverting input has high impedance, negligible current flows through R_{G2} (neglecting the input bias current). Therefore, the sense amplifier's inverting-input voltage equals V_{SOURCE} - (I_{LOAD})(R_{SENSE}). The amplifier's open-loop gain forces its noninverting input to the same voltage as the inverting input. Therefore, the drop across R_{G1} equals (I_{LOAD})(R_{SENSE}). Since I_{RG1} flows through R_{G1}, I_{RG1} = (I_{LOAD})(R_{SENSE}) / R_{G1}. The internal current mirror multiplies I_{RG1} by a current gain factor, β, to give I_{RGD} = β × I_{RG1}. Solving I_{RGD} = β × (I_{LOAD})(R_{SENSE}) / R_{G1}. Assuming infinite output impedance, V_{OUT} = (I_{RGD})(R_{G2}). Substituting in for I_{RGD} and rearranging, V_{OUT} = β × (R_{G2}/R_{G1})(R_{SENSE} × I_{LOAD}). The parts gain equals β × R_{G2}/R_{G1}. Therefore, V_{OUT} = (GAIN) (R_{SENSE}) (I_{LOAD}), where GAIN = 20V/V for MAX4073T, GAIN = 50V/V for MAX4073F, and GAIN = 100V/V for MAX4073H.

Set the full-scale output range by selecting R_{SENSE} and the appropriate gain version of the MAX4073.

Applications Information

Recommended Component Values

The MAX4073 senses a wide variety of currents with different sense resistor values. Table 1 lists common resistor values for typical operation of the MAX4073.

Choosing R_{SENSE}

To measure lower currents more accurately, use a large value for R_{SENSE}. The larger value develops a

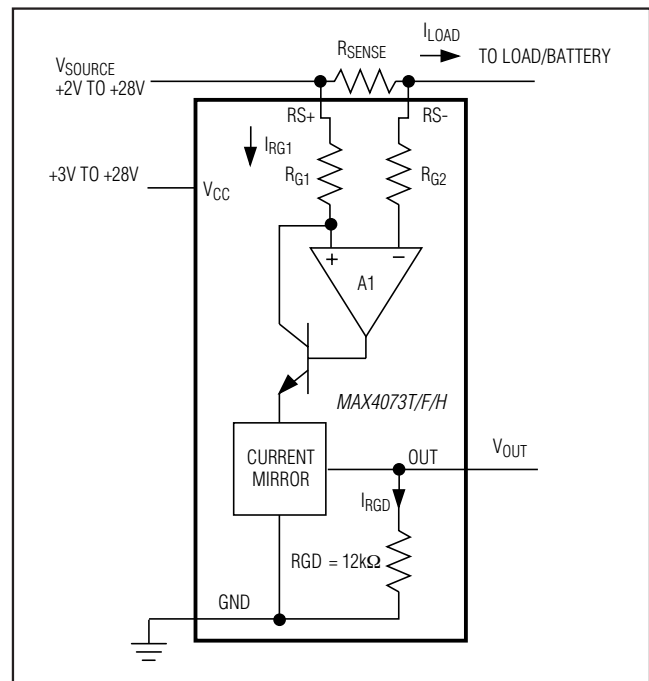

Figure 1. Functional Diagram

higher-sense voltage that reduces offset voltage errors of the internal op amp. Typical sense voltages range between 10mV and 150mV.

In applications monitoring very high currents, R_{SENSE} must be able to dissipate the I²R losses. If the resistor's rated power dissipation is exceeded, its value may drift or it may fail altogether, causing a differential voltage across the terminals in excess of the absolute maximum ratings (±5V).

If I_{SENSE} has a large high-frequency component, minimize the inductance of R_{SENSE}. Wire-wound resistors have the highest inductance, metal-film resistors are

MAX4073T/F/H

Low-Cost, SC70, Voltage-Output, High-Side Current-Sense Amplifier

somewhat better, and low-inductance metal-film resistors are best suited for these applications.

For $V_{SENSE} = 100\text{mV}$, full-scale output voltage can be 2V, 5V, or 10V depending on the gain. For proper operation, ensure V_{CC} exceeds the full-scale output voltage by 1.2V (see Output High Voltage ($V_{CC} - V_{OH}$) vs. Temperature in the *Typical Operating Characteristics*).

Using a PCB Trace as R_{SENSE}

If the cost of R_{SENSE} is an issue and accuracy is not critical, use the alternative solution shown in Figure 2. This solution uses copper PC board traces to create a sense resistor. The resistivity of a 0.1-inch-wide trace of 2-ounce copper is approximately $30\text{m}\Omega/\text{ft}$. The resistance-temperature coefficient of copper is fairly high (approximately $0.4\%/^{\circ}\text{C}$), so systems that experience a wide temperature variance must compensate for this effect. In addition, do not exceed the maximum power dissipation of the copper trace.

For example, the MAX4073T (with a maximum load current of 10A and an R_{SENSE} of $5\text{m}\Omega$) creates a full-scale V_{SENSE} of 50mV that yields a maximum V_{OUT} of 1V. R_{SENSE} in this case requires about 2 inches of 0.1 inch-wide copper trace.

Output Impedance

The output of the MAX4073 is a current source driving a $12\text{k}\Omega$ resistance. Resistive loading added to OUT reduces the output gain of the MAX4073. To minimize output errors for most applications, connect OUT to a high-impedance input stage. When output buffering is required, choose an op amp with a common-mode input range and an output voltage swing that includes ground when operating with a single supply. The op amp's supply voltage range should be at least as high as any voltage the system may encounter.

The percent error introduced by output loading is determined with the following formula:

$$\% \text{ERROR} = 100 \left(\frac{R_{LOAD}}{12\text{k}\Omega + R_{LOAD}} - 1 \right)$$

where R_{LOAD} is the external load applied to OUT.

Current Source Circuit

Figure 3 shows a block diagram using the MAX4073 with a switching regulator to make a current source.

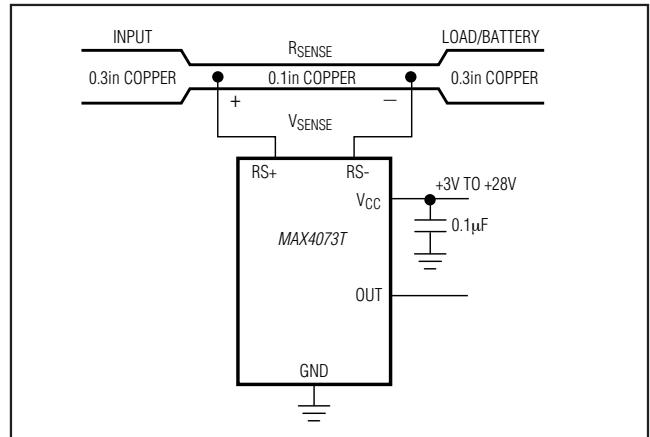

Figure 2. MAX4073T Connections Showing Use of PC Board

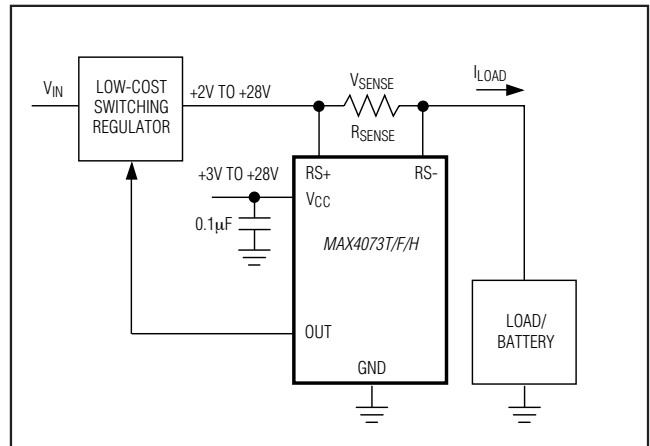

Figure 3. Current Source

MAX4073T/F/H

Low-Cost, SC70, Voltage-Output, High-Side Current-Sense Amplifier

Table 1. Recommended Component Values

FULL-SCALE LOAD CURRENT I_{LOAD} (A)	CURRENT-SENSE RESISTOR R_{SENSE} (m Ω)	GAIN	FULL-SCALE OUTPUT VOLTAGE (FULL-SCALE $V_{SENSE} = 100\text{mV}$) V_{OUT} (V)
0.1	1000	20	2.0
		50	5.0
		100	10.0
1	100	20	2.0
		50	5.0
		100	10.0
5	20	20	2.0
		50	5.0
		100	10.0
10	10	20	2.0
		50	5.0
		100	10.0

Pin Configurations

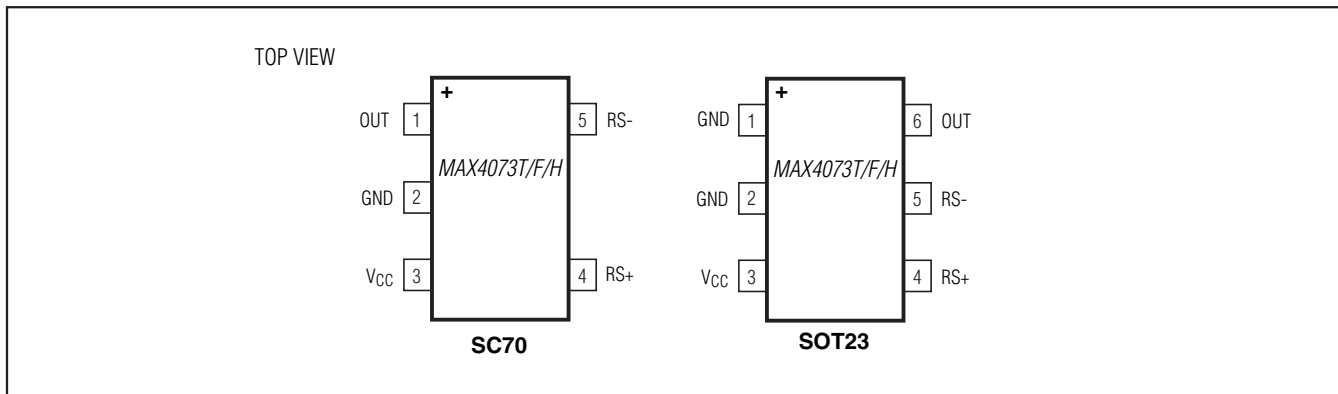

Chip Information

PROCESS: Bipolar

MAX4073T/F/H

Low-Cost, SC70, Voltage-Output, High-Side Current-Sense Amplifier

Package Information

For the latest package outline information and land patterns (footprints), go to www.maximintegrated.com/packages. Note that a "+", "#", or "-" in the package code indicates RoHS status only. Package drawings may show a different suffix character, but the drawing pertains to the package regardless of RoHS status.

PACKAGE TYPE	PACKAGE CODE	OUTLINE NO.	LAND PATTERN NO.
5 SC70	X5+1	21-0076	90-0188
6 SOT23	U6+4	21-0058	90-0175

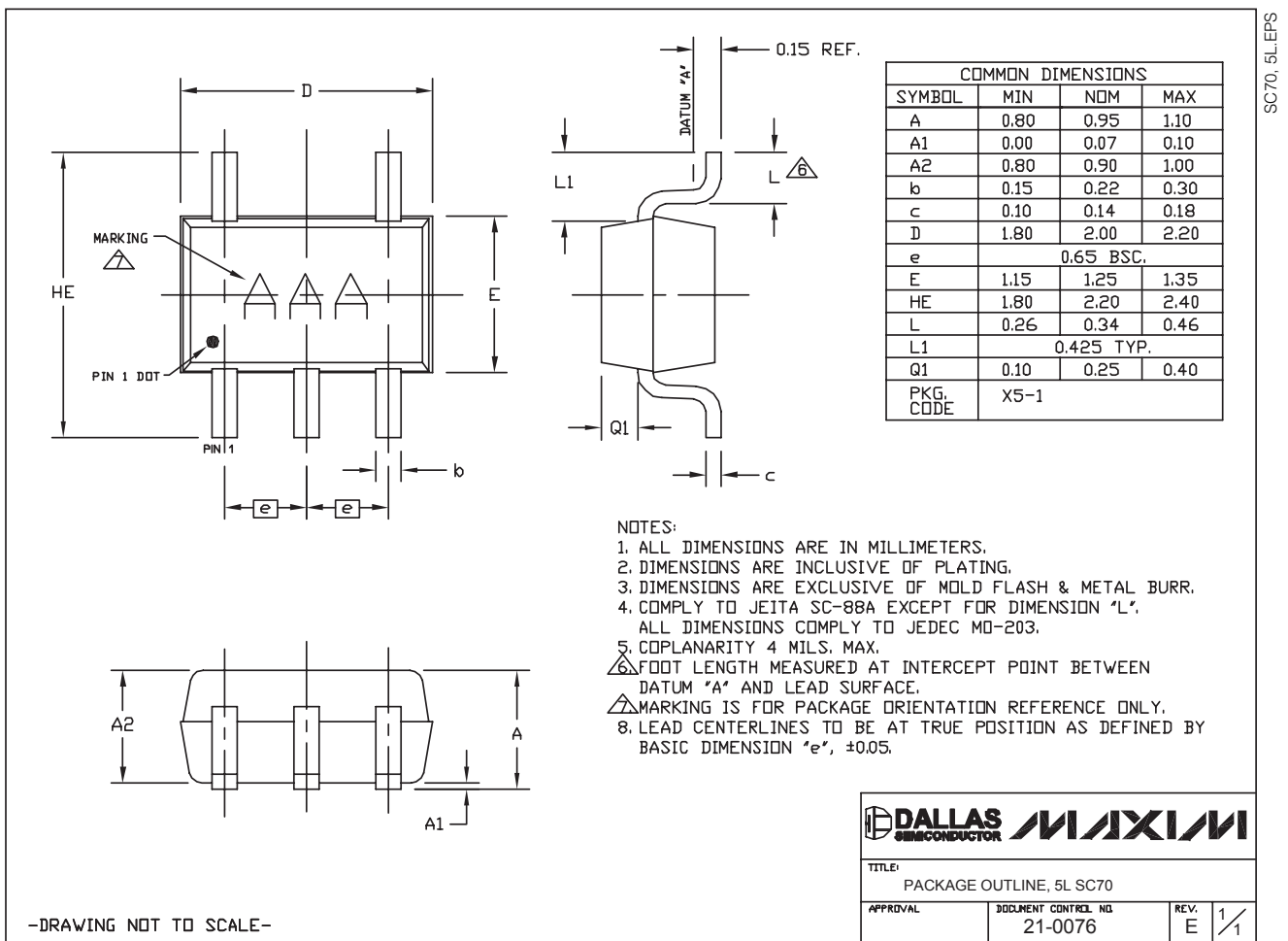

SC70, 5LEPS

MAX4073T/F/H

Low-Cost, SC70, Voltage-Output, High-Side Current-Sense Amplifier

Package Information (continued)

For the latest package outline information and land patterns (footprints), go to www.maximintegrated.com/packages. Note that a "+", "#", or "-" in the package code indicates RoHS status only. Package drawings may show a different suffix character, but the drawing pertains to the package regardless of RoHS status.

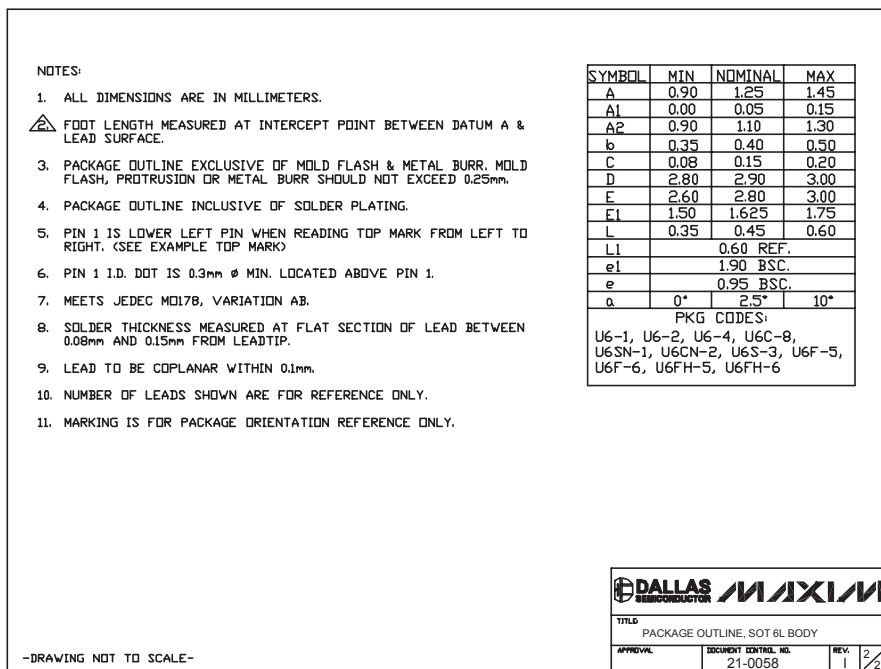
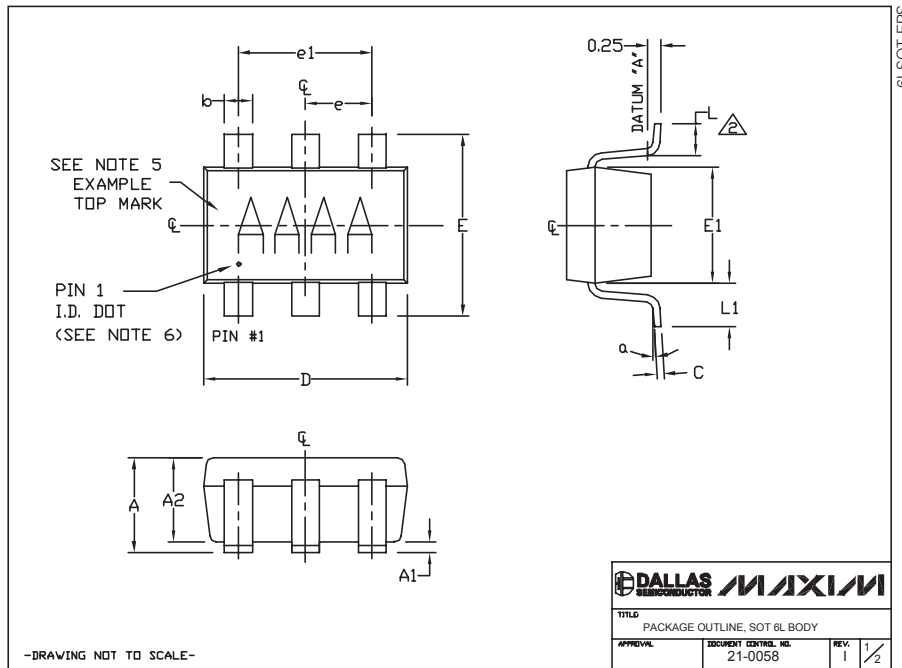

MAX4073T/F/H

Low-Cost, SC70, Voltage-Output, High-Side Current-Sense Amplifier

Revision History

REVISION NUMBER	REVISION DATE	DESCRIPTION	PAGES CHANGED
0	5/01	Initial release	—
2	8/12	Added lead-free notation to Ordering Information.	1



Maxim cannot assume responsibility for use of any circuitry other than circuitry entirely embodied in a Maxim product. No circuit patent licenses are implied. Maxim reserves the right to change the circuitry and specifications without notice at any time. The parametric values (min and max limits) shown in the Electrical Characteristics table are guaranteed. Other parametric values quoted in this data sheet are provided for guidance.

Looking for pricing, stock, or lifecycle information?

Click below to explore more details on WIN SOURCE:

 [View MAX4073FAUT on WIN SOURCE](#)

 [Maxim Integrated](#) Information

Optimize Your Supply Chain with WIN SOURCE Solutions

-  Global Sourcing Solution
-  Obsolete Management
-  Cost Control Management
-  Shortage Management
-  Alternative Solution
-  Excess Inventory Management