



**THE DATASHEET OF
MAX3668EHJ+T**





+3.3V, 622Mbps SDH/SONET Laser Driver with Automatic Power Control

MAX3668

General Description

The MAX3668 is a complete, +3.3V laser driver with automatic power control (APC) circuitry for SDH/SONET applications up to 622Mbps. It accepts differential PECL inputs, provides bias and modulation currents, and operates over a temperature range of -40°C to +85°C.

An APC feedback loop is incorporated to maintain a constant average optical power over temperature and lifetime. The wide modulation current range of 5mA to 75mA and bias current of 1mA to 80mA are easy to program, making this product ideal for use in various SDH/SONET applications.

The MAX3668 also provides enable control and a failure-monitor output to indicate when the APC loop is unable to maintain the average optical power. The MAX3668 is available in a 5mm 32-pin TQFP package as well as in dice.

Applications

- 622Mbps SDH/SONET Access Nodes
- Laser Driver Transmitters
- Section Regenerators

Features

- ◆ Single +3.3V or +5.0V Operation
- ◆ 38mA Supply Current at +3.3V
- ◆ Programmable Modulation Current from 5mA to 75mA
- ◆ Programmable Bias Current from 1mA to 80mA
- ◆ Rise/Fall Time <200ps
- ◆ Automatic Average Power Control with Failure Monitor
- ◆ Complies with ANSI, ITU, and Bellcore SONET/SDH Specifications
- ◆ Enable Control

Ordering Information

| PART | TEMP RANGE | PIN-PACKAGE |
|-------------|----------------|---------------------|
| MAX3668EHJ | -40°C to +85°C | 32 TQFP (5mm x 5mm) |
| MAX3668EHJ+ | -40°C to +85°C | 32 TQFP (5mm x 5mm) |
| MAX3668E/D | Note | Dice* |

Note: Dice are designed to operate over a -40°C to +140°C junction temperature (T_j) range, but are tested and guaranteed at $T_A = +25^\circ\text{C}$.

*Contact factory for availability.

+Denotes lead-free package.

Pin Configuration appears at end of data sheet.

Typical Operating Circuit

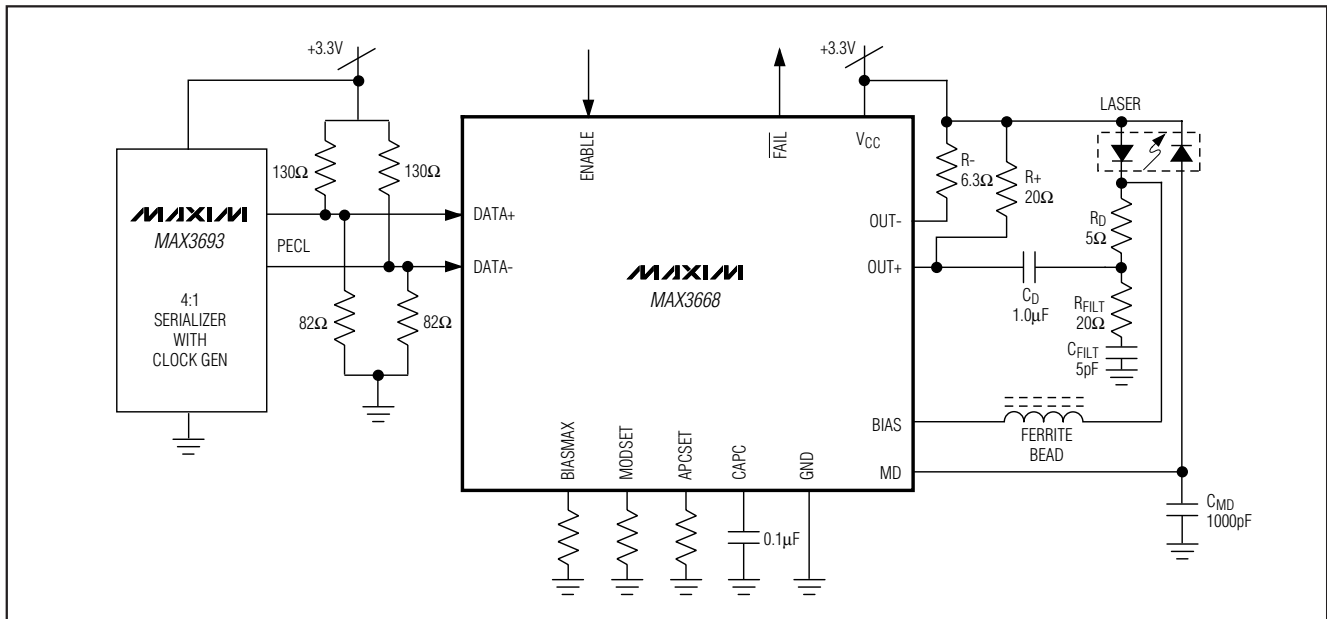

+3.3V, 622Mbps SDH/SONET Laser Driver with Automatic Power Control

ABSOLUTE MAXIMUM RATINGS

| | | | |
|--|-----------------------------------|---|-----------------------------------|
| Supply Voltage, V _{CC} | -0.5V to +7.0V | Voltage at BIAS | +1.0V to (V _{CC} + 0.5V) |
| Current into BIAS | -20mA to +150mA | Continuous Power Dissipation (T _A = +85°C) | |
| Current into OUT+, OUT- | -20mA to +100mA | 32-Pin TQFP (derate 14.3mW/°C above +85°C)..... | 929mW |
| Current into MD..... | -5mA to +5mA | Operating Junction Temperature Range..... | -55°C to +150°C |
| Voltage at DATA+, DATA-, ENABLE, FAIL | -0.5V to (V _{CC} + 0.5V) | Processing Temperature (Die)..... | +400°C |
| Voltage at OUT+, OUT-..... | +1.5V to (V _{CC} + 1.5V) | Storage Temperature Range | -65°C to +165°C |
| Voltage at MODSET, APCSET, BIASMAX, CAPC..... | -0.5V to +3.0V | Lead Temperature (soldering, 10s) | +300°C |

Stresses beyond those listed under "Absolute Maximum Ratings" may cause permanent damage to the device. These are stress ratings only, and functional operation of the device at these or any other conditions beyond those indicated in the operational sections of the specifications is not implied. Exposure to absolute maximum rating conditions for extended periods may affect device reliability.

DC ELECTRICAL CHARACTERISTICS

(V_{CC} = +3.14V to +5.5V, T_A = -40°C to +85°C, unless otherwise noted. Typical values are at V_{CC} = +3.3V, T_A = +25°C.) (Note 1)

| PARAMETER | SYMBOL | CONDITIONS | | MIN | TYP | MAX | UNITS |
|---|-------------------|--|---------------------------------|------------------------|------------------------|--------------------------------------|--------|
| Supply Current | | (Note 2) | | | 38 | 60 | mA |
| Bias Current Range | I _{BIAS} | V _{BIAS} = V _{CC} - 1.6V | | 1 | | 80 | mA |
| Bias Off Current | | ENABLE = low (Note 3) | | | | 100 | μA |
| Bias Current Stability | | APC open loop | I _{BIAS} = 80mA | | 390 | | ppm/°C |
| | | | I _{BIAS} = 1mA | | 920 | | |
| Bias Current Absolute Accuracy | | APC open loop | | -15 | | 15 | % |
| Differential Input Voltage | V _{ID} | Figure 1 | | 200 | | 1600 | mVp-p |
| Common-Mode Input Voltage | V _{ICM} | PECL compatible | | V _{CC} - 1.49 | V _{CC} - 1.32 | V _{CC} - V _{ID} /4 | V |
| DATA+, DATA- Input Current | I _{IN} | | | -1 | | 10 | μA |
| Monitor Diode Current Stability | | (Note 4) | I _{MD} = 1mA | -480 | 10 | 480 | ppm/°C |
| | | | I _{MD} = 18μA (Note 5) | | 70 | | |
| Monitor Diode Current Absolute Accuracy | | | | -15 | | 15 | % |
| DC Monitor Diode Current | I _{MD} | | | 18 | | 1000 | μA |
| Monitor Diode Input Voltage (MD Pin) | V _{MD} | | | | 0.8 | | V |
| TTL Input High Voltage | V _{IH} | | | 2.0 | | | V |
| TTL Input Low Voltage | V _{IL} | | | | | 0.8 | V |
| TTL Output High Voltage (FAIL) | V _{OH} | Sourcing 50μA | | 2.4 | V _{CC} - 0.3 | V _{CC} | V |
| TTL Output Low Voltage (FAIL) | V _{OL} | Sinking 100μA | | 0.1 | | 0.44 | V |

+3.3V, 622Mbps SDH/SONET Laser Driver with Automatic Power Control

MAX3668

AC ELECTRICAL CHARACTERISTICS

(V_{CC} = +3.14V to +5.5V, load as shown in Figure 2, T_A = -40°C to +85°C, unless otherwise noted. Typical values are at V_{CC} = +3.3V, T_A = +25°C.) (Note 6)

| PARAMETER | SYMBOL | CONDITIONS | MIN | TYP | MAX | UNITS |
|---|--------------------------------|---|-------------------------|-----|-----|--------|
| Modulation Current Range | I _{MOD} | (Note 7) | 5 | | 75 | mA |
| Modulation Off Current | | ENABLE = low (Note 3) | | | 200 | μA |
| Modulation Current Stability | | I _{MOD} = 75mA | -620 | 175 | 620 | ppm/°C |
| | | I _{MOD} = 5mA (Note 5) | | 300 | | |
| Modulation Current Absolute Accuracy | | | -15 | | 15 | % |
| Output Rise/Fall Time | t _R /t _F | 20% to 80%, R _L = 10Ω 20Ω load | I _{MOD} = 5mA | 100 | 200 | ps |
| | | | I _{MOD} = 75mA | 230 | 375 | |
| Jitter Generation (peak-to-peak) | | (Note 8) | | | 100 | ps |
| Pulse-Width Distortion (peak-to-peak) | | (Notes 9, 10) | I _{MOD} = 5mA | 70 | 155 | ps |
| | | | I _{MOD} = 75mA | 10 | 135 | |
| Enable/Start-Up Delay | | Open loop | | 250 | | ns |
| Maximum Consecutive Identical Digits at 622Mbps | CID | | 80 | | | Bits |

Note 1: Characteristics at -40°C are guaranteed by design and characterization. Dice are tested at T_A = +25°C only.

Note 2: Tested with R_{MODSET} = 5.11kΩ (I_{MOD} ≈ 38mA), R_{BIASMAX} = 4.56kΩ (I_{BIAS} ≈ 52mA), excluding I_{BIAS} and I_{MOD}.

Note 3: Both the bias and modulation currents will be disabled if any of the current set pins are shorted to ground.

Note 4: This assumes that the laser to monitor diode transfer function does not change with temperature.

Note 5: See *Typical Operating Characteristics* for worst-case distributions.

Note 6: AC characteristics are guaranteed by design and characterization.

Note 7: Total I_{MOD} out of OUT+. Refer to the *Design Procedure* for information regarding current delivered to the laser.

Note 8: Input signal is a 622Mbps, 2¹³-1 PRBS with 80 inserted zeros.

Note 9: Input signal is a 622Mbps, 11110000 pattern.

Note 10: PWD = (wider pulse – narrower pulse) / 2.

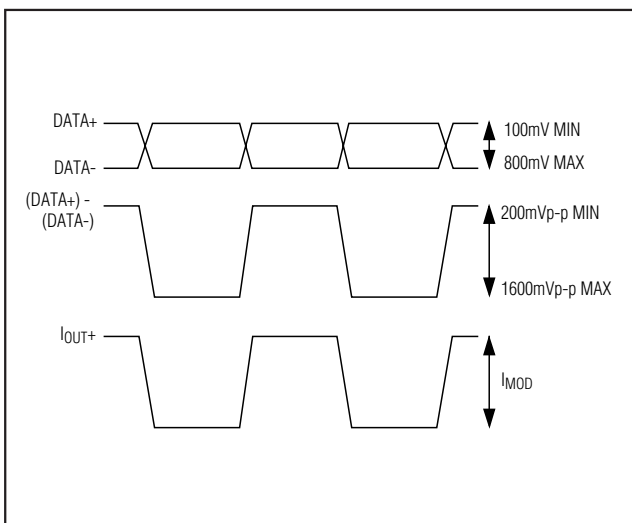

Figure 1. Required Input Signal and Output Polarity

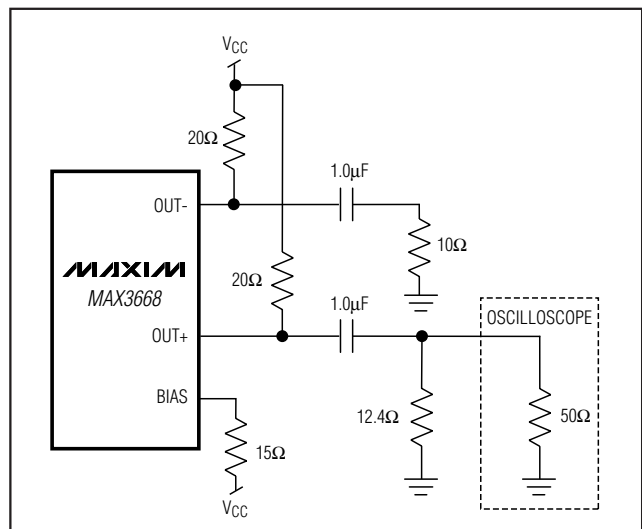

Figure 2. Output Termination for Characterization

+3.3V, 622Mbps SDH/SONET Laser Driver with Automatic Power Control

Typical Operating Characteristics

($V_{CC} = +3.3V$, $T_A = +25^\circ C$, unless otherwise noted.)

EYE DIAGRAM
(622Mbps, 1300nm LASER
WITH 467MHz FILTER)

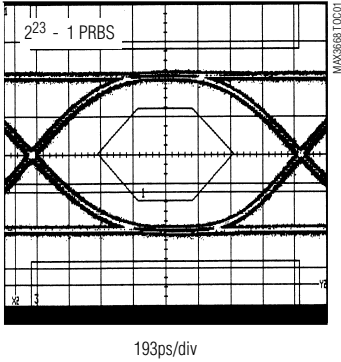

EYE DIAGRAM
($I_{MOD} = 35mA$)

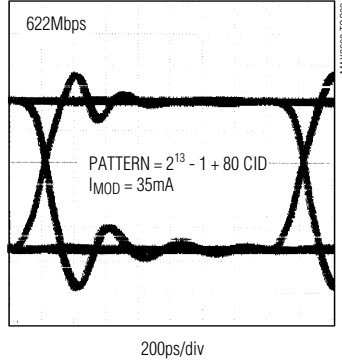

EYE DIAGRAM
($I_{MOD} = 75mA$)

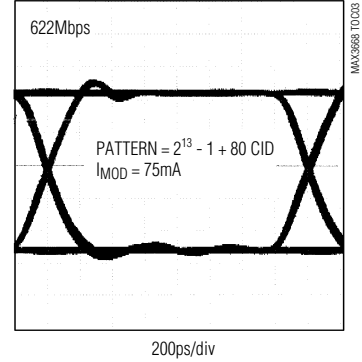

MONITOR DIODE CURRENT
vs. APC SET RESISTOR

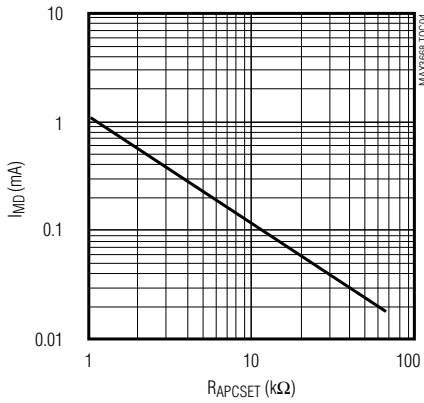

BIAS CURRENT vs.
MAXIMUM BIAS SET RESISTOR

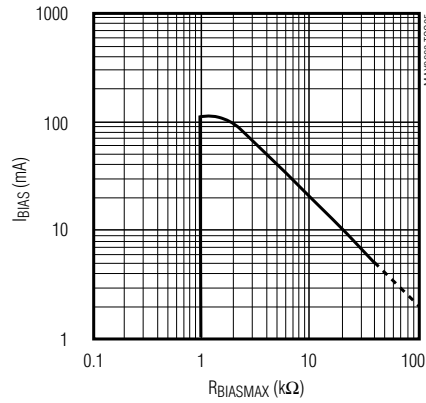

MODULATION CURRENT
vs. MODULATION SET RESISTOR

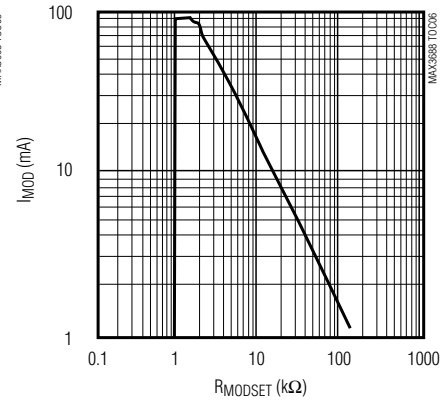

RANDOM JITTER
vs. MODULATION CURRENT

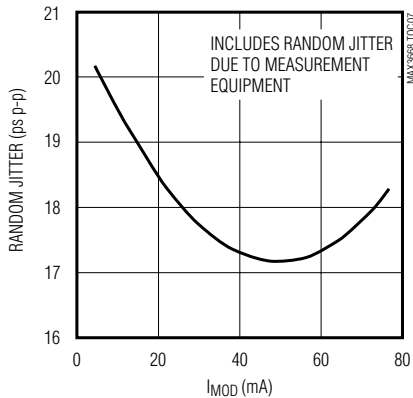

PULSE-WIDTH DISTORTION
vs. MODULATION CURRENT

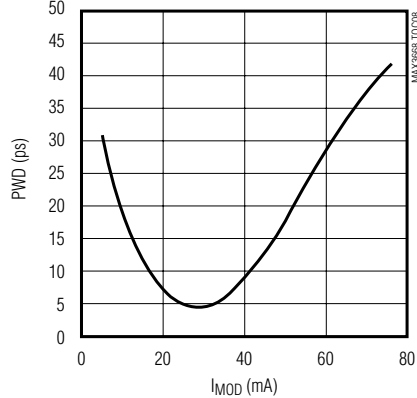

SUPPLY CURRENT
vs. TEMPERATURE

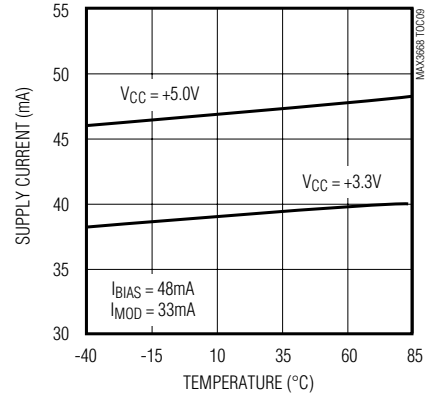

+3.3V, 622Mbps SDH/SONET Laser Driver with Automatic Power Control

Typical Operating Characteristics (continued)

($V_{CC} = +3.3V$, $T_A = +25^\circ C$, unless otherwise noted.)

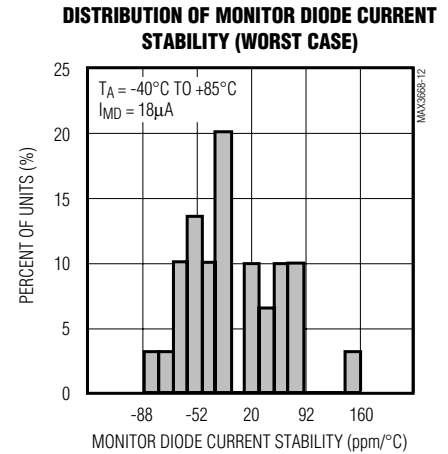
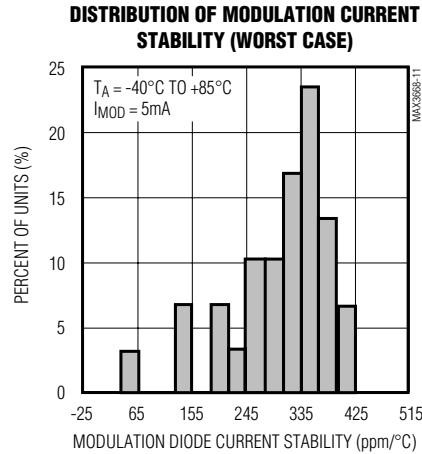
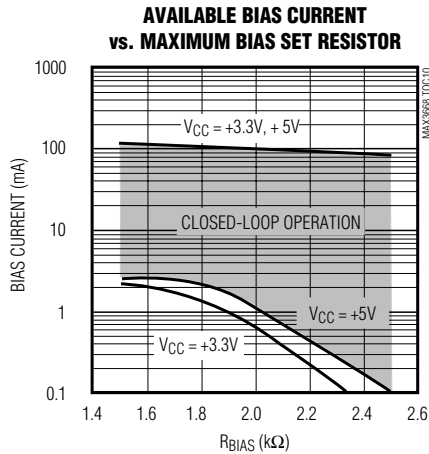

Pin Description

| PIN | NAME | FUNCTION |
|-----------------------------|-------------------|---|
| 1, 2, 6, 15, 17, 20, 24 | V_{CC} | Positive Supply Voltage |
| 3 | DATA+ | Positive PECL Data Input |
| 4 | DATA- | Negative PECL Data Input |
| 5, 7, 8, 10, 14, 21, 22, 30 | GND | Ground |
| 9 | ENABLE | TTL/CMOS Enable Input. High for normal operation, low to disable laser bias and modulation currents. Internally pulled high. |
| 11 | \overline{FAIL} | TTL Output. Indicates APC failure when low. Internally pulled high through a 6k Ω resistor. |
| 12, 13, 26, 27, 28 | N.C. | No Connection. Leave unconnected. |
| 16 | BIAS | Laser Bias Current Output. Isolate from laser with a ferrite bead. |
| 18 | OUT+ | Positive Modulation Current Output. I_{MOD} flows into this pad when the input signal is high. Connect this pad to AC coupling network. |
| 19 | OUT- | Negative Modulation Current Output. I_{MOD} flows into this pad when the input signal is low. Connect this pad to V_{CC} through a 6.3 Ω resistor. |
| 23 | MD | Monitor Photodiode Connection. Connect this pad to the monitor photodiode anode. A capacitor to ground is required to filter high-speed AC monitor photocurrent. |
| 25 | CAPC | APC Compensation Capacitor. A 0.1 μF capacitor connected from this pad to ground controls the dominant pole of the automatic power control (APC) feedback loop. |
| 29 | APCSET | APC Set Resistor. A resistor connected from this pad to ground sets the desired average optical power. The resulting current is equal to the desired DC monitor diode current. Connect a 100k Ω resistor from this pad to ground if APC is not used. |
| 31 | MODSET | Modulation Set Resistor. A resistor from this pad to ground sets the laser modulation current. |
| 32 | BIASMAX | Maximum Bias Set Resistor. A resistor from this pad to ground sets the maximum laser bias current. The APC function can subtract from this maximum value but cannot add to it. This resistor controls the bias-current level when the APC loop is not used. |

+3.3V, 622Mbps SDH/SONET Laser Driver with Automatic Power Control

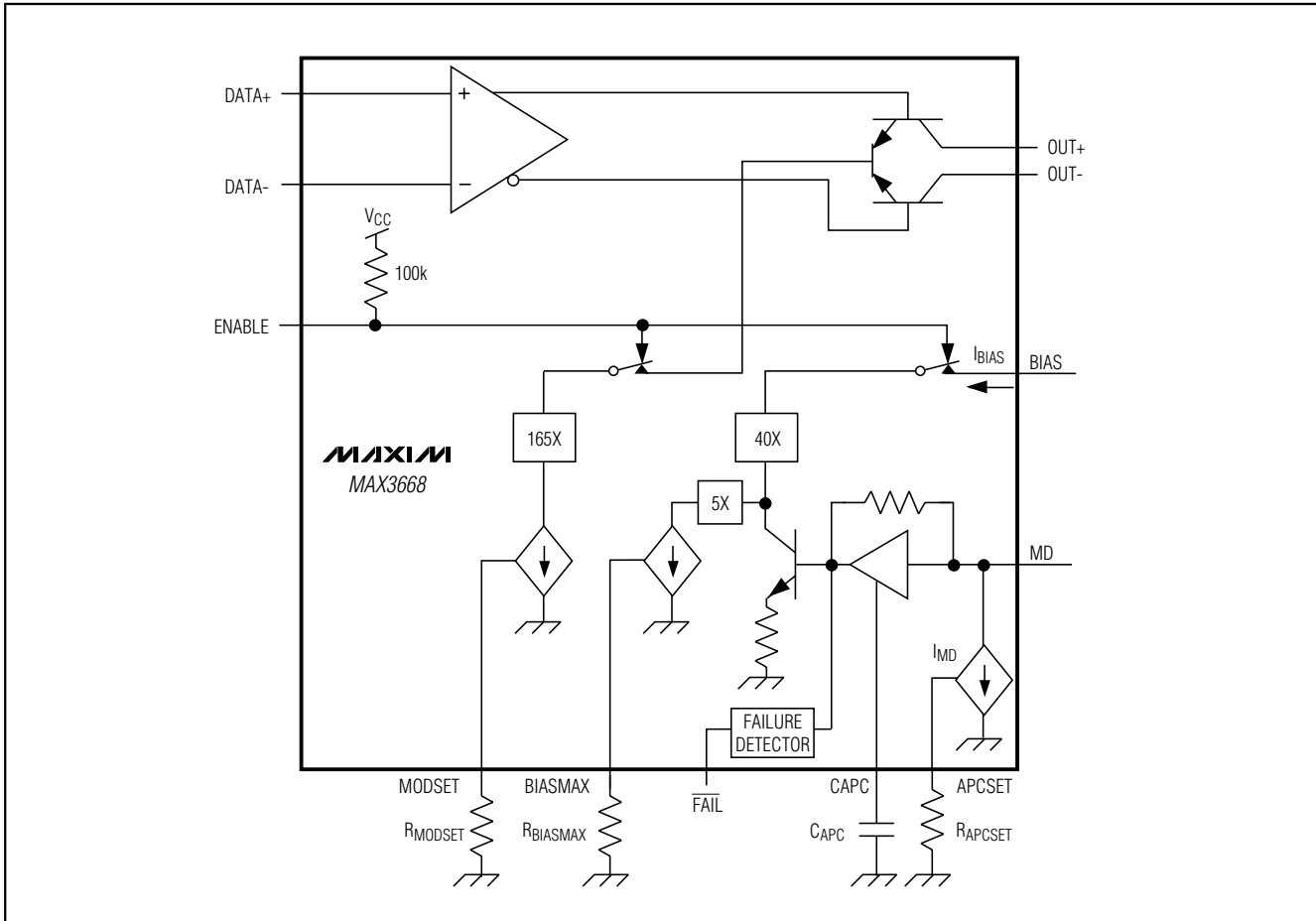

Figure 3. Functional Diagram

Detailed Description

The MAX3668 laser driver consists of two main parts: a high-speed modulation driver and a laser-biasing block with Automatic Power Control (APC). The circuit is optimized for low-voltage (+3.3V) operation.

The output stage is composed of a high-speed differential pair and a programmable modulation current source. Since the modulation output drives a maximum current of 75mA into the laser with a 230ps edge speed, large transient voltage spikes can be generated due to the parasitic inductance. These transients and the laser forward voltage leave insufficient headroom for the proper operation of the laser driver if the modulation output is DC-coupled to the laser diode. To solve this problem, the MAX3668's modulation output is designed to be

AC-coupled to the cathode of a laser diode. A simplified functional diagram is shown in Figure 3.

The MAX3668 modulation output is optimized for driving a $20\Omega \parallel 10\Omega$ load; the minimum required voltage at OUT+ is 2.0V. Modulation current swings of 75mA are possible. To interface with the laser diode, a damping resistor (R_D) is required for impedance matching. An RC shunt network may be used to compensate for the laser-diode parasitic inductance, thereby improving the optical output aberrations and duty-cycle distortion.

At a 622Mbps data rate, any capacitive load at the cathode of a laser diode degrades the optical output performance. Since the BIAS output is directly connected to the laser cathode, minimize the parasitic capacitance associated with this pin by using an inductor to isolate the BIAS pin from the laser cathode.

+3.3V, 622Mbps SDH/SONET Laser Driver with Automatic Power Control

Automatic Power Control

To maintain constant average optical power, the MAX3668 incorporates an APC loop to compensate for the changes in laser threshold current over temperature and lifetime. A back-facet photodiode mounted in the laser package is used to convert the optical power into a photocurrent. The APC loop adjusts the laser bias current so the monitor current is matched to a reference current set by R_{APCSET}. The time constant of the APC loop is determined by an external capacitor (C_{APC}). To eliminate the pattern-dependent jitter associated with the APC loop-time constant and to guarantee loop stability, the recommended value for C_{APC} is 0.1μF.

When the APC loop is functioning, the maximum allowable bias current is set by an external resistor, R_{BIASMAX}. An APC failure flag ($\overline{\text{FAIL}}$) is set low when the bias current can no longer be adjusted to achieve the desired average optical power.

APC closed-loop operation requires the user to set three currents with external resistors connected between ground and BIASMAX, MODSET, and APCSET. Detailed guidelines for these resistor settings are described in the *Design Procedure* section.

Open-Loop Operation

If necessary, the MAX3668 is fully operational without APC. In this case, the laser current is directly set by two external resistors connected from ground to BIASMAX and MODSET. Connect a 100kΩ resistor from APCSET to ground and leave MD open for open-loop operation.

Enable Control

The MAX3668 incorporates a laser driver enable function. When ENABLE is low, both the bias and modulation currents are off. The typical laser enable time is 250ns.

APC Failure Monitor

The MAX3668 provides an APC failure monitor (TTL/CMOS) to indicate an APC loop tracking failure. $\overline{\text{FAIL}}$ is set low when the APC loop can no longer adjust the bias current to maintain the desired monitor current. This output is internally pulled up to V_{CC} through a 6kΩ resistor.

Table 1. Optical Power Definition

| PARAMETER | SYMBOL | RELATION |
|------------------------|------------------|--|
| Average Power | P _{AVE} | $P_{AVE} = (P_0 + P_1) / 2$ |
| Extinction Ratio | r _e | $r_e = P_1 / P_0$ |
| Optical Power High | P ₁ | $P_1 = 2P_{AVE} \cdot r_e / (r_e + 1)$ |
| Optical Power Low | P ₀ | $P_0 = 2P_{AVE} / (r_e + 1)$ |
| Optical Amplitude | P _{p-p} | $P_{p-p} = 2P_{AVE} (r_e - 1) / (r_e + 1)$ |
| Laser Slope Efficiency | η | $\eta = P_{p-p} / I_{MOD}$ |
| Modulation Current | I _{MOD} | $I_{MOD} = P_{p-p} / \eta$ |

Short-Circuit Protection

The MAX3668 provides short-circuit protection for the modulation, bias, and monitor current sources. If either BIASMAX, MODSET, or APCSET is shorted to ground, the bias and modulation outputs will be turned off.

Design Procedure

When designing a laser transmitter, the optical output is usually expressed in terms of average power and extinction ratio. Table 1 gives the relationships that are helpful in converting between the optical average power and the modulation current. These relationships are valid if the average duty cycle of the optical waveform is 50%.

Programming the Modulation Current

In addition to being a function of R_{MODSET}, the modulation current delivered to the laser (I_{MODL}) also depends on the values of the series damping resistor (R_D), the shunt compensation resistance (R_{FILT}), and the laser diode's resistance (see *Typical Operating Circuit*).

The modulation current (assuming C_{FILT} << C_D) into the laser diode can be represented by the following:

$$I_{MODL} = I_{MOD} \left[\frac{20\Omega}{20\Omega + (R_D + r_{LASER})} \right]$$

Assuming R_D = 5Ω and r_{LASER} = 5Ω, this equation is simplified to:

$$I_{MODL} = I_{MOD}(0.67)$$

For R_D = 5.0Ω and a laser resistance of approximately 5Ω, refer to the Modulation Current vs. Modulation Set Resistor graph in the *Typical Operating Characteristics* and select the value of R_{MODSET} that corresponds to the required current at +25°C.

Programming the Bias Current

When using the MAX3668 in open-loop operation, the bias current is determined by the R_{BIASMAX} resistor. To select this resistor, determine the required bias current at +25°C. Refer to the Bias Current vs. Maximum Bias Set Resistor graph in the *Typical Operating Characteristics* and select the value of R_{BIASMAX} that corresponds to the required current at +25°C.

When using the MAX3668 in closed-loop operation, the R_{BIASMAX} resistor sets the maximum bias current available to the laser diode over temperature and life. The APC loop can subtract from this maximum value but cannot add to it. Refer to the Bias Current vs. Maximum Bias Set Resistor graph in the *Typical Operating Characteristics* and select the value of R_{BIASMAX} that corresponds to the end-of-life bias current at +85°C.

+3.3V, 622Mbps SDH/SONET Laser Driver with Automatic Power Control

Programming the APC Loop

When the MAX3668's APC feature is used, program the average optical power by adjusting the APCSET resistor. To select this resistor, determine the desired monitor current to be maintained over temperature and life. Refer to the Monitor Diode Current vs. APC Set Resistor graph in the *Typical Operating Characteristics* and select the value of R_{APCSET} that corresponds to the required current.

Interfacing with the Laser Diode

To minimize optical output aberrations due to the laser parasitic inductance, an RC shunt network may be used (see *Typical Operating Circuit*). If R_L represents the laser diode resistance, the recommended total resistance for $R_D + R_L$ is 10Ω . Starting values for coaxial lasers are $R_{FILT} = 20\Omega$ and $C_{FILT} = 5pF$. R_{FILT} and C_{FILT} should be experimentally adjusted to optimize the output waveform. A bypass capacitor should also be placed as close to the laser anode as possible for best performance.

Pattern-Dependent Jitter (PDJ)

When transmitting NRZ data with long strings of consecutive identical digits (CID), LF droop can contribute to pattern-dependent jitter. To minimize this pattern-dependent jitter, two external components must be properly chosen: capacitor C_{APC} , which dominates the APC loop time constant; and AC-coupling capacitor C_D .

To filter out noise effects and guarantee loop stability, the recommended value for C_{APC} is $0.1\mu F$. This results in an APC loop bandwidth of 20kHz. Consequently, the pattern-dependent jitter associated with an APC loop time constant can be ignored.

The time constant associated with the DC blocking capacitor on I_{MOD} will have an effect on PDJ. It is important that this time constant produce minimum droop for long consecutive bit streams.

Referring to Figure 4, the droop resulting from long time periods without transitions can be represented by the following equation:

$$(100\% - \text{DROOP}) = e^{-\frac{t}{\tau}}$$

AC coupling of I_{MOD} results in a discharge level for τ that is equal to P_{AVG} . An overall droop of 6% relative to P_{p-p} equates to a 12% droop relative to P_{AVG} . To ensure a droop of less than 12% (6% relative to P_{p-p}), this equation can be solved for τ as follows:

$$\tau = \frac{-t}{\ln(1 - 0.12)} = 7.8t$$

If t_1 equals 80 consecutive unit intervals without a transition, the time constant associated with the DC blocking capacitor needs to be longer than:

$$\tau_{AC} \geq R_{AC}C_D = 7.8 (80 \text{ bits}) (1.6\text{ns/bit}) = 1.0\mu s$$

R_{FILT} can be ignored for $C_{FILT} \ll C_D$, therefore the estimated value of R_{AC} is:

$$R_{AC} = 20\Omega \parallel (R_D + r_{LASER})$$

Assuming $R_D = 5\Omega$, and $r_{LASER} = 5\Omega$:

$$R_{AC} = 6.7\Omega$$

with $C_D = 1.0\mu F$, $\tau_{AC} = 6.7\mu s$.

Input Termination Requirement

The MAX3668 data inputs are PECL-compatible. However, it is not necessary to drive the MAX3668 with a standard PECL signal. As long as the specified common-mode voltage and differential voltage swings are met, the MAX3668 will operate properly.

Calculate Power Consumption

The total power dissipation of the MAX3668 can be estimated by the following:

$$P = V_{CC} \times I_{CC} + (V_{CC} - V_f) \times I_{BIAS} + I_{MOD} (V_{CC} - 20\Omega \times I_{MOD} / 2)$$

where I_{BIAS} is the maximum bias current set by $R_{BIAS-MAX}$, I_{MOD} is the modulation current, and V_f is the typical laser forward voltage.

Applications Information

The following is an example of how to set up the MAX3668.

Select Laser

A communication-grade laser should be selected for 622Mbps applications. Assume the laser output average power is $P_{AVE} = 0\text{dBm}$, the minimum extinction

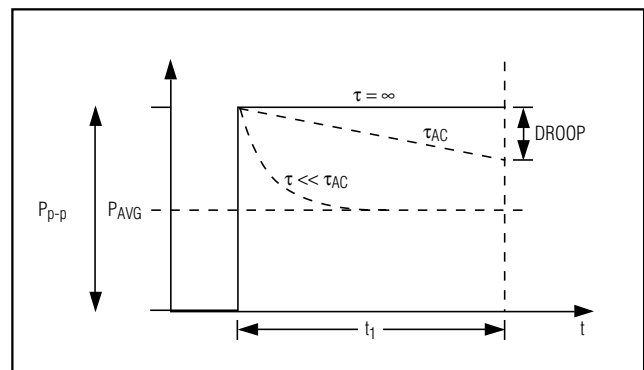

Figure 4. Droop

+3.3V, 622Mbps SDH/SONET Laser Driver with Automatic Power Control

ratio is $r_e = 6.6$ (8.2dB), the operating temperature is -40°C to $+85^{\circ}\text{C}$, and the laser diode has the following characteristics:

| | |
|------------------------------------|--|
| Wavelength: | $\lambda = 1.3\mu\text{m}$ |
| Threshold Current: | $I_{\text{TH}} = 22\text{mA}$ at $+25^{\circ}\text{C}$ |
| Threshold Temperature Coefficient: | $\beta_{\text{TH}} = 1.3\%/^{\circ}\text{C}$ |
| Laser to Monitor Transfer: | $\rho_{\text{MON}} = 0.2\text{A/W}$ |
| Laser Slope Efficiency: | $\eta = 0.05\text{mW/mA}$ at $+25^{\circ}\text{C}$ |

Determine R_{APCSET}

The desired monitor diode current is estimated by $I_{\text{MD}} = P_{\text{AVE}} \times \rho_{\text{MON}} = 200\mu\text{A}$. The Monitor Diode Current vs. APC Set Resistor graph in the *Typical Operating Characteristics* shows that R_{APCSET} should be $6\text{k}\Omega$.

Determine R_{MODSET}

To achieve a minimum extinction ratio (r_e) of 6.6 over temperature and lifetime, calculate the required extinction ratio at $+25^{\circ}\text{C}$. Assuming $r_e = 20$, the peak-to-peak optical power $P_{\text{p-p}} = 1.81\text{mW}$ according to Table 1. The required modulation current is $1.81(\text{mW}) / 0.05(\text{mW/mA}) = 36.2\text{mA}$. The Modulation Current vs. Modulation Set Resistor graph in the (*see Typical Operating Characteristics*) shows that R_{MODSET} should be $5\text{k}\Omega$.

Determine R_{BIASMAX}

Calculate the maximum threshold current ($I_{\text{TH}}(\text{MAX})$) at $T_A = +85^{\circ}\text{C}$ and end of life. Assuming $I_{\text{TH}}(\text{MAX}) = 50\text{mA}$, the maximum bias current should be:

$$I_{\text{BIAS}} = I_{\text{TH}}(\text{MAX}) + I_{\text{MOD}} / 2$$

In this example, $I_{\text{BIAS}} = 68.1\text{mA}$. The Bias Current vs. Maximum Bias Set Resistor graph in the *Typical Operating Characteristics* shows that R_{BIASMAX} should be $3\text{k}\Omega$.

Modulation Current More than 50mA

To drive modulation currents greater than 50mA at 3.3V, external pull-up inductors (Figure 5) should be used to DC-bias the modulation output at V_{CC} . Such a configuration isolates the laser forward voltage from the output circuitry and allows the output at OUT+ to swing above and below the supply voltage V_{CC} .

At $+5\text{V}$ power supply, the headroom voltage for the MAX3668 is significantly improved. In this case, it is possible to achieve a modulation current of more than 50mA (using resistor pull-ups as shown in the *Typical Operating Circuit*). The MAX3668 can also be DC-coupled to a laser diode when operating at $+5\text{V}$ supply; the voltage at OUT+ should be $\geq 2.0\text{V}$ for proper operation.

Wire Bonding Die

For high current density and reliable operation, the MAX3668 uses gold metalization. Make connections to the die with gold wire only, using ball-bonding techniques. Wedge bonding is not recommended. Die-pad size is 4 mils ($100\mu\text{m}$) square, and die thickness is 12 mils ($300\mu\text{m}$) mils.

Layout Considerations

To minimize inductance, keep the connections between the MAX3668 output pins and LD as close as possible. Optimize the laser diode performance by placing a bypass capacitor as close as possible to the laser anode. Use good high-frequency layout techniques and multilayer boards with uninterrupted ground planes to minimize EMI and crosstalk.

Laser Safety and IEC 825

Using the MAX3668 laser driver alone does not ensure that a transmitter design is compliant with IEC 825. The entire transmitter circuit and component selections must be considered. Customers must determine the level of fault tolerance required by their application, recognizing that Maxim products are not designed or authorized for use as components in systems intended for surgical implant into the body, for applications intended to support or sustain life, or for any other application where the failure of a Maxim product could create a situation where personal injury or death may occur.

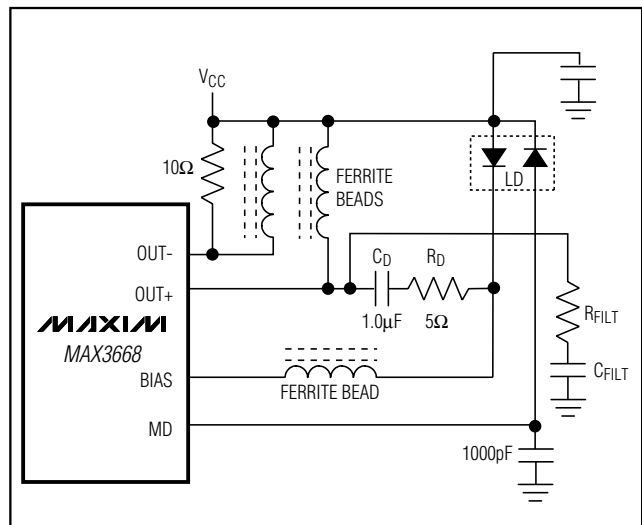
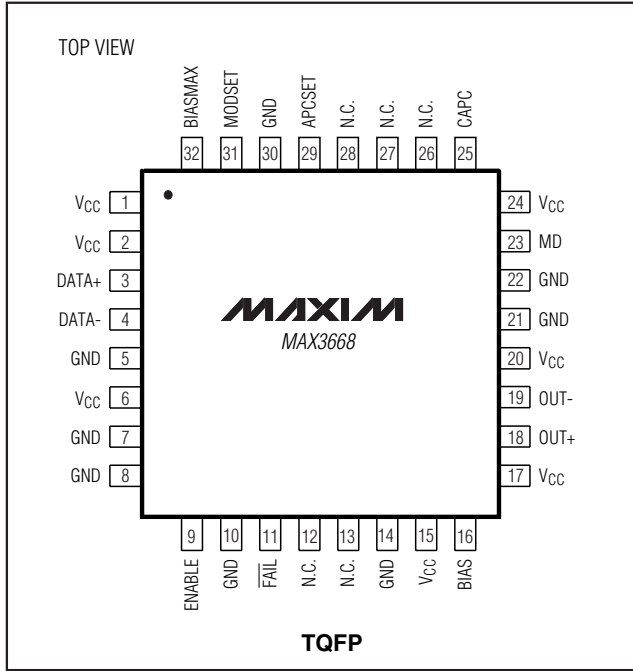

Figure 5. Output Termination for Maximum Modulation Current

+3.3V, 622Mbps SDH/SONET Laser Driver with Automatic Power Control

Pin Configuration



Chip Topography

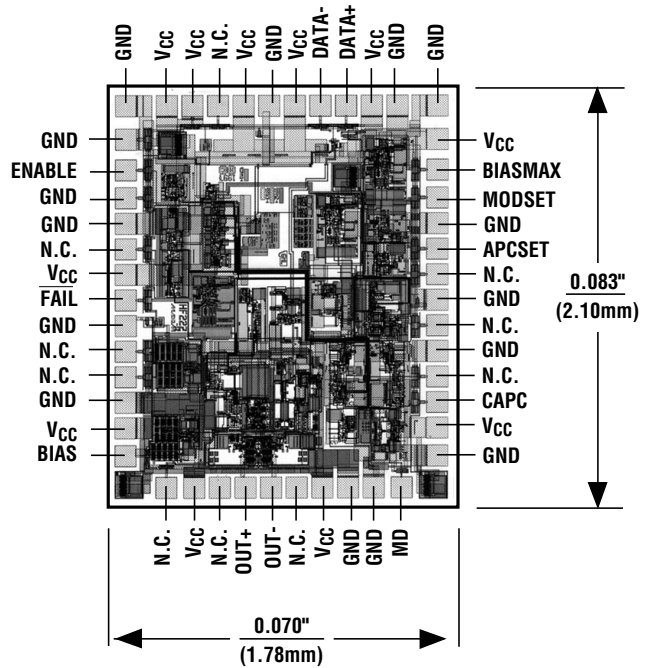

+3.3V, 622Mbps SDH/SONET Laser Driver with Automatic Power Control

Package Information

MAX3668

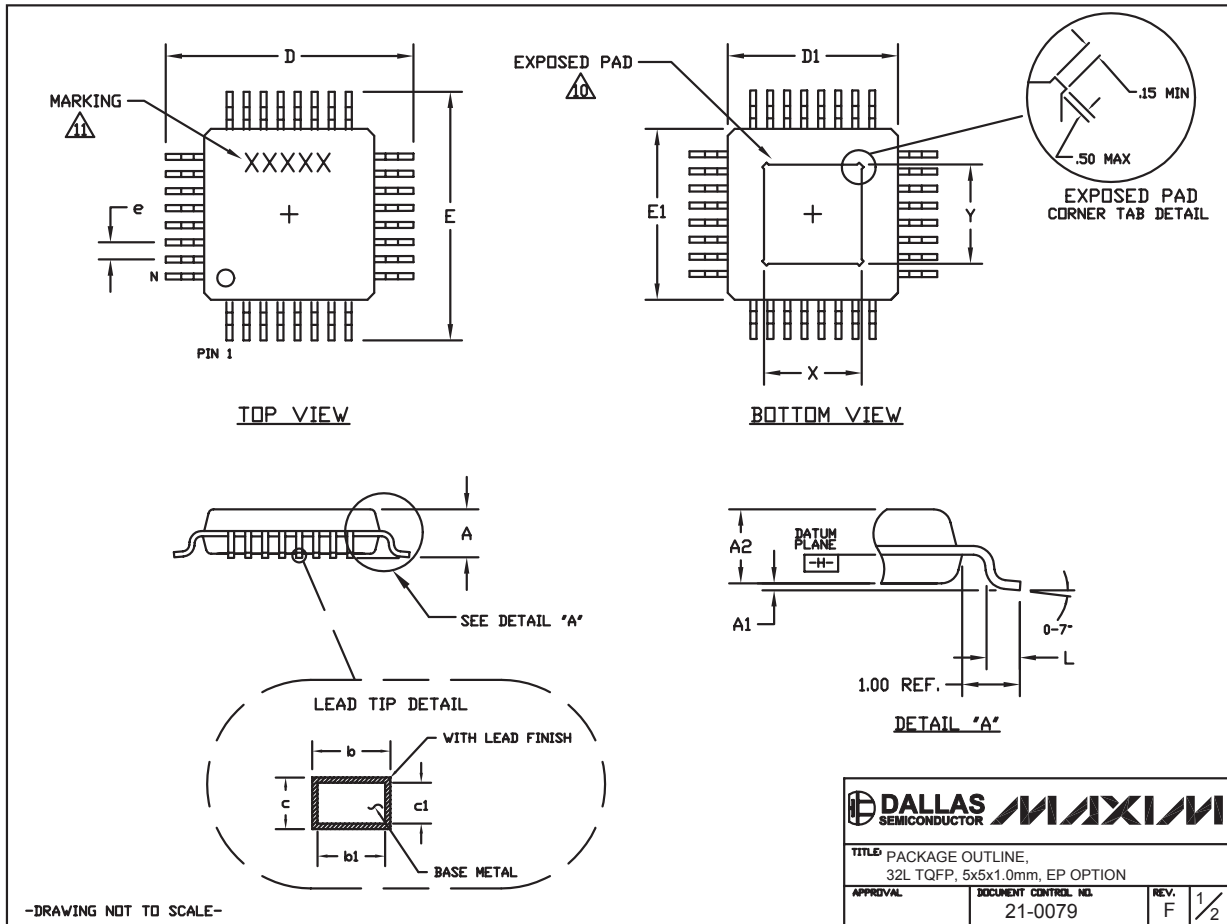

-DRAWING NOT TO SCALE-

| | | | |
|---|---------------------------------|--------------|-----|
| DALLAS SEMICONDUCTOR | | MAXIM | |
| TITLE: PACKAGE OUTLINE, 32L TQFP, 5x5x1.0mm, EP OPTION | | | |
| APPROVAL | DOCUMENT CONTROL NO. 21-0079 | REV. F | 1/2 |

(Package information continues on next page.)

+3.3V, 622Mbps SDH/SONET Laser Driver with Automatic Power Control

Package Information (continued)

NOTES:

1. ALL DIMENSIONING AND TOLERANCING CONFORM TO ANSI Y14.5-1982.
 2. DATUM PLANE \square IS LOCATED AT MOLD PARTING LINE AND COINCIDENT WITH LEAD, WHERE LEAD EXITS PLASTIC BODY AT BOTTOM OF PARTING LINE.
 3. DIMENSIONS D1 AND E1 DO NOT INCLUDE MOLD PROTRUSION. ALLOWABLE MOLD PROTRUSION IS 0.25 MM ON D1 AND E1 DIMENSIONS.
 4. THE TOP OF PACKAGE IS SMALLER THAN THE BOTTOM OF PACKAGE BY 0.15 MILLIMETERS.
 5. DIMENSION b DOES NOT INCLUDE DAMBAR PROTRUSION. ALLOWABLE DAMBAR PROTRUSION SHALL BE 0.08 MM TOTAL IN EXCESS OF THE b DIMENSION AT MAXIMUM MATERIAL CONDITION.
 6. ALL DIMENSIONS ARE IN MILLIMETERS.
 7. THIS OUTLINE CONFORMS TO JEDEC PUBLICATION 95, REGISTRATION MS-026.
 8. LEADS SHALL BE COPLANAR WITHIN .004 INCH.
 9. EXPOSED DIE PAD SHALL BE COPLANAR WITH BOTTOM OF PACKAGE WITHIN 2 MILS (.05 MM).
- \triangle DIMENSIONS X AND Y APPLY TO EXPOSED PAD (EP) VERSIONS ONLY. SEE INDIVIDUAL PRODUCT DATASHEET TO DETERMINE IF A PRODUCT USES EXPOSED PAD PACKAGE.
- \triangle MARKING IS FOR PACKAGE ORIENTATION REFERENCE ONLY.

| COMMON DIMENSIONS | | |
|---------------------------|-----------|------|
| DIMENSIONS IN MILLIMETERS | | |
| JEDEC AAA-HD | | |
| 5x5x1.0 MM | | |
| | MIN. | MAX. |
| A | \approx | 1.20 |
| A ₁ | 0.05 | 0.15 |
| A ₂ | 0.95 | 1.05 |
| D | 6.80 | 7.20 |
| D ₁ | 4.80 | 5.20 |
| E | 6.80 | 7.20 |
| E ₁ | 4.80 | 5.20 |
| L | 0.45 | 0.75 |
| N | 32 | |
| e | 0.50 BSC. | |
| b | 0.17 | 0.27 |
| b1 | 0.17 | 0.23 |
| c | 0.09 | 0.20 |
| c1 | 0.09 | 0.16 |
| X | 2.70 | 3.30 |
| Y | 2.70 | 3.30 |

| | | | |
|---|----------------------|------|-----|
|  | | | |
| TITLE: PACKAGE OUTLINE, 32L TQFP, 5x5x1.0mm, EP OPTION | | | |
| APPROVAL | DOCUMENT CONTRL. NO. | REV. | |
| | 21-0079 | F | 2/2 |

-DRAWING NOT TO SCALE-

Maxim makes no warranty, representation or guarantee regarding the suitability of its products for any particular purpose, nor does Maxim assume any liability arising out of the application or use of any product or circuit and specifically disclaims any and all liability, including without limitation consequential or incidental damages. "Typical" parameters can and do vary in different applications. All operating parameters, including "typicals" must be validated for each customer application by customer's technical experts. Maxim products are not designed, intended or authorized for use as components in systems intended for surgical implant into the body, or other applications intended to support or sustain life, or for any other application in which the failure of the Maxim product could create a situation where personal injury or death may occur.

12 **Maxim Integrated Products, 120 San Gabriel Drive, Sunnyvale, CA 94086 408-737-7600**

Looking for pricing, stock, or lifecycle information?

Click below to explore more details on WIN SOURCE:

 [View MAX3668EHJ+T on WIN SOURCE](#)

 [Maxim Integrated](#) Information

Optimize Your Supply Chain with WIN SOURCE Solutions

-  Global Sourcing Solution
-  Obsolete Management
-  Cost Control Management
-  Shortage Management
-  Alternative Solution
-  Excess Inventory Management