



**THE DATASHEET OF
MAX3656ETG+**





155Mbps to 2.5Gbps Burst-Mode Laser Driver

MAX3656

General Description

The MAX3656 is a burst-mode laser driver that operates at data rates from 155Mbps up to 2.5Gbps. The laser driver accepts either positive-referenced emitter-coupled logic (PECL) or current-mode logic (CML) data inputs and provides bias and modulation current for the laser diode. The device can switch the laser diode from a completely dark (off) condition to a full (on) condition (with proper bias and modulation currents) in less than 2ns. The MAX3656 incorporates DC-coupling between laser driver and laser diode and operates with a single-supply voltage as low as +3.0V.

A digital automatic power-control (APC) loop is provided to maintain the average optical power over the full temperature range and lifetime. The APC loop is functional for a minimum burst on-time of 576ns and minimum burst off-time of 96ns, with no limit on the maximum burst on- or off-time. A fail monitor is provided to indicate when the APC loop can no longer maintain the average power. The MAX3656 can be configured for nonburst-mode applications (continuous mode) by connecting burst enable (BEN) high. For power saving, the MAX3656 provides enabling and disabling functionality. The modulation current can be set from 10mA to 85mA and the bias current can be set from 1mA to 70mA.

The MAX3656 is packaged in a small, 24-pin, 4mm x 4mm thin QFN package and consumes only 132mW (typ), excluding bias and modulation currents.

Applications

Fiber-to-the-Home (FTTH) and Fiber-to-the-Business (FTTB) Broadband Access Systems
 Passive Optical Network (PON) Transmitters
 APON, EPON, and GPON Upstream Transmitters

Pin Configuration

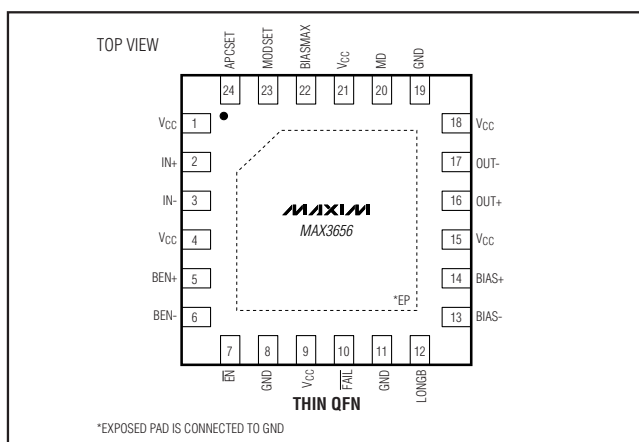

Features

- ◆ Multirate Operation from 155Mbps to 2.5Gbps
- ◆ Burst Enable/Disable Delay <2ns
- ◆ Burst On-Time of 576ns to Infinity
- ◆ Infinite Bias-Current Hold Time Between Bursts
- ◆ DC-Coupled Operation with Single +3.3V Power Supply
- ◆ 40mA Typical Supply Current
- ◆ Programmable Bias Current from 1mA to 70mA
- ◆ Programmable Modulation Current from 10mA to 85mA
- ◆ Automatic Average Power Control with Failure Monitor (No CAPC Capacitor Needed)
- ◆ APC Loop Initialization ≤ 3 Bursts

Ordering Information

PART	TEMP RANGE	PIN-PACKAGE
MAX3656ETG	-40°C to +85°C	24 Thin QFN-EP*
MAX3656ETG+	-40°C to +85°C	24 Thin QFN-EP*

+ Denotes a lead(Pb)-free/RoHS-compliant package.
 *EP = Exposed pad.

Functional Diagram appears at end of data sheet.

Typical Application Circuit

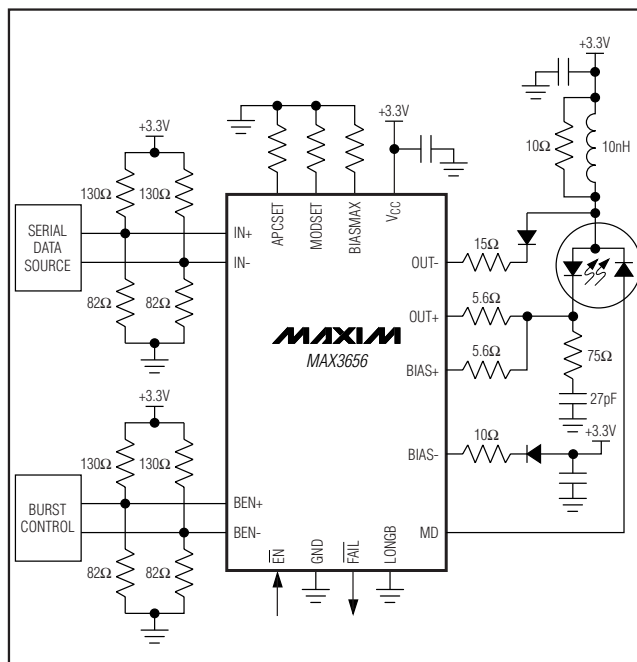

155Mbps to 2.5Gbps Burst-Mode Laser Driver

ABSOLUTE MAXIMUM RATINGS

Supply Voltage, V_{CC} -0.5V to +6.0V
 Current into BIAS+, BIAS-, OUT+, OUT- -20mA to +150mA
 Current into MD -5mA to +5mA
 Current into FAIL -10mA to +10mA
 Voltage at IN+, IN-, BEN+, BEN-, EN, LONGB -0.5V to ($V_{CC} + 0.5V$)
 Voltage at MODSET, APCSET, BIASMAX -0.5V to +3.0V
 Voltage at OUT+, OUT- +0.5V to ($V_{CC} + 1.5V$)
 Voltage at BIAS+, BIAS- +0.5V to ($V_{CC} + 0.5V$)

Continuous Power Dissipation ($T_A = +85^\circ\text{C}$)
 24-Lead Thin QFN
 (derate 27.8mW/ $^\circ\text{C}$ above +85 $^\circ\text{C}$) 1805mW
 Operating Ambient Temperature Range (T_A) -40 $^\circ\text{C}$ to +85 $^\circ\text{C}$
 Storage Ambient Temperature Range (T_{STG}) -55 $^\circ\text{C}$ to +150 $^\circ\text{C}$
 Lead Temperature (soldering, 10s) +300 $^\circ\text{C}$
 Soldering Temperature (reflow)
 Lead(Pb)-free +260 $^\circ\text{C}$
 Containing lead(Pb) +240 $^\circ\text{C}$

Stresses beyond those listed under "Absolute Maximum Ratings" may cause permanent damage to the device. These are stress ratings only, and functional operation of the device at these or any other conditions beyond those indicated in the operational sections of the specifications is not implied. Exposure to absolute maximum rating conditions for extended periods may affect device reliability.

OPERATING CONDITIONS

PARAMETER	SYMBOL	CONDITIONS	MIN	TYP	MAX	UNITS
Supply Voltage	V_{CC}		3.0	3.3	3.6	V
Supply Turn-On Time		10% to 90%	0.001		10	ms
Ambient Temperature			-40		+85	$^\circ\text{C}$
Data Mark Density		Average		50		%
Consecutive Identical Digits	CID				80	Bits
Data Rate			155		2500	Mbps
Monitor Diode Capacitance	C_{MD}	For minimum burst on-time (Note 1)			15	pF
Laser-to-Monitor Diode Gain	A_{LMD}	Δ (monitor current)/ Δ (laser current (above I_{TH})) (Notes 2, 3)	0.005		0.050	A/A
Extinction Ratio	r_e	$10 \log (P_1/P_0)$ (Note 3)	8.2		12.0	dB

Note 1: Larger MD capacitance increases the minimum burst on-time.

Note 2: Laser-to-monitor gain equals the laser slope efficiency multiplied by the photodiode responsivity multiplied by the losses due to laser-to-monitor diode coupling ($A_{LMD} = \eta_{LASER} \times \rho_{MONITORDIODE} \times L_{LASER-TO-MONITORDIODE}$), where L = laser-to-monitor diode coupling loss. A_{LMD} can also be calculated by:

$$A_{LMD} = \left(\frac{2 \times I_{MD}}{I_{MOD}} \right) \left(\frac{r_e - 1}{r_e + 1} \right)$$

where I_{MD} , I_{MOD} , and r_e (extinction ratio) are set externally.

Note 3: Operation outside this range degrades APC loop performance.

ELECTRICAL CHARACTERISTICS

(Typical values are at $V_{CC} = +3.3V$, $I_{BIAS} = 20mA$, $I_{MOD} = 25mA$, extinction ratio = 10dB, and $T_A = +25^\circ\text{C}$, unless otherwise noted.)

PARAMETER	SYMBOL	CONDITIONS	MIN	TYP	MAX	UNITS
POWER SUPPLY						
Power-Supply Current	I_{CC}	(Note 1)		40	70	mA
INPUT SPECIFICATIONS						
Differential Input Voltage	V_{IN}, V_{BEN}		0.2		1.6	V_{P-P}
Common-Mode Input Voltage	V_{CM}		$V_{CC} - 1.49$	$V_{CC} - 1.32$	$V_{CC} - V_{IN}/4$	V

155Mbps to 2.5Gbps Burst-Mode Laser Driver

MAX3656

ELECTRICAL CHARACTERISTICS (continued)

(Typical values are at $V_{CC} = +3.3V$, $I_{BIAS} = 20mA$, $I_{MOD} = 25mA$, extinction ratio = 10dB, and $T_A = +25^{\circ}C$, unless otherwise noted.)

PARAMETER	SYMBOL	CONDITIONS	MIN	TYP	MAX	UNITS
Single-Ended Input Voltage	V_{BEN+} , V_{BEN-}			0.8		V
\overline{EN} Input High Voltage	V_{IH}		2.0			V
\overline{EN} Input Low Voltage	V_{IL}				0.8	V
\overline{FAIL} Output High Voltage	V_{OH}	Sourcing 50 μ A, $V_{CC} = 3.0V$	2.4			V
\overline{FAIL} Output Low Voltage	V_{OL}	Sinking 100 μ A, $V_{CC} = 3.6V$			0.4	V
BIAS GENERATOR						
Bias-On Current Range	I_{BIAS}	Voltage at BIAS pin 0.6V	1		70	mA
Bias-Off Current Range	$I_{BIAS-OFF}$	$\overline{EN} = \text{high}$ or $BEN = \text{low}$, $V_{BIAS} \leq 2.6V$ (Note 2)		5	100	μ A
Bias-Current Temperature Stability		APC open loop	$I_{BIAS} = 70mA$	148		ppm/ $^{\circ}C$
			$I_{BIAS} = 15mA$	98		
Bias-Current Absolute Accuracy		APC open-loop $I_{BIAS} > 20mA$ (Note 3)	-15		+15	%
BIASMAX Current-Setting Range			15		70	mA
APC LOOP						
MD Reverse-Bias Voltage	V_{MD}	With respect to V_{CC}	1.6			V
MD Bias-Setting Stability (Note 4)		$I_{MD} = 50\mu A$	-750		+750	ppm/ $^{\circ}C$
		$I_{MD} = 1500\mu A$	-480		+480	
MD Bias-Setting Accuracy (Note 3)		$I_{MD} = 50\mu A$	-25		+25	%
		$I_{MD} = 1500\mu A$	-15		+15	
MD DC-Current Range	I_{MD}	Average current into MD pin	50		1500	μ A
APC Loop Initialization Time (Note 4)	t_{INIT}	Case 1 (Note 5) ($LONGB = 0$)		12		μ s
		Case 2 (Note 6) ($LONGB = 0$)		2.12		
		Case 3 (Note 7) ($LONGB = 0$)		1.60	1.92	
LASER MODULATOR						
Modulation ON Current Range	I_{MOD}	Data rate 1.25Gbps	10		85	mA
		Data rate > 1.25Gbps	10		60	
Modulation OFF Current	$I_{MOD-OFF}$	$\overline{EN} = \text{high}$ or $BEN = \text{low}$, $IN = \text{low}$ (Note 2)		16	150	μ A
Modulation-Current Stability		(Note 13)	-480		+480	ppm/ $^{\circ}C$
Modulation-Current Absolute Accuracy		$I_{MOD} > 15mA$ (Note 3)	-15		+15	%
Instantaneous Voltage at Modulator Output (OUT+)		$10mA \leq I_{MOD} < 60mA$	0.6			V
		$60mA \leq I_{MOD} \leq 85mA$	0.75			
Modulation-Current Rise Time	t_R	$10mA \leq I_{MOD} \leq 85mA$ (Notes 8, 13)		40	85	ps
Modulation-Current Fall Time	t_F	$10mA \leq I_{MOD} \leq 85mA$ (Notes 8, 13)		40	85	ps
Output Over-/Undershoot				20		%
Deterministic Jitter (Notes 9, 13)	DJ	155Mbps to 1.25Gbps, $10mA \leq I_{MOD} \leq 85mA$		17	45	pSP-P
		1.25Gbps to 2.5Gbps, $10mA \leq I_{MOD} \leq 60mA$		17	40	
Random Jitter	RJ	(Note 13)		0.8	1.4	pSRMS

155Mbps to 2.5Gbps Burst-Mode Laser Driver

ELECTRICAL CHARACTERISTICS (continued)

(Typical values are at $V_{CC} = +3.3V$, $I_{BIAS} = 20mA$, $I_{MOD} = 25mA$, extinction ratio = 10dB, and $T_A = +25^\circ C$, unless otherwise noted.)

PARAMETER	SYMBOL	CONDITIONS	MIN	TYP	MAX	UNITS
BURST-MODE SPECIFICATIONS						
Burst Enable Delay		APC closed loop (Notes 10, 11, 13)			2.3	ns
Burst Disable Delay		APC closed loop (Notes 10, 12, 13)			2.0	ns
Burst On-Time (Note 13)	t _{B-ON}	155Mbps	2881			ns
		622Mbps	720			
		1.25Gbps, 2.5Gbps	576			
Burst Off-Time (Note 13)	t _{B-OFF}	155Mbps	192			ns
		622Mbps	96			
		1.25Gbps, 2.5Gbps	96			
OPTICAL EVALUATION						
Optical Eye Diagram Mask Margin		ExceLight SLT2886-LR laser diode (or equivalent)	155.52Mbps	45		%
			622.08Mbps	40		
			1.24416Gbps	31		
			2.48832Gbps	24		

Note 1: Excludes I_{BIAS} and I_{MOD} . Maximum value is specified at $I_{MOD} = 85mA$, $I_{BIAS} = 70mA$, and $I_{MD} = 1.5mA$.

Note 2: For safety purposes, both the bias and modulation currents are switched off if any of the current set pins ($BIASMAX$, $MODSET$) are grounded.

Note 3: Accuracy refers to part-to-part variation.

Note 4: APC loop initialization definitions:

I_{BIAS} Error: $I_{BIAS} - I_{BIASSET}$, where I_{BIAS} = the actual bias current and $I_{BIASSET}$ = the level of bias current set by the R_{APCSET} resistor.

Initialization Case 1: Continuous Mode Power-Up. In this case, $\overline{EN} = \text{low}$, $BEN = \text{high}$, and then V_{CC} is ramped up from 0V to $\geq 3.0V$.

Initialization Case 2: Chip-Enable Reset. In this case, $3.0V \leq V_{CC} \leq 3.6V$, $BEN = \text{high}$, and then \overline{EN} changes from high to low.

Initialization Case 3: Burst-Mode Startup. In this case, $3.0V \leq V_{CC} \leq 3.6V$, $\overline{EN} = \text{low}$, and then BEN changes from low to high.

Note 5: I_{BIAS} error is less than 3.8mA (for an extinction ratio of 10dB and $I_{MD} = 1500\mu A$) within 12 μs from the time that $V_{CC} \geq 3.0V$.

Note 6: I_{BIAS} error is less than 3.8mA (for an extinction ratio of 10dB and $I_{MD} = 1500\mu A$) within 2.1 μs (typ) from the time that $\overline{EN} < 0.8V$.

Note 7: I_{BIAS} error must be less than 3.8mA (for an extinction ratio of 10dB and $I_{MD} = 1500\mu A$) at or before the end of the third burst following the transition of BEN from low to high. For the shortest burst on- and off-time (576ns and 96ns), this translates to 1.92 μs from when BEN toggles from low to high for the first time after startup.

Note 8: Rise and fall times are measured as 20% to 80% of the output amplitude with a repeating 0000011111.

Note 9: Deterministic jitter is measured with a continuous data pattern (no bursting) of $2^7 - 1$ PRBS + 80 consecutive ones + $2^7 - 1$ PRBS + 80 consecutive zeros.

Note 10: Measured electrically with a resistive load matched to the laser driver output.

Note 11: Enable delay is measured between (1) the time at which the rising edge of the differential burst enable input signal reaches the midpoint of the voltage swing, and (2) the time at which the combined output currents (bias and modulation) reach 90% of the final level set by R_{APCSET} , $R_{BIASMAX}$, and R_{MODSET} (after all transients such as overshoot, ringing, etc., have settled to within 10% of their final values). See Figure 1. Measurement done for $10mA \leq I_{MOD} \leq 85mA$ and $4mA \leq I_{BIAS} \leq 70mA$.

Note 12: Disable delay is measured between (1) the time at which the falling edge of the differential burst enable input signal reaches the midpoint of the voltage swing, and (2) the time at which the combined output currents (bias and modulation) fall below 10% of the bias on current (after transients have settled). See Figure 1. Measurement done for $10mA \leq I_{MOD} \leq 85mA$ and $4mA \leq I_{BIAS} \leq 70mA$.

Note 13: Guaranteed by design and characterization.

155Mbps to 2.5Gbps Burst-Mode Laser Driver

MAX3656

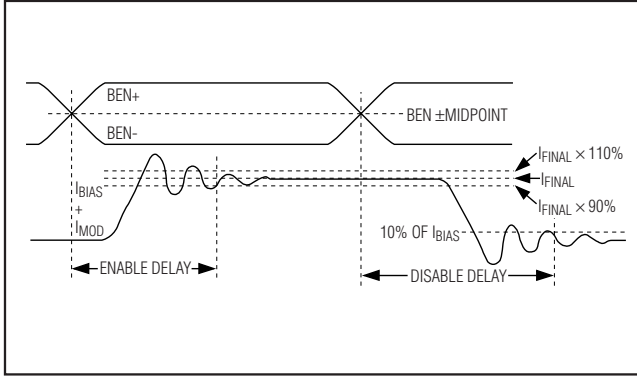

Figure 1. Enable and Disable Delay Times

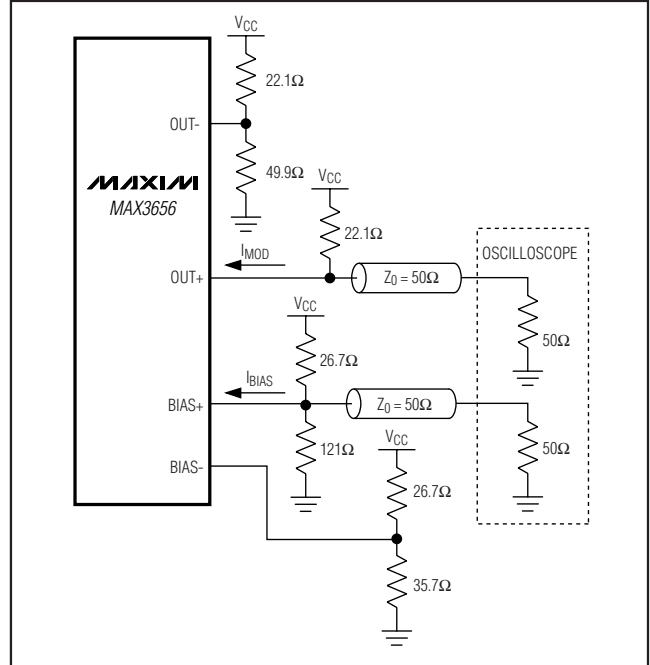
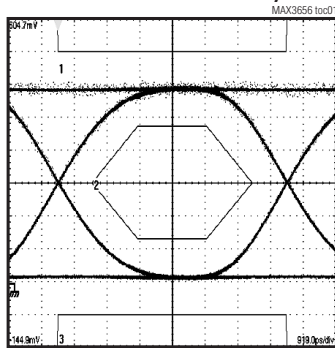

Figure 2. Output Termination for Characterization

Typical Operating Characteristics

($T_A = +25^\circ\text{C}$, unless otherwise noted.)

OPTICAL EYE DIAGRAM
(155.52Mbps, 117MHz FILTER,
PATTERN = 2²³ - 1 PRBS)



EXCELIGHT SLT2886-LR LASER
AVERAGE OPTICAL POWER = -6dBm
EXTINCTION RATIO = 15dB
MASK MARGIN = 45%

OPTICAL EYE DIAGRAM
(622.08Mbps, 467MHz FILTER,
PATTERN = 2²³ - 1 PRBS)

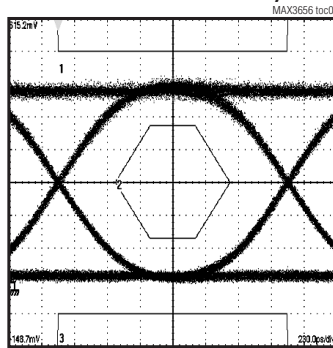

EXCELIGHT SLT2886-LR LASER
AVERAGE OPTICAL POWER = -6dBm
EXTINCTION RATIO = 15dB
MASK MARGIN = 40%

OPTICAL EYE DIAGRAM
(1.24416Gbps, 933MHz FILTER,
PATTERN = 2²³ - 1 PRBS)

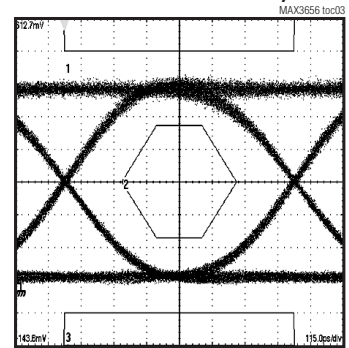

EXCELIGHT SLT2886-LR LASER
AVERAGE OPTICAL POWER = -6dBm
EXTINCTION RATIO = 12dB
MASK MARGIN = 31%

155Mbps to 2.5Gbps Burst-Mode Laser Driver

Typical Operating Characteristics (continued)

($T_A = +25^\circ\text{C}$, unless otherwise noted.)

OPTICAL EYE DIAGRAM
(2.48832Gbps, 2.3GHz FILTER,
PATTERN = 2²³ - 1 PRBS)

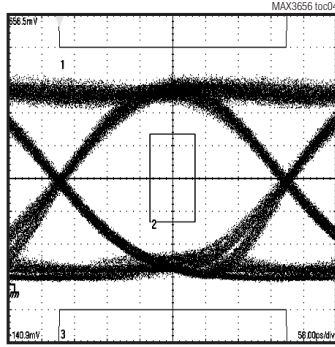

EXCELIGHT SLT2886-LR LASER
AVERAGE OPTICAL POWER = -6dBm
EXTINCTION RATIO = 10dB
MASK MARGIN = 24%

ELECTRICAL EYE DIAGRAM
(2.5Gbps, $I_{MOD} = 30\text{mA}$,
PATTERN = PRBS 2⁷ - 1 + 80 CID)

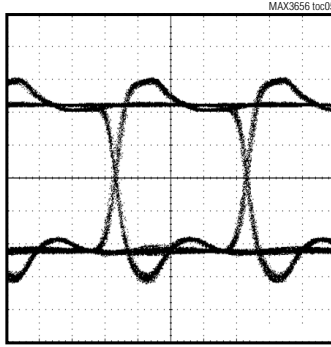

100ps/div

SUPPLY CURRENT vs. TEMPERATURE
(EXCLUDES I_{BIAS} , I_{MOD} , 15Ω LOAD)

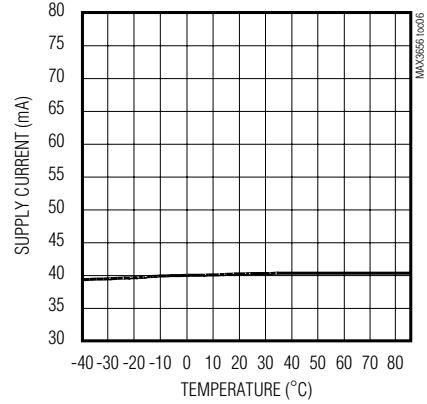

DETERMINISTIC JITTER vs. I_{MOD}

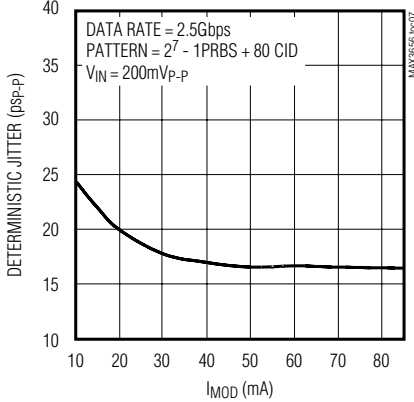

DETERMINISTIC JITTER vs. INPUT AMPLITUDE

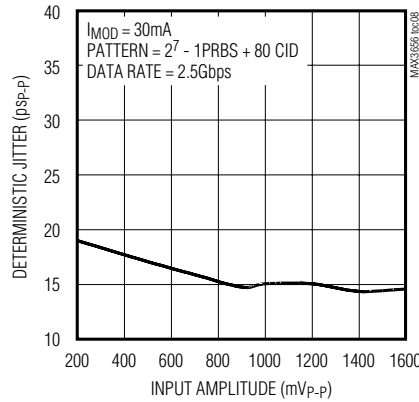

RANDOM JITTER vs. I_{MOD}

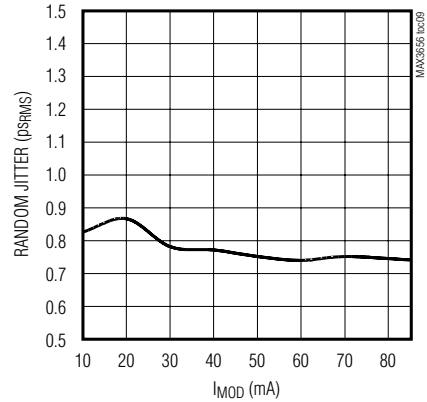

155Mbps to 2.5Gbps Burst-Mode Laser Driver

MAX3656

Typical Operating Characteristics (continued)

($T_A = +25^\circ\text{C}$, unless otherwise noted.)

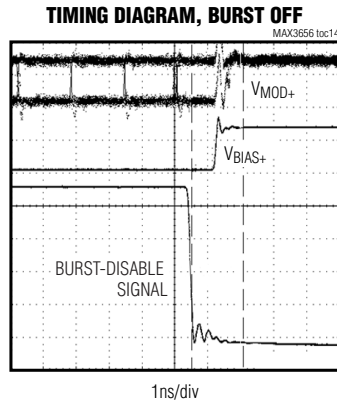
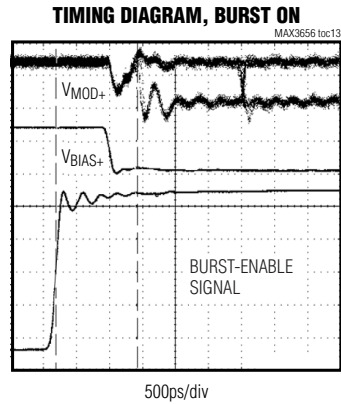
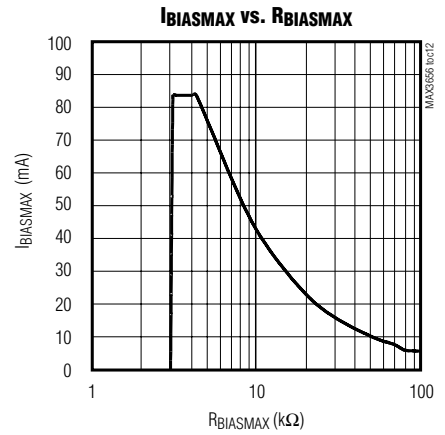
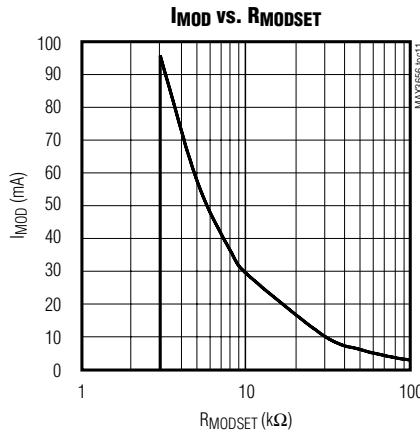
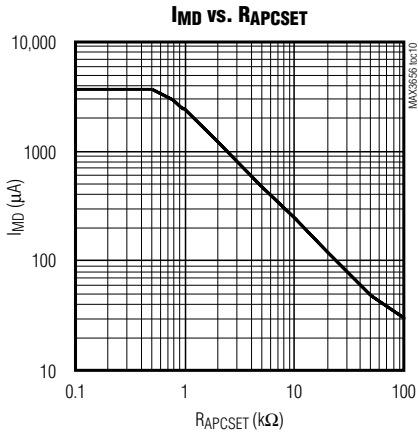

155Mbps to 2.5Gbps Burst-Mode Laser Driver

Pin Description

PIN	NAME	FUNCTION
1, 4, 9, 15, 18, 21	VCC	Power-Supply Voltage
2	IN+	Noninverting Data Input with On-Chip Biasing
3	IN-	Inverting Data Input with On-Chip Biasing
5	BEN+	Noninverting Burst-Enable Input with On-Chip Biasing
6	BEN-	Inverting Burst-Enable Input with On-Chip Biasing
7	$\overline{\text{EN}}$	TTL/CMOS Enable Input. Low for normal operation. Pull high or leave unconnected to disable laser bias and modulation currents.
8, 11, 19	GND	Power-Supply Ground
10	$\overline{\text{FAIL}}$	TTL/CMOS Failure Output. Indicates APC failure when low.
12	LONGB	TTL/CMOS Long Burst (See the <i>Setting the LONGB Input Pin</i> Section)
13	BIAS-	Inverting Laser Bias-Current Output. Connect through 10 Ω resistor and switching diode to VCC.
14	BIAS+	Noninverting Laser Bias-Current Output. Bias current flows into this pin when BEN is high. Minimize capacitance on this pin.
16	OUT+	Noninverting Laser Modulation-Current Output. Modulation current flows into this pin when BEN and IN are high.
17	OUT-	Inverting Laser Modulation-Current Output. Connect through 15 Ω resistor and switching diode to laser diode anode.
20	MD	Monitor Diode Input. Connect this pin to the anode of the monitor diode. Leave unconnected for open-loop operation. Minimize capacitance on this pin.
22	BIASMAX	Maximum Bias Current Set. A resistor connected from this pin to ground sets the maximum bias current. The bias current cannot exceed this level. The APC loop controls the bias current up to the level of the BIASMAX. For APC open-loop operation, this pin sets the laser bias current.
23	MODSET	Modulation Current Set. A resistor connected from this pin to ground sets the desired modulation current.
24	APCSET	Average Power Control Set. A resistor connected from this pin to ground sets the desired average optical power. Connect a 50k Ω resistor to ground for APC open-loop operation.
—	EP	Exposed Pad. Ground. This pad must be soldered to ground.

155Mbps to 2.5Gbps Burst-Mode Laser Driver

Detailed Description

The MAX3656 laser driver has three main parts: a high-speed modulator, a high-speed bias driver, and a laser-biasing block with automatic power control (see the *Functional Diagram*). Both the bias and modulation output stages are composed of differential pairs with programmable current sources. The circuit design is optimized for high-speed, low-voltage (3.3V), DC-coupled operation. The device is ideal for burst-mode operation with turn-on and turn-off times less than 2ns. The MAX3656 can be configured for nonburst-mode applications (continuous mode) by connecting BEN high.

Automatic Power Control

To maintain constant average optical power, the MAX3656 incorporates a digital automatic power-control (APC) loop to compensate for the changes in laser threshold current over temperature and lifetime. A back-facet photodiode mounted in the laser package converts the optical power into a photocurrent. The APC loop adjusts the laser bias current so the monitor current is matched to a reference current set by R_{APCSET}.

At startup, the APC loop traverses through a pseudo-binary search algorithm to set the proper monitor current that translates to the proper bias current. When BEN is high, the APC loop maintains constant optical power by digitally controlling the bias current. When BEN is low, the APC loop digitally stores the bias current value of the previous burst. The APC loop is reset in two ways, either power cycling or toggling the $\overline{\text{EN}}$ pin.

An external resistor (R_{BIASMAX}) sets the maximum allowable bias current during closed-loop operation and sets the bias current during open-loop operation. An APC failure flag ($\overline{\text{FAIL}}$) is set low during initialization and when the bias current cannot be adjusted to achieve the desired average optical power.

APC closed-loop operation requires that the user set three currents with external resistors connected between GND, BIASMAX, MODSET, and APCSET pins. Detailed guidelines for these resistor settings are described in the *Design Procedure* section.

If necessary, the MAX3656 is fully operational without APC. To operate the MAX3656 open loop, connect a 50k Ω resistor from APCSET to ground and leave the MD pin unconnected. In this case, two external resistors connected from BIASMAX and MODSET to GND directly set the laser current.

APC Failure Monitor

The MAX3656 provides an APC failure monitor (TTL) to indicate an APC loop-tracking failure. $\overline{\text{FAIL}}$ is set low when the APC loop cannot adjust the bias current to

maintain the desired monitor current. For example, the laser diode requires more bias current (to maintain a constant optical output) than maximum bias current set by R_{BIASMAX}. The bias current is limited and $\overline{\text{FAIL}}$ is asserted. In an alternate example, assume that a circuit failure causes the cathode of the laser diode to be shorted to GND, thereby causing an uncontrolled high optical output. In this case, the APC loop cannot decrease the user current, and $\overline{\text{FAIL}}$ is asserted. $\overline{\text{FAIL}}$ is also set low during initialization.

Slow-Start

For safety reasons, at initial power-up or after toggling $\overline{\text{EN}}$, the MAX3656 incorporates a slow-start circuit that provides a typical delay of 450ns during the beginning of APC loop initialization.

Enable Control

The MAX3656 features a chip-enable function. When $\overline{\text{EN}}$ is high, the bias and modulation currents are off and the digital state of the APC loop is reset. When $\overline{\text{EN}}$ is toggled from a high to a low, the APC loop begins initialization. The initialization time is typically 2.1 μ s (LONGB = low) and 3.72 μ s (LONGB = high).

APC Loop Initialization

The digital APC loop is reset whenever the power is turned off and/or the $\overline{\text{EN}}$ input is driven high. When power is turned on or when $\overline{\text{EN}}$ is toggled low, the APC loop automatically performs an initialization routine that quickly adjusts the bias current from its reset level to its initialized level. The initialized bias current level is defined to be within 3.8mA of the final bias current level set by the APCSET resistor. Once initialized, the APC loop enters its fine-adjustment mode of operation and adjusts the bias current to match the level set by the APCSET resistor. There are three different cases in which the APC loop starts initialization, and each has a unique initialization time. These cases are defined as follows:

- **Continuous-Mode Power-Up**

In continuous-mode power-up, the chip is enabled ($\overline{\text{EN}}$ = low) and the burst-enable input is high (BEN = high) when power is applied to the laser driver. APC loop initialization begins when the power-supply voltage rises above the minimum specified limit of +3.0V. The BEN input remains high indefinitely and the laser driver operates in continuous (nonbursting) mode. In this case, the initialization time is 12 μ s (typ).

- **Chip-Enable Reset**

In chip-enable reset, the power-supply voltage is within the specified limits and BEN is high. The chip-enable input ($\overline{\text{EN}}$) is initially high (chip disabled and

155Mbps to 2.5Gbps Burst-Mode Laser Driver

APC loop reset), and then it is driven low (chip-enabled). In this case, APC loop initialization begins when the voltage at $\overline{\text{EN}}$ drops below the specified $\overline{\text{EN}}$ input low voltage of 0.8V. After initialization begins, the laser driver can be operating in burst mode (BEN toggling high and low) or continuous mode (BEN = high). In this case, the initialization time is 2.1 μs (typ).

• Burst-Mode Startup

In burst-mode startup, the power-supply voltage is within the specified limits and the chip is enabled ($\overline{\text{EN}}$ = low). The burst-enable input is low (BEN = low) and has not been in the high state since the APC loop was reset. APC loop initialization begins when the BEN input is driven high. After initialization begins, the laser driver can be operating in burst mode (BEN toggling high and low) or continuous mode (BEN = high). In this case, the initialization time is 1.6 μs (typ).

In each of the three cases listed, initialization is complete within three bursts (bursts must comply with specified burst on- and burst off-time) or the time specified in the *Electrical Characteristics* table, whichever comes first.

Burst-Mode Operation

The bias and modulation outputs (BIAS+ and OUT+) can be switched on and off quickly using the differential burst-enable inputs (BEN+ and BEN-). Once the APC loop has initialized, the bias and modulation outputs are switched on when BEN+ = high and BEN- = low and are switched off when BEN+ = low and BEN- = high.

When BEN is switched on, the laser driver sinks the bias and modulation currents set by the APCSET, BIASMAX, and MODSET resistors within the maximum BEN delay time of 2.3ns. For stable APC loop operation, the minimum burst length is limited to the burst on-time listed in the *Electrical Characteristics* table. The maximum burst-on time is unlimited.

When BEN is switched off, the bias and modulation currents fall below the specified bias-off and modulation-off currents within the maximum burst disable delay time of 2.0ns. For stable APC loop operation, the minimum burst off-time is limited to the value listed in the *Electrical Characteristics* table. The maximum burst off-time is unlimited.

Short-Circuit Protection

The MAX3656 provides short-circuit protection for the modulation and bias-current sources. If BIASMAX or MODSET is shorted to ground, the bias and modulation outputs are turned off.

Design Procedure

When designing a laser transmitter, the optical output is usually expressed in terms of average power and extinction ratio. Table 1 shows the relationships helpful in converting between the optical average power and the modulation current. These relationships are valid if the mark density and duty cycle of the optical waveform are 50%.

Programming the Modulation Current

For a given laser power (P_{AVG}), slope efficiency (η), and extinction ratio (r_e), the modulation current can be calculated using Table 1. See the I_{MOD} vs. R_{MODSET} graph in the *Typical Operating Characteristics*, and select the value of R_{MODSET} that corresponds to the required current at +25°C.

Programming the Bias Current

When the MAX3656 is used in open-loop operation, the R_{BIASMAX} resistor determines the bias current. To select this resistor, determine the required bias current. See the I_{BIASMAX} vs. R_{BIASMAX} graph in the *Typical Operating Characteristics*, and select the value of R_{BIASMAX} that corresponds to the required current. For open-loop operation, connect a 50k Ω resistor from R_{APCSET} to GND, and leave the MD pin open.

When using the MAX3656 in closed-loop operation, the R_{BIASMAX} resistor sets the maximum bias current available to the laser diode over temperature and lifetime. The APC loop can subtract from this maximum value, but cannot add to it. See the I_{BIASMAX} vs. R_{BIASMAX} graph in the *Typical Operating Characteristics* and select the value of R_{BIASMAX} that corresponds to the end-of-life bias current at +85°C. The R_{BIASMAX} resistor should not be set less than 5k Ω .

Table 1. Optical Power Definition

PARAMETER	SYMBOL	RELATION
Average power	P_{AVG}	$P_{\text{AVG}} = (P_0 + P_1) / 2$
Extinction ratio	r_e	$r_e = P_1 / P_0$
Optical power high	P_1	$P_1 = 2P_{\text{AVG}} \times r_e / (r_e + 1)$
Optical power low	P_0	$P_0 = 2P_{\text{AVG}} / (r_e + 1)$
Optical amplitude	$P_{\text{P-P}}$	$P_{\text{P-P}} = P_1 - P_0$
Laser slope efficiency	η	$\eta = P_{\text{P-P}} / I_{\text{MOD}}$
Modulation current	I_{MOD}	$I_{\text{MOD}} = P_{\text{P-P}} / \eta$
Laser-to-monitor diode gain	A_{LMD}	$(2 \times I_{\text{MD}} / I_{\text{MOD}})((r_e - 1) / (r_e + 1))$

155Mbps to 2.5Gbps Burst-Mode Laser Driver

Programming the APC Loop

When using the MAX3656's APC feature, program the average optical power by adjusting the APCSET resistor. To select this resistor, determine the desired monitor current to be maintained over temperature and lifetime. See the IMD vs. RAPCSET graph in the *Typical Operating Characteristics* and select the value of RAPCSET that corresponds to the required current.

Setting the LONGB Input Pin

Set the LONGB pin according to Table 2 to optimize APC loop operation.

Interfacing with Laser Diodes

The laser modulation current output OUT+ is optimized to drive a 15Ω load and must be DC-coupled. A series damping resistor, R_D, provides impedance matching to the laser diode. The combined value of the series damping resistor and the laser diode equivalent series resistance should be close to 15Ω. An RC shunt compensation network, R_{COMP}/C_{COMP}, connected between the laser diode cathode and ground should be provided to reduce optical output aberrations and duty-cycle distortion caused by laser diode parasitic inductance. The values of R_{COMP} and C_{COMP} can be adjusted to match the laser diode and PC board layout characteristics for optimal optical eye performance (refer to Application Note 274: *HFAN-02.0: Interfacing Maxim's Laser Drivers with Laser Diodes*). The OUT- pin is connected through a 15Ω resistor and switching diode to the laser diode anode. The switching diode at OUT- improves the optical output eye and burst-enable delay by better matching the laser diode characteristics.

For data rates greater than 1Gbps, a parallel RL peaking network, R_P/L_P, connected between the laser diode anode and V_{CC} is recommended. This network creates a differential drive for the laser diode to improve rise/fall times and reduce jitter. The values of R_P and L_P are also adjusted to match the laser diode and PC board layout characteristics for optimal optical eye performance.

Current in the BIAS output switches at high speed when bursting; therefore, the BIAS+ pin should be connected directly through a resistor, equal to R_D as determined above, to the laser diode cathode. The

BIAS- pin is connected through a 10Ω resistor and switching diode to V_{CC}.

Input Termination Requirements

The MAX3656 data and BEN inputs are internally biased. Although the inputs are compatible with LVPECL signals, it is not necessary to drive the MAX3656 with a standard LVPECL signal. While DC-coupled, the MAX3656 operates properly as long as the specified common-mode voltage and differential voltage swings are met. Because of the on-chip biasing network (Figure 3), the MAX3656 inputs self-bias to the proper operating point to accommodate AC-coupling.

See Figures 4 and 5 for connecting to PECL or CML data outputs.

Table 2. Setting the LONGB Input Pin

LONGB	CONDITION
0	Burst on-time ≤ 1.2μs
0 or 1	Burst on-time > 1.2μs or continuous mode operation
1	Data rates of 155Mbps

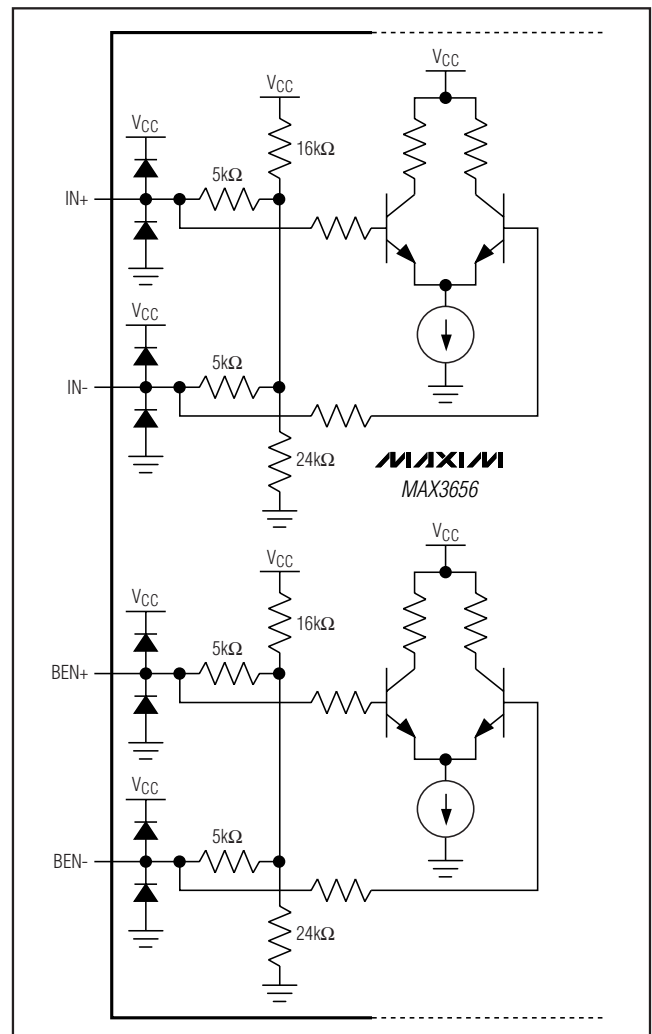

Figure 3. MAX3656 Internal Biasing

155Mbps to 2.5Gbps Burst-Mode Laser Driver

Design Example

Select Laser

Select a communication-grade laser for the proper data rate. Assume the laser output average power is $P_{AVG} = 0\text{dBm}$, the operating temperature is -40°C to $+85^{\circ}\text{C}$, and the laser diode has the following characteristics: wavelength: $\lambda = 1.3\mu\text{m}$, threshold current: $I_{TH} = 22\text{mA}$ at $+25^{\circ}\text{C}$, threshold temperature coefficient: $\beta_{TH} = 1.3\%/^{\circ}\text{C}$, laser-to-monitor transfer: $\rho_{MON} = 0.2\text{A/W}$ ($\rho_{MON} = \rho_{MONITORDIODE} \times L_{LASER-TO-MONITORDIODE}$), and laser slope efficiency: $\eta = 0.05\text{mW/mA}$ at $+25^{\circ}\text{C}$.

Determining R_{APCSET}

The desired monitor diode current is estimated by $I_{MD} = P_{AVG} \times \rho_{MON} = 200\mu\text{A}$. The I_{MD} vs. R_{APCSET} graph in the *Typical Operating Characteristics* shows R_{APCSET} at $12\text{k}\Omega$.

Determining R_{MODSET}

Assuming $r_e = 10$ and an average power of 0dBm (1mW), the peak-to-peak optical power $P_{P-P} = 1.64\text{mW}$ (Table 1). The required modulation current is $1.64\text{mW}/0.05\text{mW/mA} = 32.8\text{mA}$. The I_{MOD} vs. R_{MODSET} graph in the *Typical Operating Characteristics* shows R_{MODSET} at $9\text{k}\Omega$.

Determining $R_{BIASMAX}$

Determine the maximum threshold current ($I_{TH(MAX)}$) at $T_A = +85^{\circ}\text{C}$ and end of life. Assuming ($I_{TH(MAX)} = 50\text{mA}$), the maximum bias current should be:

$$I_{BIASMAX} = I_{TH(MAX)}$$

In this example, $I_{BIASMAX} = 50\text{mA}$. The $I_{BIASMAX}$ vs. $R_{BIASMAX}$ graph in the *Typical Operating Characteristics* shows $R_{BIASMAX}$ at $8\text{k}\Omega$.

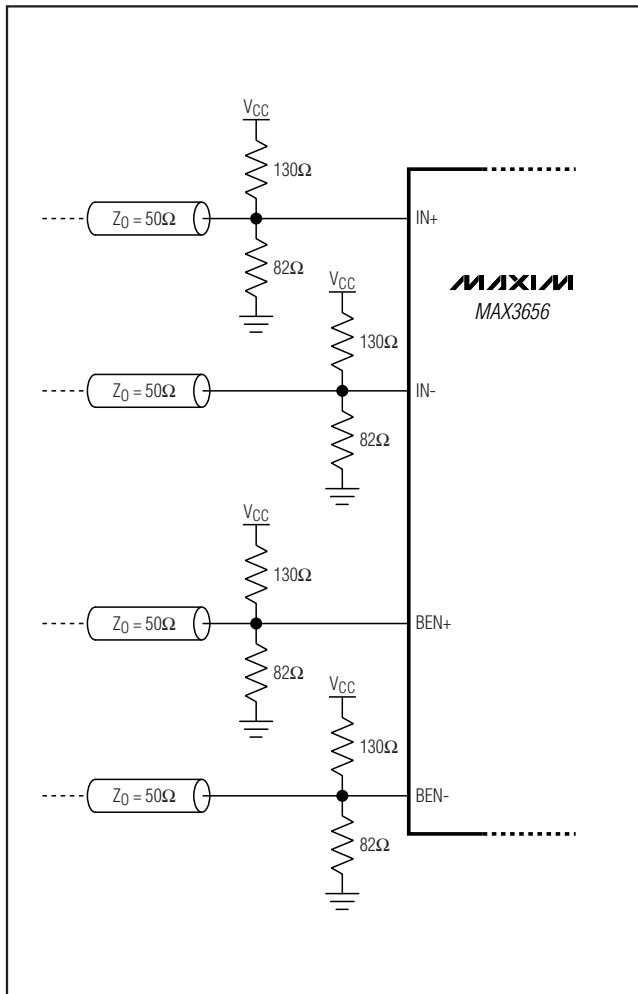

Figure 4. Connecting to PECL Outputs

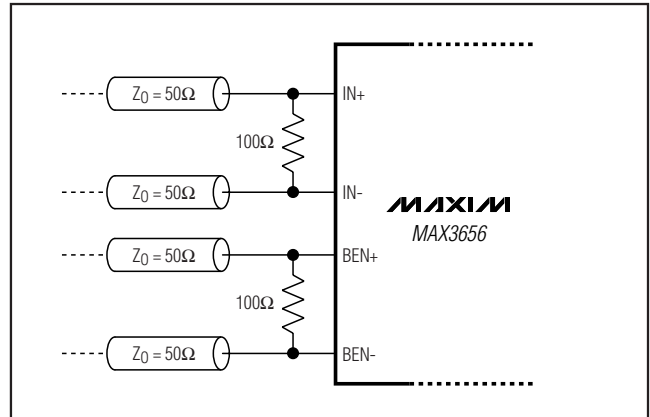

Figure 5. Connecting to CML Outputs

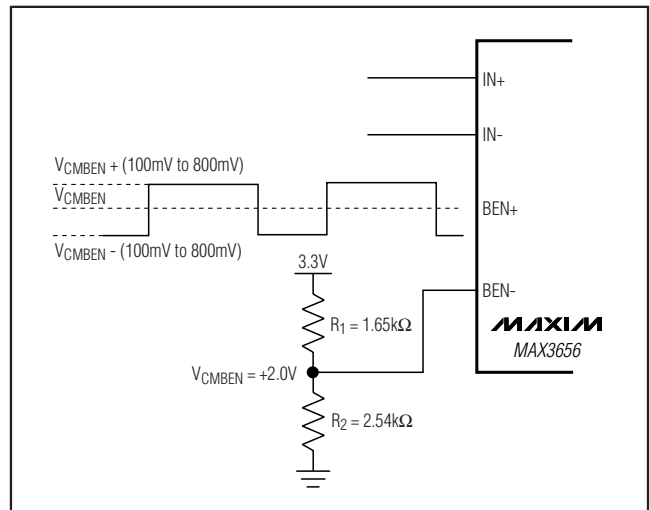

Figure 6. Single-Ended Biasing for Burst Enable

155Mbps to 2.5Gbps Burst-Mode Laser Driver

MAX3656

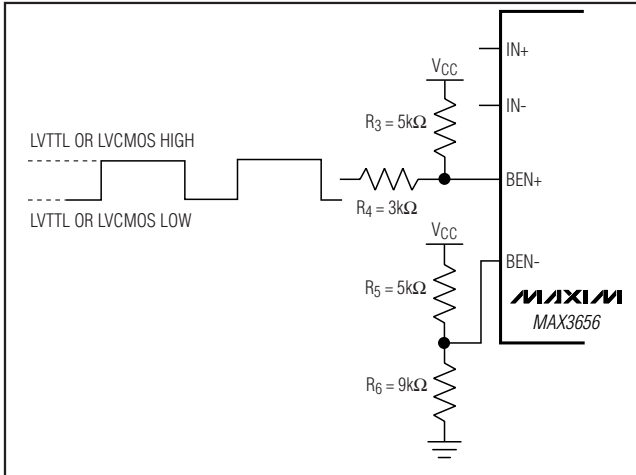

Figure 7. Single-Ended LVTTTL or LVCMOS Biasing for Burst Enable

Applications Information

Running Burst Enable Single-Ended

With PECL signal levels, for single-ended operation of burst enable, connect the BEN+ to the burst-enable control. Connect a resistor (R_1) from VCC to BEN- and resistor (R_2) from BEN- to ground. The parallel combination of R_1 and R_2 should be less than $1k\Omega$. Choose the values of R_1 and R_2 to set the common-mode voltage in the range defined in the *Electrical Characteristics* table (see Figure 6).

With LVTTTL or LVCMOS signal levels, for single-ended operation of burst enable connect a $3k\Omega$ (R_4) resistor

from the burst-enable signal to BEN+. Connect a $5k\Omega$ (R_3) resistor from VCC to BEN+. Connect a $5k\Omega$ resistor (R_5) from VCC to BEN- and a $9k\Omega$ resistor (R_6) from BEN- to ground. For typical LVTTTL or LVCMOS specifications of VCC to 2.0V for a high and 0.8V to 0V for a low, the LVTTTL or LVCMOS sources a maximum of $75\mu A$ and sinks a maximum of $500\mu A$. See Figure 7 for setting up the single-ended LVTTTL or LVCMOS biasing for burst enable.

Layout Considerations

To minimize inductance, keep the connections between the MAX3656 output pins and laser diode as close as possible. Place a bypass capacitor as close as possible to each VCC connection. Take extra care to minimize stray parasitic capacitance on the BIAS and MD pins. Use good high-frequency layout techniques and multilayer boards with uninterrupted ground planes to minimize EMI and crosstalk.

Laser Safety and IEC825

Using the MAX3656 laser driver alone does not ensure that a transmitter design is compliant with IEC825. The entire transmitter circuit and component selections must be considered. Each user must determine the level of fault tolerance required by the application, recognizing that Maxim products are neither designed nor authorized for use as components in systems intended for surgical implant into the body, for applications intended to support or sustain life, or for any other application in which the failure of a Maxim product could create a situation where personal injury or death can occur.

155Mbps to 2.5Gbps Burst-Mode Laser Driver

Revision History

REVISION NUMBER	REVISION DATE	DESCRIPTION	PAGES CHANGED
0	3/03	Initial release	—
1	5/04	Added the lead-free package to the <i>Ordering Information</i> table	1
2	10/04	Added the package code for the lead-free package to the <i>Ordering Information</i> table; updated the <i>Operating Conditions</i> table; updated the <i>Running Burst Enable Singled-Ended</i> section; added the <i>Design Example</i> section; updated Figure 7; added the <i>Burst Enable Delay</i> section; updated the <i>Chip Topography</i> diagram	1, 2, 11, 12, 14
3	7/10	Removed the dice and package code information from the <i>Ordering Information</i> table; replaced the <i>Typical Application Circuit</i> ; added the soldering temperature to the <i>Absolute Maximum Ratings</i> section; updated the optical eye mask margins in the <i>Electrical Characteristics</i> table; updated the optical eye diagrams and added 2.488Gbps eye diagram in the <i>Typical Operating Characteristics</i> section; updated the descriptions for pins 13 and 17 with diodes in the <i>Pin Description</i> table; removed redundant text in the <i>Detailed Description</i> ; replaced the <i>Interfacing with Laser Diodes</i> section; deleted the bonding coordinates (Table 3 and <i>Burst Enable Delay</i> and <i>Wire-Bonding Die</i> sections); replaced the <i>Functional Diagram</i> ; deleted the <i>Chip Topography</i> section; added the <i>Package Information</i> table	1, 2, 5–9, 11, 13, 14
4	9/10	Removed the operating junction temperature range from the <i>Absolute Maximum Ratings</i> section; added a sentence stating the minimum R _{BIASMAX} value to the <i>Programming the Bias Current</i> section	2, 10

MAX3656

Maxim cannot assume responsibility for use of any circuitry other than circuitry entirely embodied in a Maxim product. No circuit patent licenses are implied. Maxim reserves the right to change the circuitry and specifications without notice at any time.

Maxim Integrated Products, 120 San Gabriel Drive, Sunnyvale, CA 94086 408-737-7600 _____ 15

Looking for pricing, stock, or lifecycle information?

Click below to explore more details on WIN SOURCE:

 [View MAX3656ETG+](#) on WIN SOURCE

 [Maxim Integrated](#) Information

Optimize Your Supply Chain with WIN SOURCE Solutions

-  Global Sourcing Solution
-  Obsolete Management
-  Cost Control Management
-  Shortage Management
-  Alternative Solution
-  Excess Inventory Management