



**THE DATASHEET OF
MAX351ESE+**





Precision, Quad, SPST Analog Switches

MAX351/MAX352/MAX353

General Description

The MAX351/MAX352/MAX353 are precision, quad, single-pole single-throw (SPST) analog switches. The MAX351 has four normally closed (NC), and the MAX352 has four normally open (NO) switches. The MAX353 has two NO and two NC switches. All three parts offer low on resistance (less than 35Ω), guaranteed to match within 2Ω between channels and to remain flat over the analog signal range (Δ3Ω max). They also offer low leakage (less than 250pA at +25°C and less than 6nA at +85°C) and fast switching (turn-on time less than 175ns and turn-off time less than 145ns).

The MAX351/MAX352/MAX353 are fabricated with Maxim's new improved 44V silicon-gate process. Design improvements guarantee extremely low charge injection (10pC), low power consumption (35μW), and electrostatic discharge (ESD) greater than 2000V. The 44V maximum breakdown voltage allows rail-to-rail analog signal handling.

These monolithic switches operate with a single positive supply (+10V to +30V) or with split supplies (±4.5V to ±20V) while retaining CMOS-logic input compatibility and fast switching. CMOS inputs provide reduced input loading.

Applications

Sample-and-Hold Circuits Military Radios
 Guidance and Control Systems Communications Systems
 Heads-Up Displays Battery-Operated Systems
 Test Equipment PBX, PABX

Features

- ◆ Low On Resistance < 22Ω Typical (35Ω Max)
- ◆ Guaranteed Matched On Resistance Between Channels < 2Ω
- ◆ Guaranteed Flat On Resistance Over Analog Signal Range Δ3Ω Max
- ◆ Guaranteed Charge Injection < 10pC
- ◆ Guaranteed Off-Channel Leakage < 6nA at +85°C
- ◆ ESD Guaranteed > 2000V per Method 3015.7
- ◆ Single-Supply Operation (+10V to +30V)
 Bipolar-Supply Operation (±4.5V to ±20V)
- ◆ TTL-/CMOS-Logic Compatibility
- ◆ Rail-to-Rail Analog Signal Handling Capability

Ordering Information

PART	TEMP RANGE	PIN-PACKAGE
MAX351CPE	0°C to +70°C	16 Plastic DIP
MAX351CSE	0°C to +70°C	16 Narrow SO
MAX351C/D	0°C to +70°C	Dice*
MAX351EGE	-40°C to +85°C	16 QFN
MAX351EPE	-40°C to +85°C	16 Plastic DIP
MAX351ESE	-40°C to +85°C	16 Narrow SO
MAX351EJE	-40°C to +85°C	16 CERDIP
MAX351MJE	-55°C to +125°C	16 CERDIP

Ordering Information continued at end of data sheet.
 *Contact factory for availability and processing to MIL-STD-883.

Pin Configurations/Functional Diagrams/Truth Tables

TOP VIEW

DIP/SO
MAX351

LOGIC	SWITCH
0	ON
1	OFF

DIP/SO
MAX352

LOGIC	SWITCH
0	OFF
1	ON

DIP/SO
MAX353

LOGIC	SWITCHES 1, 4	SWITCHES 2, 3
0	OFF	ON
1	ON	OFF

Pin Configuration continued at end of data sheet. SWITCHES SHOWN FOR LOGIC "0" INPUT



For pricing, delivery, and ordering information, please contact Maxim/Dallas Direct! at 1-888-629-4642, or visit Maxim's website at www.maxim-ic.com.

Precision, Quad, SPST Analog Switches

ABSOLUTE MAXIMUM RATINGS

Voltage Referenced to V-

V+	44V
GND	25V
VL	(GND - 0.3V) to (V+ + 0.3V)
Digital Inputs, V _{COM} , V _{NC} , V _{NO} (Note 1)	(V- - 2V) to (V+ + 2V) or 30mA (whichever occurs first)
Current (any terminal)	30mA
Peak Current COM ₋ , NO ₋ , NC ₋ (pulsed at 1ms, 10% duty cycle max)	100mA
ESD per Method 3015.7	>2000V

Continuous Power Dissipation (T_A = +70°C) (Note 2)

Plastic DIP (derate 10.53mW/°C above +70°C)	842mW
Narrow SO (derate 8.70mW/°C above +70°C)	696mW
QFN (derate 19.2mW/°C above +70°C)	1538mW
CERDIP (derate 10.00mW/°C above +70°C)	800mW

Operating Temperature Ranges:

MAX35_C_	0°C to +70°C
MAX35_E_	-40°C to +85°C
MAX35_MJE	-55°C to +125°C

Storage Temperature Range

Lead Temperature (soldering, 10s)

Note 1: Signals on NC₋, NO₋, COM₋, or IN₋ exceeding V+ or V- will be clamped by internal diodes. Limit forward diode current to maximum current rating.

Note 2: All leads are soldered or welded to PC board.

Stresses beyond those listed under "Absolute Maximum Ratings" may cause permanent damage to the device. These are stress ratings only, and functional operation of the device at these or any other conditions beyond those indicated in the operational sections of the specifications is not implied. Exposure to absolute maximum rating conditions for extended periods may affect device reliability.

ELECTRICAL CHARACTERISTICS—Dual Supplies

(V+ = 15V, V- = -15V, VL = 5V, GND = 0V, V_{INH} = 2.4V, V_{INL} = 0.8V, T_A = T_{MIN} to T_{MAX}, unless otherwise noted.)

PARAMETER	SYMBOL	CONDITIONS	MIN	TYP (Note 3)	MAX	UNITS
SWITCH						
Analog Signal Range	V _{COM-} , V _{NO-} , V _{NC-}	(Notes 1, 4)	V-		V+	V
On Resistance	R _{ON}	I _{COM} = -10mA, V _{NO-} or V _{NC-} = ±8.5V, V+ = 13.5V, V- = -13.5V	T _A = +25°C	C, E M	17 35	Ω
			T _A = T _{MIN} to T _{MAX}		17 30	
On Resistance Match Between Channels (Note 5)	R _{ON}	I _{COM} = -10mA, V _{NO-} or V _{NC-} = ±10V, V+ = 15V, V- = -15V	T _A = +25°C		2	Ω
			T _A = T _{MIN} to T _{MAX}		4	
On Resistance Flatness (Note 5)	R _{ON}	I _{COM} = -10mA, V _{NO-} or V _{NC-} = ±5V, V+ = 15V, V- = -15V	T _A = +25°C		3	Ω
			T _A = T _{MIN} to T _{MAX}		5	
Off Leakage Current (NO ₋ or NC ₋)	I _{NO} I _{NC}	V _{COM} = -15.5V, V _{NO-} or V _{NC-} = 15.5V, V+ = 16.5V, V- = -16.5V	T _A = +25°C		-0.25 -0.10 0.25	nA
			T _A = T _{MIN} to T _{MAX}	C, E M	-6 20	
					-20 20	
COM ₋ Off Leakage Current	I _{NC(OFF)}	V _{COM} = -15.5V, V _{NO-} or V _{NC-} = 15.5V, V+ = 16.5V, V- = -16.5V	T _A = +25°C		-0.25 -0.10 0.25	nA
			T _A = T _{MIN} to T _{MAX}	C, E M	-6 20	
					-20 20	
COM ₋ On Leakage Current	I _{COM(ON)}	V _{COM} = ±15.5V, V _{NO-} or V _{NC-} = ±15.5V, V+ = 16.5V, V- = -16.5V	T _A = +25°C		-0.4 -0.1 0.4	nA
			T _A = T _{MIN} to T _{MAX}	C, E M	-10 10	
					-40 40	

Precision, Quad, SPST Analog Switches

MAX351/MAX352/MAX353

ELECTRICAL CHARACTERISTICS—Dual Supplies (continued)

(V+ = 15V, V- = -15V, VL = 5V, GND = 0V, VINH = 2.4V, VINL = 0.8V, TA = TMIN to TMAX, unless otherwise noted.)

PARAMETER	SYMBOL	CONDITIONS	MIN	TYP (Note 3)	MAX	UNITS	
INPUT							
Input Current with Input Voltage High	I _{INH}	IN ₋ = 2.4V, all others = 0.8V	-0.500	0.005	0.500	μA	
Input Current with Input Voltage Low	I _{INL}	IN ₋ = 0.8V, all others = 2.4V	-0.500	0.005	0.500	μA	
SUPPLY							
Power-Supply Range			±4.5		±20.0	V	
Positive Supply Current	I+	All channels on or off, VIN = 0V or 5V, V+ = 16.5V V- = -16.5V	TA = +25°C	-1	0.0001	1	μA
			TA = TMIN to TMAX	-5		5	
Negative Supply Current	I-	All channels on or off, VIN = 0V or 5V, V+ = 16.5V V- = -16.5V	TA = +25°C	-1	-0.0001	1	μA
			TA = TMIN to TMAX	-5		5	
Logic Supply Current	IL	All channels on or off, VIN = 0V or 5V, V+ = 16.5V V- = -16.5V	TA = +25°C	-1	0.0001	1	μA
			TA = TMIN to TMAX	-5		5	
Ground Current	IGND	All channels on or off, VIN = 0V or 5V, V+ = 16.5V V- = -16.5V	TA = +25°C	-1	-0.0001	1	μA
			TA = TMIN to TMAX	-5		5	
DYNAMIC							
Turn-On Time	t _{ON}	Figure 2, VCOM = ±10V	TA = +25°C	110	175	ns	
			TA = TMIN to TMAX		220		
Turn-Off Time	t _{OFF}	Figure 2, VCOM = ±10V	TA = +25°C	100	145	ns	
			TA = TMIN to TMAX		160		
Break-Before-Make Time Delay	t _D	MAX353 only, Figure 3, RL = 300Ω, CL = 35pF	TA = +25°C	25		ns	
Charge Injection	Q	CL = 1.0nF, VGEN = 0V, RGEN = 0Ω, Figure 4	TA = +25°C	5	10	pC	
Off Isolation (Note 6)	OIRR	RL = 50Ω, CL = 5pF, f = 1MHz, Figure 5	TA = +25°C	68		dB	
Crosstalk (Note 7)		RL = 50Ω, CL = 5pF, f = 1MHz, Figure 6	TA = +25°C	85		dB	
NC or NO Capacitance	C _(OFF)	f = 1MHz, Figure 7	TA = +25°C	9		pF	
COM Off Capacitance	C _(COM)	f = 1MHz, Figure 7	TA = +25°C	9		pF	
On Capacitance	C _(COM)	f = 1MHz, Figure 8	TA = +25°C	35		pF	

Precision, Quad, SPST Analog Switches

ELECTRICAL CHARACTERISTICS—Single Supply

(V+ = 12V, V- = 0V, VL = 5V, GND = 0V, VINH = 2.4V, VINL = 0.8V, TA = TMIN to TMAX, unless otherwise noted.)

PARAMETER	SYMBOL	CONDITIONS		MIN	TYP (Note 3)	MAX	UNITS
SWITCH							
Analog Signal Range	VCOM_, VNO_, VNC	(Notes 1, 4)		0		V+	V
Channel On Resistance	RON	I _{COM} = -10mA, V _{NC_} or V _{NO_} = 3.8V, V+ = 10.8V	TA = +25°C TA = TMIN to TMAX		40	80 100	Ω
SUPPLY							
Positive Supply Current	I+	V+ = 13.2V, all channels on or off, VIN = 0V or 5V	TA = +25°C TA = TMAX	-1	0.0001	1 5	μA
Negative Supply Current	I-	V+ = 13.2V, all channels on or off, VIN = 0V or 5V	TA = +25°C TA = TMAX	-1	0.0001	1 5	μA
Logic Supply Current	IL	VL = 5.25V, all channels on or off, VIN = 0V or 5V	TA = +25°C TA = TMAX	-1	0.0001	1 5	μA
Ground Current	IGND	VL = 5.25V, all channels on or off, VIN = 0V or 5V	TA = +25°C TA = TMAX	-1	-0.0001	1 5	μA
DYNAMIC							
Turn-On Time	tON	Figure 2, VNO_ or VNC_ = 8V	TA = +25°C TA = TMIN to TMAX		175	250 315	ns
Turn-Off Time	tOFF	Figure 2, VNO_ or VNC_ = 8V	TA = +25°C TA = TMIN to TMAX		95	125 140	ns
Break-Before-Make Time Delay	tD	MAX353 only, Figure 3, RL = 300Ω, CL = 35pF	TA = +25°C		25		ns
Charge Injection	Q	Figure 8, CL = 1.0nF, VGEN = 0V, RGEN = 0V	TA = +25°C		5	10	pC

Note 3: The algebraic convention, where the most negative value is a minimum and the most positive value a maximum, is used in this data sheet.

Note 4: Guaranteed by design.

Note 5: $\Delta R_{ON} = \Delta R_{ON\ max} - \Delta R_{ON\ min}$. On-resistance match between channels and flatness are guaranteed only with bipolar-supply operation.

Note 6: See Figure 5. Off Isolation = $20 \log_{10} [V_{COM} / (V_{NC\ or\ VNO})]$, V_{COM} = output, V_{NC} or V_{NO} = input to off switch.

Note 7: Between any two switches. See Figure 6.

Precision, Quad, SPST Analog Switches

Typical Operating Characteristics

($T_A = +25^\circ\text{C}$, unless otherwise noted.)

MAX3511/MAX352/MAX353

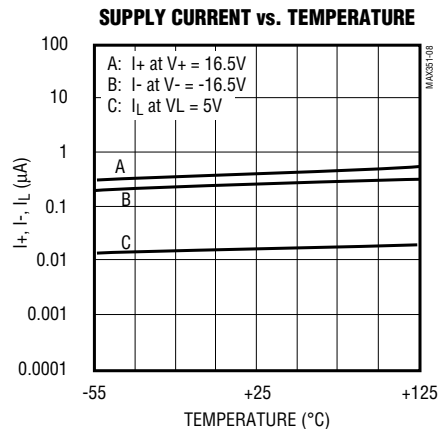
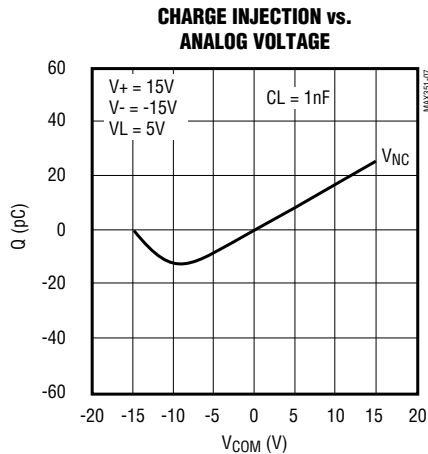
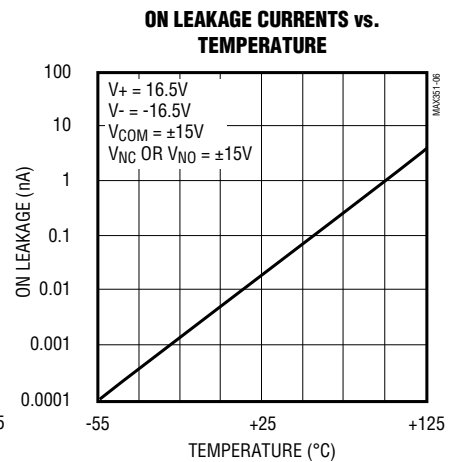
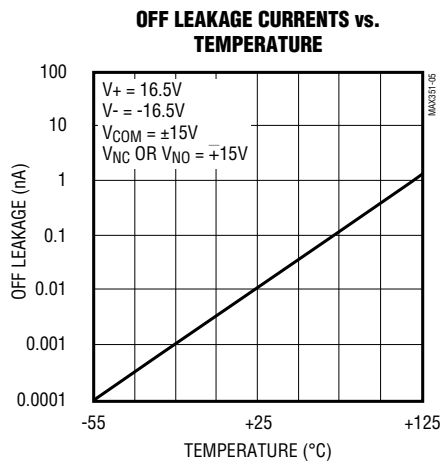
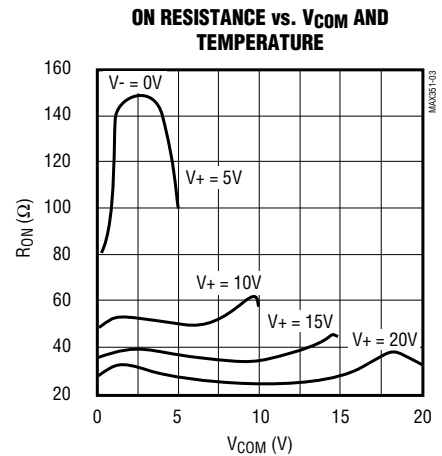

Precision, Quad, SPST Analog Switches

Pin Description

PIN		NAME	FUNCTION
DIP/SO	QFN		
1, 16, 9, 8	15, 14, 7, 6	IN1–N4	Logic Control Input
2, 15, 10, 7	16, 13, 8, 5	COM1–COM4	Analog Switch Common Terminal
3, 15, 11, 6	1, 12, 9, 4	NO or NC	Analog Switch NO or NC Terminal
4	2	V-	Negative-Supply Voltage Input
5	3	GND	Ground
12	10	V _L	Logic Supply Voltage
13	11	V+	Positive-Supply Voltage Input—Connected To Substrate

Applications Information

Operation with Supplies Other than $\pm 15\text{V}$

The main limitation of supply voltages other than $\pm 15\text{V}$ is reduced analog-signal range. The MAX351/MAX352/MAX353 operate with $\pm 5\text{V}$ to $\pm 20\text{V}$ bipolar supplies. The *Typical Operating Characteristics* graphs show typical on resistance (R_{ON}) for $\pm 15\text{V}$, $\pm 10\text{V}$, and $\pm 5\text{V}$ supplies. (Switching times increase by a factor of two or more for operation at $\pm 5\text{V}$.) The MAX351/MAX352/MAX353 can operate from $+10\text{V}$ to $+30\text{V}$ unipolar supplies. Each device can also be powered from unbalanced supplies such as $+24\text{V}$ and -5V . Connect V- to 0V when operating with a single supply. V_L must be connected to $+5\text{V}$ to be TTL compatible or to V+ for CMOS-logic input levels.

Overvoltage Protection

Proper power-supply sequencing is recommended for all CMOS devices. Do not exceed the absolute maximum ratings because stresses beyond the listed ratings may cause permanent damage to the devices. Always sequence V+ first, followed by V_L, V-, and logic inputs. If power-supply sequencing is not possible, add two small signal diodes in series with the supply pins for overvoltage protection (Figure 1). Adding diodes reduces the analog signal range to 1V below V+ and 1V below V-, but low switch resistance and low-leakage characteristics are unaffected. Device operation is unchanged, and the difference between V+ to V- should not exceed $+44\text{V}$.

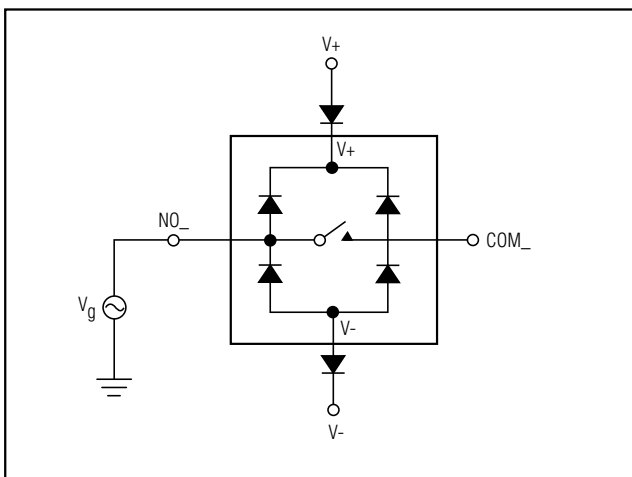

Figure 1. Overvoltage Protection Using External Blocking Diodes

Precision, Quad, SPST Analog Switches

Test Circuits/Timing Diagrams

MAX351/MAX352/MAX353

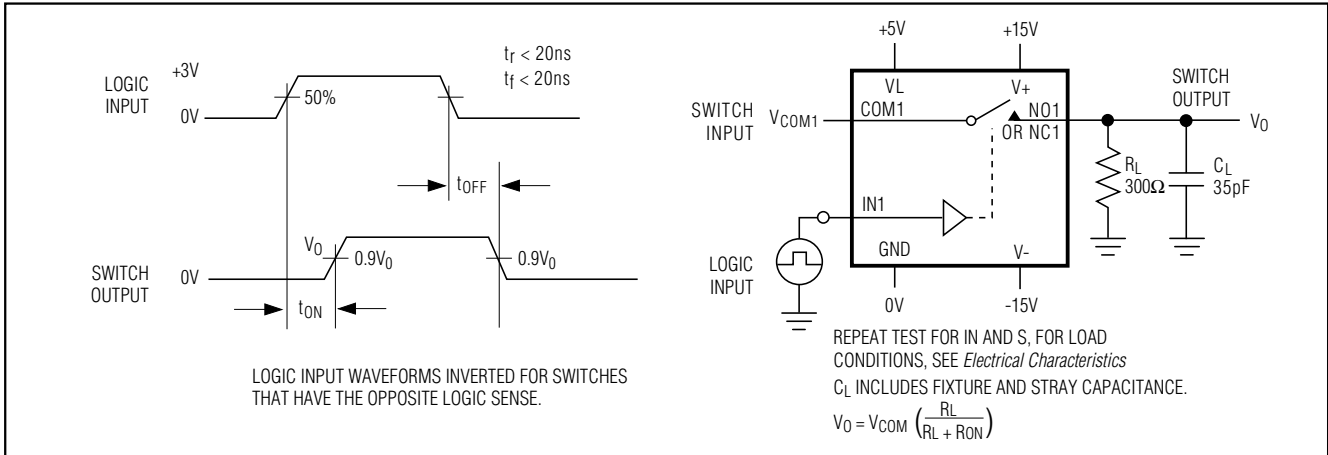

Figure 2. Switching-Time Test Circuit

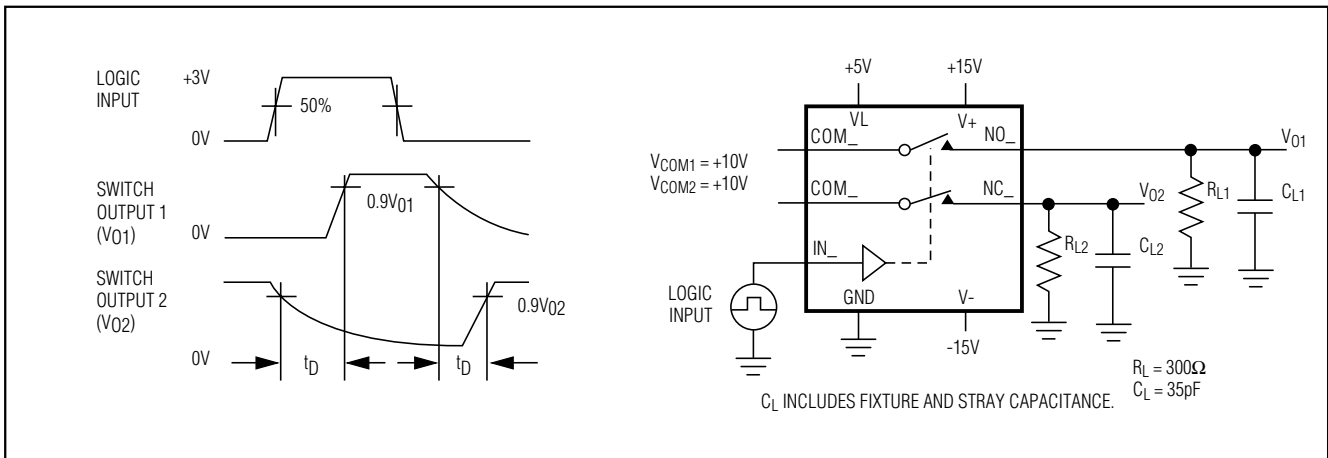

Figure 3. Break-Before-Make Test Circuit (MAX353 only)

Precision, Quad, SPST Analog Switches

Test Circuits/Timing Diagrams (continued)

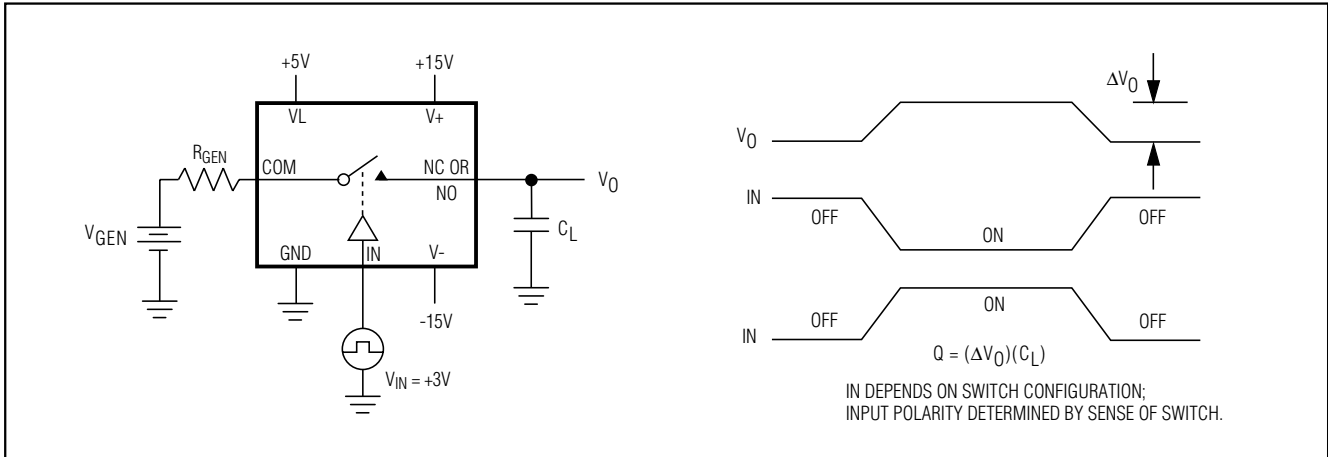

Figure 4. Charge-Injection Test Circuit

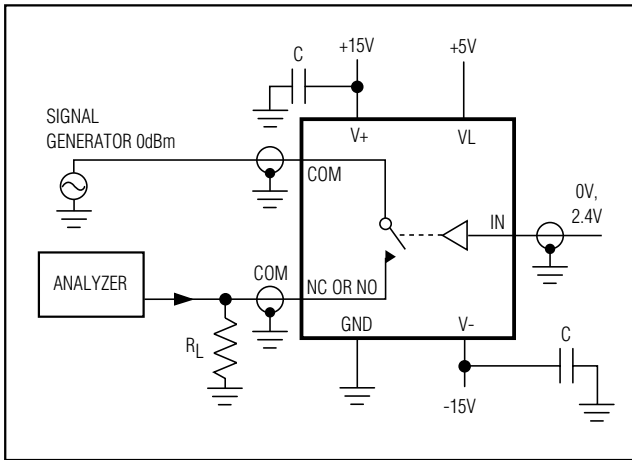

Figure 5. Off-Isolation Test Circuit

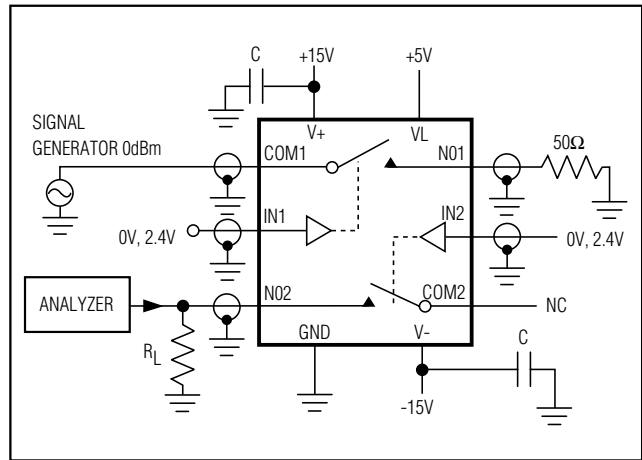

Figure 6. Crosstalk Test Circuit

Precision, Quad, SPST Analog Switches

Test Circuits/Timing Diagrams (continued)

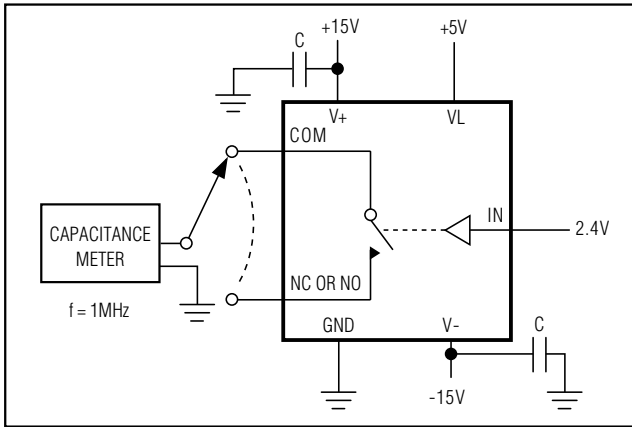

Figure 7. Channel-Off Capacitance

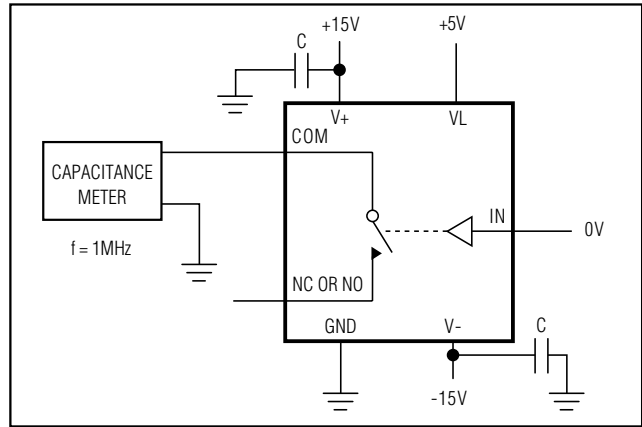
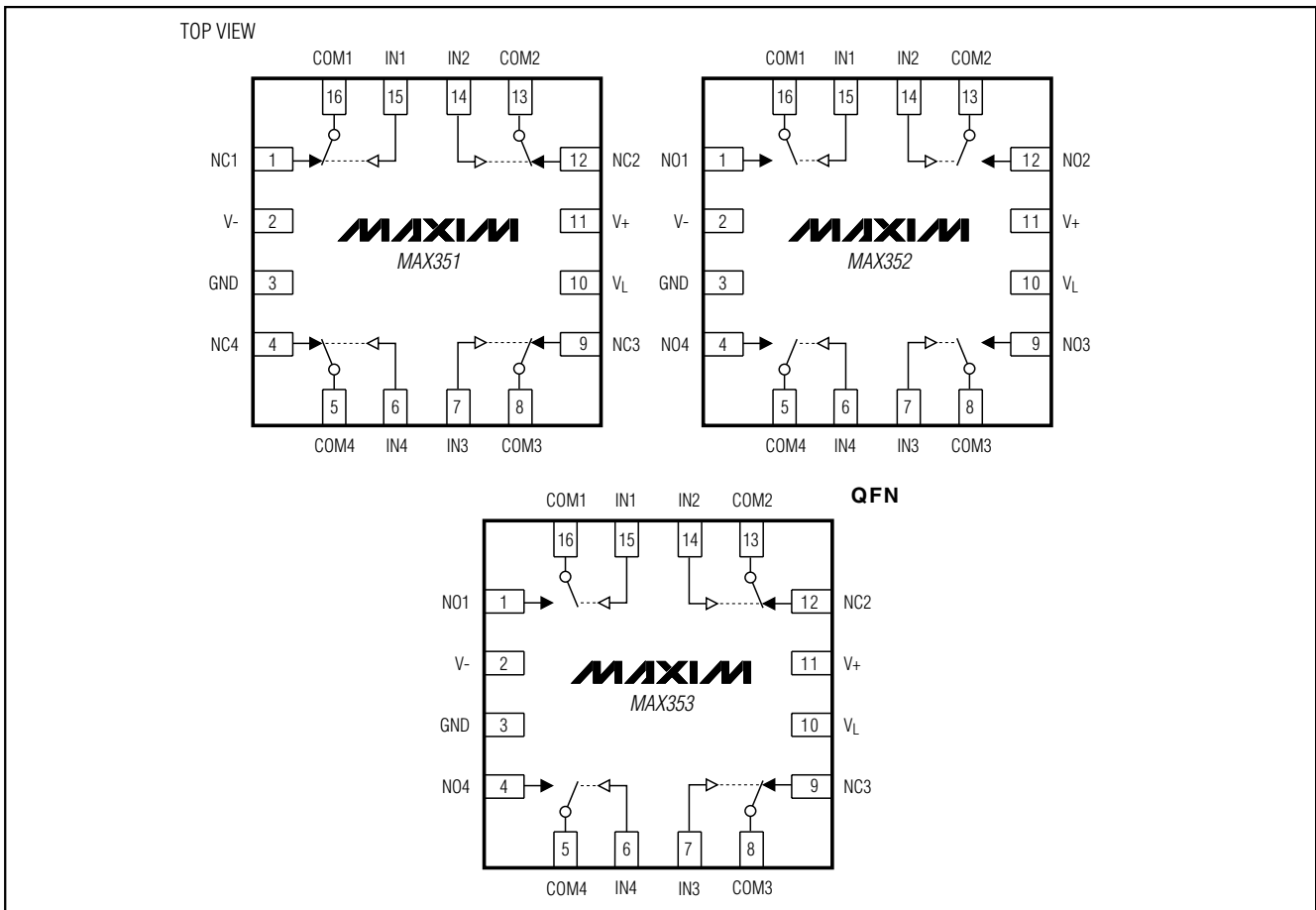

Figure 8. Channel-On Capacitance Test Circuit

Pin Configurations (continued)



MAX351/MAX352/MAX353

Precision, Quad, SPST Analog Switches

Ordering Information (continued)

PART	TEMP RANGE	PIN-PACKAGE
MAX352CPE	0°C to +70°C	16 Plastic DIP
MAX352CSE	0°C to +70°C	16 Narrow SO
MAX352C/D	0°C to +70°C	Dice*
MAX352EGE	-40°C to +85°C	16 QFN
MAX352EPE	-40°C to +85°C	16 Plastic DIP
MAX352ESE	-40°C to +85°C	16 Narrow SO
MAX352EJE	-40°C to +85°C	16 CERDIP
MAX352MJE	-55°C to +125°C	16 CERDIP
MAX353CPE	0°C to +70°C	16 Plastic DIP
MAX353CSE	0°C to +70°C	16 Narrow SO
MAX353C/D	0°C to +70°C	Dice*
MAX353EGE	-40°C to +85°C	16 QFN
MAX353EPE	-40°C to +85°C	16 Plastic DIP
MAX353ESE	-40°C to +85°C	16 Narrow SO
MAX353EJE	-40°C to +85°C	16 CERDIP
MAX353MJE	-55°C to +125°C	16 CERDIP

*Contact factory for availability and processing to MIL-STD-883.

Chip Topography

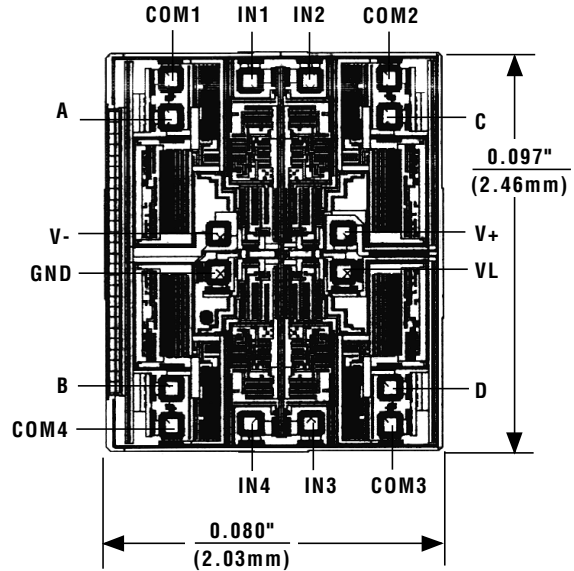

TRANSISTOR COUNT: 136
SUBSTRATE CONNECTED TO V+

MAX351		MAX352		MAX353	
PIN	NAME	PIN	NAME	PIN	NAME
A	NC	A	NO	A	NO
B	NC	B	NO	B	NO
C	NC	C	NO	C	NC
D	NC	D	NO	D	NC

Precision, Quad, SPST Analog Switches

Package Information

(The package drawing(s) in this data sheet may not reflect the most current specifications. For the latest package outline information, go to www.maxim-ic.com/packages.)

MAX351/MAX352/MAX353



Precision, Quad, SPST Analog Switches

Package Information (continued)

(The package drawing(s) in this data sheet may not reflect the most current specifications. For the latest package outline information, go to www.maxim-ic.com/packages.)



Precision, Quad, SPST Analog Switches

Package Information (continued)

(The package drawing(s) in this data sheet may not reflect the most current specifications. For the latest package outline information, go to www.maxim-ic.com/packages.)

MAX351/MAX352/MAX353



NOTES:

- DIE THICKNESS ALLOWABLE IS 0.305mm MAXIMUM (.012 INCHES MAXIMUM)
- DIMENSIONING & TOLERANCES CONFORM TO ASME Y14.5M - 1994.
- N IS THE NUMBER OF TERMINALS.
Nd IS THE NUMBER OF TERMINALS IN X-DIRECTION &
No IS THE NUMBER OF TERMINALS IN Y-DIRECTION.
- DIMENSION b APPLIES TO PLATED TERMINAL AND IS MEASURED BETWEEN 0.20 AND 0.25mm FROM TERMINAL TIP.
- THE PIN #1 IDENTIFIER MUST BE EXISTED ON THE TOP SURFACE OF THE PACKAGE BY USING INDENTATION MARK OR INK/ LASER MARKED.
- EXACT SHAPE AND SIZE OF THIS FEATURE IS OPTIONAL.
- ALL DIMENSIONS ARE IN MILLIMETERS.
- PACKAGE WARPAGE MAX 0.05mm.
- APPLIED FOR EXPOSED PAD AND TERMINALS.
EXCLUDE EMBEDDED PART OF EXPOSED PAD FROM MEASURING.
- MEETS JEDEC MO220.
- THIS PACKAGE OUTLINE APPLIES TO ANVIL SINGULATION (STEPPED SIDES) AND TO SAW SINGULATION (STRAIGHT SIDES) QFN STYLES.

COMMON DIMENSIONS				
	MIN.	NOM.	MAX.	
A	0.90	0.90	1.00	
A1	0.00	0.01	0.05	
A2	0.00	0.95	1.00	
A3	0.20 REF.			
D	5.00 BSC			
D1	4.75 BSC			
F	5.00 BSC			
E1	4.75 BSC			
B	0°	-	12°	
P	0	-	0.60	
D2	1.25	-	3.25	
E2	1.25	-	3.25	

PITCH VARIATION B				PITCH VARIATION B				PITCH VARIATION C				PITCH VARIATION D			
MIN.	NOM.	MAX.		MIN.	NOM.	MAX.		MIN.	NOM.	MAX.		MIN.	NOM.	MAX.	
0.80 BSC				0.65 BSC				0.50 BSC				0.50 BSC			
N	16	3 N		N	20	3 N		N	28	3 N		N	32	3 N	
Ind	4	3 Ind		Ind	5	3 Ind		Ind	7	3 Ind		Ind	8	3 Ind	
No	4	3 No		No	5	3 No		No	7	3 No		No	8	3 No	
L	0.35	0.55	0.75	L	0.35	0.55	0.75	L	0.35	0.55	0.75	L	0.30	0.40	0.50
b	0.28	0.33	0.40	b	0.23	0.28	0.35	b	0.18	0.23	0.30	b	0.18	0.23	0.30



MAXIMUM INFORMATION			
TITLE			
PACKAGE OUTLINE, 16,20,28,32L QFN, 5x5x0.90 MM			
APPROVAL	ISSUEMENT CONTROL NO.	REV.	DATE
	21-0091	G	2/2

Maxim cannot assume responsibility for use of any circuitry other than circuitry entirely embodied in a Maxim product. No circuit patent licenses are implied. Maxim reserves the right to change the circuitry and specifications without notice at any time.

Maxim Integrated Products, 120 San Gabriel Drive, Sunnyvale, CA 94086 408-737-7600 _____ 13

Looking for pricing, stock, or lifecycle information?

Click below to explore more details on WIN SOURCE:

-  [View MAX351ESE+ on WIN SOURCE](#)
-  [Maxim Integrated Information](#)

Optimize Your Supply Chain with WIN SOURCE Solutions

-  Global Sourcing Solution
-  Obsolete Management
-  Cost Control Management
-  Shortage Management
-  Alternative Solution
-  Excess Inventory Management