



THE DATASHEET OF MAX3491ESD+T



MAX3483/MAX3485/ MAX3486/MAX3488/ MAX3490/MAX3491

3.3V-Powered, 10Mbps and Slew-Rate-Limited True RS-485/RS-422 Transceivers

General Description

The MAX3483, MAX3485, MAX3486, MAX3488, MAX3490, and MAX3491 are 3.3V, low-power transceivers for RS-485 and RS-422 communication. Each part contains one driver and one receiver. The MAX3483 and MAX3488 feature slew-rate-limited drivers that minimize EMI and reduce reflections caused by improperly terminated cables, allowing error-free data transmission at data rates up to 250kbps. The partially slew-rate-limited MAX3486 transmits up to 2.5Mbps. The MAX3485, MAX3490, and MAX3491 transmit at up to 10Mbps.

Drivers are short-circuit current-limited and are protected against excessive power dissipation by thermal shutdown circuitry that places the driver outputs into a high-impedance state. The receiver input has a fail-safe feature that guarantees a logic-high output if both inputs are open circuit.

The MAX3488, MAX3490, and MAX3491 feature full-duplex communication, while the MAX3483, MAX3485, and MAX3486 are designed for half-duplex communication.

Applications

- Low-Power RS-485/RS-422 Transceivers
- Telecommunications
- Transceivers for EMI-Sensitive Applications
- Industrial-Control Local Area Networks

Features

- Operate from a Single 3.3V Supply—No Charge Pump!
- Interoperable with +5V Logic
- 8ns Max Skew (MAX3485/MAX3490/MAX3491)
- Slew-Rate Limited for Errorless Data Transmission (MAX3483/MAX3488)
- 2nA Low-Current Shutdown Mode (MAX3483/MAX3485/MAX3486/MAX3491)
- -7V to +12V Common-Mode Input Voltage Range
- Allows up to 32 Transceivers on the Bus
- Full-Duplex and Half-Duplex Versions Available
- Industry Standard 75176 Pinout (MAX3483/MAX3485/MAX3486)
- Current-Limiting and Thermal Shutdown for Driver Overload Protection

Ordering Information

| PART | TEMP. RANGE | PIN-PACKAGE |
|--------------------|----------------|---------------|
| MAX3483 CPA | 0°C to +70°C | 8 Plastic DIP |
| MAX3483CSA | 0°C to +70°C | 8 SO |
| MAX3483C/D | 0°C to +70°C | Dice* |
| MAX3483EPA | -40°C to +85°C | 8 Plastic DIP |
| MAX3483ESA | -40°C to +85°C | 8 SO |
| MAX3485 CPA | 0°C to +70°C | 8 Plastic DIP |
| MAX3485CSA | 0°C to +70°C | 8 SO |
| MAX3485C/D | 0°C to +70°C | Dice* |
| MAX3485EPA | -40°C to +85°C | 8 Plastic DIP |
| MAX3485ESA | -40°C to +85°C | 8 SO |

Ordering Information continued at end of data sheet.

* Contact factory for dice specifications.

Selection Table

| PART NUMBER | GUARANTEED DATA RATE (Mbps) | SUPPLY VOLTAGE (V) | HALF/FULL DUPLEX | SLEW-RATE LIMITED | DRIVER/RECEIVER ENABLE | SHUTDOWN CURRENT (nA) | PIN COUNT |
|----------------|-----------------------------|--------------------|------------------|-------------------|------------------------|-----------------------|-----------|
| MAX3483 | 0.25 | 3.0 to 3.6 | Half | Yes | Yes | 2 | 8 |
| MAX3485 | 10 | | Half | No | No | 2 | 8 |
| MAX3486 | 2.5 | | Half | Yes | Yes | 2 | 8 |
| MAX3488 | 0.25 | | Half | Yes | Yes | — | 8 |
| MAX3490 | 10 | | Half | No | No | — | 8 |
| MAX3491 | 10 | | Half | No | No | Yes | 2 |

MAX3483/MAX3485/
 MAX3486/MAX3488/
 MAX3490/MAX3491

3.3V-Powered, 10Mbps and Slew-Rate-Limited
 True RS-485/RS-422 Transceivers

Absolute Maximum Ratings

| | | | |
|---|-----------------------------------|---|-----------------|
| Supply Voltage (VCC) | 7V | 14-Pin Plastic DIP (derate 10mW/°C above +70°C) ... | 800mW |
| Control Input Voltage (RE, DE) | -0.3V to 7V | 14-Pin SO (derate 8.33mW/°C above +70°C) | 667mW |
| Driver Input Voltage (DI) | -0.3V to 7V | Operating Temperature Ranges | |
| Driver Output Voltage (A, B, Y, Z) | -7.5V to 12.5V | MAX34__C_ | 0°C to +70°C |
| Receiver Input Voltage (A, B) | -7.5V to 12.5V | MAX34__E_ | -40°C to +85°C |
| Receiver Output Voltage (RO) | -0.3V to (V _{CC} + 0.3V) | Junction Temperature | +160°C |
| Continuous Power Dissipation (T _A = +70°C) | | Storage Temperature Range | -65°C to +160°C |
| 8-Pin Plastic DIP (derate 9.09mW/°C above +70°C) .. | 727mW | Lead Temperature (soldering, 10sec) | +300°C |
| 8-Pin SO (derate 5.88mW/°C above +70°C) | 471mW | | |

Package Information

14 SOIC

| PACKAGE CODE | S14+1 |
|--|-------------------------|
| Outline Number | 21-0041 |
| Land Pattern Number | 90-0112 |
| Thermal Resistance, Single-Layer Board: | |
| Junction to Ambient (θ _{JA}) | 120 |
| Junction to Case (θ _{JA}) | 37 |
| Thermal Resistance, Four-Layer Board: | |
| Junction to Ambient (θ _{JA}) | 84 |
| Junction to Case (θ _{JA}) | 34 |

For the latest package outline information and land patterns (footprints), go to www.maximintegrated.com/packages. Note that a "+", "#", or "-" in the package code indicates RoHS status only. Package drawings may show a different suffix character, but the drawing pertains to the package regardless of RoHS status.

Package thermal resistances were obtained using the method described in JEDEC specification JESD51-7, using a four-layer board. For detailed information on package thermal considerations, refer to www.maximintegrated.com/thermal-tutorial.

MAX3483/MAX3485/
MAX3486/MAX3488/
MAX3490/MAX3491

3.3V-Powered, 10Mbps and Slew-Rate-Limited
True RS-485/RS-422 Transceivers

DC Electrical Characteristics

($V_{CC} = 3.3V \pm 0.3V$, $T_A = T_{MIN}$ to T_{MAX} , unless otherwise noted. Typical values are at $T_A = +25^\circ C$)

| PARAMETER | SYMBOL | CONDITIONS | | MIN | TYP | MAX | UNITS |
|--|-----------------|---|--|----------------|-------|----------|------------|
| Differential Driver Output | V_{OD} | $R_L = 100\Omega$ (RS-422), Figure 4 | | 2.0 | | | V |
| | | $R_L = 54\Omega$ (RS-485), Figure 4 | | 1.5 | | | |
| | | $R_L = 60\Omega$ (RS-485), $V_{CC} = 3.3V$, Figure 5 | | 1.5 | | | |
| Change in Magnitude of Driver Differential Output Voltage for Complementary Output States (Note 1) | ΔV_{OD} | $R_L = 54\Omega$ or 100Ω , Figure 4 | | | | 0.2 | V |
| Driver Common-Mode Output Voltage | V_{OC} | $R_L = 54\Omega$ or 100Ω , Figure 4 | | | | 3 | V |
| Change in Magnitude of Common-Mode Output Voltage (Note 1) | ΔV_{OC} | $R_L = 54\Omega$ or 100Ω , Figure 4 | | | | 0.2 | V |
| Input High Voltage | V_{IH} | DE, DI, RE | | 2.0 | | | V |
| Input Low Voltage | V_{IL} | DE, DI, RE | | | | 0.8 | V |
| Logic Input Current | I_{IN1} | DE, DI, RE | | | | ± 2 | μA |
| Input Current (A, B) | I_{IN2} | DE = 0V, $V_{CC} = 0V$ or $3.6V$ | $V_{IN} = 12V$ | | | 1.0 | mA |
| | | | $V_{IN} = -7V$ | | | -0.8 | |
| Output Leakage (Y, Z) | I_O | DE = 0V, RE = 0V, $V_{CC} = 0V$ or $3.6V$, MAX3491 | $V_{OUT} = 12V$ | | | 20 | μA |
| | | | $V_{OUT} = -7V$ | | | -20 | |
| Output Leakage (Y, Z) in Shutdown Mode | I_O | DE = 0V, RE = V_{CC} , $V_{CC} = 0V$ or $3.6V$, MAX3491 | $V_{OUT} = 12V$ | | | 1 | μA |
| | | | $V_{OUT} = -7V$ | | | -1 | |
| Receiver Differential Threshold Voltage | V_{TH} | $-7V \leq V_{CM} \leq 12V$ | | -0.2 | | 0.2 | V |
| Receiver Input Hysteresis | ΔV_{TH} | $V_{CM} = 0V$ | | | 50 | | mV |
| Receiver Output High Voltage | V_{OH} | $I_{OUT} = -1.5mA$, $V_{ID} = 200mV$, Figure 6 | | $V_{CC} - 0.4$ | | | V |
| Receiver Output Low Voltage | V_{OL} | $I_{OUT} = 2.5mA$, $V_{ID} = 200mV$, Figure 6 | | | | 0.4 | V |
| Three-State (High Impedance) Output Current at Receiver | I_{OZR} | $V_{CC} = 3.6V$, $0V \leq V_{OUT} \leq V_{CC}$ | | | | ± 1 | μA |
| Receiver Input Resistance | R_{IN} | $-7V \leq V_{CM} \leq 12V$ | | 12 | | | k Ω |
| Supply Current | I_{CC} | No load, DI = 0V or V_{CC} | DE = V_{CC} , RE = 0V or V_{CC} | | 1.1 | 2.2 | mA |
| | | | DE = 0V, RE = 0V | | 0.95 | 1.9 | |
| Supply Current in Shutdown Mode | I_{SHDN} | DE = 0V, RE = V_{CC} , DI = V_{CC} or 0V | | | 0.002 | 1 | μA |
| Driver Short-Circuit Output Current | I_{OSD} | $V_{OUT} = -7V$ | | | | -250 | mA |
| | | $V_{OUT} = 12V$ | | | | 250 | |
| Receiver Short-Circuit Output Current | I_{OSR} | $0V \leq V_{RO} \leq V_{CC}$ | | ± 8 | | ± 60 | mA |

MAX3483/MAX3485/
MAX3486/MAX3488/
MAX3490/MAX3491

3.3V-Powered, 10Mbps and Slew-Rate-Limited
True RS-485/RS-422 Transceivers

Driver Switching Characteristics—MAX3485, MAX3490, and MAX3491

($V_{CC} = 3.3V$, $T_A = +25^\circ C$)

| PARAMETER | SYMBOL | CONDITIONS | MIN | TYP | MAX | UNITS |
|--|-----------|-------------------------------|-----|-----|-----|-------|
| Driver Differential Output Delay | t_{DD} | $R_L = 60\Omega$, Figure 7 | 1 | 22 | 35 | ns |
| Driver Differential Output Transition Time | t_{TD} | $R_L = 60\Omega$, Figure 7 | 3 | 8 | 25 | ns |
| Driver Propagation Delay, Low-to-High Level | t_{PLH} | $R_L = 27\Omega$, Figure 8 | 7 | 22 | 35 | ns |
| Driver Propagation Delay, High-to-Low Level | t_{PHL} | $R_L = 27\Omega$, Figure 8 | 7 | 22 | 35 | ns |
| $ t_{PLH} - t_{PHL} $ Driver Propagation Delay Skew (Note 2) | t_{PDS} | $R_L = 27\Omega$, Figure 8 | | | 8 | ns |
| DRIVER OUTPUT ENABLE/DISABLE TIMES (MAX3485/MAX3491 only) | | | | | | |
| Driver Output Enable Time to Low Level | t_{PZL} | $R_L = 110\Omega$, Figure 10 | | 45 | 90 | ns |
| Driver Output Enable Time to High Level | t_{PZH} | $R_L = 110\Omega$, Figure 9 | | 45 | 90 | ns |
| Driver Output Disable Time from High Level | t_{PHZ} | $R_L = 110\Omega$, Figure 9 | | 40 | 80 | ns |
| Driver Output Disable Time from Low Level | t_{PLZ} | $R_L = 110\Omega$, Figure 10 | | 40 | 80 | ns |
| Driver Output Enable Time from Shutdown to Low Level | t_{PSL} | $R_L = 110\Omega$, Figure 10 | | 650 | 900 | ns |
| Driver Output Enable Time from Shutdown to High Level | t_{PSH} | $R_L = 110\Omega$, Figure 9 | | 650 | 900 | ns |

Driver Switching Characteristics—MAX3486

($V_{CC} = 3.3V$, $T_A = +25^\circ C$)

| PARAMETER | SYMBOL | CONDITIONS | MIN | TYP | MAX | UNITS |
|--|-----------|-------------------------------|-----|-----|------|-------|
| Driver Differential Output Delay | t_{DD} | $R_L = 60\Omega$, Figure 7 | 24 | 48 | 70 | ns |
| Driver Differential Output Transition Time | t_{TD} | $R_L = 60\Omega$, Figure 7 | 15 | 35 | 60 | ns |
| Driver Propagation Delay, Low-to-High Level | t_{PLH} | $R_L = 27\Omega$, Figure 8 | 20 | 48 | 70 | ns |
| Driver Propagation Delay, High-to-Low Level | t_{PHL} | $R_L = 27\Omega$, Figure 8 | 20 | 48 | 70 | ns |
| $ t_{PLH} - t_{PHL} $ Driver Propagation Delay Skew (Note 2) | t_{PDS} | $R_L = 27\Omega$, Figure 8 | | | 11 | ns |
| Driver Output Enable Time to Low Level | t_{PZL} | $R_L = 110\Omega$, Figure 10 | | 55 | 100 | ns |
| Driver Output Enable Time to High Level | t_{PZH} | $R_L = 110\Omega$, Figure 9 | | 55 | 100 | ns |
| Driver Output Disable Time from High Level | t_{PHZ} | $R_L = 110\Omega$, Figure 9 | | 45 | 80 | ns |
| Driver Output Disable Time from Low Level | t_{PLZ} | $R_L = 110\Omega$, Figure 10 | | 45 | 80 | ns |
| Driver Output Enable Time from Shutdown to Low Level | t_{PSL} | $R_L = 110\Omega$, Figure 10 | | 700 | 1000 | ns |
| Driver Output Enable Time from Shutdown to High Level | t_{PSH} | $R_L = 110\Omega$, Figure 9 | | 700 | 1000 | ns |

MAX3483/MAX3485/
MAX3486/MAX3488/
MAX3490/MAX3491

3.3V-Powered, 10Mbps and Slew-Rate-Limited
True RS-485/RS-422 Transceivers

Driver Switching Characteristics—MAX3483 and MAX3488

($V_{CC} = 3.3V$, $T_A = +25^\circ C$)

| PARAMETER | SYMBOL | CONDITIONS | MIN | TYP | MAX | UNITS |
|--|-----------|-------------------------------|-----|------|------|-------|
| Driver Differential Output Delay | t_{DD} | $R_L = 60\Omega$, Figure 7 | 600 | 900 | 1400 | ns |
| Driver Differential Output Transition Time | t_{TD} | $R_L = 60\Omega$, Figure 7 | 400 | 700 | 1200 | ns |
| Driver Propagation Delay, Low-to-High Level | t_{PLH} | $R_L = 27\Omega$, Figure 8 | 700 | 1000 | 1500 | ns |
| Driver Propagation Delay, High-to-Low Level | t_{PHL} | $R_L = 27\Omega$, Figure 8 | 700 | 1000 | 1500 | ns |
| $ t_{PLH} - t_{PHL} $ Driver Propagation Delay Skew (Note 2) | t_{PDS} | $R_L = 27\Omega$, Figure 8 | | 100 | | ns |
| DRIVER OUTPUT ENABLE/DISABLE TIMES (MAX3485/MAX3491 only) | | | | | | |
| Driver Output Enable Time to Low Level | t_{PZL} | $R_L = 110\Omega$, Figure 10 | | 900 | 1300 | ns |
| Driver Output Enable Time to High Level | t_{PZH} | $R_L = 110\Omega$, Figure 9 | | 600 | 800 | ns |
| Driver Output Disable Time from High Level | t_{PHZ} | $R_L = 110\Omega$, Figure 9 | | 50 | 80 | ns |
| Driver Output Disable Time from Low Level | t_{PLZ} | $R_L = 110\Omega$, Figure 10 | | 50 | 80 | ns |
| Driver Output Enable Time from Shutdown to Low Level | t_{PSL} | $R_L = 110\Omega$, Figure 10 | | 1.9 | 2.7 | ns |
| Driver Output Enable Time from Shutdown to High Level | t_{PSH} | $R_L = 110\Omega$, Figure 9 | | 2.2 | 3.0 | ns |

Receiver Switching Characteristics

($V_{CC} = 3.3V$, $T_A = +25^\circ C$)

| PARAMETER | SYMBOL | CONDITIONS | MIN | TYP | MAX | UNITS |
|---|------------|--|-----|-----|------|-------|
| Time to Shutdown | t_{SHDN} | MAX3483/MAX3485/MAX3486/MAX3491 only (Note 3) | 80 | 190 | 300 | ns |
| Receiver Propagation Delay, Low-to-High Level | t_{RPLH} | $V_{ID} = 0V$ to $3.0V$, $C_L = 15pF$, Figure 11 | 25 | 65 | 90 | ns |
| | | MAX3483/MAX3488 | 25 | 75 | 120 | |
| Receiver Propagation Delay, High-to-Low Level | t_{RPHL} | $V_{ID} = 0V$ to $3.0V$, $C_L = 15pF$, Figure 11 | 25 | 65 | 90 | ns |
| | | MAX3483/MAX3488 | 25 | 75 | 120 | |
| $ t_{PLH} - t_{PHL} $ Receiver Propagation Delay Skew | t_{RPDS} | $V_{ID} = 0V$ to $3.0V$, $C_L = 15pF$, Figure 11 | | | 10 | ns |
| | | MAX3483/MAX3488 | | | 20 | |
| Receiver Output Enable Time to Low Level | t_{PRZL} | $C_L = 15pF$, Figure 12, MAX3483/MAX3485/MAX3486/MAX3491 only | | 25 | 50 | ns |
| Receiver Output Enable Time to High Level | t_{PRZH} | $C_L = 15pF$, Figure 12, MAX3483/MAX3485/MAX3486/MAX3491 only | | 25 | 50 | ns |
| Receiver Output Disable Time from High Level | t_{PRHZ} | $C_L = 15pF$, Figure 12, MAX3483/MAX3485/MAX3486/MAX3491 only | | 25 | 45 | ns |
| Receiver Output Disable Time from Low Level | t_{PRLZ} | $C_L = 15pF$, Figure 12, MAX3483/MAX3485/MAX3486/MAX3491 only | | 25 | 45 | ns |
| Receiver Output Enable Time from Shutdown to Low Level | t_{PRSL} | $C_L = 15pF$, Figure 12, MAX3483/MAX3485/MAX3486/MAX3491 only | | 720 | 1400 | ns |
| Receiver Output Enable Time from Shutdown to High Level | t_{PRSH} | $C_L = 15pF$, Figure 12, MAX3483/MAX3485/MAX3486/MAX3491 only | | 720 | 1400 | ns |

Note 1: ΔV_{OD} and ΔV_{OC} are the changes in V_{OD} and V_{OC} , respectively, when the DI input changes state.

Note 2: Measured on $|t_{PLH}(Y) - t_{PHL}(Y)|$ and $|t_{PLH}(Z) - t_{PHL}(Z)|$.

Note 3: The transceivers are put into shutdown by bringing RE high and DE low. If the inputs are in this state for less than 80ns, the parts are guaranteed not to enter shutdown. If the inputs are in this state for at least 300ns, the parts are guaranteed to have entered shutdown. See *Low-Power Shutdown Mode* section.

MAX3483/MAX3485/
MAX3486/MAX3488/
MAX3490/MAX3491

3.3V-Powered, 10Mbps and Slew-Rate-Limited
True RS-485/RS-422 Transceivers

Typical Operating Characteristics

($V_{CC} = 3.3V$, $T_A = +25^\circ C$, unless otherwise noted.)

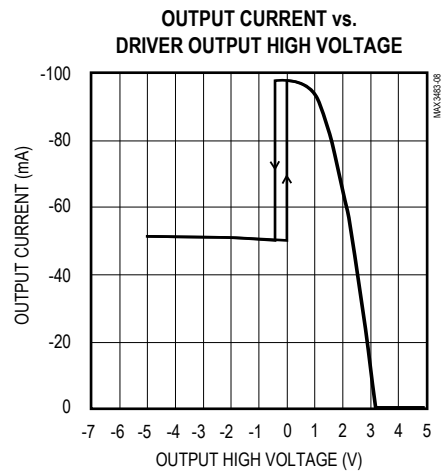
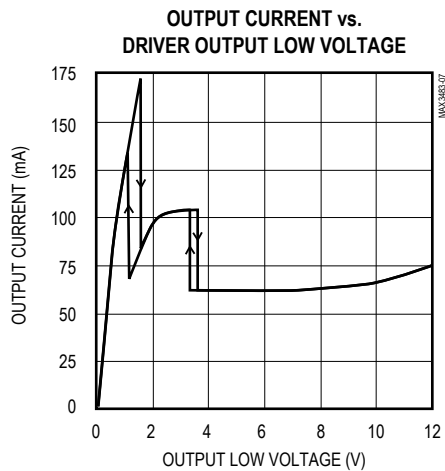
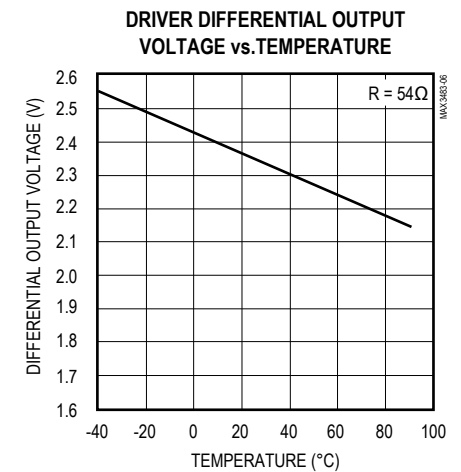
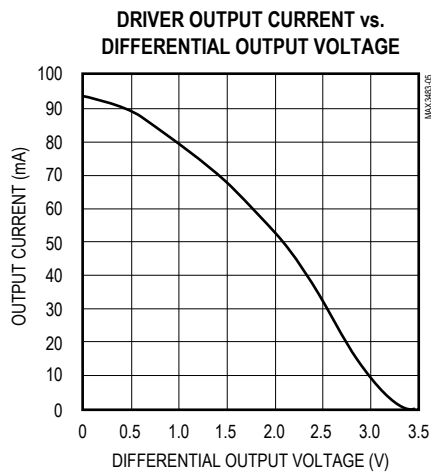
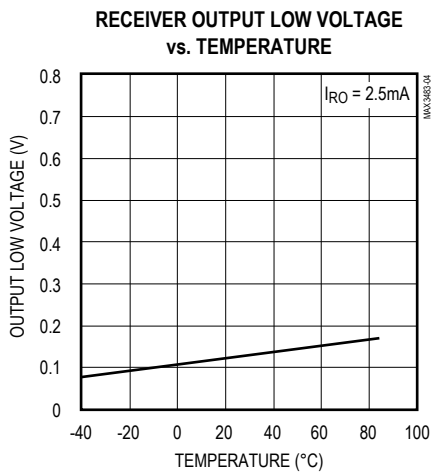
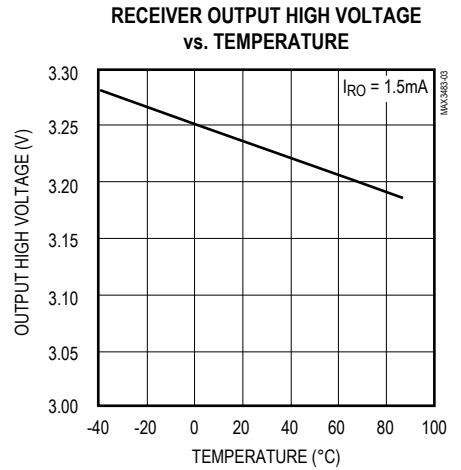
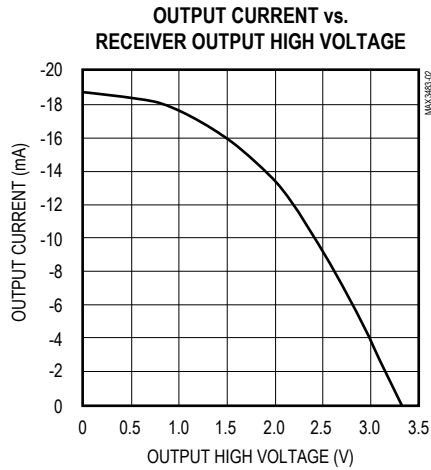
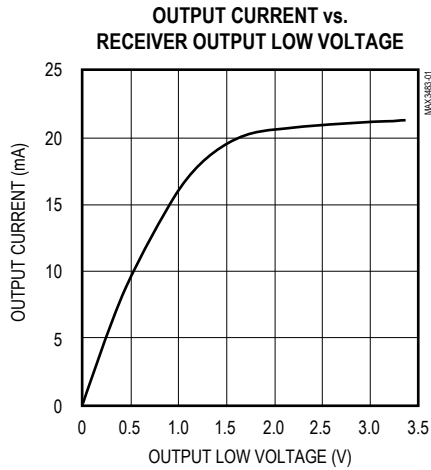

MAX3483/MAX3485/
MAX3486/MAX3488/
MAX3490/MAX3491

3.3V-Powered, 10Mbps and Slew-Rate-Limited
True RS-485/RS-422 Transceivers

Typical Operating Characteristics (continued)

($V_{CC} = 3.3V$, $T_A = +25^\circ C$, unless otherwise noted.)



Pin Description

| PIN | | | NAME | FUNCTION |
|---------------------------------|---------------------|---------|-----------------|---|
| MAX3483/ MAX3485/ MAX3486 | MAX3488/ MAX3490 | MAX3491 | | |
| 1 | 2 | 2 | RO | Receiver Output. If A > B by 200mV, RO will be high; if A < B by 200mV, RO will be low. |
| 2 | — | 3 | \overline{RE} | Receiver Output Enable. RO is enabled when \overline{RE} is low; RO is high impedance when \overline{RE} is high. If \overline{RE} is high and DE is low, the device will enter a low-power shutdown mode. |
| 3 | — | 4 | DE | Driver Output Enable. The driver outputs are enabled by bringing DE high. They are high impedance when DE is low. If \overline{RE} is high and DE is low, the device will enter a low-power shutdown mode. If the driver outputs are enabled, the parts function as line drivers. While they are high impedance, they function as line receivers if \overline{RE} is low. |
| 4 | 3 | 5 | DI | Driver Input. A low on DI forces output Y low and output Z high. Similarly, a high on DI forces output Y high and output Z low. |
| 5 | 4 | 6, 7 | GND | Ground |
| — | 5 | 9 | Y | Noninverting Driver Output |
| — | 6 | 10 | Z | Inverting Driver Output |
| 6 | — | — | A | Noninverting Receiver Input and Noninverting Driver Output |
| — | 8 | 12 | A | Noninverting Receiver Input |
| 7 | — | — | B | Inverting Receiver Input and Inverting Driver Output |
| — | 7 | 11 | B | Inverting Receiver Input |
| 8 | 1 | 13, 14 | V_{CC} | Positive Supply: $3.0V \leq V_{CC} \leq 3.6V$ |
| — | — | 1, 8 | N.C. | No Connect—not internally connected |

MAX3483/MAX3485/
MAX3486/MAX3488/
MAX3490/MAX3491

3.3V-Powered, 10Mbps and Slew-Rate-Limited
True RS-485/RS-422 Transceivers

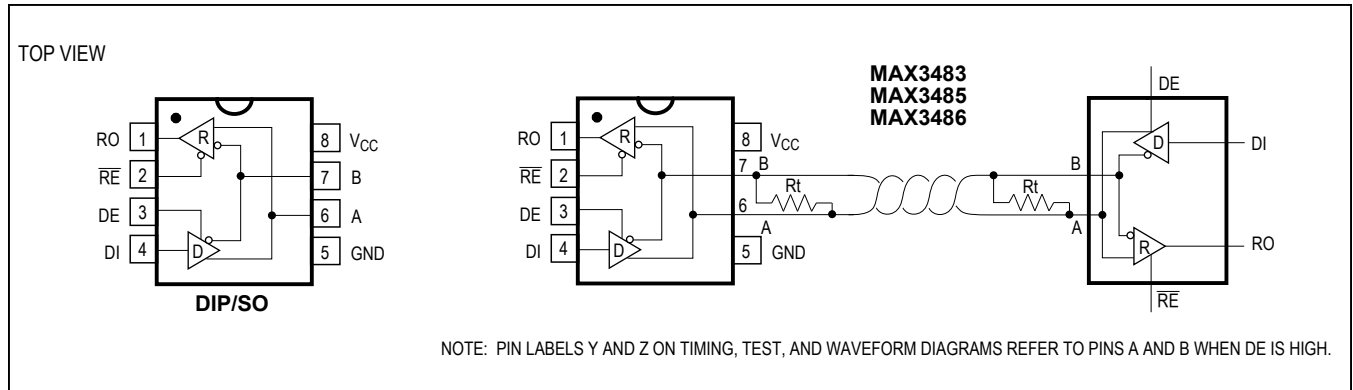

Figure 1. MAX3483/MAX3485/MAX3486 Pin Configuration and Typical Operating Circuit

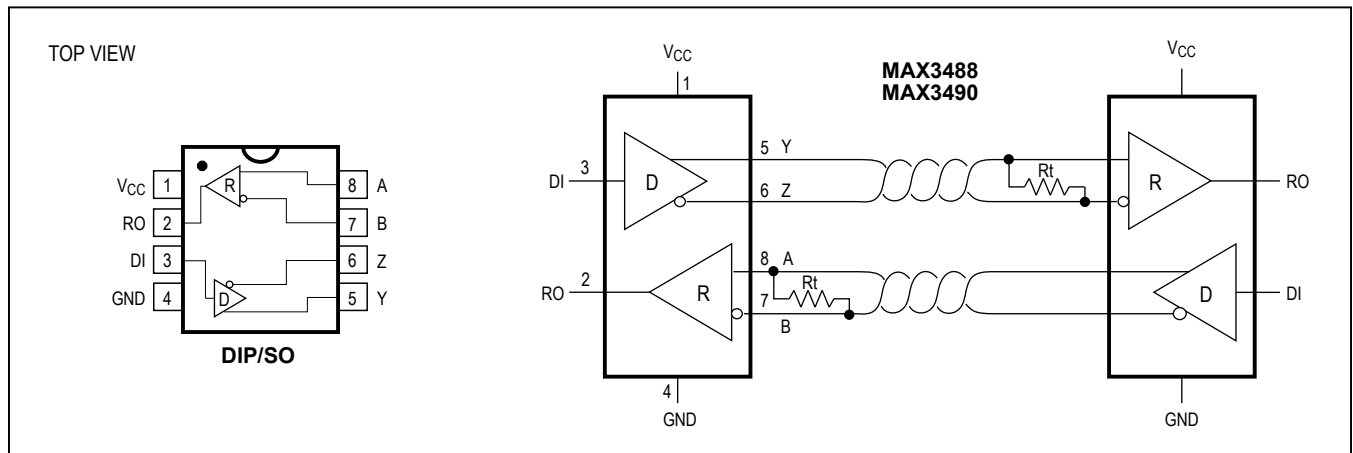

Figure 2. MAX3488/MAX3490 Pin Configuration and Typical Operating Circuit

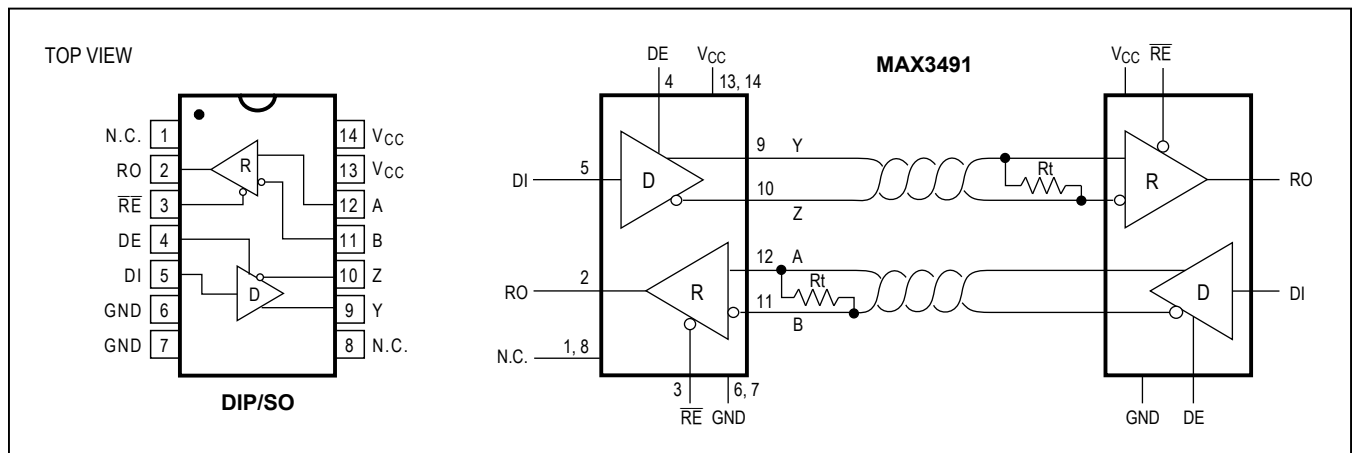

Figure 3. MAX3491 Pin Configuration and Typical Operating Circuit

MAX3483/MAX3485/
 MAX3486/MAX3488/
 MAX3490/MAX3491

3.3V-Powered, 10Mbps and Slew-Rate-Limited
 True RS-485/RS-422 Transceivers



Figure 4. Driver V_{OD} and V_{OC}



Figure 5. Driver V_{OD} with Varying Common-Mode Voltage



Figure 6. Receiver V_{OH} and V_{OL}



Figure 7. Driver Differential Output Delay and Transition Times

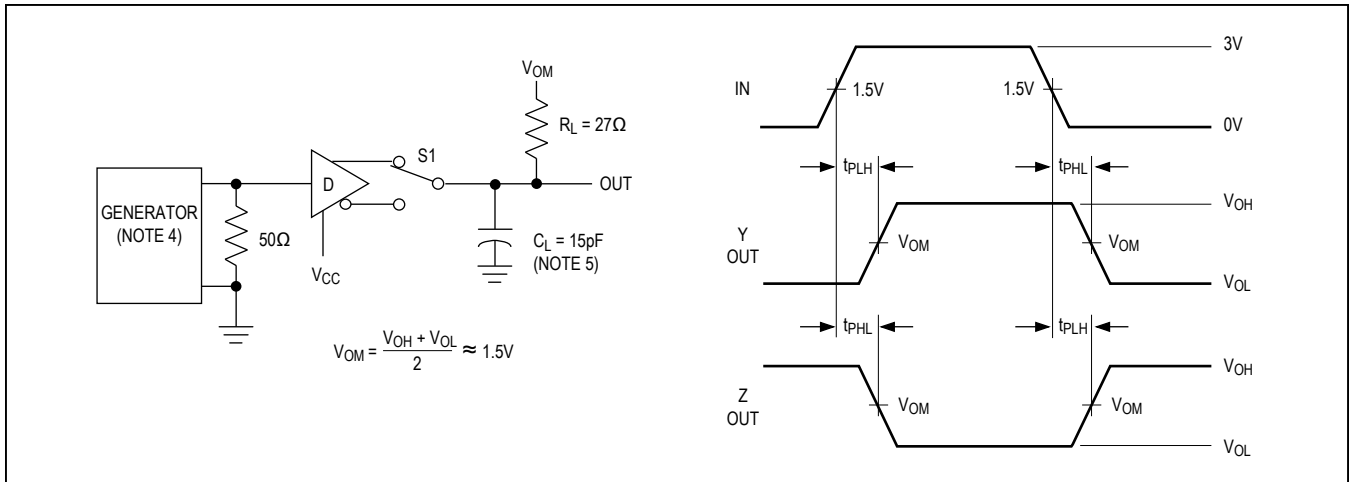

Figure 8. Driver Propagation Times

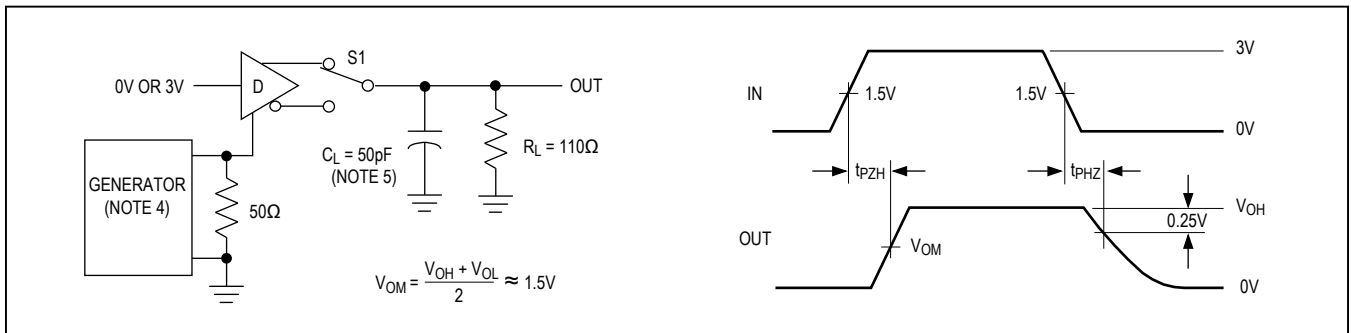

Figure 9. Driver Enable and Disable Times (t_{PZH} , t_{PSH} , t_{PHZ})

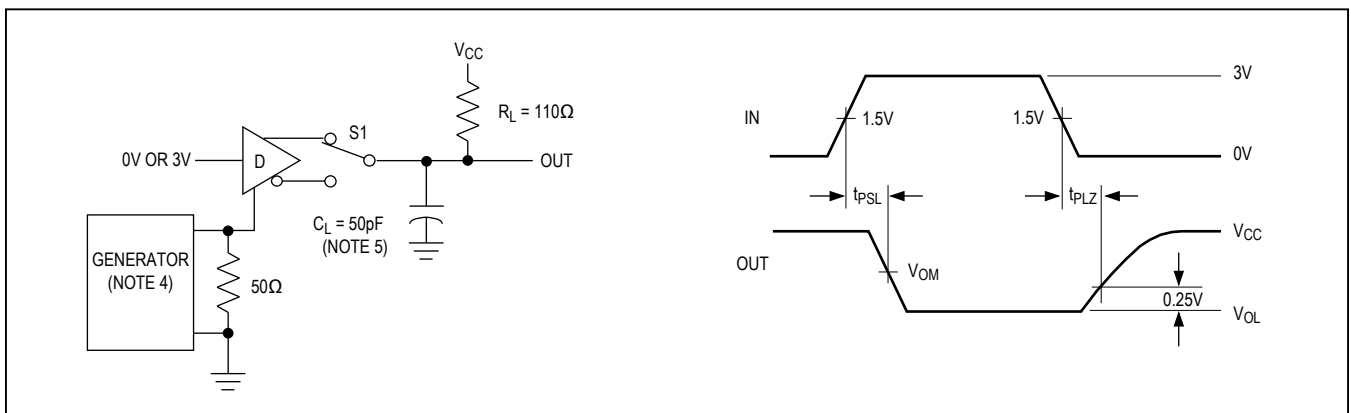

Figure 10. Driver Enable and Disable Times (t_{PZL} , t_{PSL} , t_{PLZ})

MAX3483/MAX3485/
MAX3486/MAX3488/
MAX3490/MAX3491

3.3V-Powered, 10Mbps and Slew-Rate-Limited
True RS-485/RS-422 Transceivers



Figure 11. Receiver Propagation Delay

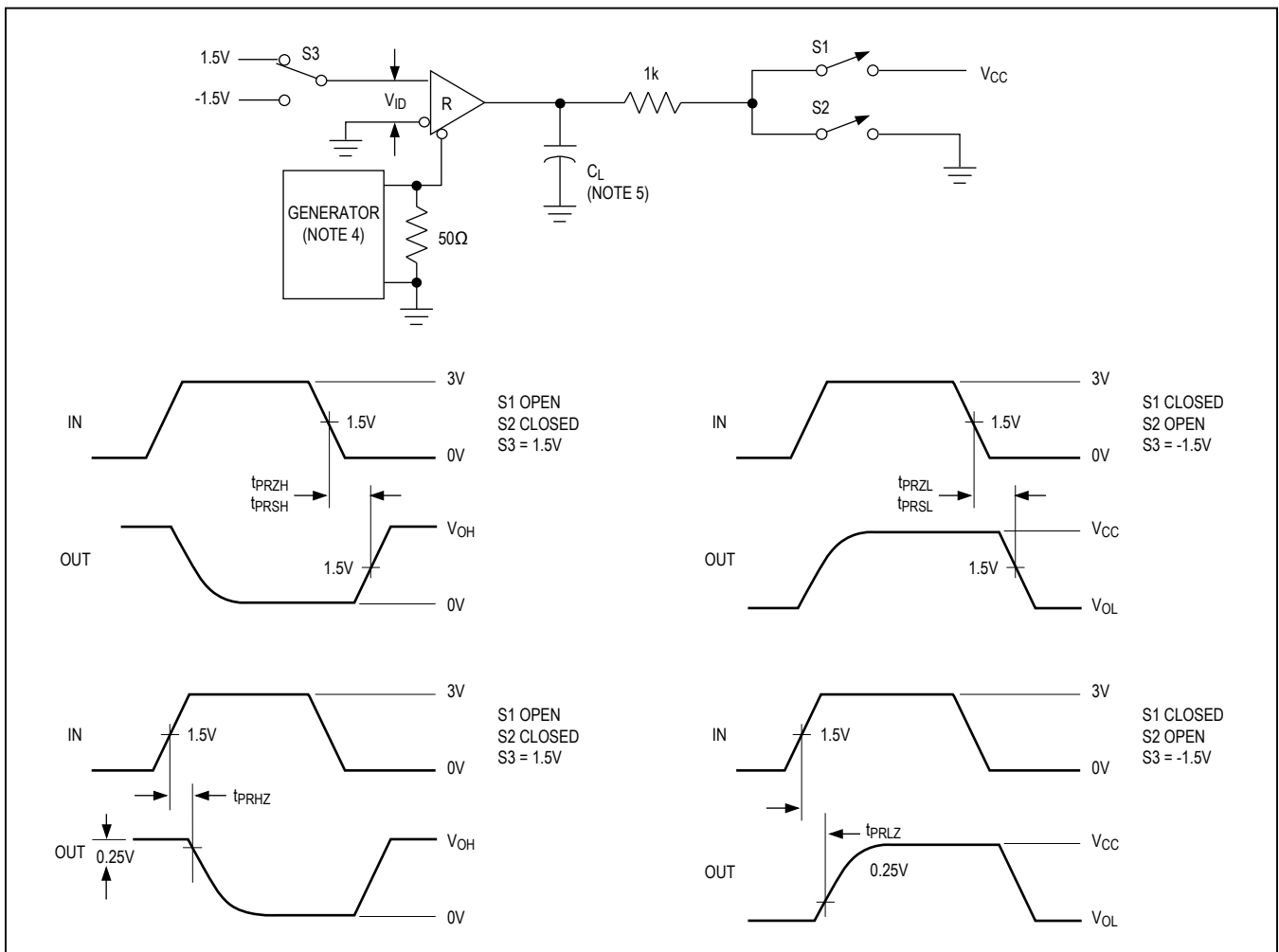

Figure 12. Receiver Enable and Disable Times

Note 4: The input pulse is supplied by a generator with the following characteristics: PRR = 250kHz, 50% duty cycle, $t_r \leq 6.0\text{ns}$, $Z_0 = 50\Omega$.

Note 5: C_L includes probe and stray capacitance.

MAX3483/MAX3485/
MAX3486/MAX3488/
MAX3490/MAX3491

3.3V-Powered, 10Mbps and Slew-Rate-Limited
True RS-485/RS-422 Transceivers

Function Tables

Devices with Receiver/Driver Enable
(MAX3483/MAX3485/MAX3486/MAX3491)

Table 1. Transmitting

| INPUTS | | | OUTPUTS | | MODE |
|-----------------|----|----|---------|--------|----------|
| \overline{RE} | DE | DI | B* | A* | |
| X | 1 | 1 | 0 | 1 | Normal |
| X | 1 | 0 | 1 | 0 | Normal |
| 0 | 0 | X | High-Z | High-Z | Normal |
| 1 | 0 | X | High-Z | High-Z | Shutdown |

* B and A outputs are Z and Y, respectively, for full-duplex part (MAX3491).

X = Don't care; High-Z = High impedance

Table 2. Receiving

| INPUTS | | | OUTPUTS | MODE |
|-----------------|----|--------------|---------|----------|
| \overline{RE} | DE | A, B | B* | |
| 0 | 0* | $\geq +0.2V$ | 1 | Normal |
| 0 | 0* | $\leq -0.2V$ | 0 | Normal |
| 0 | 0* | Inputs Open | 1 | Normal |
| 1 | 0 | X | High-Z | Shutdown |

* DE is a "don't care" (x) for the full-duplex part (MAX3491).

X = Don't care; High-Z = High impedance

Devices without Receiver/Driver Enable
(MAX3488/MAX3490)

Table 3. Transmitting Table 4. Receiving

| INPUT | OUTPUTS | |
|-------|---------|---|
| DI | Z | Y |
| 1 | 0 | 1 |
| 0 | 1 | 0 |

| INPUTS | OUTPUT |
|--------------|--------|
| A, B | RO |
| $\geq +0.2V$ | 1 |
| $\leq -0.2V$ | 0 |
| Inputs Open | 1 |

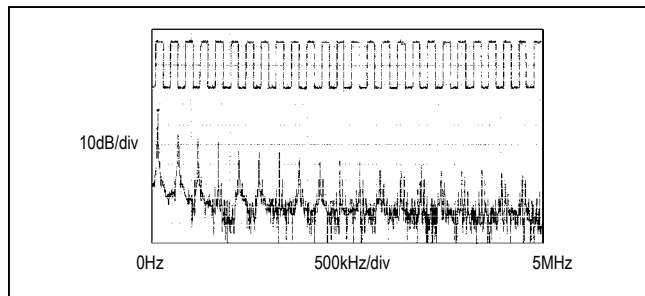

Figure 13. Driver Output Waveform and FFT Plot of MAX3485/MAX3490/MAX3491 Transmitting a 125kHz Signal

Applications Information

The MAX3483/MAX3485/MAX3486/MAX3488/MAX3490/MAX3491 are low-power transceivers for RS-485 and RS-422 communications. The MAX3483 and MAX3488 can transmit and receive at data rates up to 250kbps, the MAX3486 at up to 2.5Mbps, and the MAX3485/MAX3490/MAX3491 at up to 10Mbps. The MAX3488/MAX3490/MAX3491 are full-duplex transceivers, while the MAX3483/MAX3485/MAX3486 are half-duplex. Driver Enable (DE) and Receiver Enable (\overline{RE}) pins are included on the MAX3483/MAX3485/MAX3486/MAX3491. When disabled, the driver and receiver outputs are high impedance.

Reduced EMI and Reflections
(MAX3483/MAX3486/MAX3488)

The MAX3483/MAX3488 are slew-rate limited, minimizing EMI and reducing reflections caused by improperly terminated cables. Figure 13 shows both the driver output waveform of a MAX3485/MAX3490/MAX3491 transmitting a 125kHz signal and the Fourier analysis of that waveform. High-frequency harmonics with large amplitudes are evident. Figure 14 shows the same information, but for the slew-rate-limited MAX3483/MAX3488 transmitting the same signal. The high-frequency harmonics have much lower amplitudes, and the potential for EMI is significantly reduced.

Low-Power Shutdown Mode
(MAX3483/MAX3485/MAX3486/MAX3491)

A low-power shutdown mode is initiated by bringing both \overline{RE} high and DE low. The devices will not shut down unless both the driver and receiver are disabled (high impedance). In shutdown, the devices typically draw only 2nA of supply current.

For these devices, the t_{PSH} and t_{PSL} enable times assume the part was in the low-power shutdown mode; the t_{PZH} and t_{PZL} enable times assume the receiver or driver was disabled, but the part was not shut down.

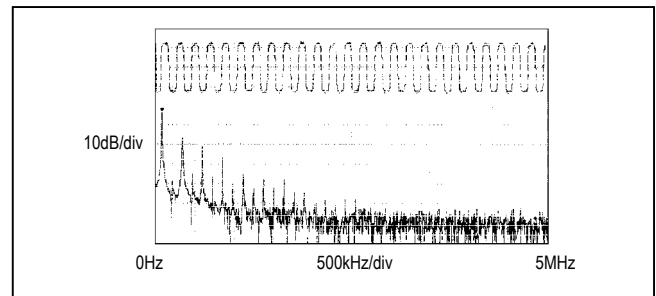

Figure 14. Driver Output Waveform and FFT Plot of MAX3483/MAX3488 Transmitting a 125kHz Signal

MAX3483/MAX3485/
MAX3486/MAX3488/
MAX3490/MAX3491

3.3V-Powered, 10Mbps and Slew-Rate-Limited
True RS-485/RS-422 Transceivers



Figure 15. MAX3485/MAX3490/MAX3491 Driver Propagation Delay

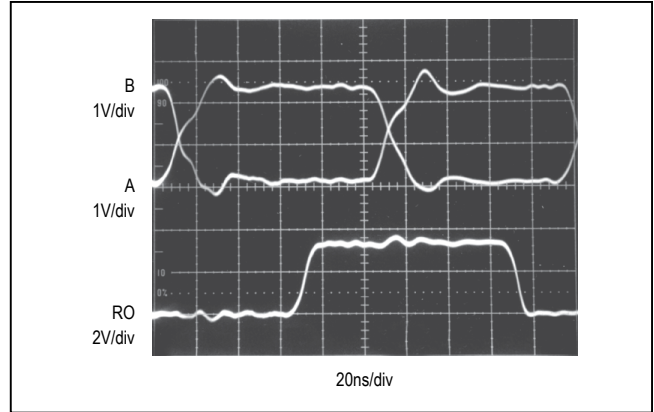

Figure 16. MAX3485/MAX3490/MAX3491 Receiver Propagation Delay Driven by External RS-485 Device



Figure 17. MAX3483/MAX3488 Driver Propagation Delay

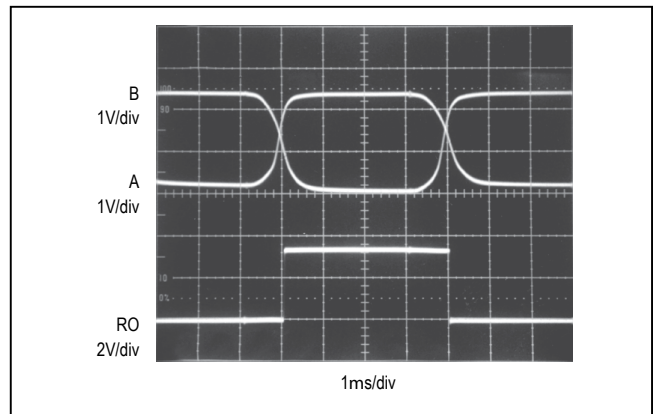

Figure 18. MAX3483/MAX3488 Receiver Propagation Delay

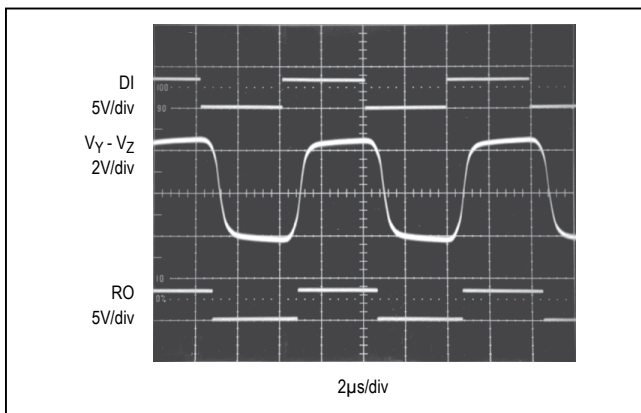

Figure 19. MAX3483/MAX3488 System Differential Voltage at 125kHz Driving 4000 ft of Cable

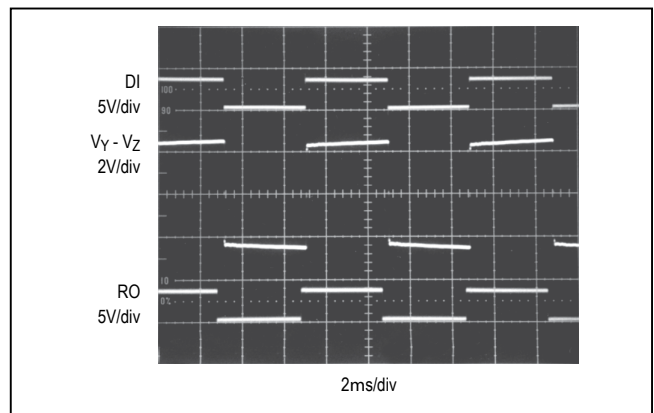

Figure 20. MAX3485/MAX3490/MAX3491 System Differential Voltage at 125kHz Driving 4000 ft of Cable

MAX3483/MAX3485/
MAX3486/MAX3488/
MAX3490/MAX3491

3.3V-Powered, 10Mbps and Slew-Rate-Limited
True RS-485/RS-422 Transceivers



Figure 21. MAX3483/MAX3485/MAX3486 Typical RS-485 Network

Driver Output Protection

Excessive output current and power dissipation caused by faults or by bus contention are prevented by two mechanisms. A foldback current limit on the output stage provides immediate protection against short circuits over the whole common-mode voltage range (see *Typical Operating Characteristics*). In addition, a thermal shut-down circuit forces the driver outputs into a high-impedance state if the die temperature rises excessively.

Propagation Delay

Figures 15–18 show the typical propagation delays. Skew time is simply the difference between the low-to-high and high-to-low propagation delay. Small driver/receiver skew times help maintain a symmetrical mark-space ratio (50% duty cycle).

The receiver skew time, $|t_{\text{PR LH}} - t_{\text{PR HL}}|$, is under 10ns (20ns for the MAX3483/MAX3488). The driver skew times are 8ns for the MAX3485/MAX3490/MAX3491, 11ns for the MAX3486, and typically under 100ns for the MAX3483/MAX3488.

Line Length vs. Data Rate

The RS-485/RS-422 standard covers line lengths up to 4000 feet. For line lengths greater than 4000 feet, see Figure 23.

Figures 19 and 20 show the system differential voltage for parts driving 4000 feet of 26AWG twisted-pair wire at 125kHz into 120Ω loads.

Typical Applications

The MAX3483, MAX3485, MAX3486, MAX3488, MAX3490, and MAX3491 transceivers are designed for bidirectional data communications on multipoint bus transmission lines. Figures 21 and 22 show typical network applications circuits. These parts can also be used as line repeaters, with cable lengths longer than 4000 feet, as shown in Figure 23.

To minimize reflections, the line should be terminated at both ends in its characteristic impedance, and stub lengths off the main line should be kept as short as possible. The slew-rate-limited MAX3483/MAX3488 and the partially slew-rate-limited MAX3486 are more tolerant of imperfect termination.

MAX3483/MAX3485/
MAX3486/MAX3488/
MAX3490/MAX3491

3.3V-Powered, 10Mbps and Slew-Rate-Limited
True RS-485/RS-422 Transceivers

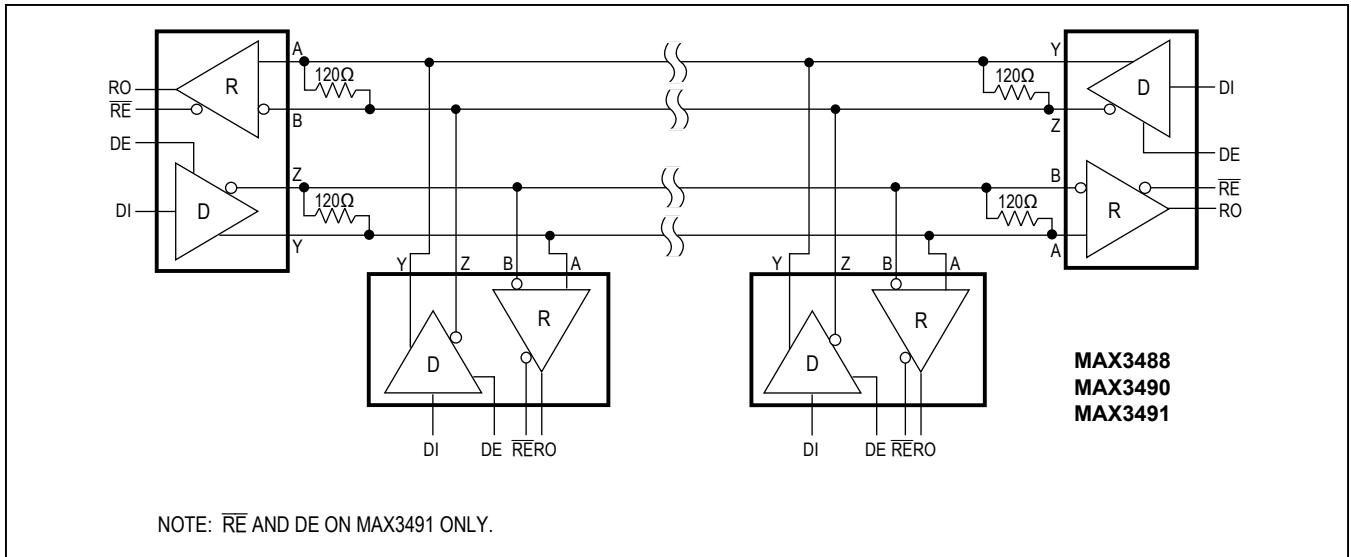

Figure 22. MAX3488/MAX3490/MAX3491 Full-Duplex RS-485 Network

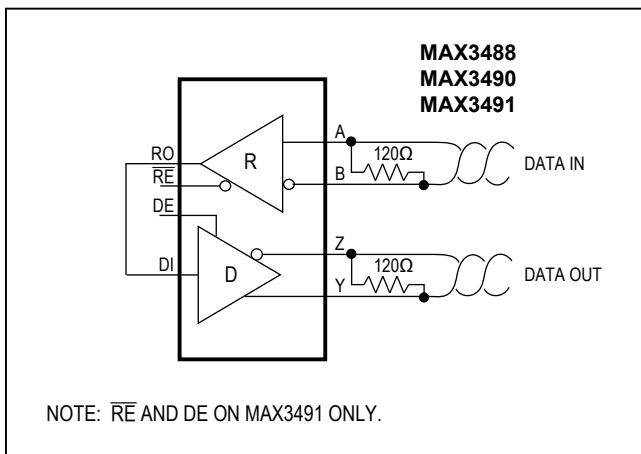

Figure 23. Line Repeater for MAX3488/MAX3490/MAX3491

MAX3483/MAX3485/
 MAX3486/MAX3488/
 MAX3490/MAX3491

3.3V-Powered, 10Mbps and Slew-Rate-Limited
 True RS-485/RS-422 Transceivers

Ordering Information (continued)

| | | |
|--------------------|----------------|----------------|
| MAX3486 CPA | 0°C to +70°C | 8 Plastic DIP |
| MAX3486CSA | 0°C to +70°C | 8 SO |
| MAX3486C/D | 0°C to +70°C | Dice* |
| MAX3486EPA | -40°C to +85°C | 8 Plastic DIP |
| MAX3486ESA | -40°C to +85°C | 8 SO |
| MAX3488 CPA | 0°C to +70°C | 8 Plastic DIP |
| MAX3488CSA | 0°C to +70°C | 8 SO |
| MAX3488C/D | 0°C to +70°C | Dice* |
| MAX3488EPA | -40°C to +85°C | 8 Plastic DIP |
| MAX3488ESA | -40°C to +85°C | 8 SO |
| MAX3490 CPA | 0°C to +70°C | 8 Plastic DIP |
| MAX3490CSA | 0°C to +70°C | 8 SO |
| MAX3490C/D | 0°C to +70°C | Dice* |
| MAX3490EPA | -40°C to +85°C | 8 Plastic DIP |
| MAX3490ESA | -40°C to +85°C | 8 SO |
| MAX3491 CPD | 0°C to +70°C | 14 Plastic DIP |
| MAX3491CSD | 0°C to +70°C | 14 SO |
| MAX3491C/D | 0°C to +70°C | Dice* |
| MAX3491EPD | -40°C to +85°C | 14 Plastic DIP |
| MAX3491ESD | -40°C to +85°C | 14 SO |

* Contact factory for for dice specifications.

Chip Topography



TRANSISTOR COUNT: 810
 SUBSTRATE CONNECTED TO GROUND

MAX3483/MAX3485/
MAX3486/MAX3488/
MAX3490/MAX3491

3.3V-Powered, 10Mbps and Slew-Rate-Limited
True RS-485/RS-422 Transceivers

Revision History

| REVISION NUMBER | REVISION DATE | DESCRIPTION | PAGES CHANGED |
|-----------------|---------------|--|---------------|
| 0 | 12/94 | Initial release | — |
| 1 | 5/19 | Updated Absolute Maximum Ratings and added Package Information section | 2 |

For pricing, delivery, and ordering information, please visit Maxim Integrated's online storefront at <https://www.maximintegrated.com/en/storefront/storefront.html>.

Maxim Integrated cannot assume responsibility for use of any circuitry other than circuitry entirely embodied in a Maxim Integrated product. No circuit patent licenses are implied. Maxim Integrated reserves the right to change the circuitry and specifications without notice at any time. The parametric values (min and max limits) shown in the Electrical Characteristics table are guaranteed. Other parametric values quoted in this data sheet are provided for guidance.

Looking for pricing, stock, or lifecycle information?

Click below to explore more details on WIN SOURCE:

 [View MAX3491ESD+T on WIN SOURCE](#)

 [Maxim Integrated](#) Information

Optimize Your Supply Chain with WIN SOURCE Solutions

-  Global Sourcing Solution
-  Obsolete Management
-  Cost Control Management
-  Shortage Management
-  Alternative Solution
-  Excess Inventory Management