



# MAX3394E/MAX3395E/ MAX3396E

# ±15kV ESD-Protected, High-Drive Current, Dual-/Quad-/Octal-Level Translators with Speed-Up Circuitry

## General Description

The MAX3394E/MAX3395E/MAX3396E bidirectional level translators provide level shifting required for data transfer in a multivoltage system. Internal slew-rate enhancement circuitry features 10mA current-sink and 15mA current-source drivers to isolate capacitive loads from lower current drivers. In open-drain systems, slew-rate enhancement enables fast data rates with larger pullup resistors and increased bus load capacitance. Externally applied voltages,  $V_{CC}$  and  $V_L$ , set the logic-high levels for the device. A logic-low signal on one I/O side of the device appears as a logic-low signal on the opposite I/O side, and vice-versa. Each I/O line is pulled up to  $V_{CC}$  or  $V_L$  by an internal pullup resistor, allowing the devices to be driven by either push-pull or open-drain drivers.

The MAX3394E/MAX3395E/MAX3396E feature a tri-state output mode, thermal-shutdown protection, and ±15kV Human Body Model (HBM) ESD protection on the  $V_{CC}$  side for greater protection in applications that route signals externally.

The MAX3394E/MAX3395E/MAX3396E accept  $V_{CC}$  voltages from +1.65V to +5.5V, and  $V_L$  voltages from +1.2V to  $V_{CC}$ , making them ideal for data transfer between low voltage ASIC/PLDs and higher voltage systems. The MAX3394E/MAX3395E/MAX3396E operate at a guaranteed data rate of 6Mbps with push-pull drivers and 1Mbps with open-drain drivers.

The MAX3394E is a dual-level translator available in 9-bump UCSP™ and 8-pin 3mm x 3mm TDFN packages. The MAX3395E is a quad-level translator available in 12-bump UCSP, and 12-pin 4mm x 4mm TQFN packages. The MAX3396E is an octal-level translator available in 20-bump UCSP and 20-pin 5mm x 5mm TQFN packages. The MAX3394E/MAX3395E/MAX3396E operate over the extended -40°C to +85°C temperature range.

## Applications

- Multivoltage Bidirectional Level Translation
- SPI™, MICROWIRE™, and I<sup>2</sup>C Level Translation
- Open-Drain Rise-Time Speed-Up
- High-Speed Bus Fan-Out Expansion
- Cell Phones
- Telecom, Networking, Servers, RAID/SAN

MICROWIRE is a trademark of National Semiconductor Corp.

SPI is a trademark of Motorola, Inc.

UCSP is a trademark of Maxim Integrated Products, Inc.

## Features

- ±15kV ESD Protection on I/O  $V_{CC}$  Lines
- Bidirectional Level Translation Without Direction Pin
- I/O  $V_L$  and I/O  $V_{CC}$  10mA Sink-/15mA Source-Current Capability
- Slew-Rate Enhancement Circuitry Supports
- Larger Capacitive Loads or Larger External Pullup Resistors
- 6Mbps Push-Pull/1Mbps Open-Drain Guaranteed Data Rate
- Wide Supply-Voltage Range: Operation Down to +1.2V on  $V_L$  and +1.65V on  $V_{CC}$
- Low Supply Current in Tri-State Output Mode (3µA typ)
- Low Quiescent Current
- Thermal-Shutdown Protection
- UCSP, TDFN, and TQFN Packages

## Ordering Information

PART	PIN-PACKAGE	PKG CODE
MAX3394EETA+T	8 TDFN-EP**	T833-1
MAX3394EEBL+T	9 UCSP	B9-5
MAX3395EETC+	12 TQFN-EP**	T1244-4
MAX3395EEBC+T	12 UCSP	B12-1
MAX3396EEBP+T*	20 UCSP	B20-1
MAX3396EETP+*	20 TQFN-EP**	T2055-4

**Note:** All devices specified over the -40°C to +85°C operating range.

+Denotes lead(Pb)-free/RoHS-compliant package.

\*Future product—contact factory for availability.

\*\*EP = Exposed paddle.

**Selector Guide appears at end of data sheet.**

## Pin Configurations

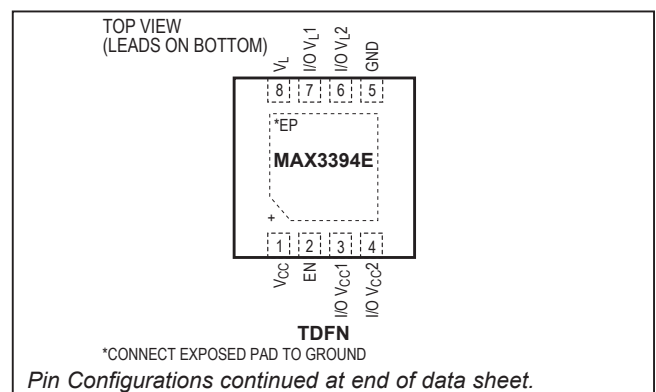

MAX3394E/MAX3395E/  
MAX3396E

±15kV ESD-Protected, High-Drive Current,  
Dual-/Quad-/Octal-Level Translators with  
Speed-Up Circuitry

**Absolute Maximum Ratings**

(All voltages referenced to GND.)

V<sub>CC</sub>.....-0.3V to +6V  
V<sub>L</sub>.....-0.3V to +6V  
I/O V<sub>CC</sub>.....-0.3V to V<sub>CC</sub> + 0.3V  
I/O V<sub>L</sub>..... -0.3V to V<sub>L</sub> + 0.3V  
EN.....-0.3V to +6V  
Short-Circuit Duration I/O V<sub>L</sub>, I/O V<sub>CC</sub> to GND..... Continuous  
Maximum Continuous Current..... ±50mA  
Continuous Power Dissipation (T<sub>A</sub> = +70°C)  
8-Pin TDFN (derate 18.2mW/°C above +70°C) .....1455mW  
9-Bump UCSP (derate 4.7mW/°C above +70°C).....379mW

12-Pin TQFN (derate 16.9mW/°C above +70°C).....1349mW  
12-Bump UCSP (derate 6.5mW/°C above +70°C).....519mW  
20-Pin TQFN (derate 20.8mW/°C above +70°C).....1667mW  
20-Bump UCSP (derate 10.0mW/°C above +70°C).....800mW  
Operating Temperature Range..... -40°C to +85°C  
Storage Temperature Range..... -65°C to +150°C  
Junction Temperature..... +150°C  
Bump Temperature (soldering)..... +235°C  
Lead Temperature (soldering, 10s) ..... +300°C

Stresses beyond those listed under "Absolute Maximum Ratings" may cause permanent damage to the device. These are stress ratings only, and functional operation of the device at these or any other conditions beyond those indicated in the operational sections of the specifications is not implied. Exposure to absolute maximum rating conditions for extended periods may affect device reliability.

**Electrical Characteristics**

(V<sub>CC</sub> = +1.65V to +5.5V, V<sub>L</sub> = +1.2V to V<sub>CC</sub>; C<sub>IOVL</sub> ≤ 15pF, C<sub>IOVCC</sub> ≤ 15pF; T<sub>A</sub> = -40°C to +85°C, unless otherwise noted. Typical values are at T<sub>A</sub> = +25°C.) (Note 1)

PARAMETER	SYMBOL	CONDITIONS	MIN	TYP	MAX	UNITS
<b>POWER SUPPLY</b>						
V <sub>L</sub> Supply Range	V <sub>L</sub>		1.2		V <sub>CC</sub>	V
V <sub>CC</sub> Supply Range	V <sub>CC</sub>		1.65		5.50	V
Supply Current from V <sub>CC</sub>	I <sub>CC</sub>	I/O lines internally pulled up			150	μA
					300	
					600	
Supply Current from V <sub>L</sub>	I <sub>L</sub>	I/O lines internally pulled up			30	μA
					30	
					30	
V <sub>CC</sub> Tri-State Supply Current	I <sub>CC-3</sub>	EN = GND, T <sub>A</sub> = +25°C		3	6	μA
V <sub>L</sub> Tri-State Supply Current	I <sub>L-3</sub>	EN = GND, T <sub>A</sub> = +25°C		0.7	2	μA
<b>LOGIC I/O</b>						
I/O V <sub>L</sub> Input-Voltage High Threshold	V <sub>IHL</sub>		0.7 x V <sub>L</sub>			V
I/O V <sub>L</sub> Input-Voltage Low Threshold	V <sub>ILL</sub>				0.3 x V <sub>L</sub>	V
I/O V <sub>L</sub> Internal Pullup DC Resistance	R <sub>L</sub>	EN = V <sub>CC</sub> or V <sub>L</sub>	5	10	20	kΩ
I/O V <sub>L</sub> Source Current During Low-to-High Transition	I <sub>IHL</sub>	V <sub>L</sub> = +1.2V		15		mA
I/O V <sub>L</sub> Sink Current During High-to-Low Transition	I <sub>ILL</sub>	V <sub>CC</sub> = +1.65V		10		mA

MAX3394E/MAX3395E/  
MAX3396E

±15kV ESD-Protected, High-Drive Current,  
Dual-/Quad-/Octal-Level Translators with  
Speed-Up Circuitry

**Electrical Characteristics (continued)**

( $V_{CC} = +1.65V$  to  $+5.5V$ ,  $V_L = +1.2V$  to  $V_{CC}$ ;  $C_{IOVL} \leq 15pF$ ,  $C_{IOVCC} \leq 15pF$ ;  $T_A = -40^\circ C$  to  $+85^\circ C$ , unless otherwise noted. Typical values are at  $T_A = +25^\circ C$ .) (Note 1)

PARAMETER	SYMBOL	CONDITIONS	MIN	TYP	MAX	UNITS
I/O $V_L$ Low-to-High Transition Threshold	$V_{L-TH}$	$V_{CC} = +3.3V$ , $V_L = +1.8V$	$0.3 \times V_L$	$0.5 \times V_L$		V
I/O $V_L$ Output-Voltage Low	$V_{OLL}$	I/O $V_L$ sink current = 5mA, $V_{ILC} = 0V$			0.25	V
		I/O $V_L$ sink current = 10mA, $V_{ILC} \leq 0.4V$ or $0.2 \times V_L$			$V_{ILC} + 0.4V$	
I/O $V_L$ Tri-State Output Leakage Current		EN = GND, $T_A = +25^\circ C$	-1		+1	$\mu A$
I/O $V_{CC}$ Input-Voltage High Threshold	$V_{IHC}$	(Note 2)	$0.7 \times V_{CC}$			V
I/O $V_{CC}$ Input-Voltage Low Threshold	$V_{ILC}$	(Note 2)			$0.3 \times V_{CC}$	V
I/O $V_{CC}$ Internal Pullup DC Resistance	$R_{CC}$	EN = $V_{CC}$ or $V_L$	5	10	20	k $\Omega$
I/O $V_{CC}$ Source Current During Low-to-High Transition	$I_{IHCC}$	$V_{CC} = +1.65V$		15		mA
I/O $V_{CC}$ Sink Current During High-to-Low Transition	$I_{ILCC}$	$V_{CC} = +1.65V$		10		mA
I/O $V_{CC}$ Low-to-High Transition Threshold	$V_{CC-TH}$	$V_{CC} = +3.3V$ , $V_L = +1.8V$	$0.3 \times V_{CC}$	$0.5 \times V_{CC}$		V
I/O $V_{CC}$ Output-Voltage Low	$V_{OLC}$	I/O $V_{CC}$ sink current = 5mA, $V_{ILL} = 0V$			0.25	V
		I/O $V_{CC}$ sink current = 10mA, $V_{ILL} \leq 0.4V$ or $0.2 \times V_L$			$V_{ILL} + 0.4V$	
I/O $V_{CC}$ Tri-State Output Leakage Current		EN = GND, $T_A = +25^\circ C$	-1		+1	$\mu A$
EN Input-Voltage High Threshold	$V_{IHE}$		$0.7 \times V_L$			V
EN Input-Voltage Low Threshold	$V_{ILE}$				$0.3 \times V_L$	V
EN Pin Input Leakage Current		$T_A = +25^\circ C$	-1		+1	$\mu A$
<b>ESD PROTECTION</b>						
I/O $V_{CC}$ ESD Protection		$C_{VCC} = 1\mu F$ , Human Body Model		$\pm 15$		kV

### Timing Characteristics

( $V_{CC} = +1.65V$  to  $+5.5V$ ,  $V_L = +1.2V$  to  $V_{CC}$ ;  $C_{IOVL} \leq 15pF$ ,  $C_{IOVCC} \leq 15pF$ ;  $T_A = -40^\circ C$  to  $+85^\circ C$ , unless otherwise noted. Typical values are at  $T_A = +25^\circ C$ .) (Note 1)

PARAMETER	SYMBOL	CONDITIONS	MIN	TYP	MAX	UNITS
I/O $V_{CC}$ _ Rise Time	$t_{RVCC}$	Push-pull driver, Figure 1			50	ns
		Open-drain driver, internal pullup, Figure 2			500	
I/O $V_{CC}$ _ Fall Time	$t_{FVCC}$	Push-pull driver, Figure 1			50	ns
		Open-drain driver, internal pullup, Figure 2			50	
I/O $V_L$ _ Rise Time	$t_{RVL}$	Push-pull driver, Figure 3			50	ns
		Open-drain driver, internal pullup, Figure 4			500	
I/O $V_L$ _ Fall Time	$t_{FVL}$	Push-pull driver, Figure 3			50	ns
		Open-drain driver, internal pullup, Figure 4			50	
Propagation Delay	$t_{I/OVL-VCC}$	Push-pull driver, Figure 1			50	ns
		Open-drain driver, internal pullup, Figure 2			600	
	$t_{I/OVCC-VL}$	Push-pull driver, Figure 3			50	
		Open-drain driver, internal pullup, Figure 4			600	
Propagation Delay After EN	$t_{EN}$	Push-pull or open-drain driver, Figure 5			5	$\mu s$
Channel-to-Channel Skew	$t_{SKEW}$	Push-pull driver			5	ns
		Open-drain driver, internal pullup			100	
Maximum Data Rate		Push-pull driver, Figures 1, 3			6	Mbps
		Open-drain driver, internal pullup, Figures 2, 4			1	

**Note 1:** All units are 100% production tested at  $T_A = +25^\circ C$ . Limits over the operating temperature range are guaranteed by design and not production tested.

**Note 2:** During a low-to-high transition, the threshold at which the I/O changes state is the lower of  $V_{ILL}$  and  $V_{ILC}$  since the two sides are internally connected by an internal switch while the device is in the logic-low state.

# MAX3394E/MAX3395E/ MAX3396E

±15kV ESD-Protected, High-Drive Current,  
Dual-/Quad-/Octal-Level Translators with  
Speed-Up Circuitry

## Typical Operating Characteristics

( $V_{CC} = +2.5V$ ,  $V_L = +1.8V$ ,  $C_L = 15pF$ ,  $T_A = +25^\circ C$ , unless otherwise noted.)

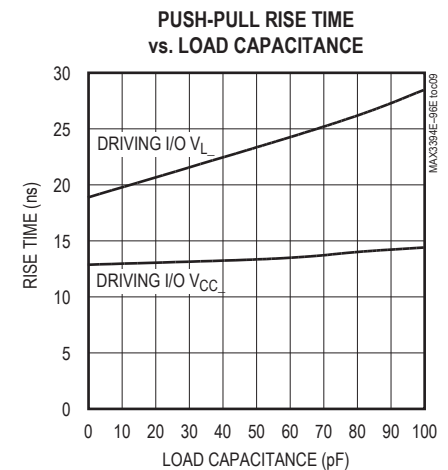
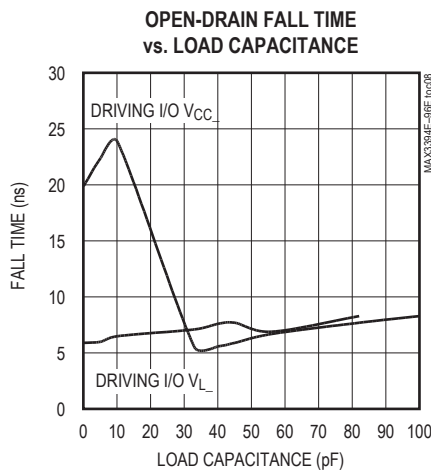
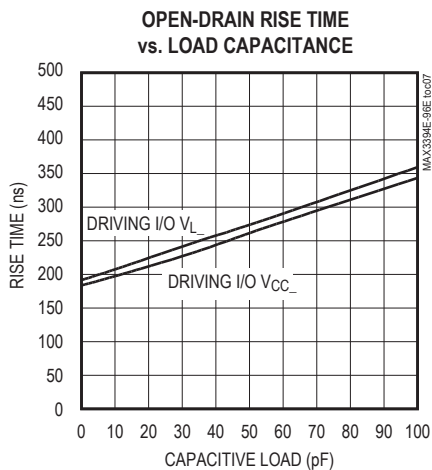
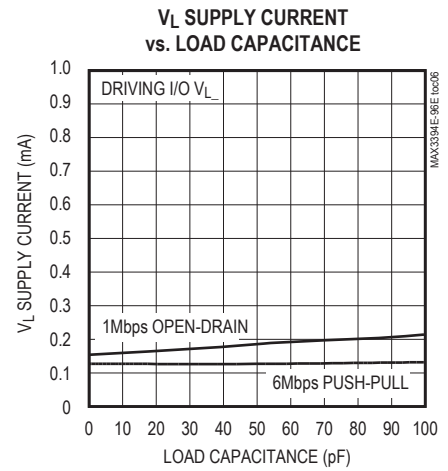
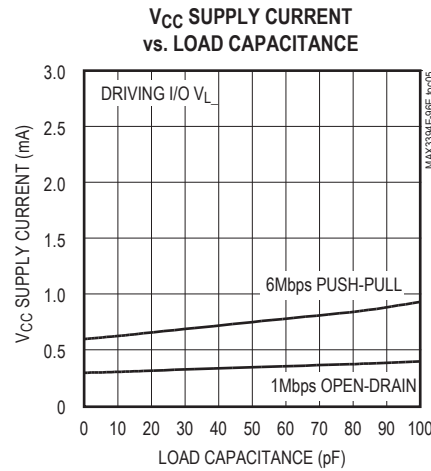
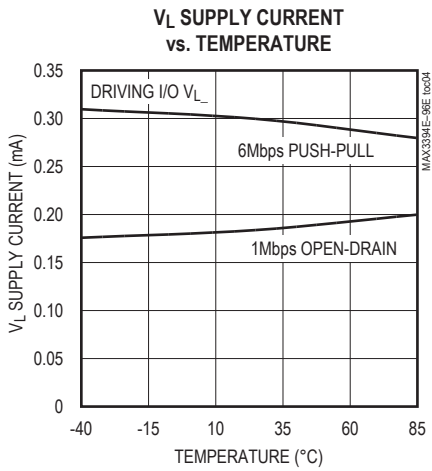
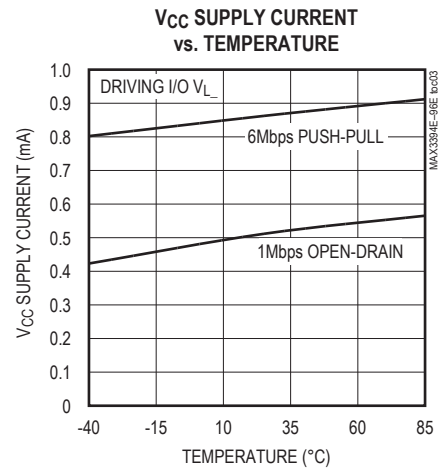
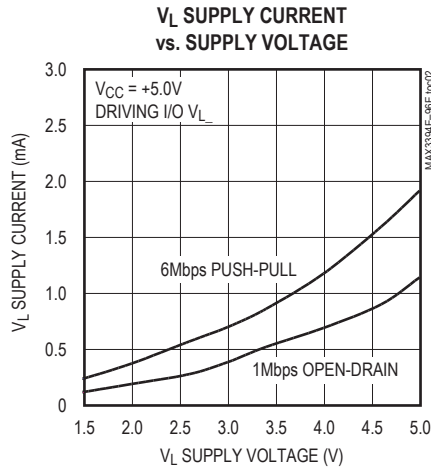
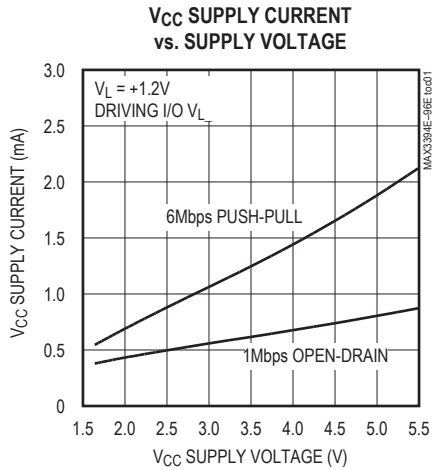

MAX3394E/MAX3395E/  
MAX3396E

±15kV ESD-Protected, High-Drive Current,  
Dual-/Quad-/Octal-Level Translators with  
Speed-Up Circuitry

Typical Operating Characteristics (continued)

( $V_{CC} = +2.5V$ ,  $V_L = +1.8V$ ,  $C_L = 15pF$ ,  $T_A = +25^\circ C$ , unless otherwise noted.)

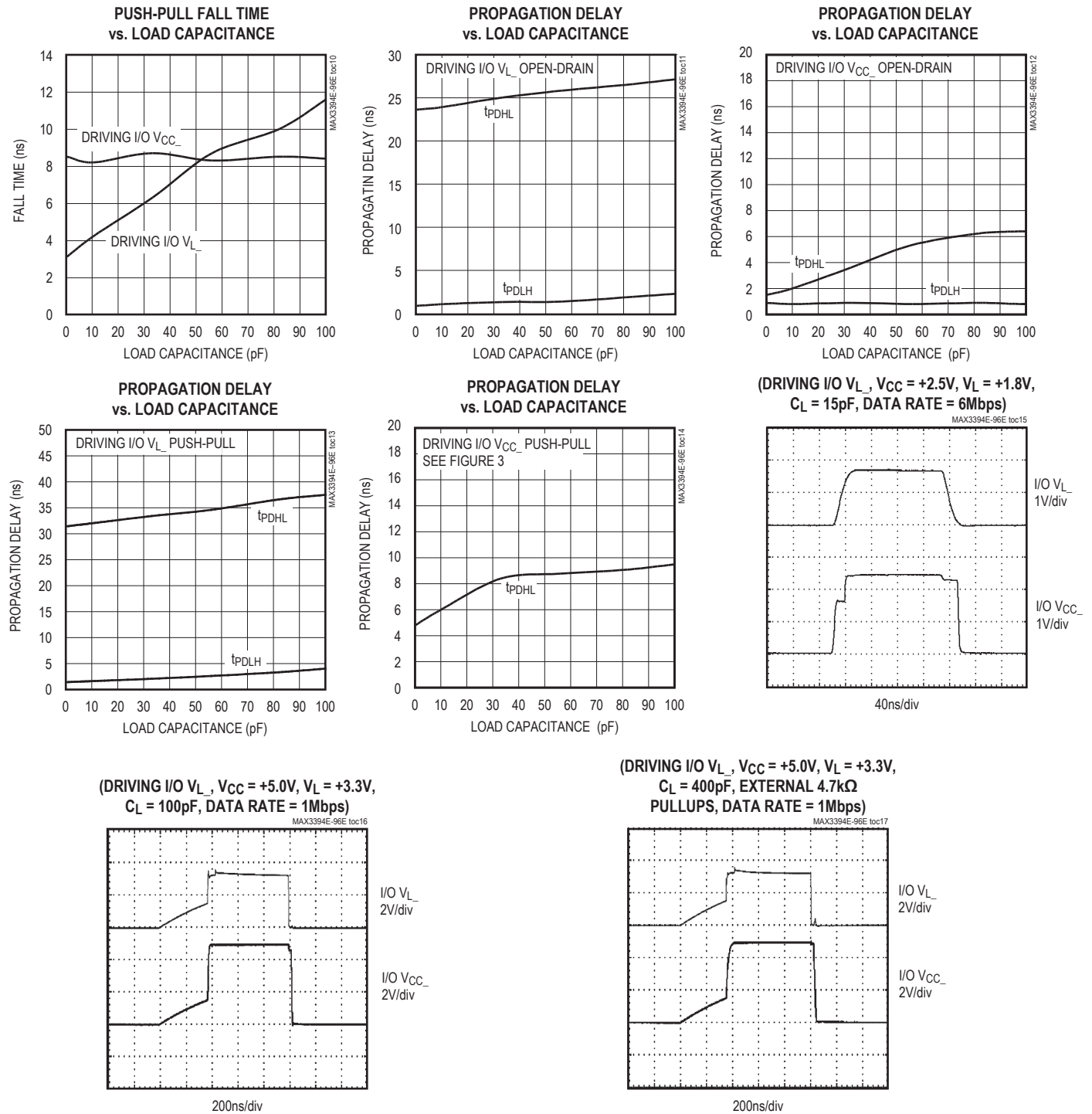

## Pin Description

PIN						NAME	FUNCTION
MAX3394E		MAX3395E		MAX3396E			
TDFN	UCSP	TQFN	UCSP	TQFN	UCSP		
1	A1	11	B1	14	D3	V <sub>CC</sub>	V <sub>CC</sub> Supply Voltage +1.65V ≤ V <sub>CC</sub> ≤ +5.5V. Bypass V <sub>CC</sub> to GND with a 0.1μF ceramic capacitor and a 1μF or greater ceramic capacitor as close to the device as possible.
2	B1	6	B3	4	A4	EN	Enable Input. Drive EN logic high for normal operation. Drive EN logic low to force all I/O lines to a high-impedance state and disconnect internal pullup resistors.
3	A2	10	C1	18	C1	I/O V <sub>CC</sub> 1	I/O 1 Referred to V <sub>CC</sub>
4	A3	9	C2	16	D1	I/O V <sub>CC</sub> 2	I/O 2 Referred to V <sub>CC</sub>
5	B3	5	B4	13	D4	GND	Ground
6	C3	2	A2	20	A1	I/O V <sub>L</sub> 2	I/O 2 Referred to V <sub>L</sub>
7	C2	1	A1	19	B1	I/O V <sub>L</sub> 1	I/O 1 Referred to V <sub>L</sub>
8	C1	12	B2	3	A3	V <sub>L</sub>	Logic Supply Voltage +1.2V ≤ V <sub>L</sub> ≤ V <sub>CC</sub> . Bypass V <sub>L</sub> to GND with a 0.1μF or greater ceramic capacitor as close to the device as possible.
—	—	3	A3	1	B2	I/O V <sub>L</sub> 3	I/O 3 Referred to V <sub>L</sub>
—	—	4	A4	2	A2	I/O V <sub>L</sub> 4	I/O 4 Referred to V <sub>L</sub>
—	—	7	C4	15	D2	I/O V <sub>CC</sub> 4	I/O 4 Referred to V <sub>CC</sub>
—	—	8	C3	17	C2	I/O V <sub>CC</sub> 3	I/O 3 Referred to V <sub>CC</sub>
—	—	—	—	12	C3	I/O V <sub>CC</sub> 5	I/O 5 Referred to V <sub>CC</sub>
—	—	—	—	11	D5	I/O V <sub>CC</sub> 6	I/O 6 Referred to V <sub>CC</sub>
—	—	—	—	10	C4	I/O V <sub>CC</sub> 7	I/O 7 Referred to V <sub>CC</sub>
—	—	—	—	9	C5	I/O V <sub>CC</sub> 8	I/O 8 Referred to V <sub>CC</sub>
—	—	—	—	5	B3	I/O V <sub>L</sub> 5	I/O 5 Referred to V <sub>L</sub>
—	—	—	—	6	A5	I/O V <sub>L</sub> 6	I/O 6 Referred to V <sub>L</sub>
—	—	—	—	7	B4	I/O V <sub>L</sub> 7	I/O 7 Referred to V <sub>L</sub>
—	—	—	—	8	B5	I/O V <sub>L</sub> 8	I/O 8 Referred to V <sub>L</sub>
EP	—	EP	—	EP	—	EP	Exposed Pad. Connect exposed pad to GND.

## Detailed Description

The MAX3394E/MAX3395E/MAX3396E bidirectional level translators provide level shifting required for data transfer in a multivoltage system. Internal slew-rate enhancement circuitry features 10mA current-sink and 15mA current-source drivers to isolate capacitive loads from lower current drivers. In open-drain systems, slew-rate enhancement enables fast data rates with larger pullup resistors

and increased bus load capacitance. Externally applied voltages, V<sub>CC</sub> and V<sub>L</sub>, set the logic-high levels for the device. A logic-low signal on one I/O side of the device appears as a logic-low signal on the opposite I/O side and vice-versa. Each I/O line is pulled up to V<sub>CC</sub> or V<sub>L</sub> by an internal pullup resistor, allowing the devices to be driven by either push-pull or open-drain drivers.

MAX3394E/MAX3395E/  
MAX3396E

±15kV ESD-Protected, High-Drive Current,  
Dual-/Quad-/Octal-Level Translators with  
Speed-Up Circuitry

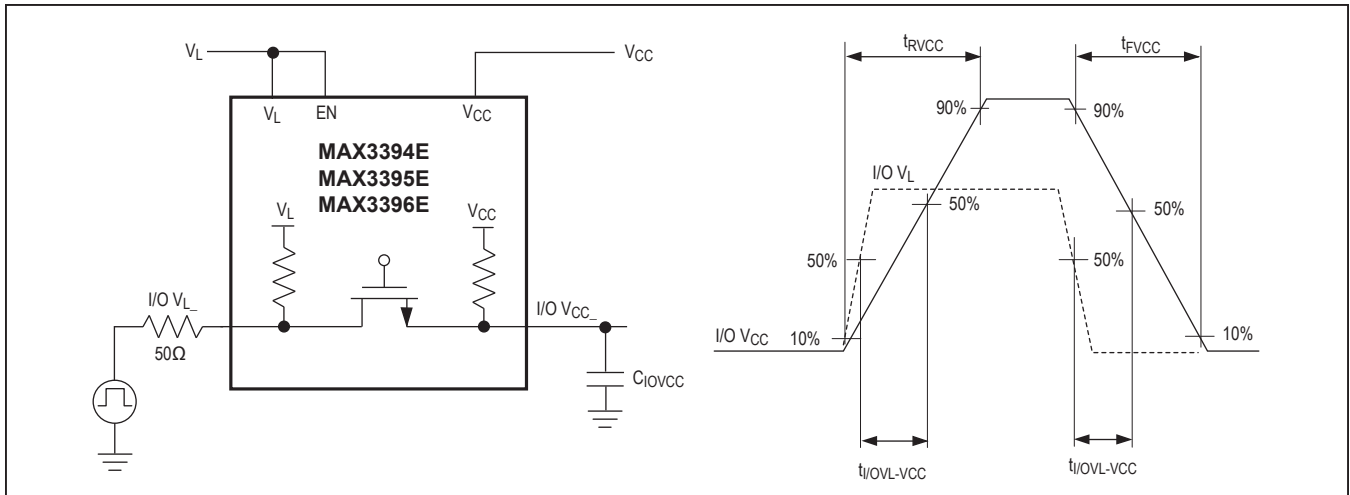

Figure 1. Push-Pull Driving I/O  $V_L$  Test Circuit and Timing

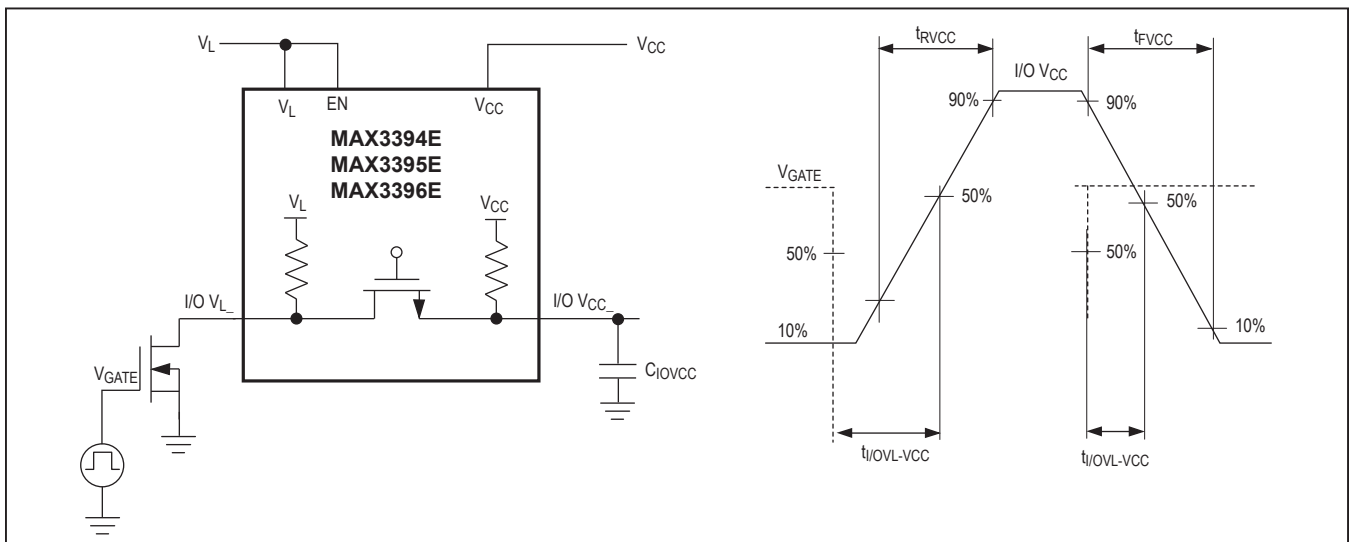

Figure 2. Open-Drain Driving I/O  $V_L$  Test Circuit and Timing

The MAX3394E/MAX3395E/MAX3396E feature a tri-state output mode, thermal-shutdown protection, and ±15kV Human Body Model (HBM) ESD protection on the  $V_{CC}$  side for greater protection in applications that route signals externally.

The MAX3394E/MAX3395E/MAX3396E accept  $V_{CC}$  voltages from +1.65V to +5.5V, and  $V_L$  voltages from +1.2V to  $V_{CC}$ , making them ideal for data transfer between low-voltage ASIC/PLDs and higher voltage systems. The MAX3394E/MAX3395E/MAX3396E operate at a guaran-

teed data rate of 6Mbps with push-pull drivers and 1Mbps with open-drain drivers.

**Level Translation**

The MAX3394E/MAX3395E/MAX3396E utilize a transmission gate architecture to provide bidirectional level translation between I/O  $V_L$  and I/O  $V_{CC}$ . The transmission gate architecture is comprised of a pass-FET, gate-control logic, and slew-rate enhancement circuitry. When both I/O  $V_L$  and I/O  $V_{CC}$  are logic high, the gate-control logic disables the pass-FET, providing

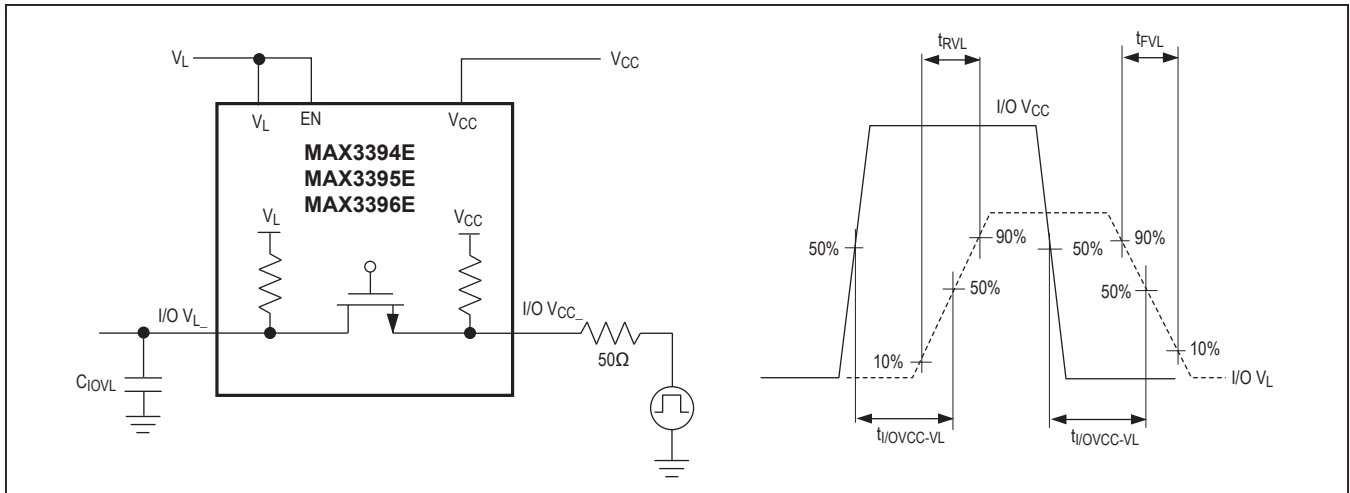

Figure 3. Push-Pull Driving I/O V<sub>CC</sub>\_ Test Circuit and Timing

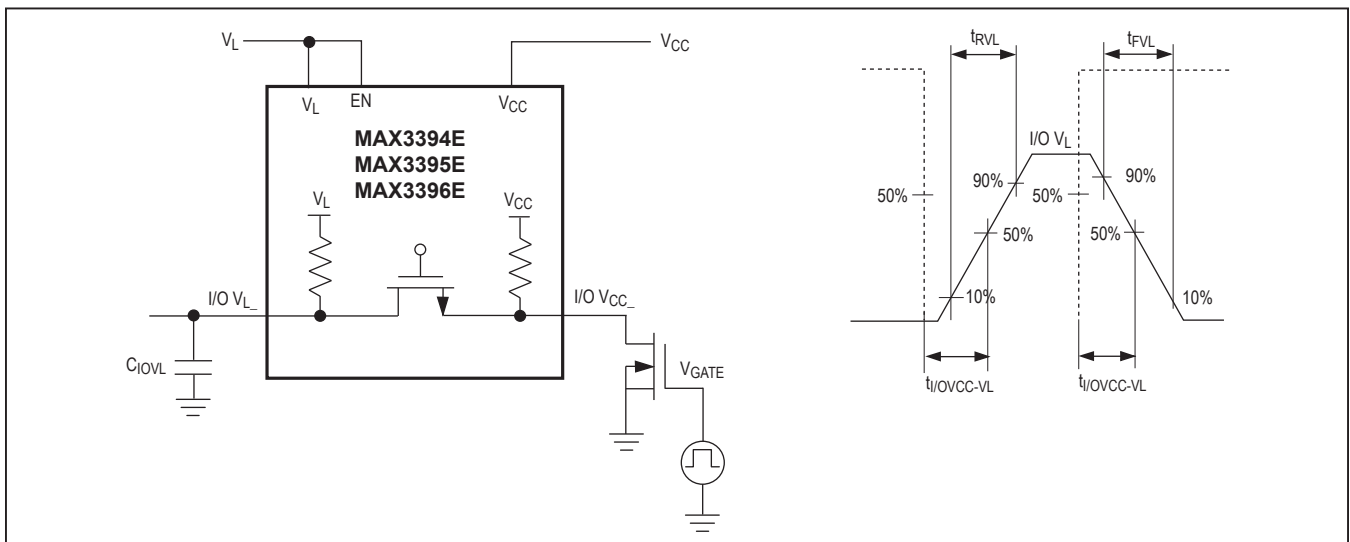

Figure 4. Open-Drain Driving I/O V<sub>CC</sub>\_ Test Circuit and Timing

capacitive isolation between I/O lines. When one or both I/O lines are at a logic-low level, the gate-control logic turns the pass-FET on. When the pass-FET is active, I/O V<sub>L</sub> and I/O V<sub>CC</sub> are connected, allowing the logic-low signal to be expressed simultaneously on both I/O lines.

The MAX3394E/MAX3395E/MAX3396E have internal 10kΩ (typ) pullup resistors from I/O V<sub>L</sub> and I/O V<sub>CC</sub> to the respective supply voltages, allowing operation with open-drain drivers. Internal slew-rate enhancement circuitry accelerates logic-state transitions, maintaining a fast data rate with a higher bus load capacitance. Additionally, the 10mA current sink drivers permit the use of smaller external pullup resistors.

### Internal Slew-Rate Enhancement

Internal slew-rate enhancement circuitry accelerates logic-state changes by turning on MOSFETs M<sub>P1</sub> and M<sub>P2</sub> during low-to-high logic transitions, and MOSFETs M<sub>N3</sub> and M<sub>N4</sub> during high-to-low logic transitions (see the *Functional Diagram*). During logic-state changes, speed-up MOSFETs are triggered by I/O line voltage thresholds. MOSFETs M<sub>N3</sub> and M<sub>N4</sub> sink 10mA during high-to-low logic transitions. M<sub>P1</sub> and M<sub>P2</sub> source 15mA during low-to-high logic transitions. Slew-rate enhancement allows a fast data rate despite large capacitive bus loads, and permits larger external pullup resistors.

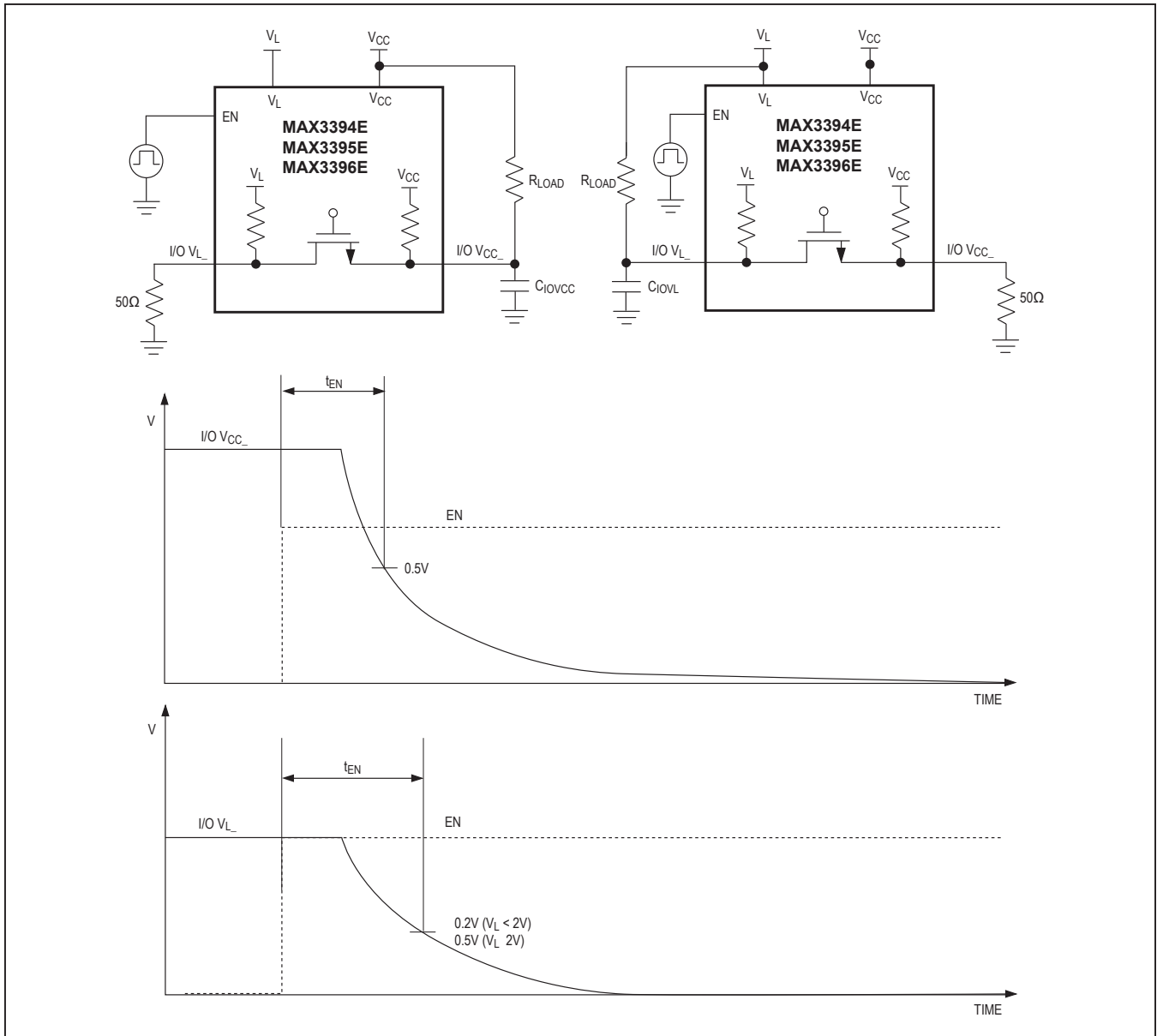

Figure 5. Enable Test Circuit and Timing

### Power-Supply Sequencing

The MAX3394E/MAX3395E/MAX3396E require two supply voltages. For proper operation, ensure that  $+1.65\text{V} \leq V_{CC} \leq +5.5\text{V}$ , and  $+1.2\text{V} \leq V_L \leq V_{CC}$ . There are no restrictions on power-supply sequencing. During power-up or power-down, the MAX3394E/MAX3395E/MAX3396E can withstand either the  $V_L$  or the  $V_{CC}$  supply floating while the other supply is applied. The device will not latch up in this state.

### Tri-State Output Mode

Connect EN to  $V_L$  or  $V_{CC}$  for normal operation. Drive EN low to force the MAX3394E/MAX3395E/MAX3396E to a tri-state output mode. In tri-state output mode, all I/O lines are driven to a high-impedance state, and the pass-FET is disabled to prevent current flow between I/O lines. Tri-state output mode disables the internal pullup resistors on  $I/O V_{L-}$  and  $I/O V_{CC-}$ , and reduces supply current to  $3\mu\text{A}$  typ ( $V_{CC}$ ) and  $0.7\mu\text{A}$  typ ( $V_L$ ).

# MAX3394E/MAX3395E/ MAX3396E

## ±15kV ESD-Protected, High-Drive Current, Dual-/Quad-/Octal-Level Translators with Speed-Up Circuitry

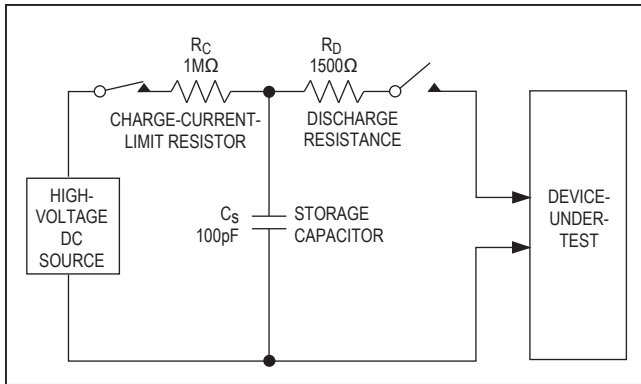

Figure 6a. Human Body ESD Test Model

The high-impedance state of the I/O lines during tri-state output mode facilitates use in multidrop networks. In tri-state output mode, do not exceed  $(V_L + 0.3V)$  on I/O  $V_{L\_}$  or  $(V_{CC} + 0.3V)$  on I/O  $V_{CC\_}$ .

### Thermal-Shutdown Protection

The MAX3394E/MAX3395E/MAX3396E are protected from thermal damage resulting from short-circuit faults. In the event of a short-circuit fault, when the junction temperature ( $T_J$ ) reaches +125°C, a thermal sensor forces the device into the tri-state output mode. When  $T_J$  drops below +115°C, normal operation resumes.

### ±15kV ESD Protection

As with all Maxim devices, ESD-protection structures are incorporated on all pins to protect against ESD encountered during handling and assembly. The I/O  $V_{CC\_}$  lines are further protected by advanced ESD structures to guard these pins from damage caused by ESD of up to ±15kV. Protection structures prevent damage caused by ESD events in normal operation, tri-state output mode, and when the device is unpowered. After arresting an ESD event, MAX3394E/MAX3395E/MAX3396E continue to function without latching up, whereas competing devices can enter a latched-up state and must be power cycled to restore functionality.

Several ESD testing standards exist for gauging the robustness of ESD structures. The ESD protection of the MAX3394E/MAX3395E/MAX3396E is characterized for the human body model (HBM). Figure 6a shows the model used to simulate an ESD event resulting from contact with the human body. The model consists of a 100pF storage capacitor that is charged to a high voltage then discharged through a 1.5kΩ resistor. Figure 6b shows the current waveform when the storage capacitor is discharged into a low impedance.

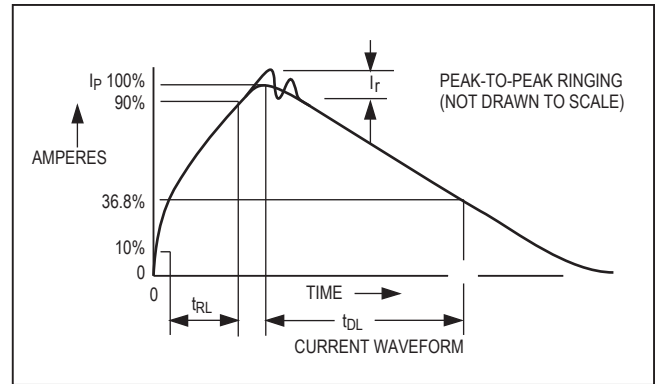

Figure 6b. HBM Discharge Current Waveform

To ensure full ±15kV ESD protection, bypass  $V_{CC}$  to ground with a 0.1μF ceramic capacitor and an additional 1μF ceramic capacitor as close to the device as possible.

### ESD Test Conditions

ESD performance depends on a variety of conditions. Contact Maxim for a reliability report documenting test setup, methodology, and results.

## Applications Information

### Power-Supply Decoupling

Bypass  $V_L$  and  $V_{CC}$  to ground with 0.1μF ceramic capacitors. To ensure full ±15kV ESD protection, bypass  $V_{CC}$  to ground with an additional 1μF or greater ceramic capacitor. Place all capacitors as close to the device as possible.

### Open-Drain Mode vs. Push-Pull Mode

The MAX3394E/MAX3395E/MAX3396E are compatible with push-pull (active) and open-drain drivers. For push-pull operation, maximum data rate is guaranteed to 6Mbps. For open-drain applications, the MAX3394E/MAX3395E/MAX3396E include internal pullup resistors and slew-rate enhancement circuitry, providing a maximum data rate of 1Mbps. External pullup resistors can be added to increase data rate when the bus is loaded by high capacitance. (See the *Use of External Pullup Resistors* section.)

### Serial-Interface Level Translation

The MAX3395E provides level translation on four I/O lines, making it an ideal device for multivoltage I<sup>2</sup>C, MICROWIRE, and SPI serial interfaces.

### Use of External Pullup Resistors

The MAX3394E/MAX3395E/MAX3396E include internal 10kΩ pullup resistors. During a low-to-high logic transition, the internal pullup resistors charge the bus capaci-

## Functional Diagram

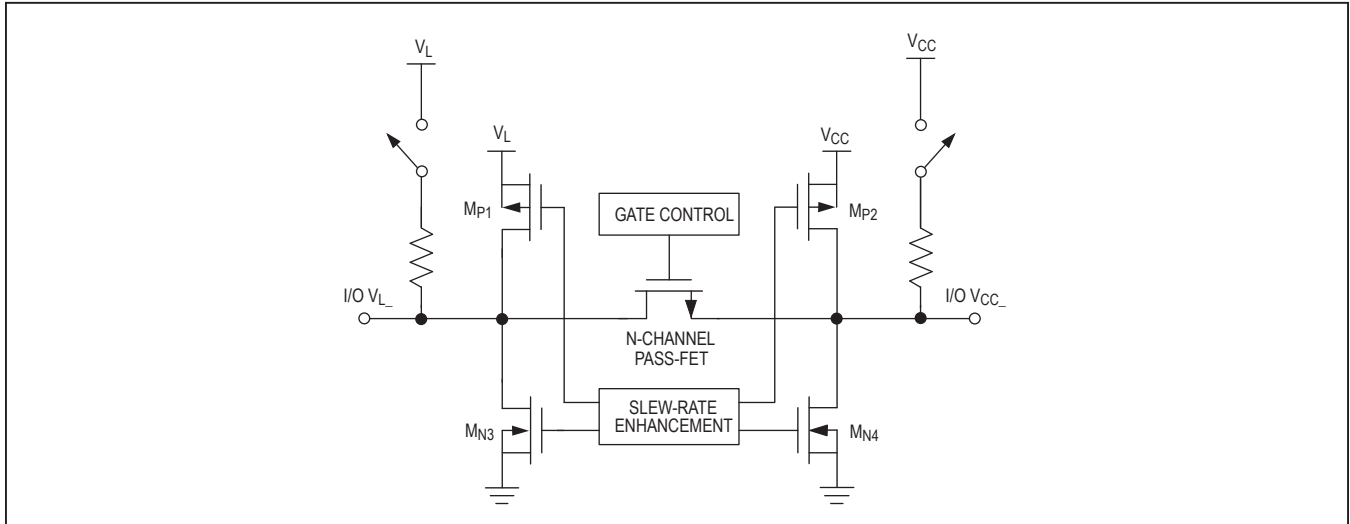

## Typical Operating Circuit

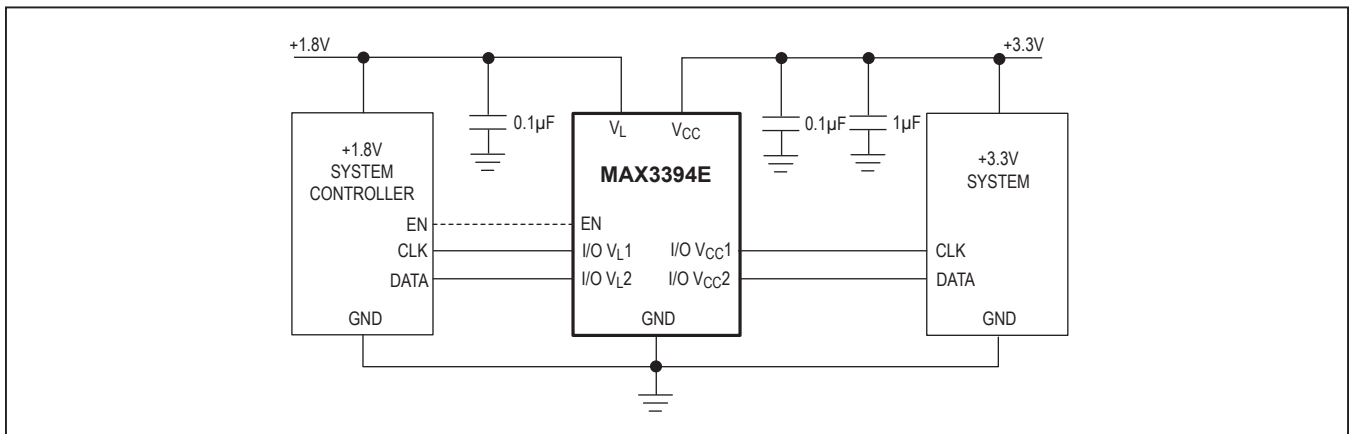

tance with a characteristic RC charging waveform. When the low-to-high transition threshold ( $V_{CC-TH}$  or  $V_{LTH}$ ) is reached, the rise time accelerators switch on, sourcing 15mA to fully charge the bus capacitance. External pullup resistors reduce the time needed to reach the low-to-high transition threshold, thereby increasing the data rate. In the logic-low state however, external pullup resistors increase the DC current through the internal pass-FET, increasing the output voltage of the device.

### Smart-Card Interface

The MAX3395E provides level translation for Class A, B, and C smart cards. When supply voltage  $V_{CC}$  is interrupted due to the disconnection of a smart card, the

device does not latch up. Normal operation resumes upon restoration of the  $V_{CC}$  supply voltage. The MAX3395E provides bidirectional level translation on four I/O lines, making it well suited for buffering and translating 4-wire serial interfaces.

## UCSP Applications Information

For the latest application details on UCSP construction, dimensions, tape carrier information, PCB techniques, bump-pad layout, and recommended reflow temperature profiles, as well as the latest information on reliability testing results, go to Maxim's web site at [www.maximintegrated.com/ucsp](http://www.maximintegrated.com/ucsp) to find the Application Note 1891: *Wafer-Level Packaging (WLP) and Its Applications*.

MAX3394E/MAX3395E/  
MAX3396E

±15kV ESD-Protected, High-Drive Current,  
Dual-/Quad-/Octal-Level Translators with  
Speed-Up Circuitry

Pin Configurations (continued)

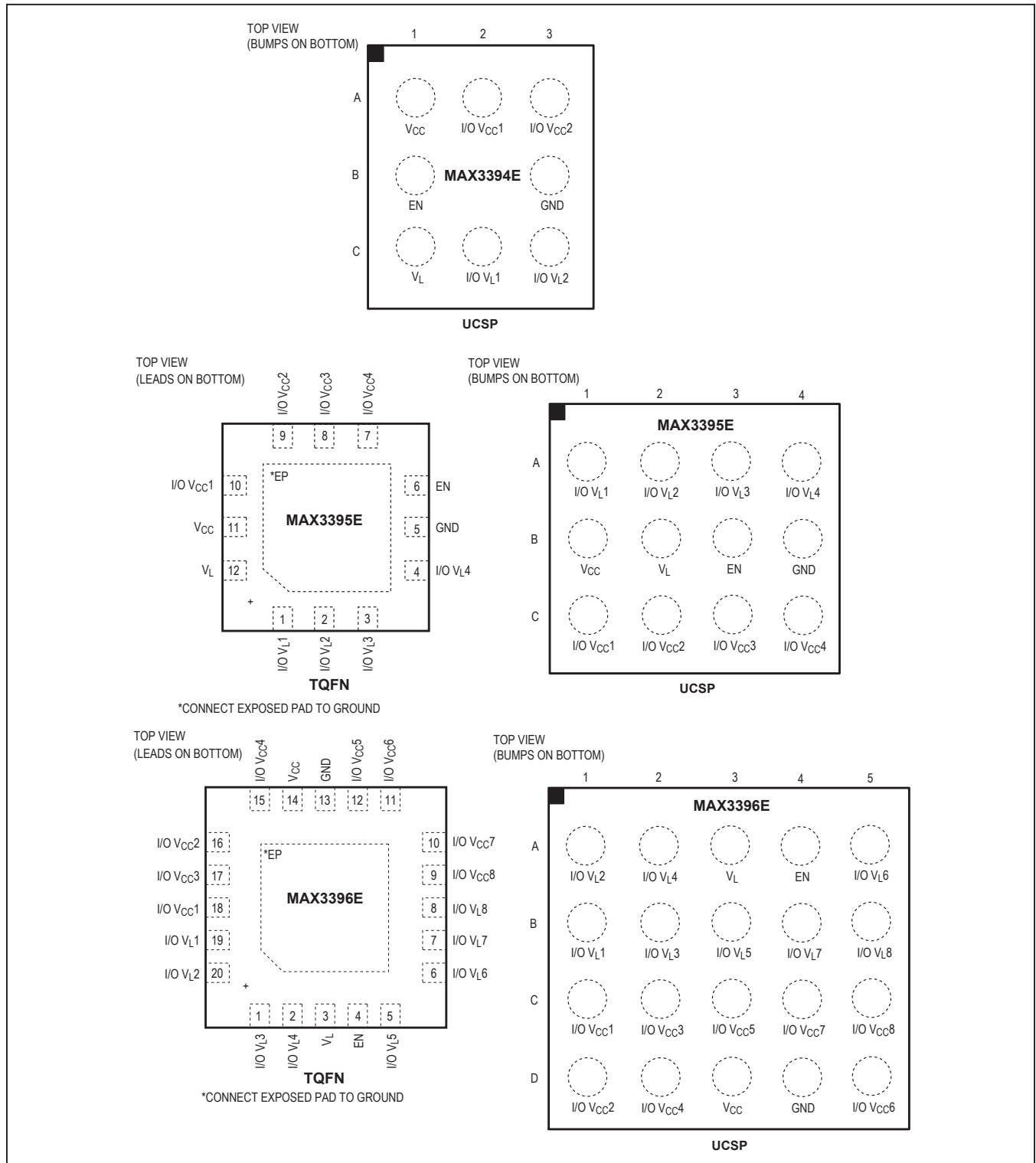

MAX3394E/MAX3395E/  
MAX3396E

±15kV ESD-Protected, High-Drive Current,  
Dual-/Quad-/Octal-Level Translators with  
Speed-Up Circuitry

### Selector Guide

PART	NUMBER OF TRANSLATORS	TOP MARK
MAX3394EETA+T	2	APE
MAX3394EEBL+T	2	AEZ
MAX3395EETC+	4	AAFZ
MAX3395EEBC+T	4	ACO
MAX3396EEBP+T	8	—
MAX3396EETP+	8	—

**Note:** All devices specified over the -40°C to +85°C operating range.

+Denotes lead(Pb)-free/RoHS-compliant package.

### Chip Information

PROCESS: BiCMOS

CONNECT EXPOSED PAD TO GND.

MAX3394E/MAX3395E/  
MAX3396E

±15kV ESD-Protected, High-Drive Current,  
Dual-/Quad-/Octal-Level Translators with  
Speed-Up Circuitry

Package Information

For the latest package outline information and land patterns (footprints), go to [www.maximintegrated.com/packages](http://www.maximintegrated.com/packages). Note that a "+", "#", or "-" in the package code indicates RoHS status only. Package drawings may show a different suffix character, but the drawing pertains to the package regardless of RoHS status.

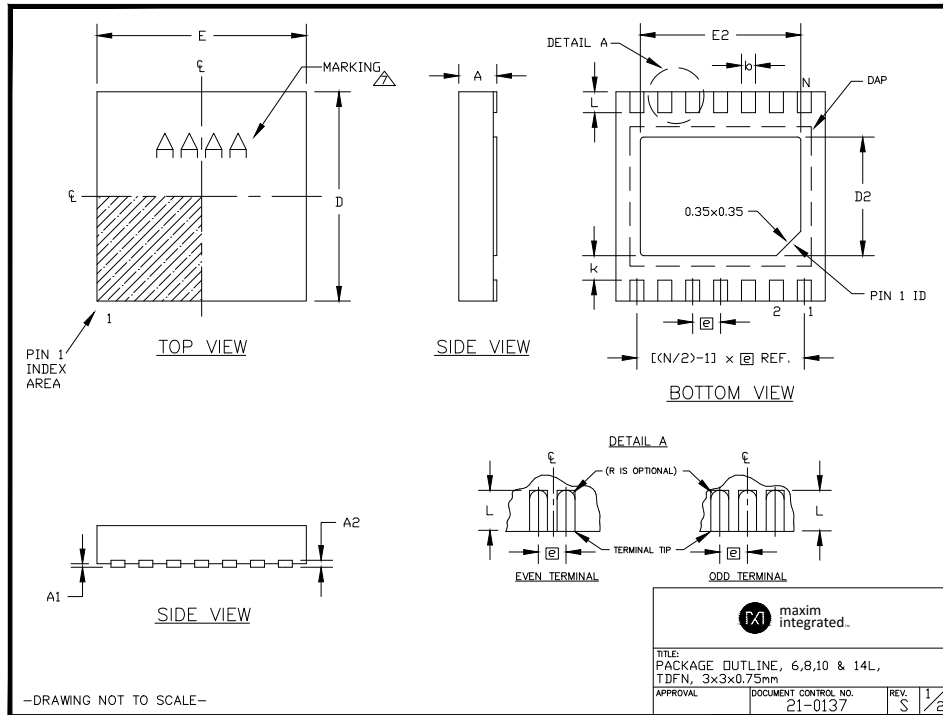

-DRAWING NOT TO SCALE-

COMMON DIMENSIONS			
SYMBOL	MIN	NOM	MAX
A	0.70	0.75	0.80
D	2.90	3.00	3.10
E	2.90	3.00	3.10
A1	0.00	0.025	0.05
L	0.20	0.30	0.40
k	0.25 MIN.		
A2	0.20 REF.		

PACKAGE VARIATIONS									
PKG. CODE	N	D2	E2	e	JEDEC SPEC	b	[(N/2)-1] x e		
T633-2	6	1.50±0.10	2.30±0.10	0.95 BSC	MO229 / WEEA	0.40±0.05	1.90 REF		
T633-2C	6	1.50±0.10	2.30±0.10	0.95 BSC	MO229 / WEEA	0.40±0.05	1.90 REF		
T633MK-1	6	1.50±0.10	2.30±0.10	0.95 BSC	MO229 / WEEA	0.40±0.05	1.90 REF		
T833-1F	8	1.50±0.10	2.30±0.10	0.65 BSC	MO229 / WEEC	0.30±0.05	1.95 REF		
T833-2	8	1.50±0.10	2.30±0.10	0.65 BSC	MO229 / WEEC	0.30±0.05	1.95 REF		
T833-2C	8	1.50±0.10	2.30±0.10	0.65 BSC	MO229 / WEEC	0.30±0.05	1.95 REF		
T833-3	8	1.50±0.10	2.30±0.10	0.65 BSC	MO229 / WEEC	0.30±0.05	1.95 REF		
T833-3C	8	1.50±0.10	2.30±0.10	0.65 BSC	MO229 / WEEC	0.30±0.05	1.95 REF		
T1033-1	10	1.50±0.10	2.30±0.10	0.50 BSC	MO229 / WEED-3	0.25±0.05	2.00 REF		
T1033-1C	10	1.50±0.10	2.30±0.10	0.50 BSC	MO229 / WEED-3	0.25±0.05	2.00 REF		
T1033MK-1	10	1.50±0.10	2.30±0.10	0.50 BSC	MO229 / WEED-3	0.25±0.05	2.00 REF		
T1033-2	10	1.50±0.10	2.30±0.10	0.50 BSC	MO229 / WEED-3	0.25±0.05	2.00 REF		
T1033-4	10	1.50±0.10	2.30±0.10	0.50 BSC	MO229 / WEED-3	0.25±0.05	2.00 REF		
T1433-1	14	1.70±0.10	2.30±0.10	0.40 BSC	----	0.20±0.05	2.40 REF		
T1433-2	14	1.70±0.10	2.30±0.10	0.40 BSC	----	0.20±0.05	2.40 REF		
T1433-2C	14	1.70±0.10	2.30±0.10	0.40 BSC	----	0.20±0.05	2.40 REF		
T1433-3F	14	1.70±0.10	2.30±0.10	0.40 BSC	----	0.20±0.05	2.40 REF		

NOTES:

- ALL DIMENSIONS ARE IN mm. ANGLES IN DEGREES.
- WARPAGE SHALL NOT EXCEED 0.10 mm.
- PACKAGE LENGTH/PACKAGE WIDTH ARE CONSIDERED AS SPECIAL CHARACTERISTIC(S).
- DRAWING CONFORMS TO JEDEC MO229, EXCEPT DIMENSIONS "D2" AND "E2", AND T1433-1 & T1433-2.
- N" IS THE TOTAL NUMBER OF LEADS.
- NUMBER OF LEADS SHOWN ARE FOR REFERENCE ONLY.
- MARKING IS FOR PACKAGE ORIENTATION REFERENCE ONLY.
- MATERIAL MUST BE COMPLIANT WITH MAXIM SPECIFICATION 10-0131 FOR SUBSTANCE CONTENT, MUST BE e6 ROHS COMPLIANT WITHOUT EXEMPTION AND PB-FREE.
- ALL DIMENSIONS APPLY TO BOTH LEADED (-) AND PbFREE (+) PKG. CODES.

-DRAWING NOT TO SCALE-

maxim integrated.  
TITLE: PACKAGE OUTLINE, 6,8,10 & 14L, TDFN, 3x3x0.75mm  
APPROVAL: DOCUMENT CONTROL NO. 21-0137 REV. S 1/2

maxim integrated.  
TITLE: PACKAGE OUTLINE, 6,8,10 & 14L, TDFN, 3x3x0.75mm  
APPROVAL: DOCUMENT CONTROL NO. 21-0137 REV. S 2/2

Package Information (continued)

For the latest package outline information and land patterns (footprints), go to [www.maximintegrated.com/packages](http://www.maximintegrated.com/packages). Note that a "+", "#", or "-" in the package code indicates RoHS status only. Package drawings may show a different suffix character, but the drawing pertains to the package regardless of RoHS status.

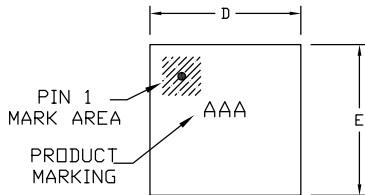

TOP VIEW

COMMON DIMENSIONS	
A	0.62±0.05-0.08
A1	0.29±0.02
A2	0.33 REF.
b	∅0.35±0.03
D1	1.00 BASIC
E1	1.00 BASIC
e	0.50 BASIC
SD	0.00 BASIC
SE	0.00 BASIC

PKG. CODE	VARIABLE DIMENSIONS		DEPOPULATED SOLDER BALLS
	D	E	
B9-1	1.52±0.05	1.52±0.05	NONE
B9-2	1.52±0.05	1.52±0.05	B2
B9-3	1.52±0.05	1.52±0.05	B1, B2, B3
B9-4	1.60±0.05	1.60±0.05	NONE
B9-5	1.60±0.05	1.60±0.05	B2
B9-6	1.60±0.05	1.60±0.05	B1, B2, B3
B9-7	1.52±0.05	1.52±0.05	A2, B1, B2, B3, C2
B9-8	1.98±0.05	1.75±0.05	B1, B2, B3

NOTES:

1. All dimensions in millimeters.
2. Outer dimension (D & E) is defined by center lines between scribe lines.
3. Marking shown is for package orientation reference only. Number of characters and lines vary per product.
4. All dimensions are applicable to Leaded (-), PbFree (+), and MaxFilm parts/pkg codes.

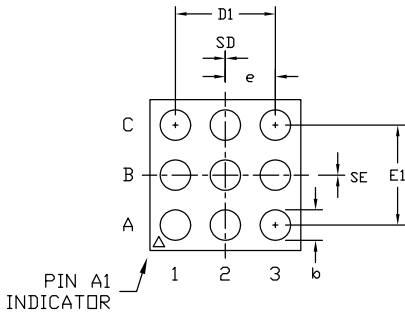

BOTTOM VIEW

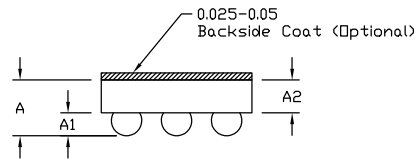

SIDE VIEW

-DRAWING NOT TO SCALE-



TITLE:  
PACKAGE OUTLINE,  
9 BUMPS, 3X3 ARRAY, UCSP (B) PKG.

APPROVAL	DOCUMENT CONTROL NO. 21-0093	REV. M	1/1
----------	---------------------------------	-----------	-----

MAX3394E/MAX3395E/  
MAX3396E

±15kV ESD-Protected, High-Drive Current,  
Dual-/Quad-/Octal-Level Translators with  
Speed-Up Circuitry

Package Information (continued)

For the latest package outline information and land patterns (footprints), go to [www.maximintegrated.com/packages](http://www.maximintegrated.com/packages). Note that a "+", "#", or "-" in the package code indicates RoHS status only. Package drawings may show a different suffix character, but the drawing pertains to the package regardless of RoHS status.

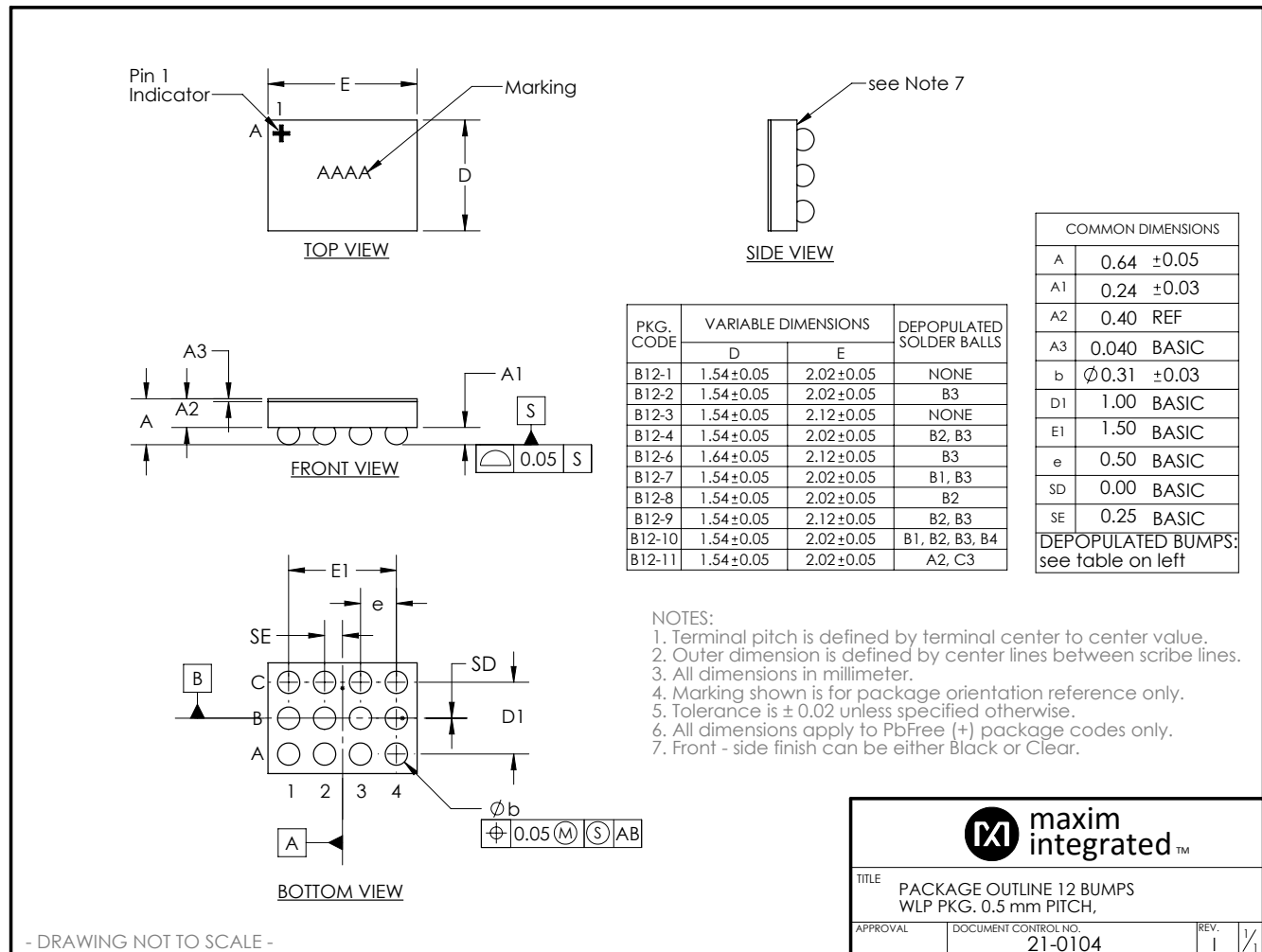

**maxim integrated™**

TITLE PACKAGE OUTLINE 12 BUMPS  
WLP PKG. 0.5 mm PITCH,

APPROVAL DOCUMENT CONTROL NO. 21-0104 REV. 1 1/1

MAX3394E/MAX3395E/  
MAX3396E

±15kV ESD-Protected, High-Drive Current,  
Dual-/Quad-/Octal-Level Translators with  
Speed-Up Circuitry

Package Information (continued)

For the latest package outline information and land patterns (footprints), go to [www.maximintegrated.com/packages](http://www.maximintegrated.com/packages). Note that a "+", "#", or "-" in the package code indicates RoHS status only. Package drawings may show a different suffix character, but the drawing pertains to the package regardless of RoHS status.

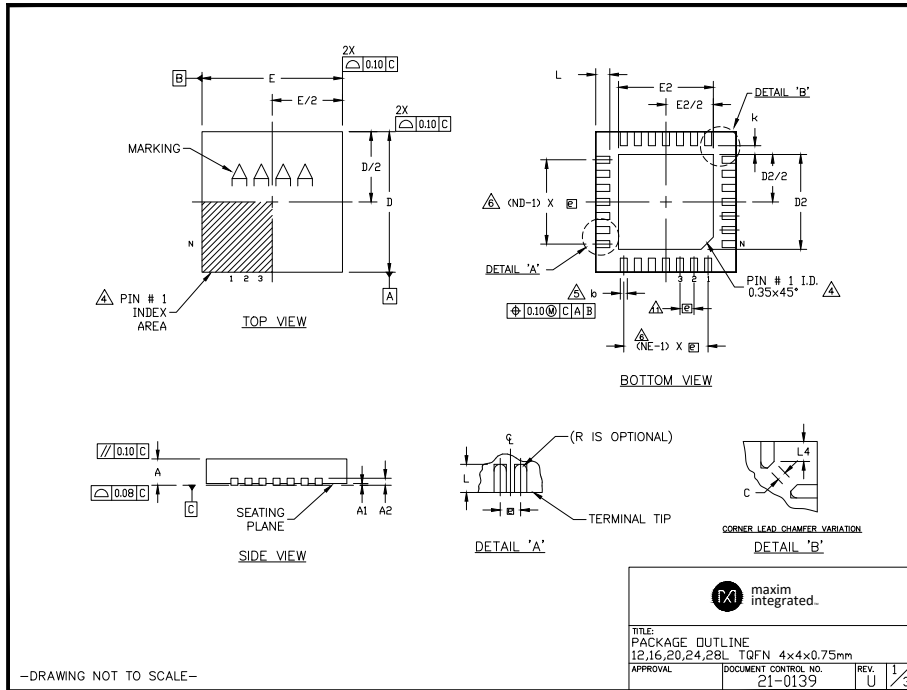

COMMON DIMENSIONS															
PKG	12L 4x4			16L 4x4			20L 4x4			24L 4x4			28L 4x4		
REF.	MIN.	NDM.	MAX.	MIN.	NDM.	MAX.	MIN.	NDM.	MAX.	MIN.	NDM.	MAX.	MIN.	NDM.	MAX.
A	0.70	0.75	0.80	0.70	0.75	0.80	0.70	0.75	0.80	0.70	0.75	0.80	0.70	0.75	0.80
A1	0.0	0.02	0.05	0.0	0.02	0.05	0.0	0.02	0.05	0.0	0.02	0.05	0.0	0.02	0.05
A2	0.20 REF.			0.20 REF.			0.20 REF.			0.20 REF.			0.20 REF.		
b	0.25	0.30	0.35	0.25	0.30	0.35	0.20	0.25	0.30	0.18	0.23	0.30	0.15	0.20	0.25
D	3.90	4.00	4.10	3.90	4.00	4.10	3.90	4.00	4.10	3.90	4.00	4.10	3.90	4.00	4.10
E	3.90	4.00	4.10	3.90	4.00	4.10	3.90	4.00	4.10	3.90	4.00	4.10	3.90	4.00	4.10
e	0.80 BSC.			0.85 BSC.			0.90 BSC.			0.90 BSC.			0.90 BSC.		
k	0.25	-	-	0.25	-	-	0.25	-	-	0.25	-	-	0.25	-	-
N	12			16			20			24			28		
ND	3			4			5			6			7		
NE	3			4			5			6			7		
JESD6C VOP	WGGB			WGGC			WGGD-1			WGGD-2			WGGE		

NOTES:

- DIMENSIONING & TOLERANCING CONFORM TO ASME Y14.5M-2009.
- ALL DIMENSIONS ARE IN MILLIMETERS. ANGLES ARE IN DEGREES.
- N IS THE TOTAL NUMBER OF TERMINALS.
- THE TERMINAL #1 IDENTIFIER AND TERMINAL NUMBERING CONVENTION SHALL CONFORM TO JEDEC 95-1 SPP-012. DETAILS OF TERMINAL #1 IDENTIFIER ARE OPTIONAL, BUT MUST BE LOCATED WITHIN THE ZONE INDICATED. THE TERMINAL #1 IDENTIFIER MAY BE EITHER A MOLD OR MARKED FEATURE.
- DIMENSION b APPLIES TO METALLIZED TERMINAL AND IS MEASURED BETWEEN 0.25mm AND 0.30mm FROM TERMINAL TIP.
- ND AND NE REFER TO THE NUMBER OF TERMINALS ON EACH D AND E SIDE RESPECTIVELY.
- DEPOPULATION IS POSSIBLE IN A SYMMETRICAL FASHION.
- DRAWING CONFORMS TO JEDEC M0220, EXCEPT FOR T2444-3, T2444-4 AND T2844-1.
- MARKING IS FOR PACKAGE ORIENTATION REFERENCE ONLY.
- WARPAGE SHALL NOT EXCEED 0.10mm.
- LEAD CENTERLINES TO BE AT TRUE POSITION AS DEFINED BY BASIC DIMENSION 'e', ±0.05.
- NUMBER OF LEADS SHOWN ARE FOR REFERENCE ONLY.
- MATERIAL MUST COMPLY WITH BANNED AND RESTRICTED SUBSTANCES SPEC # 10-0131.
- ALL DIMENSIONS ARE THE SAME FOR LEADED (-) & PBFREE (+) PACKAGE CODES.

maxim integrated.

TITLE: PACKAGE OUTLINE  
12,16,20,24,28L TQFN 4x4x0.75mm  
APPROVAL: DOCUMENT CONTROL NO. 21-0139 REV. U 2/3

-DRAWING NOT TO SCALE-

MAX3394E/MAX3395E/  
MAX3396E

±15kV ESD-Protected, High-Drive Current,  
Dual-/Quad-/Octal-Level Translators with  
Speed-Up Circuitry

Package Information (continued)

For the latest package outline information and land patterns (footprints), go to [www.maximintegrated.com/packages](http://www.maximintegrated.com/packages). Note that a “+”, “#”, or “-” in the package code indicates RoHS status only. Package drawings may show a different suffix character, but the drawing pertains to the package regardless of RoHS status.

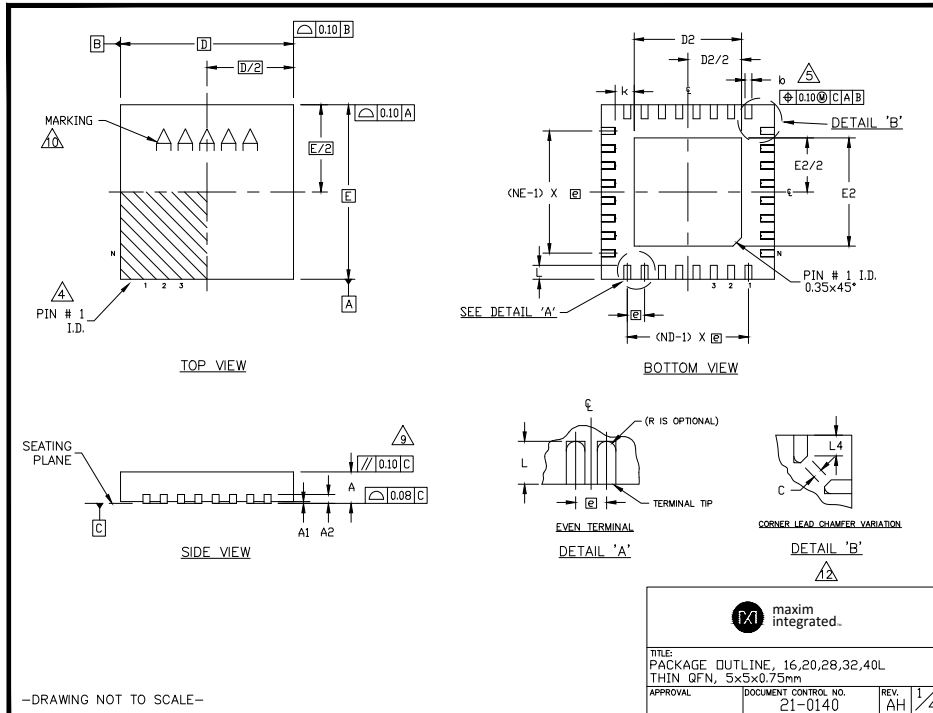

—DRAWING NOT TO SCALE—

maxim integrated.

TITLE: PACKAGE OUTLINE, 16,20,28,32,40L  
THIN QFN, 5x5x0.75mm

APPROVAL: DOCUMENT CONTROL NO. 21-0140 REV. AH 1/4

PKG. SYMBOL	COMMON DIMENSIONS														
	16L 5x5			20L 5x5			28L 5x5			32L 5x5			40L 5x5		
	MIN.	NDM.	MAX.	MIN.	NDM.	MAX.	MIN.	NDM.	MAX.	MIN.	NDM.	MAX.	MIN.	NDM.	MAX.
A	0.70	0.75	0.80	0.70	0.75	0.80	0.70	0.75	0.80	0.70	0.75	0.80	0.70	0.75	0.80
A1	0	0.02	0.05	0	0.02	0.05	0	0.02	0.05	0	0.02	0.05	0	0.02	0.05
A2	0.20 REF.			0.20 REF.			0.20 REF.			0.20 REF.			0.20 REF.		
b	0.25	0.30	0.35	0.25	0.30	0.35	0.20	0.25	0.30	0.20	0.25	0.30	0.15	0.20	0.25
D	5.00 BSC			5.00 BSC			5.00 BSC			5.00 BSC			5.00 BSC		
E	5.00 BSC			5.00 BSC			5.00 BSC			5.00 BSC			5.00 BSC		
e	0.80 BSC.			0.65 BSC.			0.50 BSC.			0.50 BSC.			0.40 BSC.		
k	0.25	-	-	0.25	-	-	0.25	-	-	0.25	-	-	0.25	-	-
L	0.30	0.40	0.50	0.45	0.55	0.65	0.45	0.55	0.65	0.30	0.40	0.50	0.30	0.40	0.50
N	16			20			28			32			40		
ND	4			5			7			8			10		
NE	4			5			7			8			10		
JEDEC	WHHB			WHHC			WHHD-1			WHHD-2			-----		

PKG. CODES	DIMENSION VARIATION											
	D2			E2			L					
	MIN.	NDM.	MAX.	MIN.	NDM.	MAX.	MIN.	NDM.	MAX.	MIN.	NDM.	MAX.
T1655-2	3.00	3.10	3.20	3.00	3.10	3.20	---	---	---	---	---	---
T1655-2C	3.00	3.10	3.20	3.00	3.10	3.20	---	---	---	---	---	---
T1655-3	3.00	3.10	3.20	3.00	3.10	3.20	---	---	---	---	---	---
T1655-3C	3.00	3.10	3.20	3.00	3.10	3.20	---	---	---	---	---	---
T1655-4	2.19	2.29	2.39	2.19	2.29	2.39	---	---	---	---	---	---
T1655-4C	2.19	2.29	2.39	2.19	2.29	2.39	---	---	---	---	---	---
T1655N-1	3.00	3.10	3.20	3.00	3.10	3.20	---	---	---	---	---	---
T2055-3	3.00	3.10	3.20	3.00	3.10	3.20	---	---	---	---	---	---
T2055M-3	3.00	3.10	3.20	3.00	3.10	3.20	---	---	---	---	---	---
T2055-4	3.00	3.10	3.20	3.00	3.10	3.20	---	---	---	---	---	---
T2055-4C	3.00	3.10	3.20	3.00	3.10	3.20	---	---	---	---	---	---
T2055-5	3.15	3.25	3.35	3.15	3.25	3.35	0.40	0.40	0.40	0.40	0.40	0.40
T2055-5C	3.15	3.25	3.35	3.15	3.25	3.35	0.40	0.40	0.40	0.40	0.40	0.40
T2055MN-5	3.15	3.25	3.35	3.15	3.25	3.35	0.40	0.40	0.40	0.40	0.40	0.40
T2055-6C	3.15	3.25	3.35	3.15	3.25	3.35	0.40	0.40	0.40	0.40	0.40	0.40
T2855-3	3.15	3.25	3.35	3.15	3.25	3.35	---	---	---	---	---	---
T2855-3C	3.15	3.25	3.35	3.15	3.25	3.35	---	---	---	---	---	---
T2855-4	2.60	2.70	2.80	2.60	2.70	2.80	---	---	---	---	---	---
T2855-4C	2.60	2.70	2.80	2.60	2.70	2.80	---	---	---	---	---	---
T2855-5	2.60	2.70	2.80	2.60	2.70	2.80	---	---	---	---	---	---
T2855-5C	2.60	2.70	2.80	2.60	2.70	2.80	---	---	---	---	---	---
T2855M-5	2.60	2.70	2.80	2.60	2.70	2.80	---	---	---	---	---	---
T2855-6	3.15	3.25	3.35	3.15	3.25	3.35	---	---	---	---	---	---
T2855-6C	3.15	3.25	3.35	3.15	3.25	3.35	---	---	---	---	---	---
T2855-7	2.60	2.70	2.80	2.60	2.70	2.80	---	---	---	---	---	---
T2855-7C	2.60	2.70	2.80	2.60	2.70	2.80	---	---	---	---	---	---
T2855-8	3.15	3.25	3.35	3.15	3.25	3.35	0.40	0.40	0.40	0.40	0.40	0.40
T2855-8C	3.15	3.25	3.35	3.15	3.25	3.35	0.40	0.40	0.40	0.40	0.40	0.40
T2855MK-8	3.15	3.25	3.35	3.15	3.25	3.35	0.40	0.40	0.40	0.40	0.40	0.40
T2855N-1	3.15	3.25	3.35	3.15	3.25	3.35	---	---	---	---	---	---

—DRAWING NOT TO SCALE—

maxim integrated.

TITLE: PACKAGE OUTLINE, 16,20,28,32,40L  
THIN QFN, 5x5x0.75mm

APPROVAL: DOCUMENT CONTROL NO. 21-0140 REV. AH 2/4

**Package Information (continued)**

For the latest package outline information and land patterns (footprints), go to [www.maximintegrated.com/packages](http://www.maximintegrated.com/packages). Note that a "+", "#", or "-" in the package code indicates RoHS status only. Package drawings may show a different suffix character, but the drawing pertains to the package regardless of RoHS status.

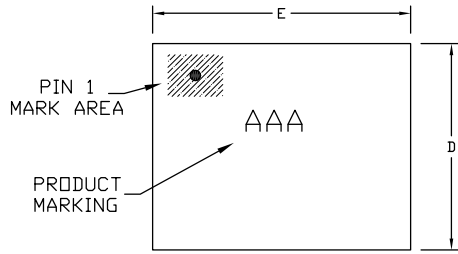

**TOP VIEW**

COMMON DIMENSIONS	
A	0.62±0.05-0.08
A1	0.29±0.02
A2	0.33 REF.
b	∅0.35±0.03
D1	1.50 BASIC
E1	2.00 BASIC
e	0.50 BASIC
SD	0.25 BASIC
SE	0.00 BASIC

PKG. CODE	VARIABLE DIMENSIONS		DEPOPULATED SOLDER BALLS
	D	E	
B20-1	2.03±0.08	2.54±0.08	NONE
B20-2	2.03±0.08	2.54±0.08	B2, B3, B4
B20-4	2.03±0.08	2.54±0.08	B2, B3, B4, C2, C4
B20-5	2.03±0.08	2.54±0.08	B2, B3, B4, C2, C3, C4
B20-6	2.16±0.08	2.54±0.08	B2, B3, B4
B20-7	2.03±0.08	2.54±0.08	B3, C3
B20-8	2.03±0.08	2.54±0.08	B2, B4, C2, C4

**NOTES:**

1. All dimensions in millimeters.
2. Outer dimension (D & E) is defined by center lines between scribe lines.
3. Marking shown is for package orientation reference only. Number of characters and lines vary per product.
4. All dimensions are applicable to Leaded (-), PbFree (+), and MaxFilm parts/pkg codes.

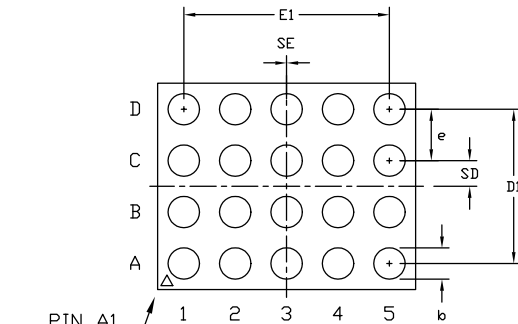

**BOTTOM VIEW**

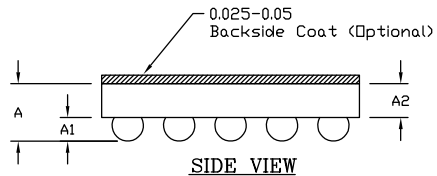

**SIDE VIEW**

-DRAWING NOT TO SCALE-

<b>MAXIM</b>		
TITLE: PACKAGE OUTLINE, 20 BUMPS, 5X4 ARRAY, UCSP (B) PKG.		
APPROVAL	DOCUMENT CONTROL NO. 21-0095	REV. K 1/1

MAX3394E/MAX3395E/  
MAX3396E

±15kV ESD-Protected, High-Drive Current,  
Dual-/Quad-/Octal-Level Translators with  
Speed-Up Circuitry

REVISION NUMBER	REVISION DATE	DESCRIPTION	PAGES CHANGED
3	7/17	Updated <i>Electrical Characteristics</i> table	2-3

For pricing, delivery, and ordering information, please contact Maxim Direct at 1-888-629-4642, or visit Maxim Integrated's website at [www.maximintegrated.com](http://www.maximintegrated.com).

*Maxim Integrated cannot assume responsibility for use of any circuitry other than circuitry entirely embodied in a Maxim Integrated product. No circuit patent licenses are implied. Maxim Integrated reserves the right to change the circuitry and specifications without notice at any time. The parametric values (min and max limits) shown in the Electrical Characteristics table are guaranteed. Other parametric values quoted in this data sheet are provided for guidance.*

## Looking for pricing, stock, or lifecycle information?

Click below to explore more details on WIN SOURCE:

 [View MAX3394EETA+T on WIN SOURCE](#)

 [Maxim Integrated](#) Information

## Optimize Your Supply Chain with WIN SOURCE Solutions

-  Global Sourcing Solution
-  Obsolete Management
-  Cost Control Management
-  Shortage Management
-  Alternative Solution
-  Excess Inventory Management