



# MAX3372E–MAX3379E/ ±15kV ESD-Protected, 1µA, 16Mbps, Dual/Quad MAX3390E–MAX3393E Low-Voltage Level Translators in UCSP

## General Description

The MAX3372E–MAX3379E and MAX3390E–MAX3393E ±15kV ESD-protected level translators provide the level shifting necessary to allow data transfer in a multivoltage system. Externally applied voltages,  $V_{CC}$  and  $V_L$ , set the logic levels on either side of the device. A low-voltage logic signal present on the  $V_L$  side of the device appears as a high-voltage logic signal on the  $V_{CC}$  side of the device, and vice-versa. The MAX3374E/MAX3375E/MAX3376E/MAX3379E and MAX3390E–MAX3393E unidirectional level translators level shift data in one direction ( $V_L \rightarrow V_{CC}$  or  $V_{CC} \rightarrow V_L$ ) on any single data line. The MAX3372E/MAX3373E and MAX3377E/MAX3378E bidirectional level translators utilize a transmission-gate-based design (Figure 2) to allow data translation in either direction ( $V_L \leftrightarrow V_{CC}$ ) on any single data line. The MAX3372E–MAX3379E and MAX3390E–MAX3393E accept  $V_L$  from +1.2V to +5.5V and  $V_{CC}$  from +1.65V to +5.5V, making them ideal for data transfer between low-voltage ASICs/PLDs and higher voltage systems.

All devices in the MAX3372E–MAX3379E, MAX3390E–MAX3393E family feature a three-state output mode that reduces supply current to less than 1µA, thermal shortcircuit protection, and ±15kV ESD protection on the  $V_{CC}$  side for greater protection in applications that route signals externally. The MAX3372E/MAX3377E operate at a guaranteed data rate of 230kbps. Slew-rate limiting reduces EMI emissions in all 230kbps devices. The MAX3373E–MAX3376E/MAX3378E/MAX3379E and MAX3390E–MAX3393E operate at a guaranteed data rate of 8Mbps over the entire specified operating voltage range. Within specific voltage domains, higher data rates are possible. (See the *Timing Characteristics* table.)

The MAX3372E–MAX3376E are dual level shifters available in 3 x 3 UCSP™, 8-pin TDFN, and 8-pin SOT23-8 packages. The MAX3377E/MAX3378E/MAX3379E and MAX3390E–MAX3393E are quad level shifters available in 3 x 4 UCSP, 14-pin TDFN, and 14-pin TSSOP packages.

## Applications

- SPI, MICROWIRE, and I<sup>2</sup>C Level Translation
- Low-Voltage ASIC Level Translation
- Smart Card Readers
- Cell-Phone Cradles
- Portable POS Systems
- Portable Communication Devices
- Low-Cost Serial Interfaces
- Cell Phones
- GPS
- Telecommunications Equipment

## Features

- Logic-Level Translators Simplify Design by Enabling Data Transfer Between Lower and Higher Voltage Systems
- Operation Down to +1.2V on  $V_L$
- Guaranteed Data Rate Options
  - 230kbps
  - 8Mbps ( $+1.2V \leq V_L \leq V_{CC} \leq +5.5V$ )
  - 10Mbps ( $+1.2V \leq V_L \leq V_{CC} \leq +3.3V$ )
  - 16Mbps ( $+1.8V \leq V_L \leq V_{CC} \leq +2.5V$  and  $+2.5V \leq V_L \leq V_{CC} \leq +3.3V$ )
- Bidirectional Level Translation (MAX3372E/MAX3373E and MAX3377E/MAX3378E)
- Low Power Consumption Reduces Thermal Dissipation
- Quiescent Current (130µA typ)
- 1µA Supply Current in Three-State Output Mode
- Slew-Rate Limiting Lowers EMI
- Protection Features Increase System Reliability
- ±15kV ESD Protection on I/O  $V_{CC}$  Lines
- Thermal Short-Circuit Protection

*Ordering Information* continued at end of data sheet.  
*Selector Guide* appears at end of data sheet.

UCSP is a trademark of Maxim Integrated Products, Inc.

## Pin Configurations

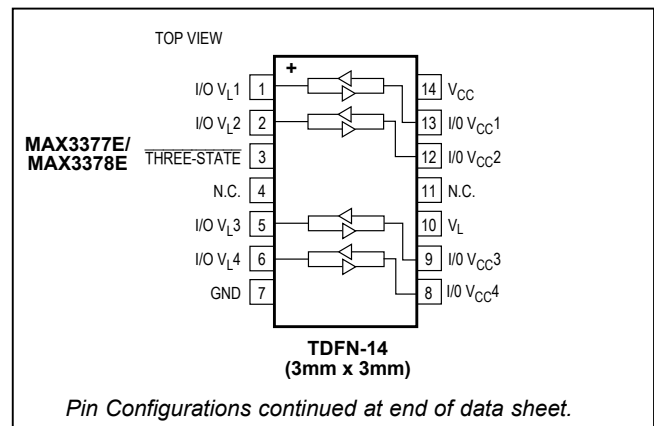

MAX3372E–MAX3379E/  
MAX3390E–MAX3393E

±15kV ESD-Protected, 1µA, 16Mbps, Dual/Quad  
Low-Voltage Level Translators in UCSP

**Absolute Maximum Ratings**

(All voltages referenced to GND.)

V <sub>CC</sub> .....	-0.3V to +6V
I/O V <sub>CC_</sub> .....	-0.3V to (V <sub>CC</sub> + 0.3V)
I/O V <sub>L</sub> .....	-0.3V to (V <sub>L</sub> + 0.3V)
THREE-STATE.....	-0.3V to (V <sub>L</sub> + 0.3V)
Short-Circuit Duration I/O V <sub>L</sub> , I/O V <sub>CC</sub> to GND.....	Continuous
Short-Circuit Duration I/O V <sub>L</sub> or I/O V <sub>CC</sub> to GND Driven from 40mA Source (except MAX3372E and MAX3377E).....	Continuous
Continuous Power Dissipation (T <sub>A</sub> = +70°C) 8-Pin SOT23 (derate 5.6mW/°C above +70°C).....	444.4mW

8-Pin TDFN (derate 18.5mW/°C above +70°C).....	1482mW
3 x 3 UCSP (derate 4.7mW/°C above +70°C).....	379mW
3 x 4 UCSP (derate 6.5mW/°C above +70°C).....	520mW
14-Pin TSSOP (derate 9.1mW/°C above +70°C).....	727mW
14-Pin TDFN (derate 18.5mW/°C above +70°C).....	1482mW
Operating Temperature Range.....	-40°C to +85°C
Storage Temperature Range.....	-65°C to +150°C
Lead Temperature (soldering, 10s).....	+300°C
Soldering Temperature (reflow).....	+260°C

Stresses beyond those listed under "Absolute Maximum Ratings" may cause permanent damage to the device. These are stress ratings only, and functional operation of the device at these or any other conditions beyond those indicated in the operational sections of the specifications is not implied. Exposure to absolute maximum rating conditions for extended periods may affect device reliability.

**Electrical Characteristics**

(V<sub>CC</sub> = +1.65V to +5.5V, V<sub>L</sub> = +1.2V to (V<sub>CC</sub> + 0.3V), GND = 0, I/O V<sub>L\_</sub> and I/O V<sub>CC\_</sub> unconnected, T<sub>A</sub> = T<sub>MIN</sub> to T<sub>MAX</sub>, unless otherwise noted. Typical values are at V<sub>CC</sub> = +3.3V, V<sub>L</sub> = +1.8V, T<sub>A</sub> = +25°C.) (Notes 1, 2)

PARAMETER	SYMBOL	CONDITIONS	MIN	TYP	MAX	UNITS
<b>POWER SUPPLIES</b>						
V <sub>L</sub> Supply Range	V <sub>L</sub>		1.2		5.5	V
V <sub>CC</sub> Supply Range	V <sub>CC</sub>		1.65		5.50	V
Supply Current from V <sub>CC</sub>	I <sub>QVCC</sub>			130	300	µA
Supply Current from V <sub>L</sub>	I <sub>QVL</sub>			16	100	µA
V <sub>CC</sub> Three-State Output Mode Supply Current	I <sub>THREE-STATE-VCC</sub>	T <sub>A</sub> = +25°C, $\overline{\text{THREE-STATE}} = \text{GND}$		0.03	1	µA
V <sub>L</sub> Three-State Output Mode Supply Current	I <sub>THREE-STATE-VL</sub>	T <sub>A</sub> = +25°C, $\overline{\text{THREE-STATE}} = \text{GND}$		0.03	1	µA
Three-State Output Mode Leakage Current I/O V <sub>L_</sub> and I/O V <sub>CC_</sub>	I <sub>THREE-STATE-LKG</sub>	T <sub>A</sub> = +25°C, $\overline{\text{THREE-STATE}} = \text{GND}$		0.02	1	µA
THREE-STATE Pin Input Leakage		T <sub>A</sub> = +25°C		0.02	1	µA
<b>ESD PROTECTION</b>						
I/O V <sub>CC</sub> (Note 3)		IEC 1000-4-2 Air-Gap Discharge	±8			kV
		IEC 1000-4-2 Contact Discharge	±8			
		Human Body Model	±15			
<b>LOGIC-LEVEL THRESHOLDS (MAX3372E/MAX3377E)</b>						
I/O V <sub>L_</sub> Input-Voltage High	V <sub>IHL</sub>		V <sub>L</sub> - 0.2			V
I/O V <sub>L_</sub> Input-Voltage Low	V <sub>ILL</sub>				0.15	V

MAX3372E–MAX3379E/  
MAX3390E–MAX3393E

±15kV ESD-Protected, 1µA, 16Mbps, Dual/Quad  
Low-Voltage Level Translators in UCSP

Electrical Characteristics (continued)

( $V_{CC} = +1.65V$  to  $+5.5V$ ,  $V_L = +1.2V$  to  $(V_{CC} + 0.3V)$ ,  $GND = 0$ , I/O  $V_L$  and I/O  $V_{CC}$  unconnected,  $T_A = T_{MIN}$  to  $T_{MAX}$ , unless otherwise noted. Typical values are at  $V_{CC} = +3.3V$ ,  $V_L = +1.8V$ ,  $T_A = +25^\circ C$ .) (Notes 1, 2)

PARAMETER	SYMBOL	CONDITIONS	MIN	TYP	MAX	UNITS
I/O $V_{CC}$ Input-Voltage High	$V_{IHC}$		$V_{CC} - 0.4$			V
I/O $V_{CC}$ Input-Voltage Low	$V_{ILC}$				0.15	V
I/O $V_L$ Output-Voltage High	$V_{OHL}$	I/O $V_L$ source current = $20\mu A$ , I/O $V_{CC} \geq V_{CC} - 0.4V$	$0.67 \times V_L$			V
I/O $V_L$ Output-Voltage Low	$V_{OLL}$	I/O $V_L$ sink current = $20\mu A$ , I/O $V_{CC} \leq 0.15V$			0.4	V
I/O $V_{CC}$ Output-Voltage High	$V_{OHC}$	I/O $V_{CC}$ source current = $20\mu A$ , I/O $V_L \geq V_L - 0.2V$	$0.67 \times V_{CC}$			V
I/O $V_{CC}$ Output-Voltage Low	$V_{OLC}$	I/O $V_{CC}$ sink current = $20\mu A$ , I/O $V_L \leq 0.15V$			0.4	V
THREE-STATE Input-Voltage High	$V_{IL-THREE-STATE}$		$V_L - 0.2$			V
THREE-STATE Input-Voltage Low	$V_{IL-THREE-STATE}$				0.15	V
<b>LOGIC-LEVEL THRESHOLDS (MAX3373E–MAX3376E/MAX3378E/MAX3379E and MAX3390E–MAX3393E)</b>						
I/O $V_L$ Input-Voltage High	$V_{IHL}$		$V_L - 0.2$			V
I/O $V_L$ Input-Voltage Low	$V_{ILL}$				0.15	V
I/O $V_{CC}$ Input-Voltage High	$V_{IHC}$		$V_{CC} - 0.4$			V
I/O $V_{CC}$ Input-Voltage Low	$V_{ILC}$				0.15	V
I/O $V_L$ Output-Voltage High	$V_{OHL}$	I/O $V_L$ source current = $20\mu A$ , I/O $V_{CC} \geq V_{CC} - 0.4V$	$0.67 \times V_L$			V
I/O $V_L$ Output-Voltage Low	$V_{OLL}$	I/O $V_L$ sink current = $1mA$ , I/O $V_{CC} \leq 0.15V$			0.4	V
I/O $V_{CC}$ Output-Voltage High	$V_{OHC}$	I/O $V_{CC}$ source current = $20\mu A$ , I/O $V_L \geq V_L - 0.2V$	$0.67 \times V_{CC}$			V
I/O $V_{CC}$ Output-Voltage Low	$V_{OLC}$	I/O $V_{CC}$ sink current = $1mA$ , I/O $V_L \leq 0.15V$			0.4	V
THREE-STATE Input-Voltage High	$V_{IH-THREE-STATE}$		$V_L - 0.2$			V
THREE-STATE Input-Voltage Low	$V_{IL-THREE-STATE}$				0.15	V

MAX3372E–MAX3379E/  
MAX3390E–MAX3393E

±15kV ESD-Protected, 1µA, 16Mbps, Dual/Quad  
Low-Voltage Level Translators in UCSP

Timing Characteristics

(V<sub>CC</sub> = +1.65V to +5.5V, V<sub>L</sub> = +1.2V to (V<sub>CC</sub> + 0.3V), GND = 0, R<sub>LOAD</sub> = 1MΩ, I/O test signal of Figure 1, T<sub>A</sub> = T<sub>MIN</sub> to T<sub>MAX</sub>, unless otherwise noted. Typical values are at V<sub>CC</sub> = +3.3V, V<sub>L</sub> = +1.8V, T<sub>A</sub> = +25°C, unless otherwise noted.) (Notes 1, 2)

PARAMETER	SYMBOL	CONDITIONS	MIN	TYP	MAX	UNITS	
<b>MAX3372E/MAX3377E (C<sub>LOAD</sub> = 50pF)</b>							
I/O V <sub>CC</sub> _ Rise Time (Note 4)	t <sub>RVCC</sub>			1100		ns	
I/O V <sub>CC</sub> _ Fall Time (Note 5)	t <sub>FVCC</sub>			1000		ns	
I/O V <sub>L</sub> _ Rise Time (Note 4)	t <sub>RVL</sub>			600		ns	
I/O V <sub>L</sub> _ Fall Time (Note 5)	t <sub>FVL</sub>			1100		ns	
Propagation Delay	I/O <sub>VL</sub> -V <sub>CC</sub>	Driving I/O V <sub>L</sub> _			1.6	µs	
	I/O <sub>VCC</sub> -V <sub>L</sub>	Driving I/O V <sub>CC</sub> _			1.6		
Channel-to-Channel Skew	t <sub>SKEW</sub>	Each translator equally loaded			500	ns	
Maximum Data Rate		C <sub>L</sub> = 25pF	230			kbps	
<b>MAX3373E–MAX3376E/MAX3378E/MAX3379E and MAX3390E–MAX3393E (C<sub>LOAD</sub> = 15pF, Driver Output Impedance ≤ 50Ω)</b>							
<b>+1.2V ≤ V<sub>L</sub> ≤ V<sub>CC</sub> ≤ +5.5V</b>							
I/O V <sub>CC</sub> _ Rise Time (Note 4)	t <sub>RVCC</sub>			7	25	ns	
		Open-drain driving		170	400		
I/O V <sub>CC</sub> _ Fall Time (Note 5)	t <sub>FVCC</sub>			6	37	ns	
		Open-drain driving		20	50		
I/O V <sub>L</sub> _ Rise Time (Note 4)	t <sub>RVL</sub>			8	30	ns	
		Open-drain driving		180	400		
I/O V <sub>L</sub> _ Fall Time (Note 5)	t <sub>LFV</sub>			3	30	ns	
		Open-drain driving		30	60		
Propagation Delay	I/O <sub>VL</sub> -V <sub>CC</sub>	Driving I/O V <sub>L</sub> _			5	ns	
			Open-drain driving		210		1000
	I/O <sub>VCC</sub> -V <sub>L</sub>	Driving I/O V <sub>CC</sub> _			4		30
			Open-drain driving		190		
Channel-to-Channel Skew	t <sub>SKEW</sub>	Each translator equally loaded			20	ns	
			Open-drain driving				50
Maximum Data Rate			8			Mbps	
		Open-drain driving	500			kbps	

MAX3372E–MAX3379E/  
MAX3390E–MAX3393E

±15kV ESD-Protected, 1µA, 16Mbps, Dual/Quad  
Low-Voltage Level Translators in UCSP

### Timing Characteristics (continued)

( $V_{CC} = +1.65V$  to  $+5.5V$ ,  $V_L = +1.2V$  to  $(V_{CC} + 0.3V)$ ,  $GND = 0$ ,  $R_{LOAD} = 1M\Omega$ , I/O test signal of Figure 1,  $T_A = T_{MIN}$  to  $T_{MAX}$ , unless otherwise noted. Typical values are at  $V_{CC} = +3.3V$ ,  $V_L = +1.8V$ ,  $T_A = +25^\circ C$ , unless otherwise noted.) (Notes 1, 2)

PARAMETER	SYMBOL	CONDITIONS	MIN	TYP	MAX	UNITS
<b>+1.2V ≤ V<sub>L</sub> ≤ V<sub>CC</sub> ≤ +3.3V</b>						
I/O V <sub>CC</sub> Rise Time (Note 4)	t <sub>RVCC</sub>				25	ns
I/O V <sub>CC</sub> Fall Time (Note 5)	t <sub>FVCC</sub>				30	ns
I/O V <sub>L</sub> Rise Time (Note 4)	t <sub>RVL</sub>				30	ns
I/O V <sub>L</sub> Fall Time (Note 5)	t <sub>FVL</sub>				30	ns
Propagation Delay	I/O <sub>VL-VCC</sub>	Driving I/O V <sub>L</sub>			20	ns
	I/O <sub>VCC-VL</sub>	Driving I/O V <sub>CC</sub>			20	
Channel-to-Channel Skew	t <sub>SKEW</sub>	Each translator equally loaded			10	ns
Maximum Data Rate			10			Mbps
<b>+2.5V ≤ V<sub>L</sub> ≤ V<sub>CC</sub> ≤ +3.3V</b>						
I/O V <sub>CC</sub> Rise Time (Note 4)	t <sub>RVCC</sub>				15	ns
I/O V <sub>CC</sub> Fall Time (Note 5)	t <sub>FVCC</sub>				15	ns
I/O V <sub>L</sub> Rise Time (Note 4)	t <sub>RVL</sub>				15	ns
I/O V <sub>L</sub> Fall Time (Note 5)	t <sub>FVL</sub>				15	ns
Propagation Delay	I/O <sub>VL-VCC</sub>	Driving I/O V <sub>L</sub>			15	ns
	I/O <sub>VCC-VL</sub>	Driving I/O V <sub>CC</sub>			15	
Channel-to-Channel Skew	t <sub>SKEW</sub>	Each translator equally loaded			10	ns
Maximum Data Rate			16			Mbps
<b>+1.8V ≤ V<sub>L</sub> ≤ V<sub>CC</sub> ≤ +2.5V</b>						
I/O V <sub>CC</sub> Rise Time (Note 4)	t <sub>RVCC</sub>				15	ns
I/O V <sub>CC</sub> Fall Time (Note 5)	t <sub>FVCC</sub>				15	ns
I/O V <sub>L</sub> Rise Time (Note 4)	t <sub>RVL</sub>				15	ns
I/O V <sub>L</sub> Fall Time (Note 5)	t <sub>FVL</sub>				15	ns
Propagation Delay	I/O <sub>VL-VCC</sub>	Driving I/O V <sub>L</sub>			15	ns
	I/O <sub>VCC-VL</sub>	Driving I/O V <sub>CC</sub>			15	
Channel-to-Channel Skew	t <sub>SKEW</sub>	Each translator equally loaded			10	ns
Maximum Data Rate			16			Mbps

**Note 1:** All units are 100% production tested at  $T_A = +25^\circ C$ . Limits over the operating temperature range are guaranteed by design and not production tested.

**Note 2:** For normal operation, ensure  $V_L < (V_{CC} + 0.3V)$ . During power-up,  $V_L > (V_{CC} + 0.3V)$  will not damage the device.

**Note 3:** To ensure maximum ESD protection, place a 1µF capacitor between  $V_{CC}$  and GND. See Applications Circuits.

**Note 4:** 10% to 90%

**Note 5:** 90% to 10%

### Typical Operating Characteristics

( $R_{LOAD} = 1M\Omega$ ,  $T_A = +25^\circ C$ , unless otherwise noted. All 230kbps TOCs apply to MAX3372E/MAX3377E only. All 8Mbps and 500kbps TOCs apply to MAX3373E–MAX3376E/MAX3378E/MAX3379E and MAX3390E–MAX3393E only.)

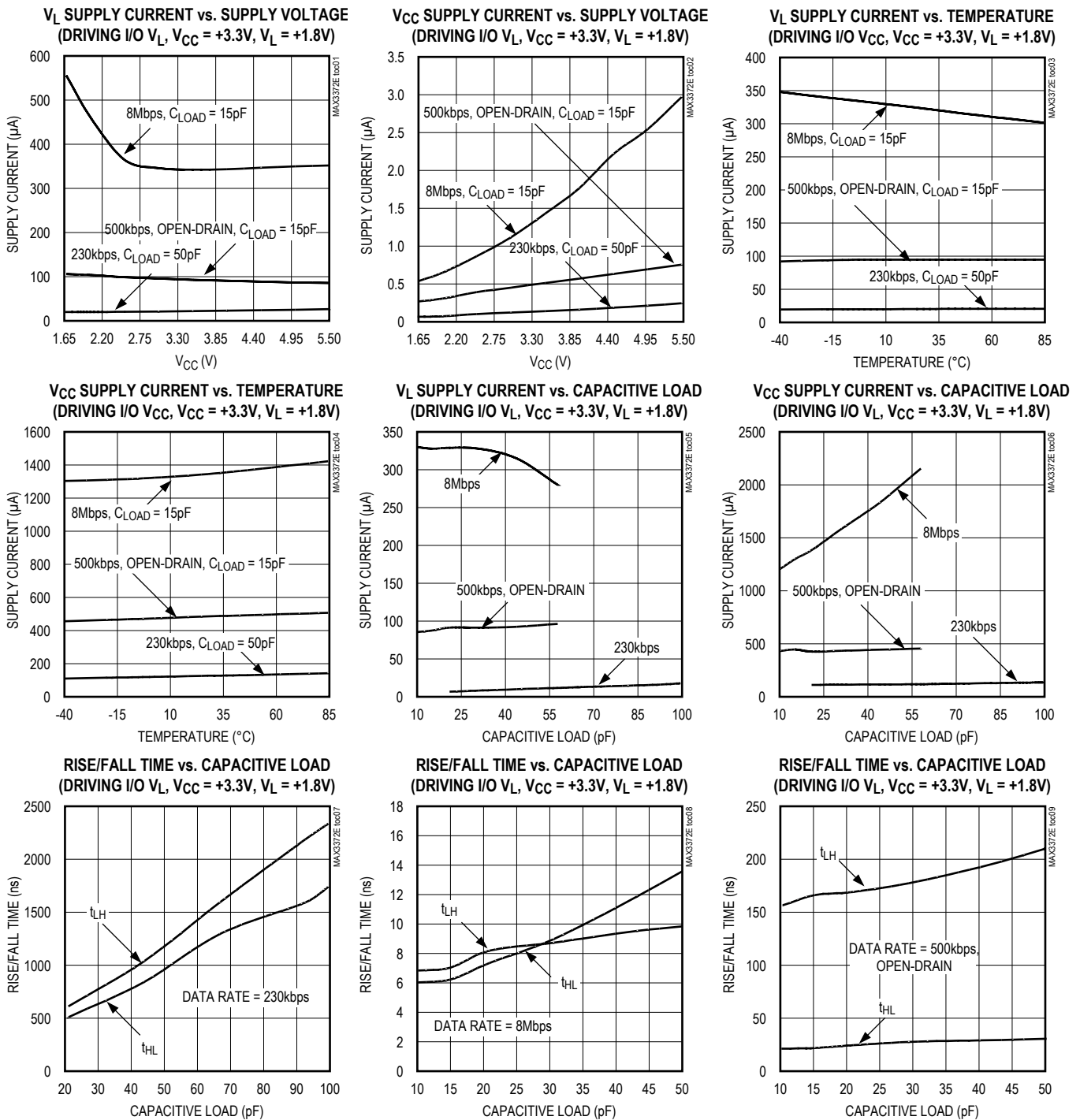

Typical Operating Characteristics (continued)

( $R_{LOAD} = 1M\Omega$ ,  $T_A = +25^\circ C$ , unless otherwise noted. All 230kbps TOCs apply to MAX3372E/MAX3377E only. All 8Mbps and 500kbps TOCs apply to MAX3373E–MAX3376E/MAX3378E/MAX3379E and MAX3390E–MAX3393E only.)

PROPAGATION DELAY vs. CAPACITIVE LOAD  
(DRIVING I/O  $V_L$ ,  $V_{CC} = +3.3V$ ,  $V_L = +1.8V$ )

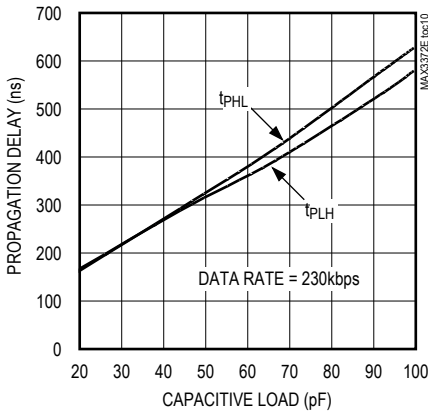

PROPAGATION DELAY vs. CAPACITIVE LOAD  
(DRIVING I/O  $V_L$ ,  $V_{CC} = +3.3V$ ,  $V_L = +1.8V$ )

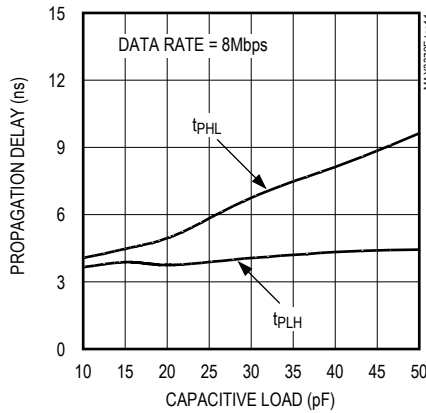

PROPAGATION DELAY vs. CAPACITIVE LOAD  
(DRIVING I/O  $V_L$ ,  $V_{CC} = +3.3V$ ,  $V_L = +1.8V$ )

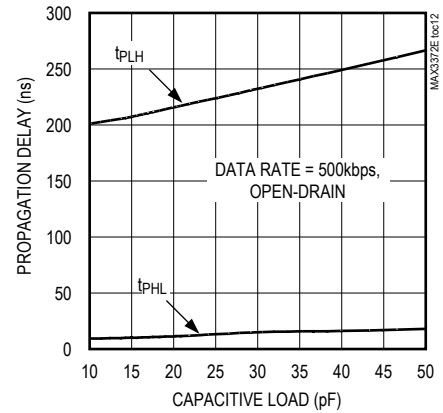

RISE/FALL TIME vs. CAPACITIVE LOAD  
(DRIVING I/O  $V_L$ ,  $V_{CC} = +2.5V$ ,  $V_L = +1.8V$ )

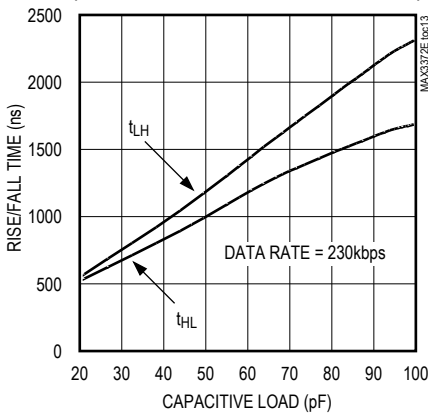

RISE/FALL TIME vs. CAPACITIVE LOAD  
(DRIVING I/O  $V_L$ ,  $V_{CC} = +2.5V$ ,  $V_L = +1.8V$ )

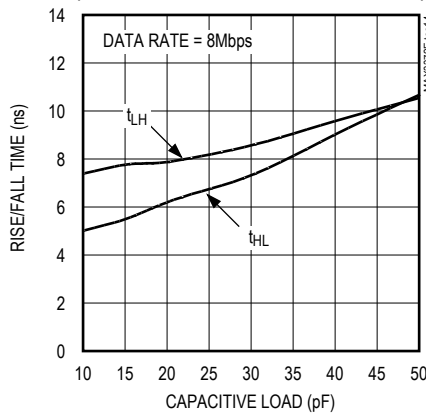

RISE/FALL TIME vs. CAPACITIVE LOAD  
(DRIVING I/O  $V_{CC}$ ,  $V_{CC} = +2.5V$ ,  $V_L = +1.8V$ )

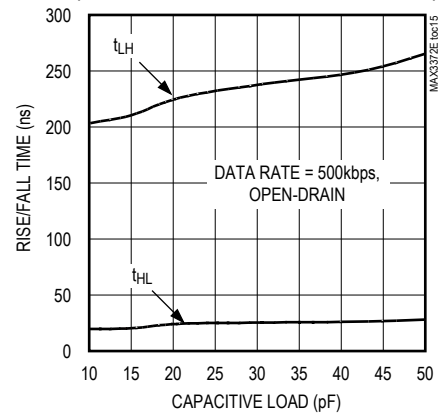

RISE/FALL TIME vs. CAPACITIVE LOAD  
(DRIVING I/O  $V_{CC}$ ,  $V_{CC} = +3.3V$ ,  $V_L = +1.8V$ )

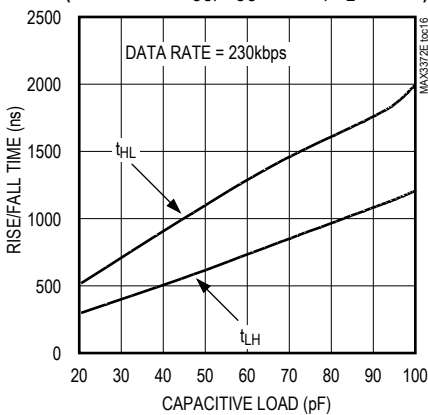

RISE/FALL TIME vs. CAPACITIVE LOAD  
(DRIVING I/O  $V_{CC}$ ,  $V_{CC} = +3.3V$ ,  $V_L = +1.8V$ )

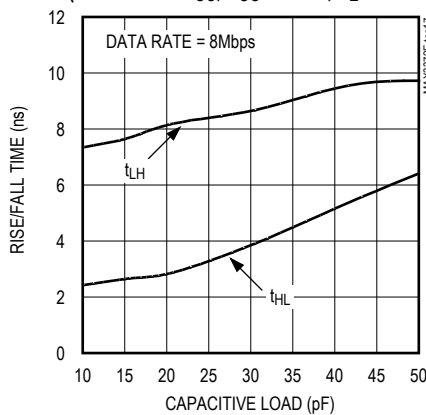

RISE/FALL TIME vs. CAPACITIVE LOAD  
(DRIVING I/O  $V_{CC}$ ,  $V_{CC} = +3.3V$ ,  $V_L = +1.8V$ )

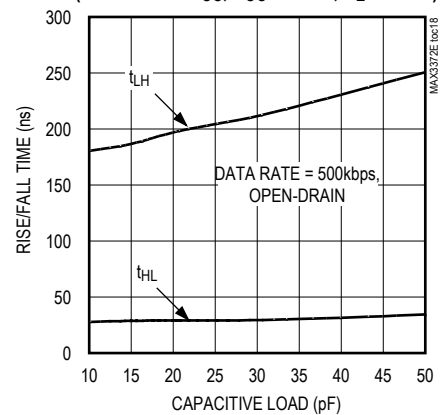

Typical Operating Characteristics (continued)

( $R_{LOAD} = 1M\Omega$ ,  $T_A = +25^\circ C$ , unless otherwise noted. All 230kbps TOCs apply to MAX3372E/MAX3377E only. All 8Mbps and 500kbps TOCs apply to MAX3373E–MAX3376E/MAX3378E/MAX3379E and MAX3390E–MAX3393E only.)

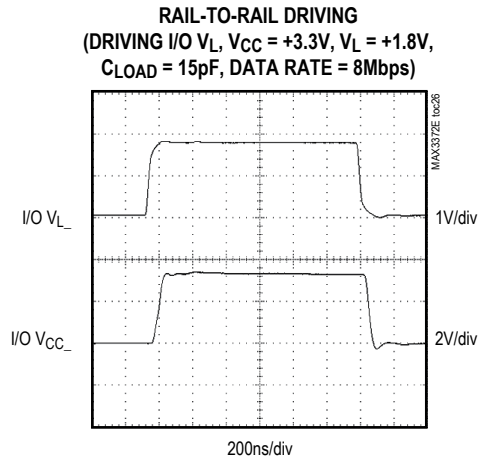
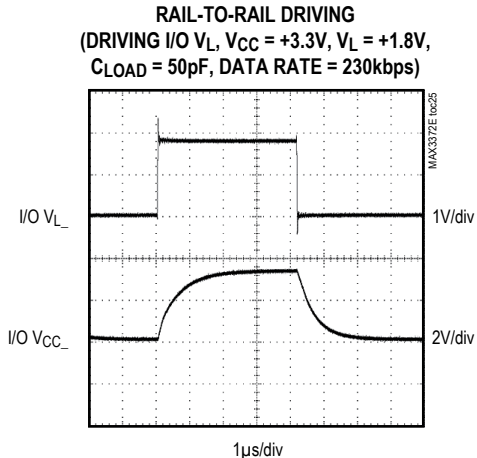
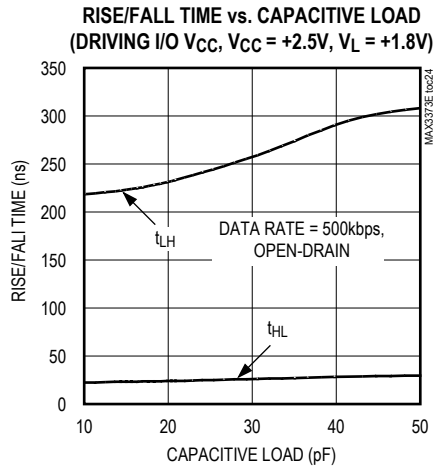
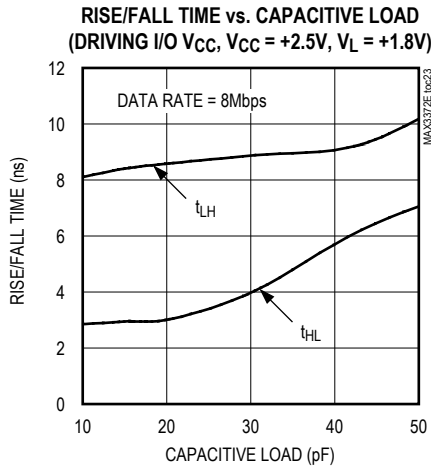
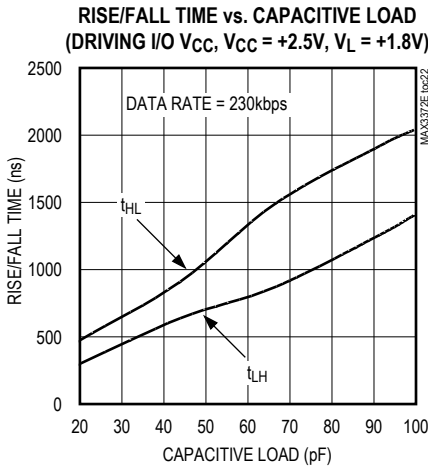
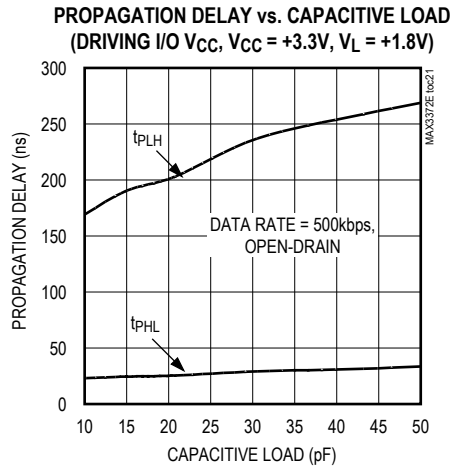
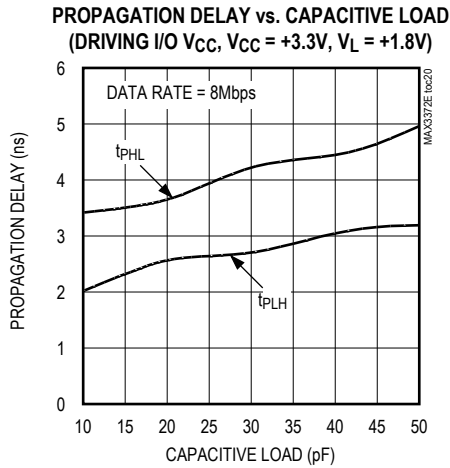
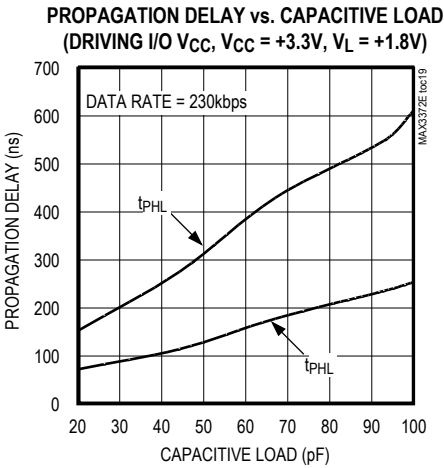

### Typical Operating Characteristics (continued)

( $R_{LOAD} = 1M\Omega$ ,  $T_A = +25^\circ C$ , unless otherwise noted. All 230kbps TOCs apply to MAX3372E/MAX3377E only. All 8Mbps and 500kbps TOCs apply to MAX3373E–MAX3376E/MAX3378E/MAX3379E and MAX3390E–MAX3393E only.)

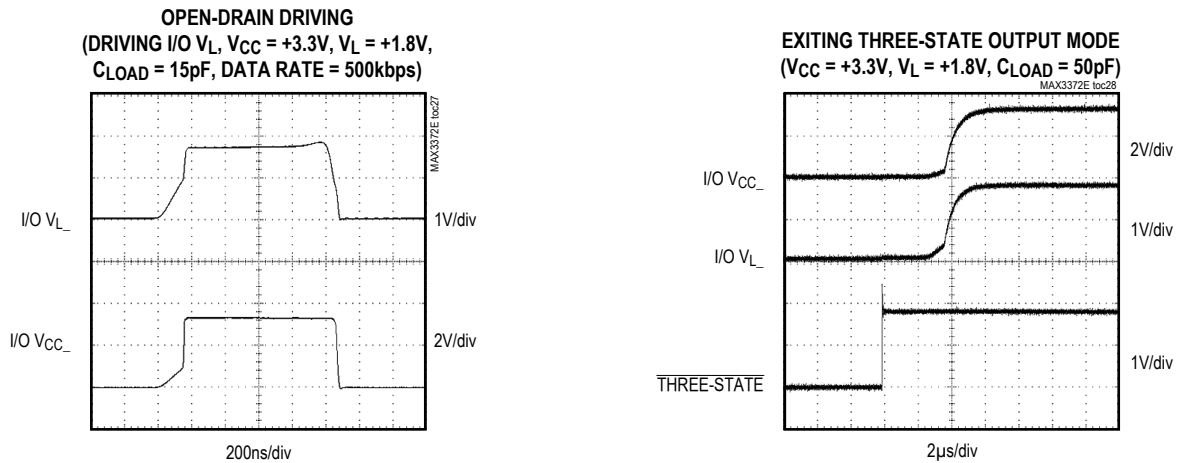

### Pin Description

PIN						NAME	FUNCTION
3 x 4 UCSP	14 TSSOP	SOT23-8	3 x 3 UCSP	8 TDFN-EP	14 TDFN-EP		
A1	2	5	C2	6	1	I/O $V_L1$	Input/Output 1. Referenced to $V_L$ . (Note 6)
A2	3	4	C3	8	2	I/O $V_L2$	Input/Output 2. Referenced to $V_L$ . (Note 6)
A3	4	—	—	—	5	I/O $V_L3$	Input/Output 3. Referenced to $V_L$ . (Note 6)
A4	5	—	—	—	6	I/O $V_L4$	Input/Output 4. Referenced to $V_L$ . (Note 6)
B1	14	7	A1	4	14	$V_{CC}$	$V_{CC}$ Input Voltage $+1.65V \leq V_{CC} \leq +5.5V$ .
B2	1	3	C1	7	10	$V_L$	Logic Input Voltage $+1.2V \leq V_L \leq (V_{CC} + 0.3V)$
B3	8	6	B1	5	3	$\overline{THREE-STATE}$	Three-State Output Mode Enable. Pull $\overline{THREE-STATE}$ low to place device in three-state output mode. I/O $V_{CC}$ and I/O $V_L$ are high impedance in three-state output mode. <b>Note:</b> Logic referenced to $V_L$ (for logic thresholds see the <i>Electrical Characteristics</i> table).
B4	7	2	B3	2	7	GND	Ground
C1	13	8	A2	3	13	I/O $V_{CC}1$	Input/Output 1. Referenced to $V_{CC}$ . (Note 6)
C2	12	1	A3	1	12	I/O $V_{CC}2$	Input/Output 2. Referenced to $V_{CC}$ . (Note 6)
C3	11	—	—	—	9	I/O $V_{CC}3$	Input/Output 3. Referenced to $V_{CC}$ . (Note 6)
C4	10	—	—	—	8	I/O $V_{CC}4$	Input/Output 4. Referenced to $V_{CC}$ . (Note 6)
—	6, 9	—	—	—	4, 11	N.C.	No Connection. Not internally connected.
—	—	—	B2	—	—	—	B2 bump is not populated for B9+2 9-UCSP packages
—	—	—	—	—	—	EP	Exposed Pad. Connect EP to ground.

**Note 6:** For unidirectional devices (MAX3374E/MAX3375E/MAX3376E/MAX3379E and MAX3390E–MAX3393E) see the *Pin Configurations* for input/output configurations.

**MAX3372E–MAX3379E/  
MAX3390E–MAX3393E**

**±15kV ESD-Protected, 1µA, 16Mbps, Dual/Quad  
Low-Voltage Level Translators in UCSP**

**Detailed Description**

The MAX3372E–MAX3379E and MAX3390E–MAX3393E ESD-protected level translators provide the level shifting necessary to allow data transfer in a multivoltage system. Externally applied voltages,  $V_{CC}$  and  $V_L$ , set the logic levels on either side of the device. A low-voltage logic signal present on the  $V_L$  side of the device appears as a high-voltage logic signal on the  $V_{CC}$  side of the device, and vice-versa. The MAX3374E/MAX3375E/MAX3376E/MAX3379E and MAX3390E–MAX3393E unidirectional level translators level shift data in one direction ( $V_L \rightarrow V_{CC}$  or  $V_{CC} \rightarrow V_L$ ) on any single data line. The MAX3372E/MAX3373E and MAX3377E/MAX3378E bidirectional level translators utilize a transmission-gatebased design (see Figure 2) to allow data translation in either direction ( $V_L \leftrightarrow V_{CC}$ ) on any single data line. The MAX3372E–MAX3379E and MAX3390E–MAX3393E accept  $V_L$  from

+1.2V to +5.5V and  $V_{CC}$  from +1.65V to +5.5V, making them ideal for data transfer between low-voltage ASICs/PLDs and higher voltage systems.

All devices in the MAX3372E–MAX3379E, MAX3390E–MAX3393E family feature a three-state output mode that reduces supply current to less than 1µA, thermal shortcircuit protection, and ±15kV ESD protection on the  $V_{CC}$  side for greater protection in applications that route signals externally. The MAX3372E/MAX3377E operate at a guaranteed data rate of 230kbps. Slew-rate limiting reduces EMI emissions in all 230kbps devices. The MAX3373E–MAX3376E/MAX3378E/MAX3379E and MAX3390E–MAX3393E operate at a guaranteed data rate of 8Mbps over the entire specified operating voltage range. Within specific voltage domains, higher data rates are possible. (See the *Timing Characteristics* table.)

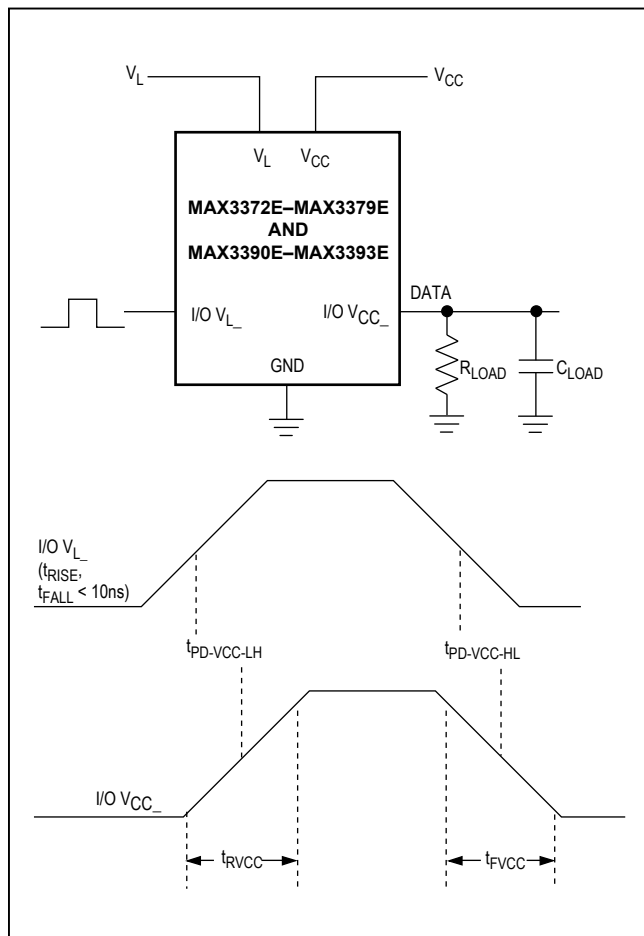

Figure 1a. Rail-to-Rail Driving I/O  $V_L$

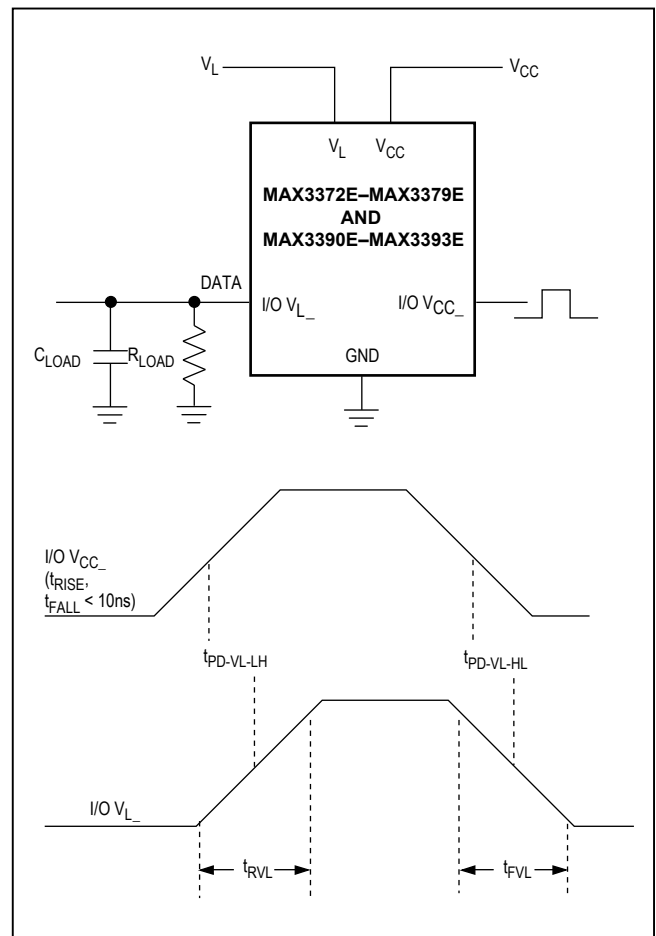

Figure 1b. Rail-to-Rail Driving I/O  $V_{CC}$

# MAX3372E–MAX3379E/ MAX3390E–MAX3393E

±15kV ESD-Protected, 1µA, 16Mbps, Dual/Quad  
Low-Voltage Level Translators in UCSP

## Level Translation

For proper operation ensure that  $+1.65V \leq V_{CC} \leq +5.5V$ ,  $+1.2V \leq V_L \leq +5.5V$ , and  $V_L \leq (V_{CC} + 0.3V)$ . During power-up sequencing,  $V_L \geq (V_{CC} + 0.3V)$  will not damage the device. During power-supply sequencing, when  $V_{CC}$  is floating and  $V_L$  is powering up, a current may be sourced, yet the device will not latch up. The speed-up circuitry limits the maximum data rate for devices in the MAX3372E–MAX3379E, MAX3390E–MAX3393E family to 16Mbps. The maximum data rate also depends heavily on the load capacitance (see the *Typical Operating Characteristics*), output impedance of the driver, and the operational voltage range (see the *Timing Characteristics* table).

## Speed-Up Circuitry

The MAX3373E–MAX3376E/MAX3378E/MAX3379E and MAX3390E–MAX3393E feature a one-shot generator that decreases the rise time of the output. When triggered, MOSFETs PU1 and PU2 turn on for a short time

to pull up I/O  $V_L$  and I/O  $V_{CC}$  to their respective supplies (see Figure 2b). This greatly reduces the rise time and propagation delay for the low-to-high transition. The scope photo of Rail-to-Rail Driving for 8Mbps Operation in the *Typical Operating Characteristics* shows the speed-up circuitry in operation.

## Rise-Time Accelerators

The MAX3373E–MAX3376E/MAX3378E/MAX3379E and the MAX3390E–MAX3393E have internal rise-time accelerators allowing operation up to 16Mbps. The rise-time accelerators are present on both sides of the device and act to speed up the rise time of the input and output of the device, regardless of the direction of the data. The triggering mechanism for these accelerators is both level and edge sensitive. To prevent false triggering of the rise-time accelerators, signal fall times of less than 20ns/V are recommended for both the inputs and outputs of the device. Under less noisy conditions, longer signal fall times may be acceptable.

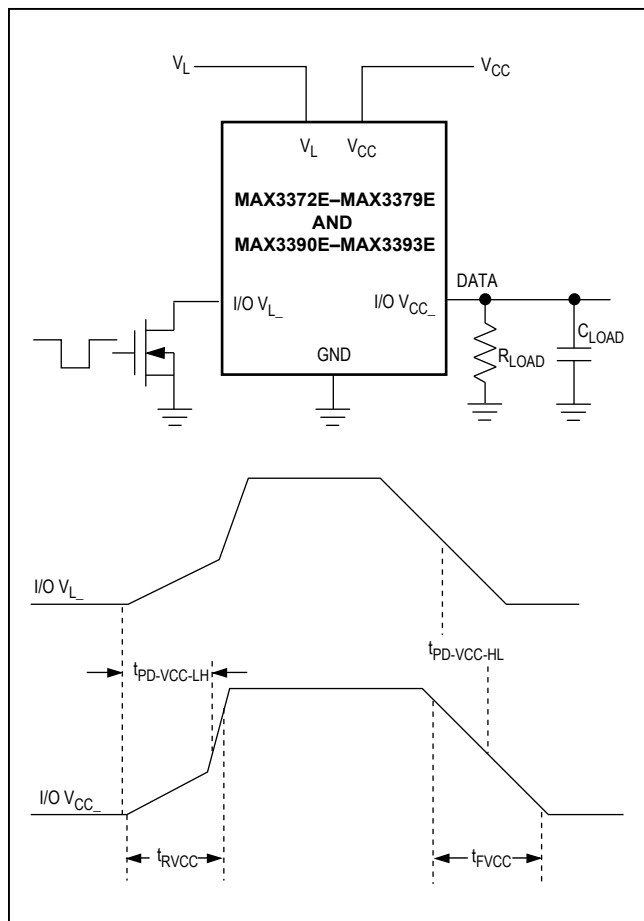

Figure 1c. Open-Drain Driving I/O  $V_{CC}$

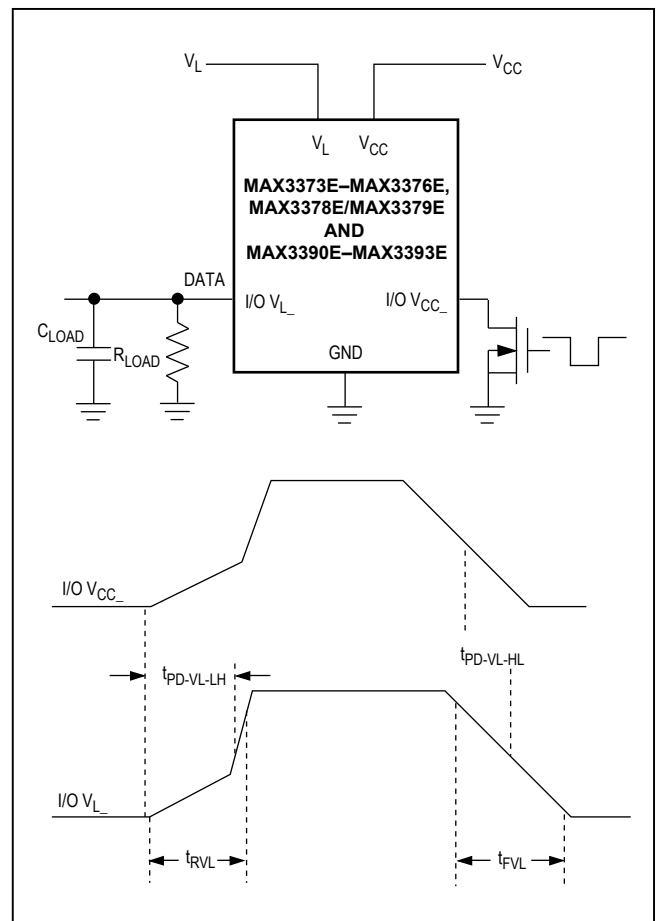

Figure 1d. Open-Drain Driving I/O  $V_L$

### Three-State Output Mode

Pull  $\overline{\text{THREE-STATE}}$  low to place the MAX3372E–MAX3379E and MAX3390E–MAX3393E in three-state output mode. Connect  $\overline{\text{THREE-STATE}}$  to  $V_L$  (logic-high) for normal operation. Activating the three-state output mode disconnects the internal 10kΩ pullup resistors on the I/O  $V_{CC}$  and I/O  $V_L$  lines. This forces the I/O lines to a high-impedance state, and decreases the supply current to less than 1µA. The high-impedance I/O lines in three-state output mode allow for use in a multidrop network. When in three-state output mode, do not allow the voltage

at I/O  $V_L$  to exceed  $(V_L + 0.3V)$ , or the voltage at I/O  $V_{CC}$  to exceed  $(V_{CC} + 0.3V)$ .

### Thermal Short-Circuit Protection

Thermal overload detection protects the MAX3372E–MAX3379E and MAX3390E–MAX3393E from short-circuit fault conditions. In the event of a short-circuit fault, when the junction temperature ( $T_J$ ) reaches +152°C, a thermal sensor signals the three-state output mode logic to force the device into three-state output mode. When  $T_J$  has cooled to +142°C, normal operation resumes.

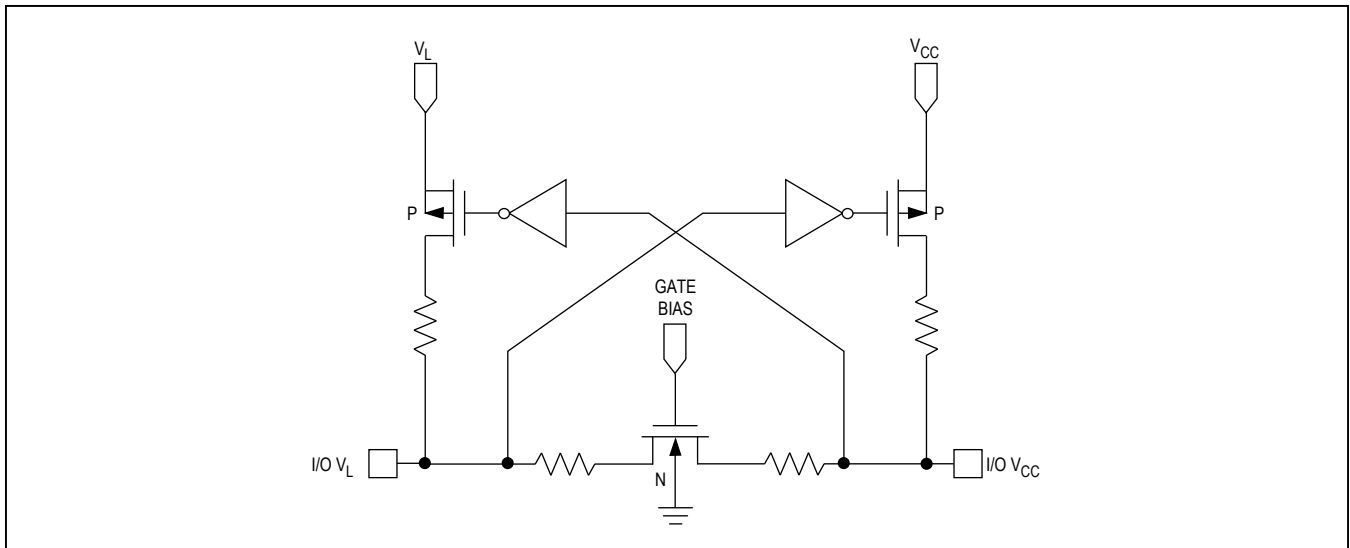

Figure 2a. Functional Diagram, MAX3372E/MAX3377E (1 I/O line)

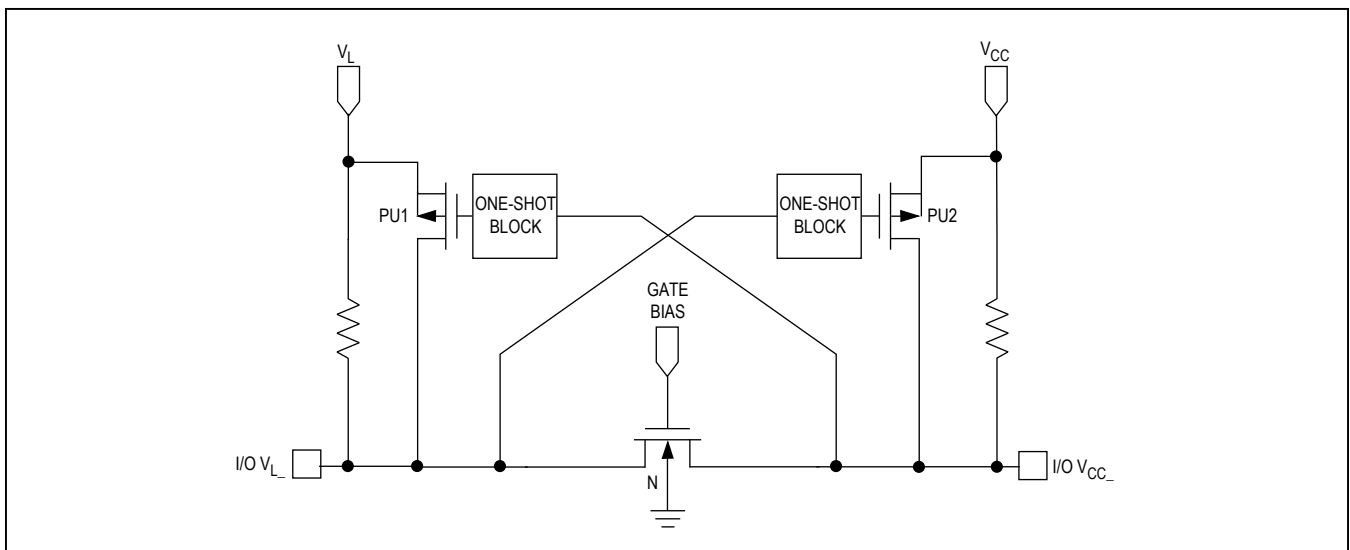

Figure 2b. Functional Diagram, MAX3373E/MAX3378E (1 I/O line)

### ±15kV ESD Protection

As with all Maxim devices, ESD-protection structures are incorporated on all pins to protect against electrostatic discharges encountered during handling and assembly. The I/O  $V_{CC}$  lines have extra protection against static electricity. Maxim’s engineers have developed state-of-the-art structures to protect these pins against ESD of ±15kV without damage. The ESD structures withstand high ESD in all states: normal operation, three-state output mode, and powered down. After an ESD event, Maxim’s E versions keep working without latchup, whereas competing products can latch and must be powered down to remove latchup.

ESD protection can be tested in various ways. The I/O  $V_{CC}$  lines of this product family are characterized for protection to the following limits:

- 1) ±15kV using the Human Body Model
- 2) ±8kV using the Contact Discharge method specified in IEC 1000-4-2
- 3) ±10kV using IEC 1000-4-2’s Air-Gap Discharge method

### ESD Test Conditions

ESD performance depends on a variety of conditions. Contact Maxim for a reliability report that documents test setup, test methodology, and test results.

### Human Body Model

Figure 3a shows the Human Body Model and Figure 3b shows the current waveform it generates when discharged into a low impedance. This model consists of a 100pF capacitor charged to the ESD voltage of interest, which is then discharged into the test device through a 1.5kΩ resistor.

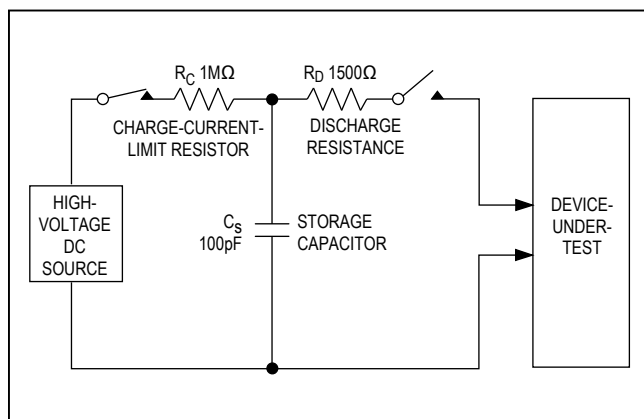

Figure 3a. Human Body ESD Test Model

### IEC 1000-4-2

The IEC 1000-4-2 standard covers ESD testing and performance of finished equipment; it does not specifically refer to integrated circuits. The MAX3372E–MAX3379E and MAX3390E–MAX3393E help to design equipment that meets Level 3 of IEC 1000-4-2, without the need for additional ESD-protection components.

The major difference between tests done using the Human Body Model and IEC 1000-4-2 is higher peak current in IEC 1000-4-2, because series resistance is lower in the IEC 1000-4-2 model. Hence, the ESD with-stand voltage measured to IEC 1000-4-2 is generally lower than that measured using the Human Body Model. Figure 4a shows the IEC 1000-4-2 model, and Figure 4b shows the current waveform for the ±8kV, IEC 1000-4-2, Level 4, ESD contact-discharge test.

The air-gap test involves approaching the device with a charged probe. The contact-discharge method connects the probe to the device before the probe is energized.

### Machine Model

The Machine Model for ESD tests all pins using a 200pF storage capacitor and zero discharge resistance. Its objective is to emulate the stress caused by contact that occurs with handling and assembly during manufacturing. Of course, all pins require this protection during manufacturing, not just inputs and outputs. Therefore, after PCB assembly, the Machine Model is less relevant to I/O ports.

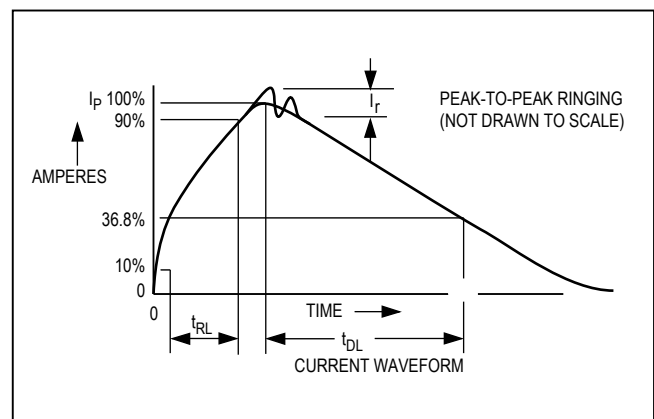

Figure 3b. Human Body Current Waveform

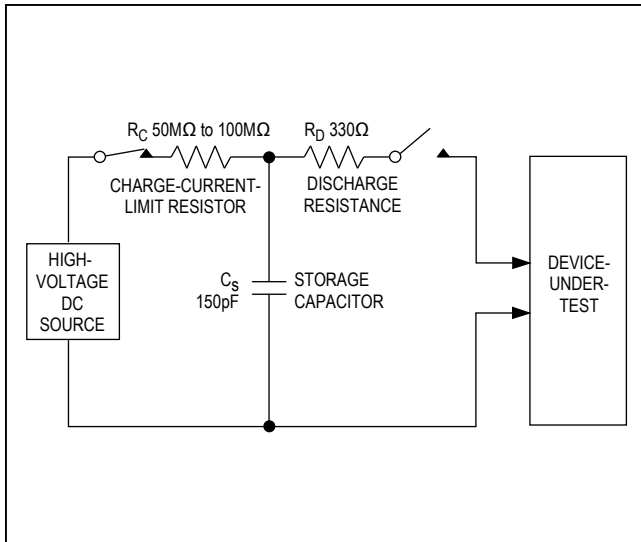

Figure 4a. IEC 1000-4-2 ESD Test Model

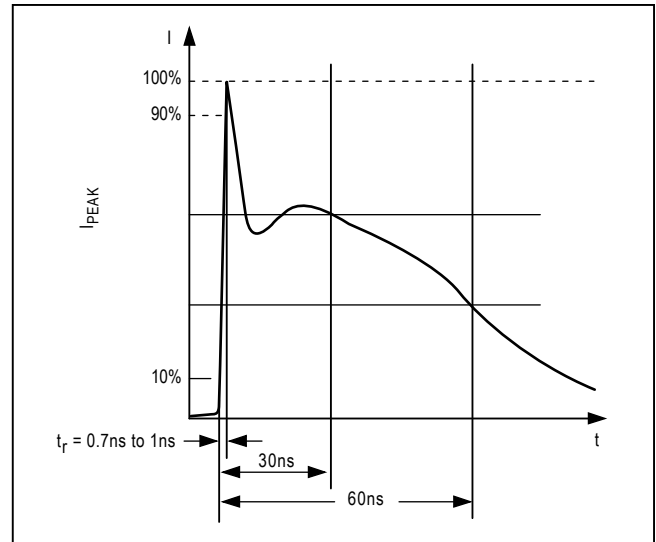

Figure 4b. IEC 1000-4-2 ESD Generator Current Waveform

## Applications Information

### Power-Supply Decoupling

To reduce ripple and the chance of transmitting incorrect data, bypass  $V_L$  and  $V_{CC}$  to ground with a 0.1μF capacitor. See the *Typical Operating Circuit*. To ensure full ±15kV ESD protection, bypass  $V_{CC}$  to ground with a 1μF capacitor. Place all capacitors as close to the power-supply inputs as possible.

### I<sup>2</sup>C Level Translation

The MAX3373E–MAX3376E, MAX3378E/MAX3379E and MAX3390E–MAX3393E level-shift the data present on the I/O lines between +1.2V and +5.5V, making them

ideal for level translation between a low-voltage ASIC and an I<sup>2</sup>C device. A typical application involves interfacing a low-voltage microprocessor to a 3V or 5V D/A converter, such as the MAX517.

### Push-Pull vs. Open-Drive Driving

All devices in the MAX3372E–MAX3379E and MAX3390E–MAX3393E family may be driven in a pushpull configuration. The MAX3373E–MAX3376E/MAX3378E/MAX3379E and MAX3390E–MAX3393E include internal 10kΩ resistors that pull up I/O  $V_L$  and I/O  $V_{CC}$  to their respective power supplies, allowing operation of the I/O lines with open-drain devices. See the *Timing Characteristics* table for maximum data rates when using open-drain drivers.

## Typical Operating Circuit

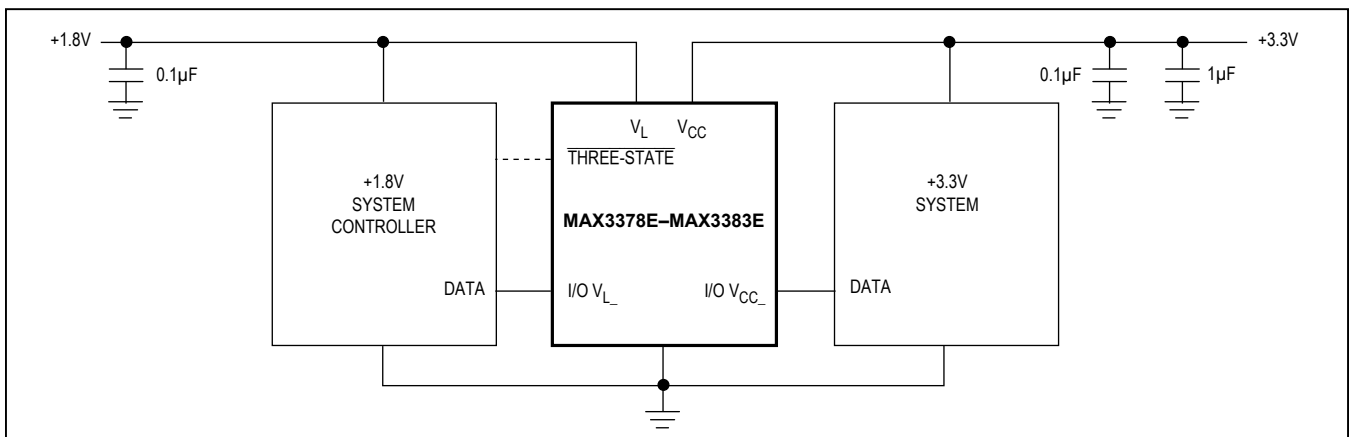

### Applications Circuits

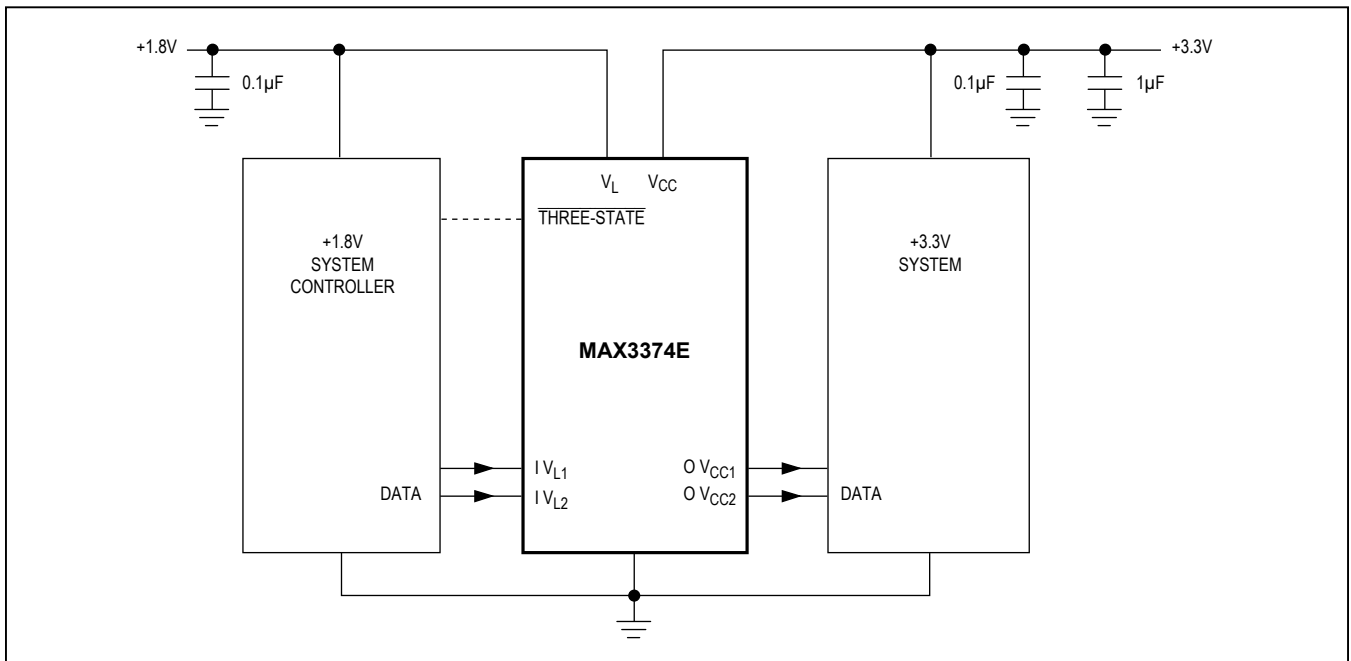
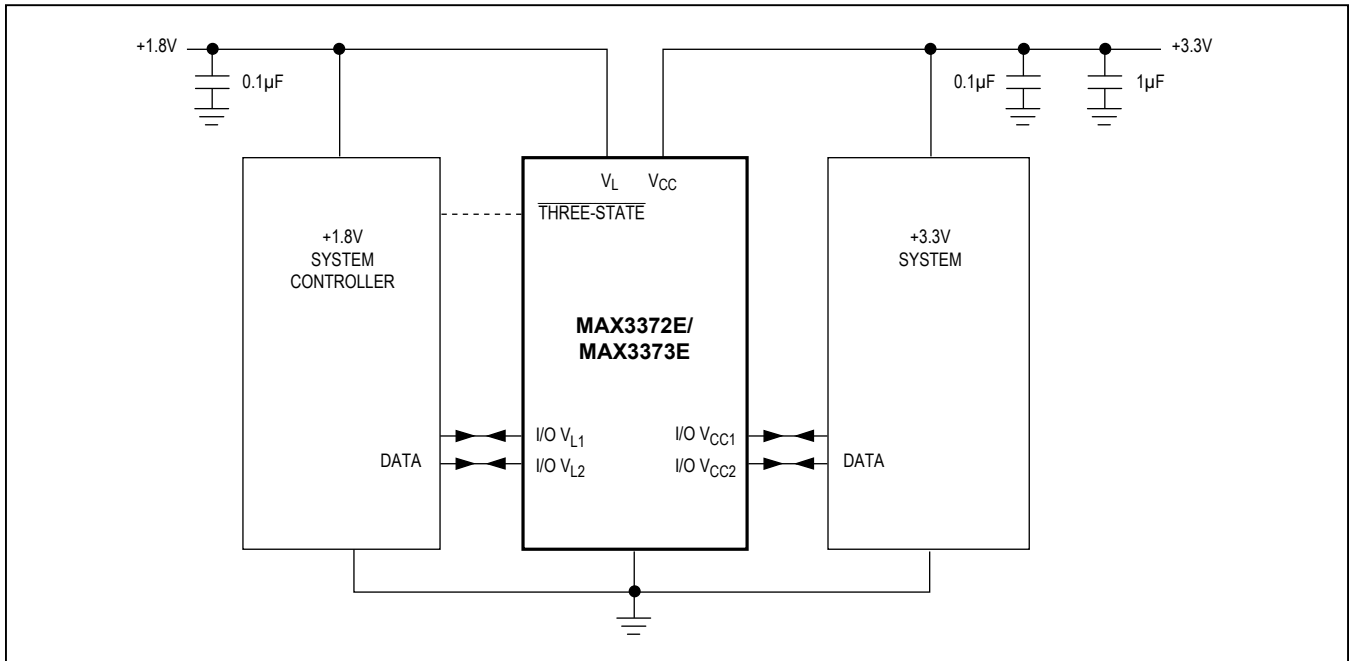

Applications Circuits (continued)

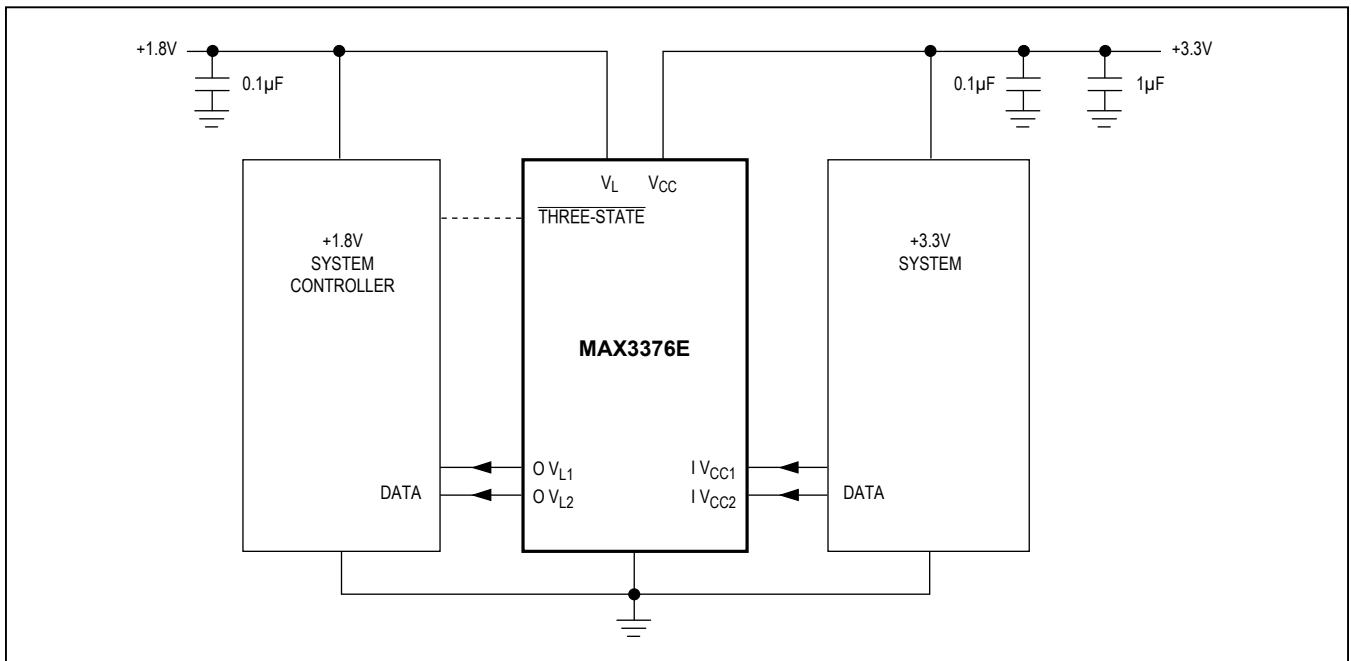
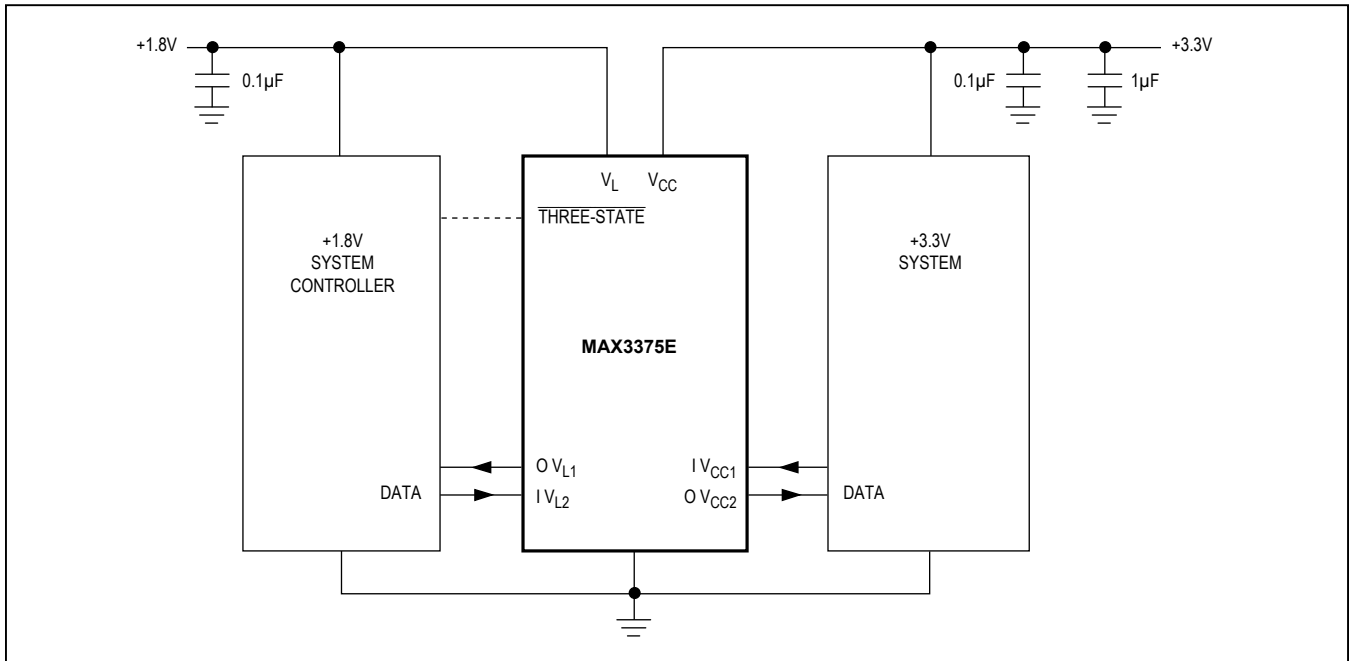

MAX3372E–MAX3379E/  
MAX3390E–MAX3393E

±15kV ESD-Protected, 1µA, 16Mbps, Dual/Quad  
Low-Voltage Level Translators in UCSP

### Applications Circuits (continued)

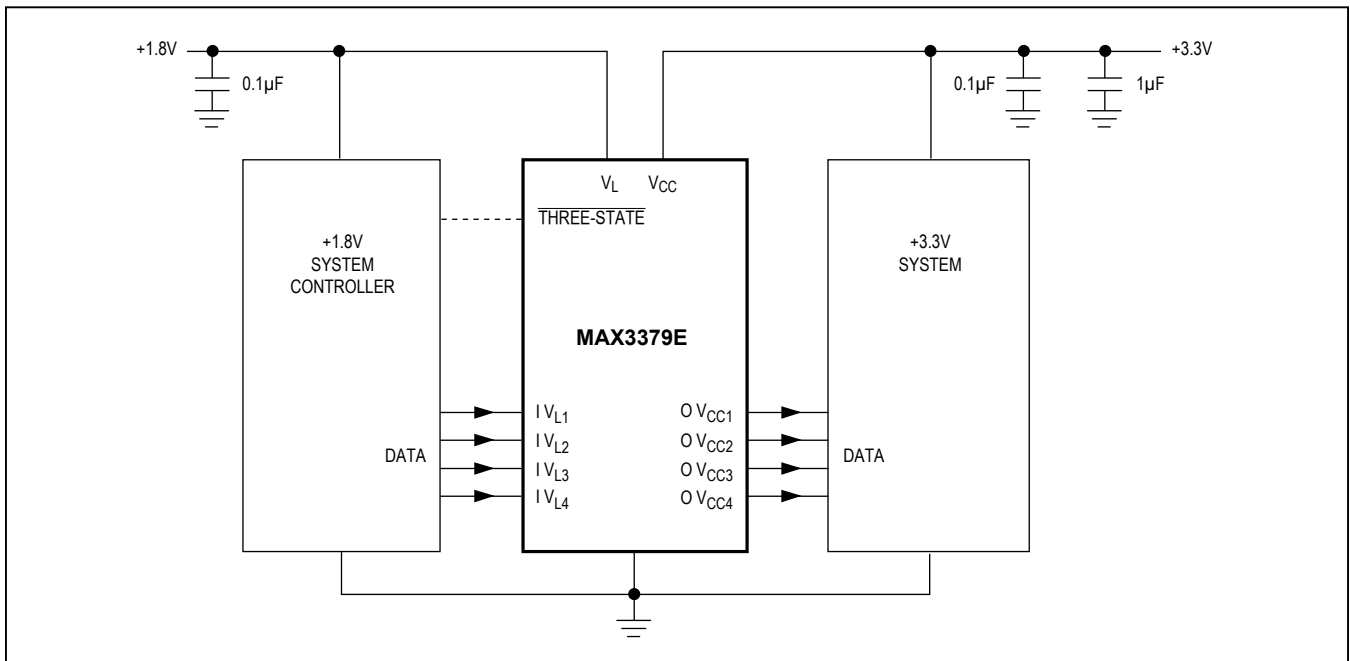
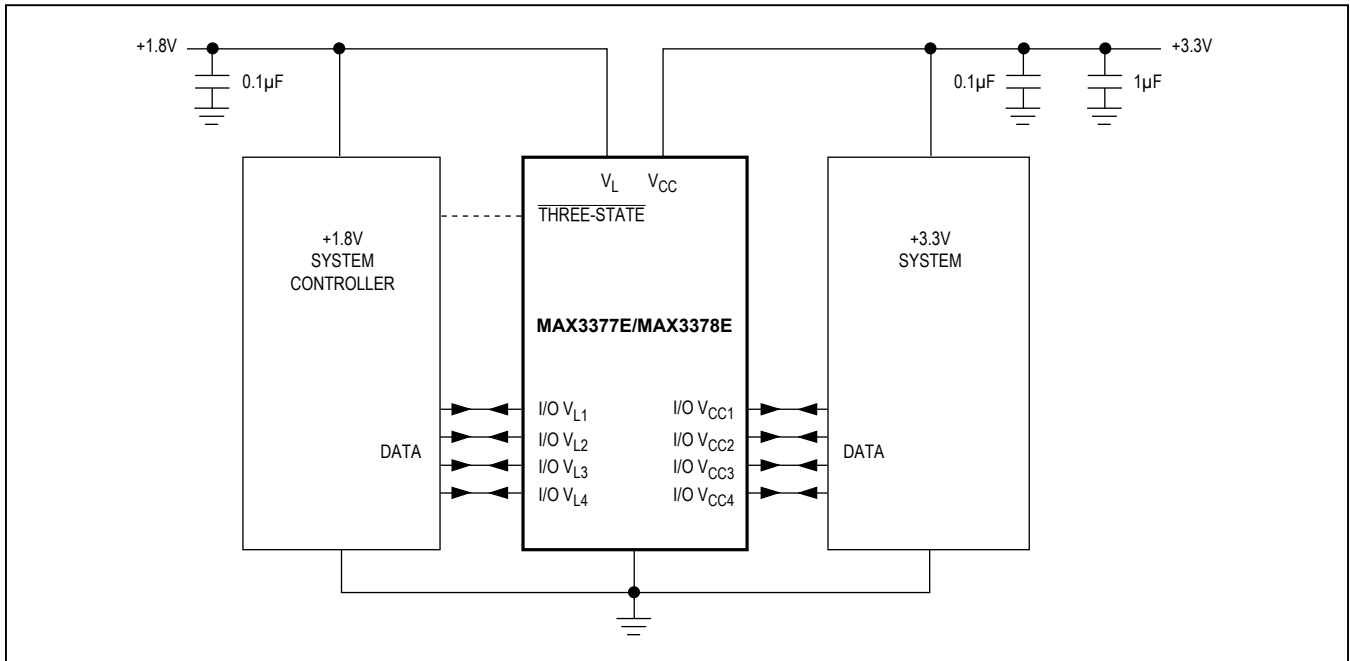

MAX3372E–MAX3379E/  
MAX3390E–MAX3393E

±15kV ESD-Protected, 1µA, 16Mbps, Dual/Quad  
Low-Voltage Level Translators in UCSP

### Applications Circuits (continued)

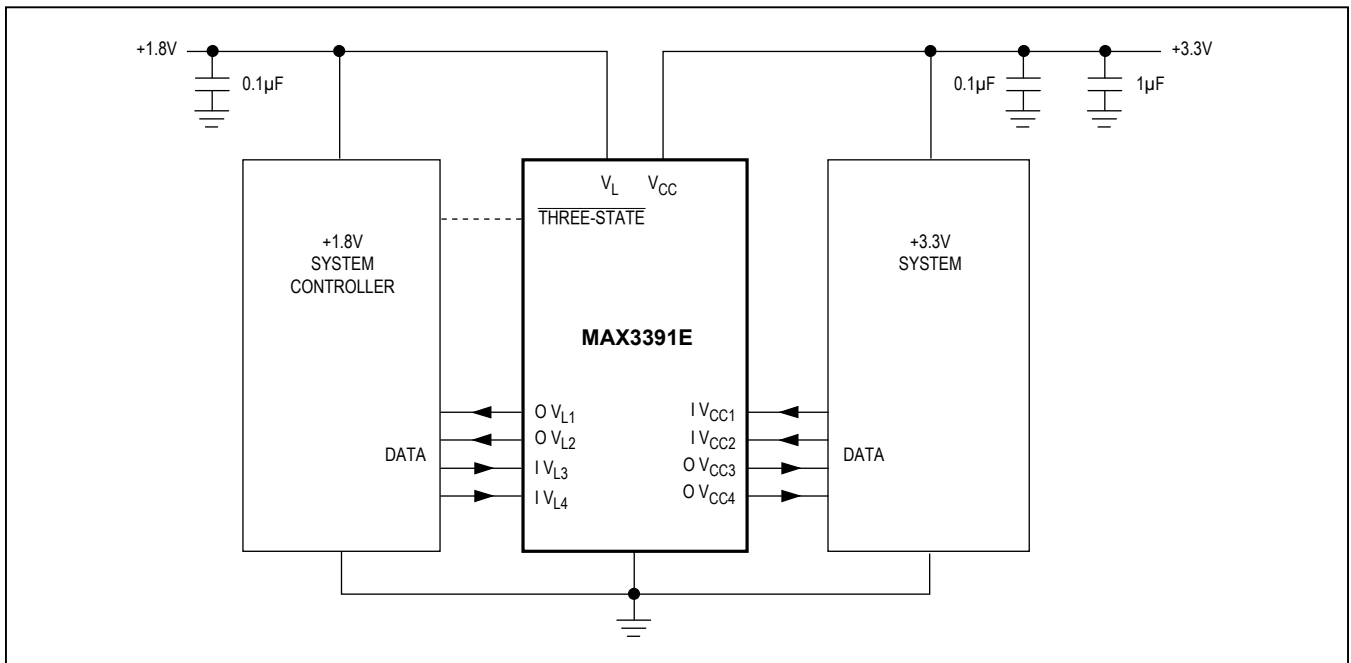
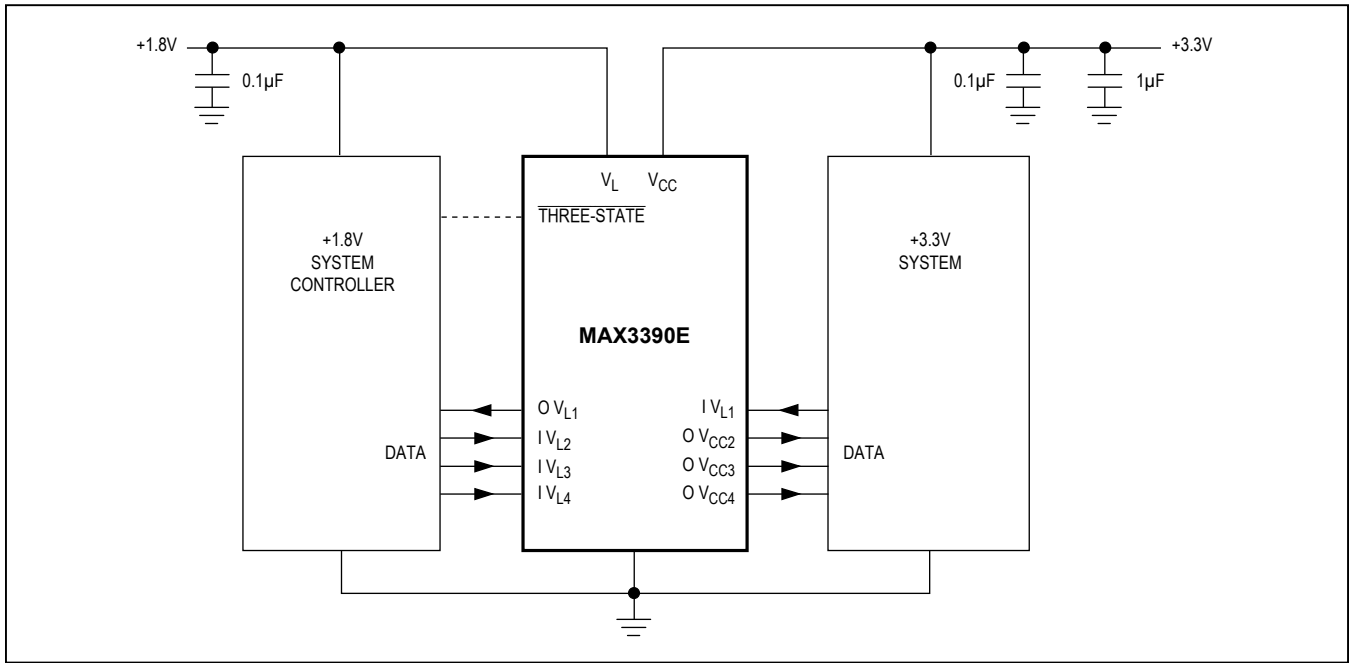

MAX3372E–MAX3379E/  
MAX3390E–MAX3393E

±15kV ESD-Protected, 1µA, 16Mbps, Dual/Quad  
Low-Voltage Level Translators in UCSP

### Applications Circuits (continued)

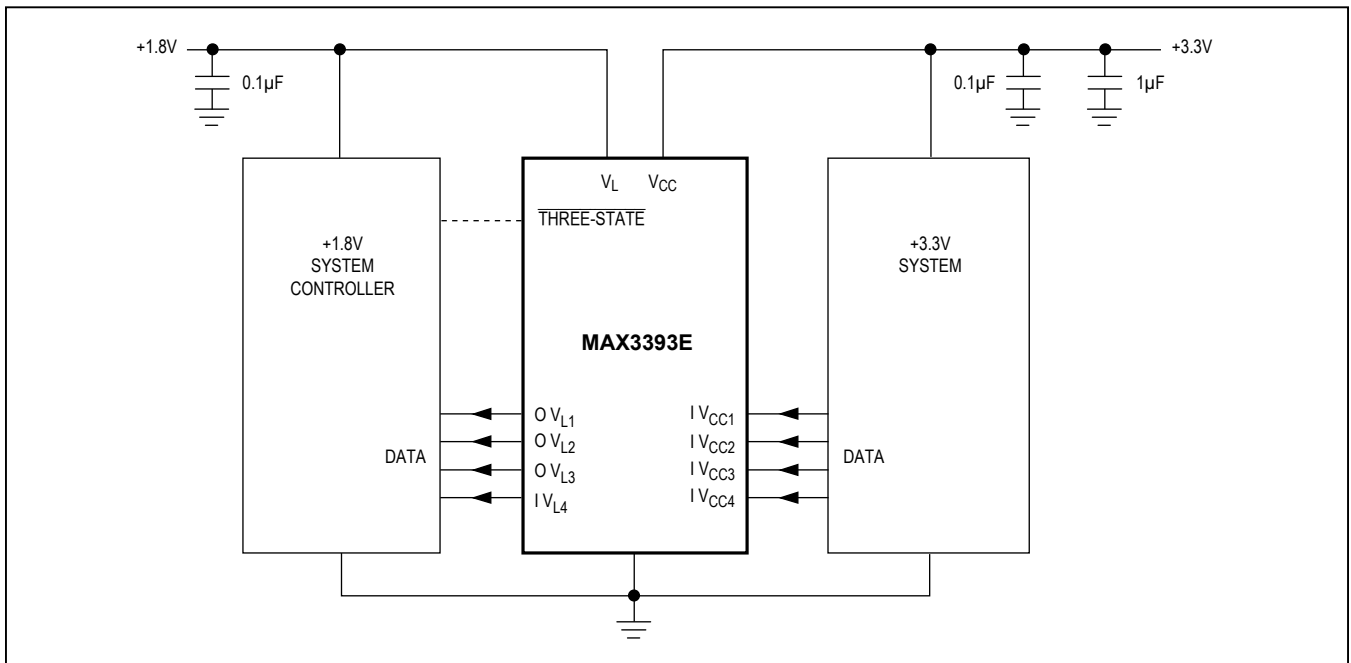
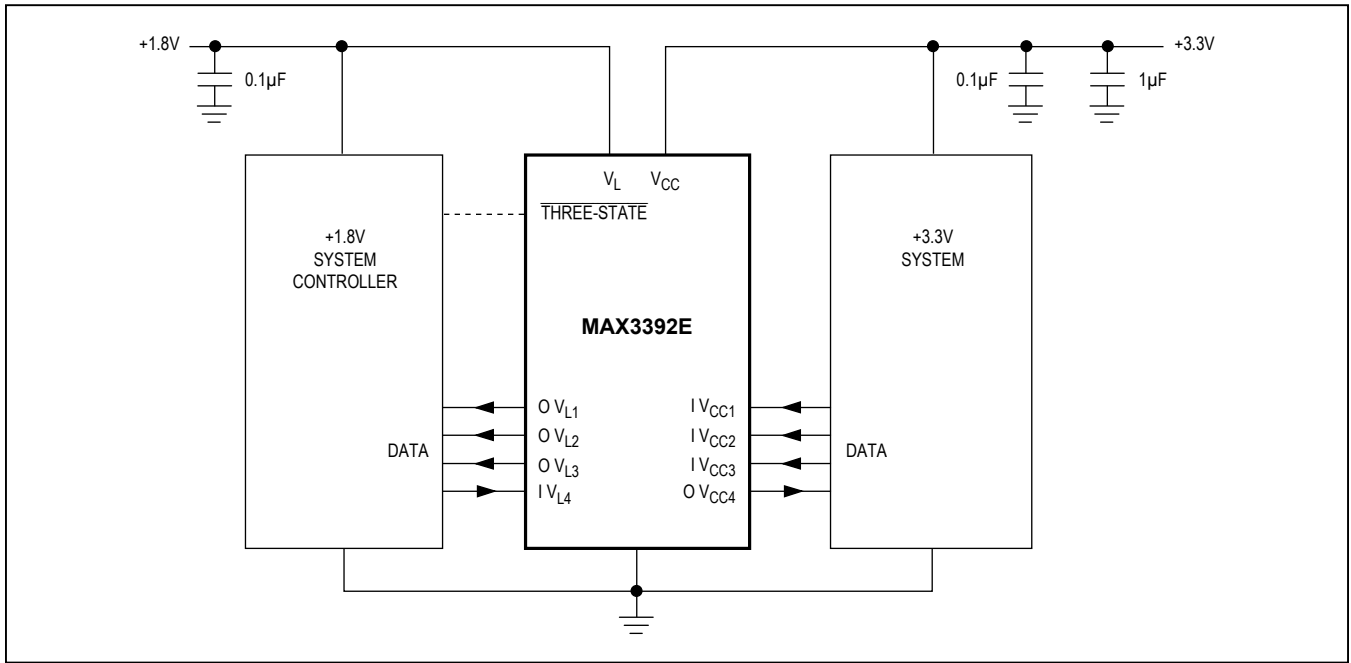

MAX3372E–MAX3379E/  
MAX3390E–MAX3393E

±15kV ESD-Protected, 1µA, 16Mbps, Dual/Quad  
Low-Voltage Level Translators in UCSP

## Ordering Information

PART	TEMP RANGE	PIN-PACKAGE
<b>MAX3372EEKA+T</b>	-40°C to +85°C	8 SOT23
MAX3372EEBL+T	-40°C to +85°C	9 UCSP (1.5mm x 1.5mm)
<b>MAX3373EEKA+T</b>	-40°C to +85°C	8 SOT23
MAX3373EEBL+T	-40°C to +85°C	9 UCSP (1.5mm x 1.5mm)
<b>MAX3374EEKA+T</b>	-40°C to +85°C	8 SOT23
<b>MAX3375EEKA+T</b>	-40°C to +85°C	8 SOT23
MAX3375EEBL+T	-40°C to +85°C	9 UCSP (1.5mm x 1.5mm)
<b>MAX3376EEKA+T</b>	-40°C to +85°C	8 SOT23
<b>MAX3377EEUD+</b>	-40°C to +85°C	14 TSSOP
MAX3377EETD+T	-40°C to +85°C	14 TDFN-EP** (3mm x 3mm)
<b>MAX3378EEUD+</b>	-40°C to +85°C	14 TSSOP
MAX3378EEBC+T	-40°C to +85°C	12 UCSP (1.5mm x 2.0mm)
MAX3378EETD+T	-40°C to +85°C	14 TDFN-EP** (3mm x 3mm)

PART	TEMP RANGE	PIN-PACKAGE
<b>MAX3379EEUD+</b>	-40°C to +85°C	14 TSSOP
MAX3379EETD+T	-40°C to +85°C	14 TDFN-EP** (3mm x 3mm)
<b>MAX3390EEUD+</b>	-40°C to +85°C	14 TSSOP
<b>MAX3391EEUD+</b>	-40°C to +85°C	14 TSSOP
MAX3391EEBC+T	-40°C to +85°C	12 UCSP (1.5mm x 2.0mm)
MAX3391EETD+T	-40°C to +85°C	14 TDFN-EP** (3mm x 3mm)
<b>MAX3392EEUD+</b>	-40°C to +85°C	14 TSSOP
<b>MAX3393EEUD+</b>	-40°C to +85°C	14 TSSOP
MAX3393EEBC+T	-40°C to +85°C	12 UCSP (1.5mm x 2.0mm)

+Denotes a lead-free package.

\*\*EP = Exposed pad.

T = Tape and reel.

MAX3372E–MAX3379E/  
MAX3390E–MAX3393E

±15kV ESD-Protected, 1µA, 16Mbps, Dual/Quad  
Low-Voltage Level Translators in UCSP

## Selector Guide

PART	LEVEL TRANSLATION	Tx/Rx†	DATA RATE	TOP MARK
MAX3372EEKA+T	✓ Bi	2/2	230kbps	AAKO
MAX3372EEBL+T	✓ Bi	2/2		AAR
MAX3372EETA+T	✓ Bi	2/2		AQG
MAX3373EEKA+T	✓ Bi	2/2	8Mbps*	AAKS
MAX3373EEBL+T	✓ Bi	2/2		AAZ
MAX3373EETA+T	✓ Bi	2/2		AQH
MAX3374EEKA+T	Uni	2/0		AALH
MAX3374EEBL+T	Uni	2/0		ABA
MAX3374EETA+T	Uni	2/0		AQI
MAX3375EEKA+T	Uni	1/1		AALI
MAX3375EEBL+T	Uni	1/1		ABB
MAX3375EETA+T	Uni	1/1		AQJ
MAX3376EEKA+T	Uni	0/2		AALG
MAX3376EEBL+T	Uni	0/2		AAV
MAX3376EETA+T	Uni	0/2		AQK
MAX3377EEUD+	✓ Bi	4/4	230kbps	—
MAX3377EEBC+T	✓ Bi	4/4		AAX
MAX3377EETD+T	✓ Bi	4/4		AAG

PART	LEVEL TRANSLATION	Tx/Rx†	DATA RATE	TOP MARK
MAX3378EEUD+	✓ Bi	4/4	8Mbps*	—
MAX3378EEBC+T	✓ Bi	4/4		AAZ
MAX3378EETD+T	✓ Bi	4/4		AAH
MAX3379EEUD+	Uni	4/0		—
MAX3379EEBC+T	Uni	4/0		AAZ
MAX3379EETD+T	Uni	4/0		AAI
MAX3390EEUD+	Uni	3/1		—
MAX3390EEBC+T	Uni	3/1		ABA
MAX3390EETD+T	Uni	3/1		AAJ
MAX3391EEUD+	Uni	2/2		—
MAX3391EEBC+T	Uni	2/2		ABB
MAX3391EETD+T	Uni	2/2		AAK
MAX3392EEUD+	Uni	1/3		—
MAX3392EEBC+T	Uni	1/3		ABC
MAX3392EETD+T	Uni	1/3		AAL
MAX3393EEUD+	Uni	0/4		—
MAX3393EEBC+T	Uni	0/4		ABD
MAX3393EETD+T	Uni	0/4		AAM

†Tx =  $V_L \rightarrow V_{CC}$ , Rx =  $V_{CC} \rightarrow V_L$

\*Higher data rates are possible (see the Timing Characteristics table).

Pin Configurations (continued)

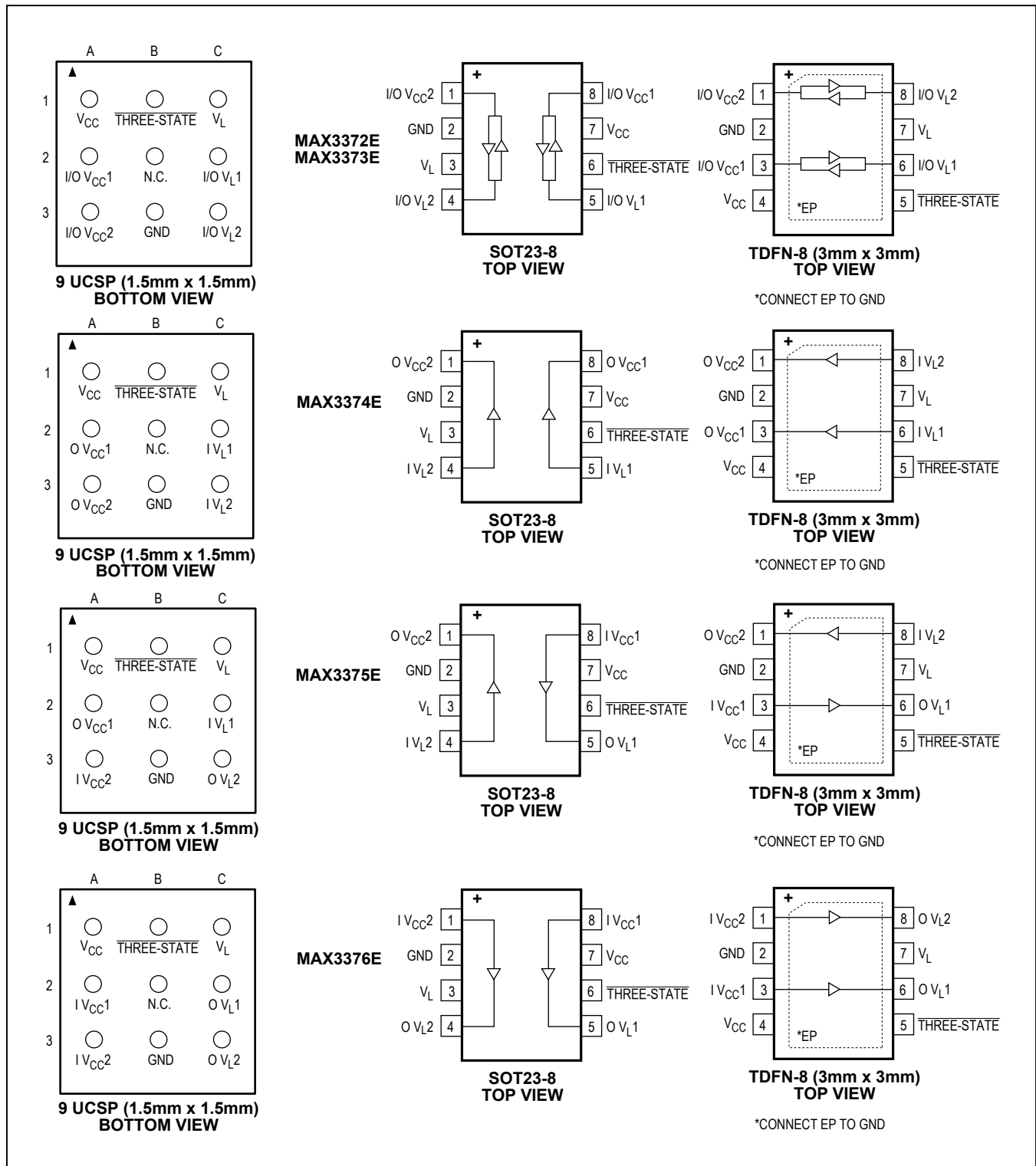

Pin Configurations (continued)

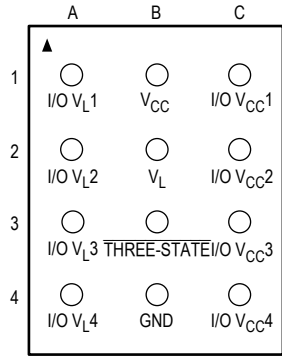

12 UCSP (1.5mm x 2.0mm)  
BOTTOM VIEW

MAX3377E  
MAX3378E

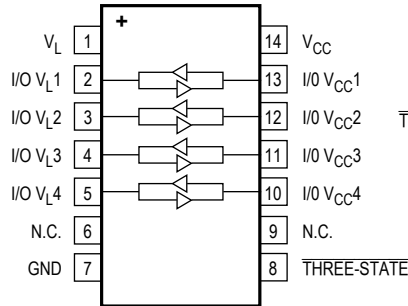

TSSOP-14  
TOP VIEW

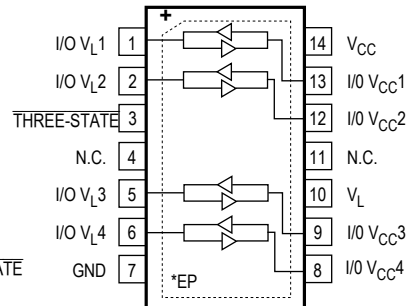

TDFN-14 (3mm x 3mm)  
TOP VIEW

\*CONNECT EP TO GND

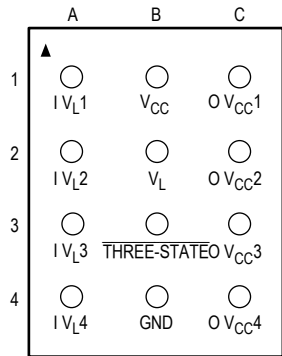

12 UCSP (1.5mm x 2.0mm)  
BOTTOM VIEW

MAX3379E

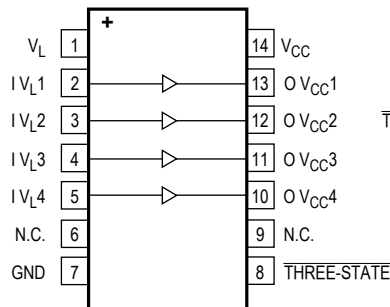

TSSOP-14  
TOP VIEW

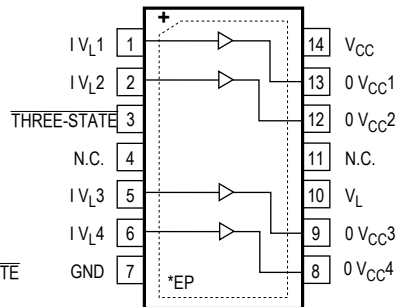

TDFN-14 (3mm x 3mm)  
TOP VIEW

\*CONNECT EP TO GND

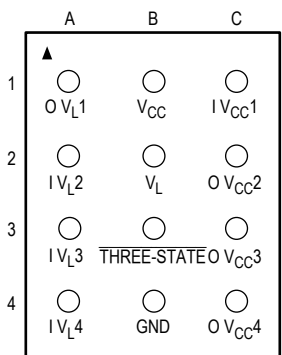

12 UCSP (1.5mm x 2.0mm)  
BOTTOM VIEW

MAX3390E

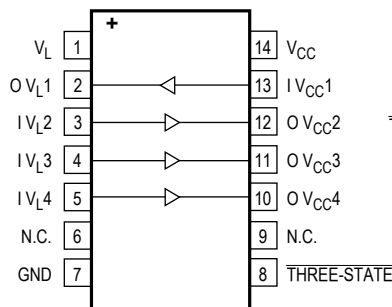

TSSOP-14  
TOP VIEW

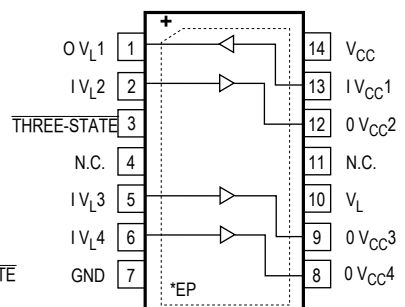

TDFN-14 (3mm x 3mm)  
TOP VIEW

\*CONNECT EP TO GND

Pin Configurations (continued)

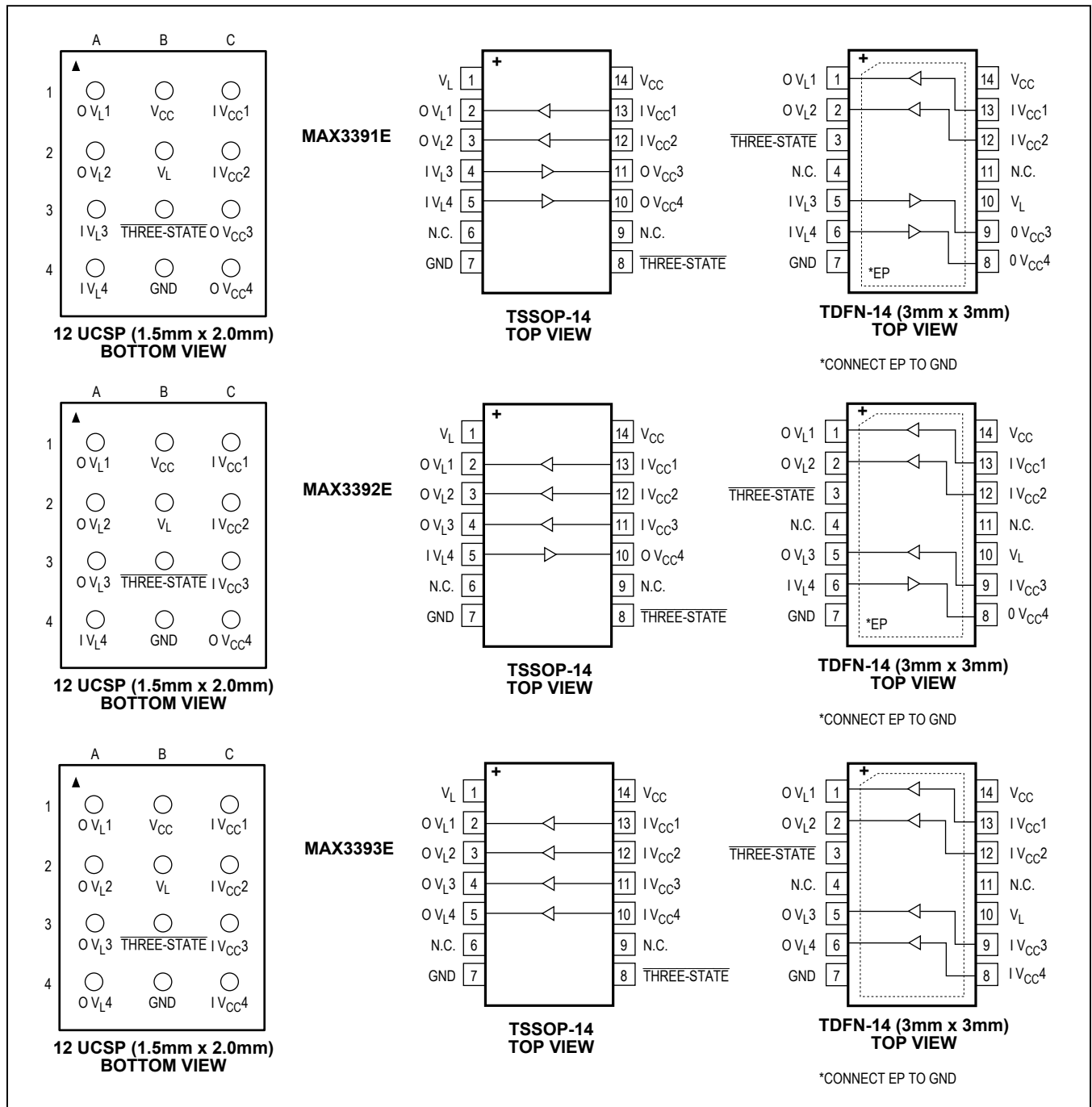

Chip Information

PROCESS: BiCMOS

MAX3372E–MAX3379E/  
MAX3390E–MAX3393E

±15kV ESD-Protected, 1µA, 16Mbps, Dual/Quad  
Low-Voltage Level Translators in UCSP

Package Information

For the latest package outline information and land patterns (footprints), go to [www.maximintegrated.com/packages](http://www.maximintegrated.com/packages). Note that a “+”, “#”, or “-” in the package code indicates RoHS status only. Package drawings may show a different suffix character, but the drawing pertains to the package regardless of RoHS status.

PACKAGE TYPE	PACKAGE CODE	OUTLINE NO.	LAND PATTERN NO.
8 SOT23	K8SN+1	<a href="#">21-0078</a>	<a href="#">90-0176</a>
9 UCSP	B9+2	<a href="#">21-0093</a>	Refer to <a href="#">Application Note 1891</a>
12 UCSP	B12+1	<a href="#">21-0104</a>	Refer to <a href="#">Application Note 1891</a>
8 TDFN	T833+2	<a href="#">21-0137</a>	<a href="#">90-0059</a>
14 TDFN	T1433+2	<a href="#">21-0137</a>	<a href="#">90-0063</a>
14 TSSOP	U14+1	<a href="#">21-0066</a>	<a href="#">90-0113</a>

Pin 1 Indicator

Marking

AAAA

TOP VIEW

see Note 7

NOTES:

1. Terminal pitch is defined by terminal center to center value.
2. Outer dimension is defined by center lines between scribe lines.
3. All dimensions in millimeter.
4. Marking shown is for package orientation reference only.
5. Tolerance is ± 0.02 unless specified otherwise.
6. All dimensions apply to PbFree (+) package codes only.
7. Front - side finish can be either Black or Clear.

FRONT VIEW

BOTTOM VIEW

PKG. CODE	VARIABLE DIMENSIONS		DEPOPULATED SOLDER BALLS
	D	E	
B9-1	1.52±0.05	1.52±0.05	NONE
B9-2	1.52±0.05	1.52±0.05	B2
B9-3	1.52±0.05	1.52±0.05	B1, B2, B3
B9-4	1.60±0.05	1.60±0.05	NONE
B9-5	1.60±0.05	1.60±0.05	B2
B9-6	1.60±0.05	1.60±0.05	B1, B2, B3
B9-7	1.52±0.05	1.52±0.05	A2, B1, B2, B3, C2
B9-8	1.98±0.05	1.75±0.05	B1, B2, B3

COMMON DIMENSIONS	
A	0.64 ±0.05
A1	0.24 ±0.03
A2	0.40 REF
A3	0.04 BASIC
b	∅0.31 ±0.03
D1	1.00 BASIC
E1	1.00 BASIC
e	0.50 BASIC
SD	0.00 BASIC
SE	0.00 BASIC

DEPOPULATED BUMPS: see table on left

maxim integrated™

TITLE PACKAGE OUTLINE 9 BUMPS  
WLP PKG. 0.5 mm PITCH,

APPROVAL DOCUMENT CONTROL NO. 21-0093 REV. N 1/1

- DRAWING NOT TO SCALE -

MAX3372E–MAX3379E/  
MAX3390E–MAX3393E

±15kV ESD-Protected, 1µA, 16Mbps, Dual/Quad  
Low-Voltage Level Translators in UCSP

## Revision History



REVISION NUMBER	REVISION DATE	DESCRIPTION	PAGES CHANGED
0	1/02	Initial Release	—
1	12/06	Addition of 12-bump ECSP packaging	—
2	11/07	Addition of lead-free options	1, 20–31
3	1/13	Updated packaging information; updated <i>Absolute Maximum Ratings</i>	1, 2, 9, 20–23
4	2/15	Updated <i>Benefits and Features</i> section	1
5	10/19	Updated <i>Pin Description</i> table and added package outline drawing for 21-0093	9, 25
6	11/19	Updated <i>Benefits and Features</i> section	1
7	2/20	Updated <i>Ordering Information</i> table	20

For pricing, delivery, and ordering information, please visit Maxim Integrated's online storefront at <https://www.maximintegrated.com/en/storefront/storefront.html>.

Maxim Integrated cannot assume responsibility for use of any circuitry other than circuitry entirely embodied in a Maxim Integrated product. No circuit patent licenses are implied. Maxim Integrated reserves the right to change the circuitry and specifications without notice at any time. The parametric values (min and max limits) shown in the Electrical Characteristics table are guaranteed. Other parametric values quoted in this data sheet are provided for guidance.

## Looking for pricing, stock, or lifecycle information?

Click below to explore more details on WIN SOURCE:

-  [View MAX3373EEKA+T on WIN SOURCE](#)
-  [Maxim Integrated Information](#)

## Optimize Your Supply Chain with WIN SOURCE Solutions

-  Global Sourcing Solution
-  Obsolete Management
-  Cost Control Management
-  Shortage Management
-  Alternative Solution
-  Excess Inventory Management