



**THE DATASHEET OF  
MAX3203EETT+T**





# Low-Capacitance, 2/3/4/6-Channel, $\pm 15\text{kV}$ ESD Protection Arrays for High-Speed Data Interfaces

## General Description

The MAX3202E/MAX3203E/MAX3204E/MAX3206E are low-capacitance  $\pm 15\text{kV}$  ESD-protection diode arrays designed to protect sensitive electronics attached to communication lines. Each channel consists of a pair of diodes that steer ESD current pulses to VCC or GND. The MAX3202E/MAX3203E/MAX3204E/MAX3206E protect against ESD pulses up to  $\pm 15\text{kV}$  Human Body Model,  $\pm 8\text{kV}$  Contact Discharge, and  $\pm 15\text{kV}$  Air-Gap Discharge, as specified in IEC 61000-4-2. These devices have a 5pF capacitance per channel, making them ideal for use on high-speed data I/O interfaces.

The MAX3202E is a two-channel device intended for USB and USB 2.0 applications. The MAX3203E is a triple-ESD structure intended for USB On-the-Go (OTG) and video applications. The MAX3204E is a quad-ESD structure designed for Ethernet and FireWire® applications, and the MAX3206E is a six-channel device designed for cell phone connectors and SVGA video connections.

All devices are available in tiny 4-bump (1.05mm x 1.05mm) WLP, 6-bump (1.05mm x 1.57mm) WLP, 9-bump (1.52mm x 1.52mm) WLP, 6-pin (3mm x 3mm) TDFN, and 12-pin (4mm x 4mm) TQFN packages and are specified for  $-40^{\circ}\text{C}$  to  $+85^{\circ}\text{C}$  operation.

## Applications

USB	Video
USB 2.0	Cell Phones
Ethernet	SVGA Video Connections
FireWire	

## Selector Guide

PART	ESD-PROTECTED I/O PORTS
MAX3202EEWS+T	2
MAX3202EETT-T	2
MAX3203EEWT+T	3
MAX3203EETT-T	3
MAX3204EEBT-T	4
MAX3204EETT-T	4
MAX3206EEBL-T	6
MAX3206EETC	6

Pin Configurations appear at end of data sheet.

FireWire is a registered trademark of Apple Computer, Inc.



Maxim Integrated Products 1

For pricing, delivery, and ordering information, please contact Maxim Direct at 1-888-629-4642, or visit Maxim's website at [www.maxim-ic.com](http://www.maxim-ic.com).

## Features

- ◆ High-Speed Data Line ESD Protection
  - $\pm 15\text{kV}$ —Human Body Model
  - $\pm 8\text{kV}$ —IEC 61000-4-2, Contact Discharge
  - $\pm 15\text{kV}$ —IEC 61000-4-2, Air-Gap Discharge
- ◆ Tiny WLP Package Available
- ◆ Low 5pF Input Capacitance
- ◆ Low 1nA (max) Leakage Current
- ◆ Low 1nA Supply Current
- ◆ +0.9V to +5.5V Supply Voltage Range
- ◆ 2-, 3-, 4-, or 6-Channel Devices Available

## Ordering Information

PART	PIN-PACKAGE	TOP MARK
MAX3202EEWS+T	4 WLP	+AA
MAX3202EETT+T	6 TDFN-EP*	+ADQ
MAX3203EEWT+T	6 WLP	+BG
MAX3203EETT+T	6 TDFN-EP*	+ADO
MAX3204EEWT+T	6 WLP	+AL
MAX3204EETT+T	6 TDFN-EP*	+ADP
MAX3206EEWL+T	9 WLP	+AQ
MAX3206EETC+	12 TQFN-EP*	+ACA

\*EP = Exposed pad.

**Note:** All devices operate over  $-40^{\circ}\text{C}$  to  $+85^{\circ}\text{C}$  temperature range.

+Denotes a lead(Pb)-free/RoHS-compliant package.

## Typical Operating Circuit

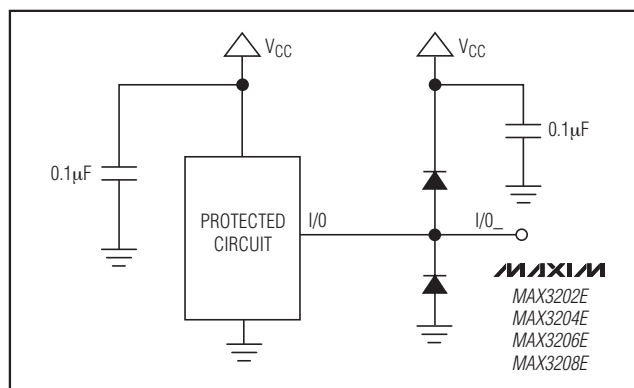

MAX3202E/MAX3203E/MAX3204E/MAX3206E

# Low-Capacitance, 2/3/4/6-Channel, ±15kV ESD Protection Arrays for High-Speed Data Interfaces

## ABSOLUTE MAXIMUM RATINGS

V <sub>CC</sub> to GND .....	-0.3V to +7.0V	6-Pin TDFN (derate 24.4mW/°C above +70°C) .....	1951mW
I/O <sub>-</sub> to GND .....	-0.3V to (V <sub>CC</sub> + 0.3V)	12-Pin TQFN (derate 16.9mW/°C above +70°C) .....	1349mW
Continuous Power Dissipation (T <sub>A</sub> = +70°C)		Operating Temperature Range .....	-40°C to +85°C
2 × 2 WLP (derate 11.5mW/°C above +70°C).....	920mW	Storage Temperature Range .....	-65°C to +150°C
3 × 2 WLP (derate 12.3mW/°C above +70°C).....	984mW	Junction Temperature .....	+150°C
3 × 3 WLP (derate 14.1mW/°C above +70°C).....	1128mW	Lead Temperature (soldering, 10s) .....	+300°C
		Soldering Temperature (reflow) .....	+260°C

Stresses beyond those listed under "Absolute Maximum Ratings" may cause permanent damage to the device. These are stress ratings only, and functional operation of the device at these or any other conditions beyond those indicated in the operational sections of the specifications is not implied. Exposure to absolute maximum rating conditions for extended periods may affect device reliability.

## PACKAGE THERMAL CHARACTERISTICS (Note 1)

4 WLP	Junction-to-Ambient Thermal Resistance (θ <sub>JA</sub> ).....	87°C/W	6 TDFN	Junction-to-Ambient Thermal Resistance (θ <sub>JA</sub> ).....	42°C/W
6 WLP	Junction-to-Ambient Thermal Resistance (θ <sub>JA</sub> ).....	84°C/W		Junction-to-Case Thermal Resistance (θ <sub>JC</sub> ).....	9°C/W
9 WLP	Junction-to-Ambient Thermal Resistance (θ <sub>JA</sub> ).....	71°C/W	12 TQFN	Junction-to-Ambient Thermal Resistance (θ <sub>JA</sub> ).....	41°C/W
				Junction-to-Case Thermal Resistance (θ <sub>JC</sub> ).....	6°C/W

**Note 1:** Package thermal resistances were obtained using the method described in JEDEC specification JESD51-7, using a four-layer board. For detailed information on package thermal considerations, refer to [www.maxim-ic.com/thermal-tutorial](http://www.maxim-ic.com/thermal-tutorial).

## ELECTRICAL CHARACTERISTICS

(V<sub>CC</sub> = +5V ±5%, T<sub>A</sub> = T<sub>MIN</sub> to T<sub>MAX</sub>, unless otherwise noted. Typical values are at V<sub>CC</sub> = +5V and T<sub>A</sub> = +25°C.) (Note 2)

PARAMETER	SYMBOL	CONDITIONS	MIN	TYP	MAX	UNITS
Supply Voltage	V <sub>CC</sub>		0.9		5.5	V
Supply Current	I <sub>CC</sub>			1	100	nA
Diode Forward Voltage	V <sub>F</sub>	I <sub>F</sub> = 10mA	0.65		0.95	V
Channel Clamp Voltage (Note 3)	V <sub>C</sub>	T <sub>A</sub> = +25°C, ±15kV Human Body Model, I <sub>F</sub> = 10A	Positive transients		V <sub>CC</sub> + 25	V
			Negative transients		-25	
		T <sub>A</sub> = +25°C, ±8kV Contact Discharge (IEC 61000-4-2), I <sub>F</sub> = 24A	Positive transients		V <sub>CC</sub> + 60	
			Negative transients		-60	
		T <sub>A</sub> = +25°C, ±15kV Air-Gap Discharge (IEC 61000-4-2), I <sub>F</sub> = 45A	Positive transients		V <sub>CC</sub> + 100	
			Negative transients		-100	
Channel Leakage Current		T <sub>A</sub> = 0°C to +50°C (Note 4)	-1		+1	nA
Channel Input Capacitance		V <sub>CC</sub> = 5V, bias of V <sub>CC</sub> /2		5	7	pF
<b>ESD PROTECTION</b>						
Human Body Model				±15		kV
IEC 61000-4-2 Contact Discharge				±8		kV
IEC 61000-4-2 Air-Gap Discharge				±15		kV

**Note 2:** Limits over temperature are guaranteed by design, not production tested.

**Note 3:** Idealized clamp voltages (L1 = L2 = L3 = 0) (Figure 1 ); see the *Applications Information* section for more information.

**Note 4:** Guaranteed by design. Not production tested.

# Low-Capacitance, 2/3/4/6-Channel, ±15kV ESD Protection Arrays for High-Speed Data Interfaces

## Typical Operating Characteristics

(V<sub>CC</sub> = +5V, T<sub>A</sub> = +25°C, unless otherwise noted.)

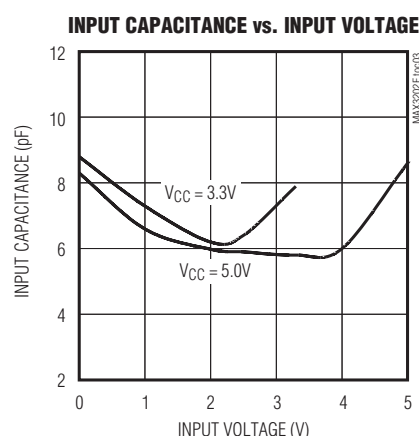
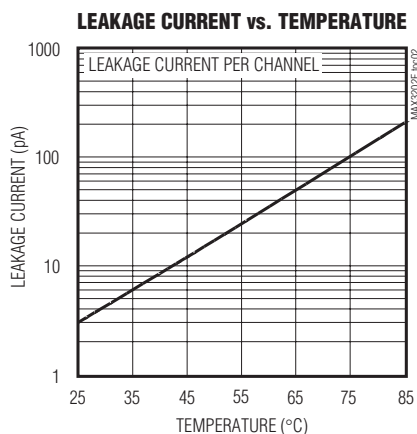
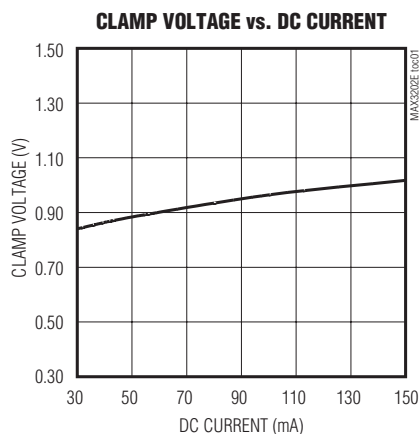

## Pin/Bump Description

PIN/BUMP								NAME	FUNCTION
MAX3202E		MAX3203E		MAX3204E		MAX3206E			
WLP	TDFN-EP	WLP	TDFN-EP	WLP	TDFN-EP	WLP	TQFN-EP		
A1, B2	3, 6	A1, A2, B3	1, 2, 4	A1, A2, B2, B3	1, 2, 4, 5	A1, A3, B1, B3, C1, C3	1, 2, 3, 7, 8, 9	I/O <sub>-</sub>	ESD-Protected Channel
A2	4	B1	3	B1	3	A2	5	GND	Ground
B1	1	A3	6	A3	6	C2	11	V <sub>CC</sub>	Power-Supply Input. Bypass V <sub>CC</sub> to GND with a 0.1μF ceramic capacitor.
—	2, 5	—	5	—	—	—	4, 6, 10, 12	N.C.	No Connection. Not internally connected.
—	—	—	—	—	—	—	—	EP	Exposed Pad. Connect to GND. Only for TDFN and TQFN packages.

MAX3202E/MAX3203E/MAX3204E/MAX3206E

# Low-Capacitance, 2/3/4/6-Channel, ±15kV ESD Protection Arrays for High-Speed Data Interfaces

## Detailed Description

The MAX3202E/MAX3203E/MAX3204E/MAX3206E are diode arrays designed to protect sensitive electronics against damage resulting from ESD conditions or transient voltages. The low input capacitance makes these devices ideal for high-speed data lines. The MAX3202E, MAX3203E, MAX3204E, and MAX3206E protect two, three, four, and six channels, respectively.

The MAX3202E/MAX3203E/MAX3204E/MAX3206E are designed to work in conjunction with a device's intrinsic ESD protection. The MAX3202E/MAX3203E/MAX3204E/MAX3206E limit the excursion of the ESD event to below ±25V peak voltage when subjected to the Human Body Model waveform. When subjected to the IEC 61000-4-2 waveform, the peak voltage is limited to ±60V when subjected to Contact Discharge and ±100V when subjected to Air-Gap Discharge. The device that is being protected by the MAX3202E/MAX3203E/MAX3204E/MAX3206E must be able to withstand these peak voltages plus any additional voltage generated by the parasitic board.

## Applications Information

### Design Considerations

Maximum protection against ESD damage results from proper board layout (see the *Layout Recommendations* section and Figure 2). A good layout reduces the parasitic series inductance on the ground line, supply line, and protected signal lines.

The MAX3202E/MAX3203E/MAX3204E/MAX3206E ESD diodes clamp the voltage on the protected lines during an ESD event and shunt the current to GND or V<sub>CC</sub>. In an ideal circuit, the clamping voltage, V<sub>C</sub>, is defined as the forward voltage drop, V<sub>F</sub>, of the protection diode plus any supply voltage present on the cathode.

For positive ESD pulses:

$$V_C = V_{CC} + V_F$$

For negative ESD pulses:

$$V_C = -V_F$$

In reality, the effect of the parasitic series inductance on the lines must also be considered (Figure 1).

For positive ESD pulses:

$$V_C = V_{CC} + V_{F(D1)} + \left( L1 \times \frac{d(I_{ESD})}{dt} \right) + \left( L2 \times \frac{d(I_{ESD})}{dt} \right)$$

For negative ESD pulses:

$$V_C = - \left( V_{F(D2)} + \left( L1 \times \frac{d(I_{ESD})}{dt} \right) + \left( L3 \times \frac{d(I_{ESD})}{dt} \right) \right)$$

where I<sub>ESD</sub> is the ESD current pulse.

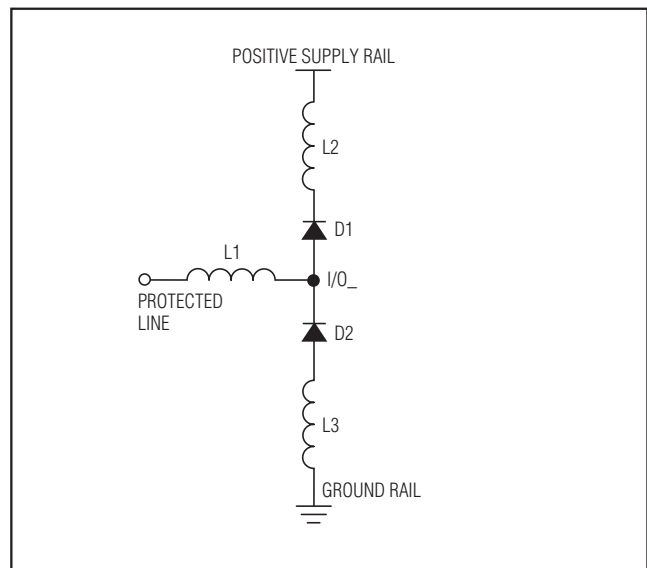

Figure 1. Parasitic Series Inductance

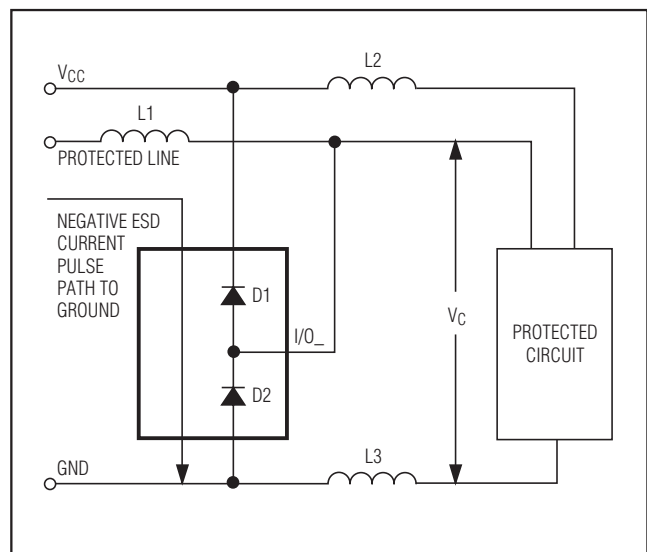

Figure 2. Layout Considerations

# Low-Capacitance, 2/3/4/6-Channel, ±15kV ESD Protection Arrays for High-Speed Data Interfaces

During an ESD event, the current pulse rises from zero to peak value in nanoseconds (Figure 3). For example, in a 15kV IEC-61000 Air-Gap Discharge ESD event, the pulse current rises to approximately 45A in 1ns ( $di/dt = 45 \times 10^9$ ). An inductance of only 10nH adds an additional 450V to the clamp voltage. An inductance of 10nH represents approximately 0.5in of board trace. Regardless of the device's specified diode clamp voltage, a poor layout with parasitic inductance significantly increases the effective clamp voltage at the protected signal line.

A low-ESR 0.1µF capacitor must be used between VCC and GND. This bypass capacitor absorbs the charge transferred by an +8kV IEC-61000 Contact Discharge ESD event.

Ideally, the supply rail (VCC) would absorb the charge caused by a positive ESD strike without changing its regulated value. In reality, all power supplies have an effective output impedance on their positive rails. If a power supply's effective output impedance is 1Ω, then by using  $V = I \times R$ , the clamping voltage of VC increases by the equation  $V_C = I_{ESD} \times R_{OUT}$ . An +8kV IEC 61000-4-2 ESD event generates a current spike of 24A, so the clamping voltage increases by  $V_C = 24A \times 1\Omega$ , or  $V_C = 24V$ . Again, a poor layout without proper bypassing increases the clamping voltage. A ceramic chip capacitor mounted as close to the MAX3202E/MAX3203E/MAX3204E/MAX3206E VCC pin is the best choice for this application. A bypass capacitor should also be placed as close to the protected device as possible.

## ±15kV ESD Protection

ESD protection can be tested in various ways; the MAX3202E/MAX3203E/MAX3204E/MAX3206E are characterized for protection to the following limits:

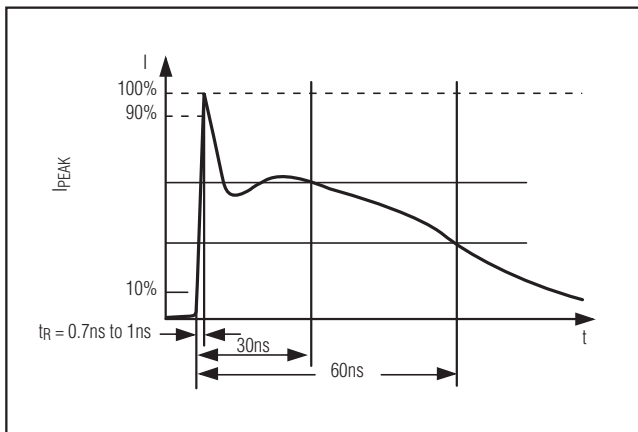

Figure 3. IEC 61000-4-2 ESD Generator Current Waveform

- ±15kV using the Human Body Model
- ±8kV using the Contact Discharge method specified in IEC 61000-4-2
- ±15kV using the IEC 61000-4-2 Air-Gap Discharge method

## ESD Test Conditions

ESD performance depends on a number of conditions. Contact Maxim for a reliability report that documents test setup, methodology, and results.

## Human Body Model

Figure 4 shows the Human Body Model, and Figure 5 shows the current waveform it generates when discharged into a low impedance. This model consists of a 100pF capacitor charged to the ESD voltage of interest, which is then discharged into the device through a 1.5kΩ resistor.

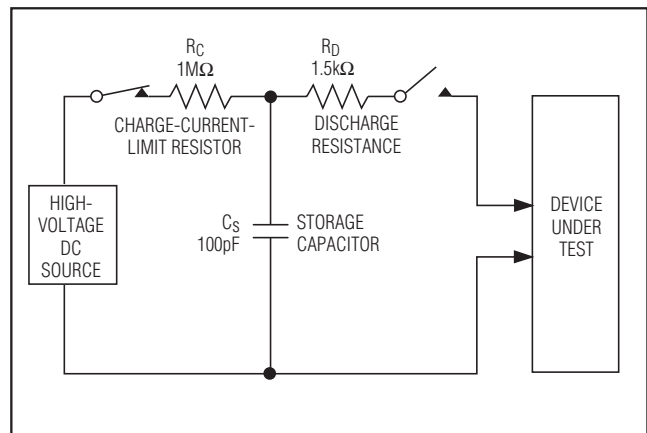

Figure 4. Human Body ESD Test Model

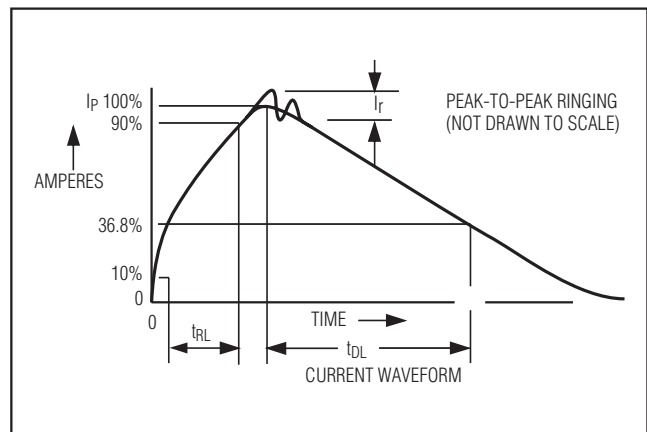

Figure 5. Human Body Model Current Waveform

## Low-Capacitance, 2/3/4/6-Channel, $\pm 15\text{kV}$ ESD Protection Arrays for High-Speed Data Interfaces

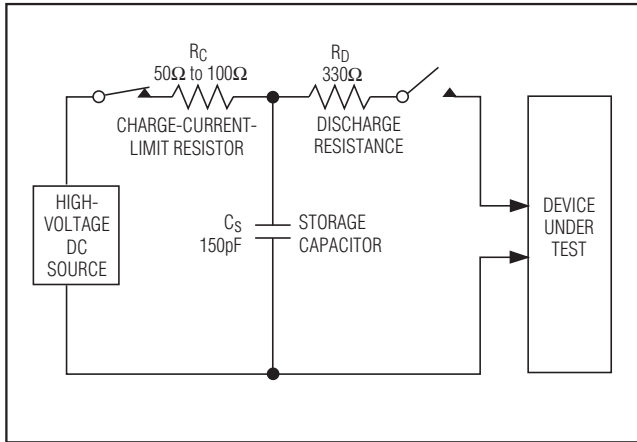

Figure 6. IEC 61000-4-2 ESD Test Model

### IEC 61000-4-2

The IEC 61000-4-2 standard covers ESD testing and performance of finished equipment. The MAX3202E/MAX3203E/MAX3204E/MAX3206E help users design equipment that meets Level 4 of IEC 61000-4-2.

The main difference between tests done using the Human Body Model and IEC 61000-4-2 is higher peak current in IEC 61000-4-2. Because series resistance is lower in the IEC 61000-4-2 ESD test model (Figure 6) the ESD-withstand voltage measured to this standard is generally lower than that measured using the Human Body Model. Figure 3 shows the current waveform for the  $\pm 8\text{kV}$  IEC 61000-4-2 Level 4 ESD Contact Discharge test.

The Air-Gap Discharge test involves approaching the device with a charged probe. The Contact Discharge method connects the probe to the device before the probe is energized.

### Layout Recommendations

Proper circuit-board layout is critical to suppress ESD-induced line transients. The MAX3202E/MAX3203E/MAX3204E/MAX3206E clamp to 100V; however, with improper layout, the voltage spike at the device is much higher. A lead inductance of 10nH with a 45A current spike at a  $dv/dt$  of 1ns results in an **ADDITIONAL** 450V spike on the protected line. It is **essential** that the layout of the PC board follows these guidelines:

- 1) Minimize trace length between the connector or input terminal, I/O\_, and the protected signal line.
- 2) Use separate planes for power and ground to reduce parasitic inductance and to reduce the impedance to the power rails for shunted ESD current.
- 3) Ensure short ESD transient return paths to GND and VCC.
- 4) Minimize conductive power and ground loops.
- 5) Do not place critical signals near the edge of the PC board.
- 6) Bypass VCC to GND with a low-ESR ceramic capacitor as close to VCC as possible.
- 7) Bypass the supply of the protected device to GND with a low-ESR ceramic capacitor as close to the supply pin as possible.

# Low-Capacitance, 2/3/4/6-Channel, ±15kV ESD Protection Arrays for High-Speed Data Interfaces

Table 1. Reliability Test Data

TEST	CONDITIONS	DURATION	FAILURES PER SAMPLE SIZE
Temperature Cycle	-35°C to +85°C, -40°C to +100°C	150 cycles, 900 cycles	0/10, 0/200
Operating Life	T <sub>A</sub> = +70°C	240hr	0/10
Moisture Resistance	-20°C to +60°C, 90% RH	240hr	0/10
Low-Temperature Storage	-20°C	240hr	0/10
Low-Temperature Operational	-10°C	24hr	0/10
Solderability	8hr steam age	—	0/15
ESD	±2000V, Human Body Model	—	0/5
High-Temperature Operating Life	T <sub>J</sub> = +150°C	168hr	0/45

## Functional Diagrams

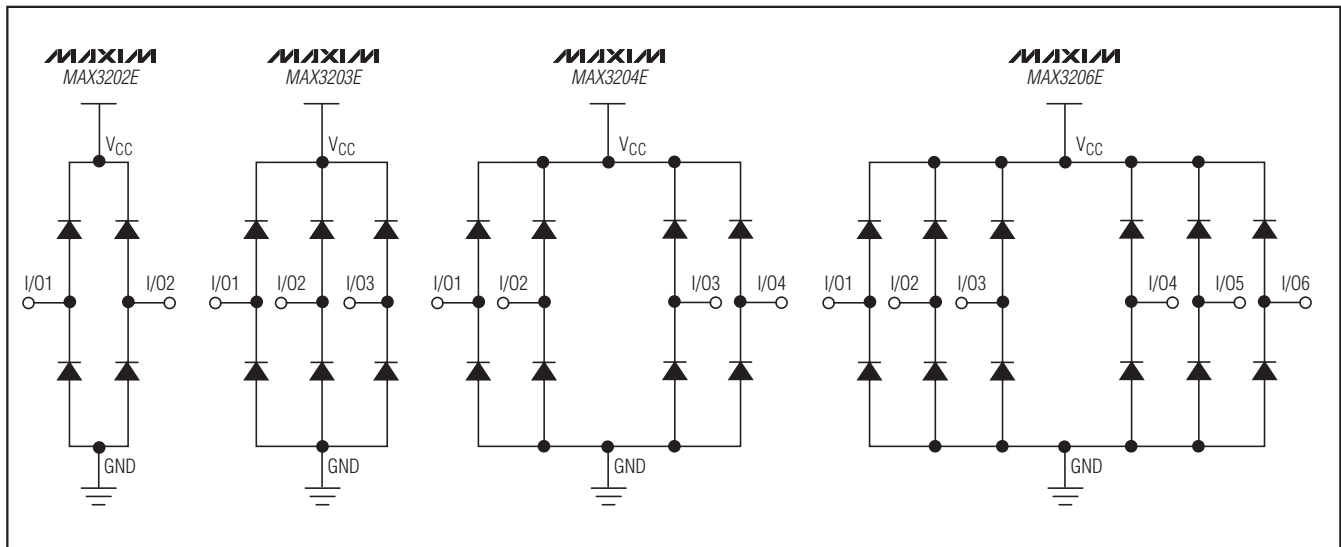

## Chip Information

PROCESS: BiCMOS

# Low-Capacitance, 2/3/4/6-Channel, ±15kV ESD Protection Arrays for High-Speed Data Interfaces

## Pin Configurations

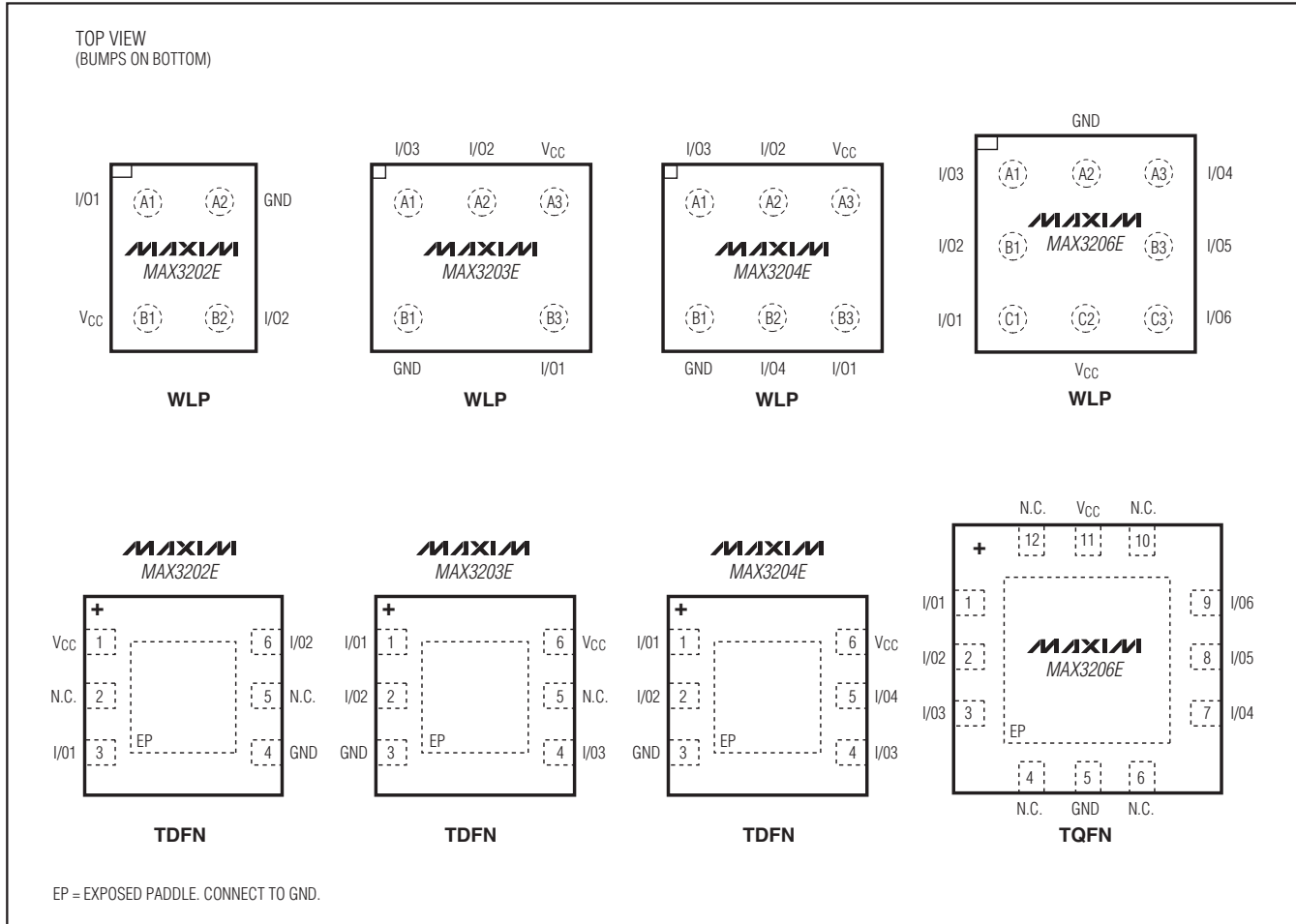

## Package Information

For the latest package outline information and land patterns (footprints), go to [www.maxim-ic.com/packages](http://www.maxim-ic.com/packages). Note that a "+", "#", or "-" in the package code indicates RoHS status only. Package drawings may show a different suffix character, but the drawing pertains to the package regardless of RoHS status.

PACKAGE TYPE	PACKAGE CODE	OUTLINE NO.	LAND PATTERN NO.
4 WLP	W41A1+2	<a href="#">21-0455</a>	Refer to <a href="#">Application Note 1891</a>
6 WLP	W61C1+2	<a href="#">21-0463</a>	Refer to <a href="#">Application Note 1891</a>
9 WLP	W91B1+5	<a href="#">21-0067</a>	Refer to <a href="#">Application Note 1891</a>
6 TDFN-EP	T633+2	<a href="#">21-0137</a>	<a href="#">90-0058</a>
12 TQFN-EP	T1244+4	<a href="#">21-0139</a>	<a href="#">90-0068</a>

# Low-Capacitance, 2/3/4/6-Channel, ±15kV ESD Protection Arrays for High-Speed Data Interfaces

## Revision History

REVISION NUMBER	REVISION DATE	DESCRIPTION	PAGES CHANGED
3	12/07	Added 3202EEWS+T TDFN and TQFN packages, updated Package Information	1, 2, 3, 4, 6, 8, 12-15
4	12/09	Corrected part numbers and pin packages in the <i>Ordering Information</i> table, <i>Absolute Maximum Ratings</i> , <i>Selector Guide</i> , <i>Pin Description</i> , and <i>Pin Configurations</i> .	1-3, 8-15
5	6/11	Updated to show available packages as WLP, not UCSP	1, 2, 3, 6, 8

MAX3202E/MAX3203E/MAX3204E/MAX3206E

Maxim cannot assume responsibility for use of any circuitry other than circuitry entirely embodied in a Maxim product. No circuit patent licenses are implied. Maxim reserves the right to change the circuitry and specifications without notice at any time.

Maxim Integrated Products, 120 San Gabriel Drive, Sunnyvale, CA 94086 408-737-7600 \_\_\_\_\_ 9

## Looking for pricing, stock, or lifecycle information?

Click below to explore more details on WIN SOURCE:

- ⊖ [View MAX3203EETT+T on WIN SOURCE](#)
- ⊖ [Maxim Integrated Information](#)

## Optimize Your Supply Chain with WIN SOURCE Solutions

- ✓ Global Sourcing Solution
- ✓ Obsolete Management
- ✓ Cost Control Management
- ✓ Shortage Management
- ✓ Alternative Solution
- ✓ Excess Inventory Management