



THE DATASHEET OF MAX2620EUA



EVALUATION KIT
AVAILABLE

MAXIM

10MHz to 1050MHz Integrated RF Oscillator with Buffered Outputs

MAX2620

General Description

The MAX2620 combines a low-noise oscillator with two output buffers in a low-cost, plastic surface-mount, ultra-small μ MAX package. This device integrates functions typically achieved with discrete components. The oscillator exhibits low-phase noise when properly mated with an external varactor-tuned resonant tank circuit. Two buffered outputs are provided for driving mixers or prescalers. The buffers provide load isolation to the oscillator and prevent frequency pulling due to load-impedance changes. Power consumption is typically just 27mW in operating mode ($V_{CC} = 3.0V$), and drops to less than 0.3 μ W in standby mode. The MAX2620 operates from a single +2.7V to +5.25V supply.

Applications

Analog Cellular Phones
Digital Cellular Phones
900MHz Cordless Phones
900MHz ISM-Band Applications
Land Mobile Radio
Narrowband PCS (NPCS)

Features

- ◆ Low-Phase-Noise Oscillator: -110dBc/Hz (25kHz offset from carrier) Attainable
- ◆ Operates from Single +2.7V to +5.25V Supply
- ◆ Low-Cost Silicon Bipolar Design
- ◆ Two Output Buffers Provide Load Isolation
- ◆ Insensitive to Supply Variations
- ◆ Low, 27mW Power Consumption ($V_{CC} = 3.0V$)
- ◆ Low-Current Shutdown Mode: 0.1 μ A (typ)

Ordering Information

PART	TEMP RANGE	PIN-PACKAGE
MAX2620EUA	-40°C to +85°C	8 μ MAX
MAX2620E/D	-40°C to +85°C	Dice*

*Dice are tested at $T_A = +25^\circ\text{C}$, DC parameters only.

Pin Configuration appears at end of data sheet.

Typical Operating Circuit

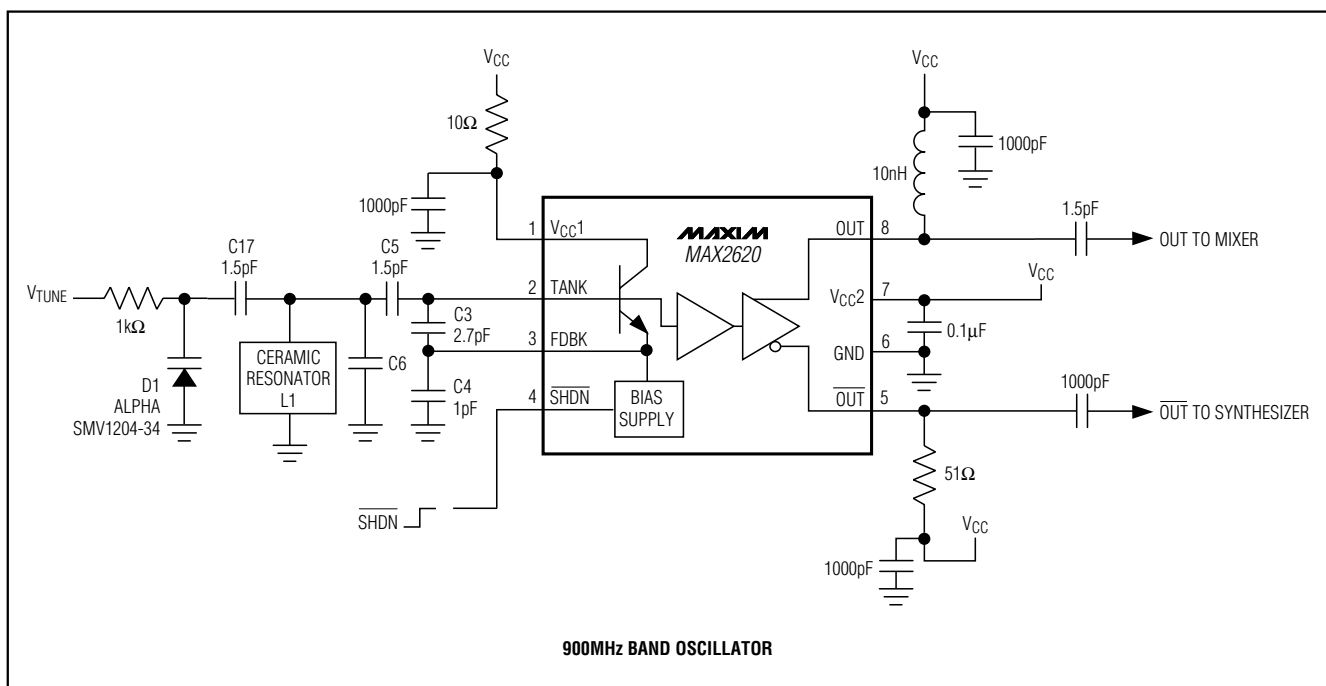

MAXIM

Maxim Integrated Products 1

For pricing, delivery, and ordering information, please contact Maxim/Dallas Direct! at 1-888-629-4642, or visit Maxim's website at www.maxim-ic.com.

10MHz to 1050MHz Integrated RF Oscillator with Buffered Outputs

ABSOLUTE MAXIMUM RATINGS

V _{CC1} , V _{CC2} to GND	-0.3V to +6V	Operating Temperature Range	
TANK, $\overline{\text{SHDN}}$ to GND	-0.3V to (V _{CC} + 0.3V)	MAX2620EUA	-40°C to +85°C
OUT, $\overline{\text{OUT}}$ to GND	(V _{CC} - 0.6V) to (V _{CC} + 0.3V)	Junction Temperature	+150°C
FDBK to GND	(V _{CC} - 2.0V) to (V _{CC} + 0.3V)	Storage Temperature Range	-65°C to +165°C
Continuous Power Dissipation (T _A = +70°C)		Lead Temperature (soldering, 10s)	+300°C
μMAX (derate 5.7mW/°C above +70°C)	457mW		

Stresses beyond those listed under "Absolute Maximum Ratings" may cause permanent damage to the device. These are stress ratings only, and functional operation of the device at these or any other conditions beyond those indicated in the operational sections of the specifications is not implied. Exposure to absolute maximum rating conditions for extended periods may affect device reliability.

DC ELECTRICAL CHARACTERISTICS

(V_{CC1}, V_{CC2} = +2.7V to +5.25V, FDBK = open, TANK = open, OUT and $\overline{\text{OUT}}$ connected to V_{CC} through 50Ω, $\overline{\text{SHDN}}$ = 2V, T_A = -40°C to +85°C, unless otherwise noted. Typical values measured at V_{CC1} = V_{CC2} = 3.0V, T_A = +25°C.) (Note 1)

PARAMETER	CONDITIONS	MIN	TYP	MAX	UNITS
Supply Current			9.0	12.5	mA
Shutdown Current	$\overline{\text{SHDN}}$ = 0.6V		0.1	2	μA
Shutdown Input Voltage High		2.0			V
Shutdown Input Voltage Low				0.6	V
Shutdown Bias Current High	$\overline{\text{SHDN}}$ = 2.0V		5.5	20	μA
Shutdown Bias Current Low	$\overline{\text{SHDN}}$ = 0.6V			0.5	μA

Note 1: Specifications are production tested and guaranteed at T_A = +25°C and T_A = +85°C. Specifications are guaranteed by design and characterization at T_A = -40°C.

AC ELECTRICAL CHARACTERISTICS

(Test Circuit of Figure 1, V_{CC} = +3.0V, $\overline{\text{SHDN}}$ = V_{CC}, Z_{LOAD} = Z_{SOURCE} = 50Ω, P_{IN} = -20dBm (50Ω), f_{TEST} = 900MHz, T_A = +25°C, unless otherwise noted.)

PARAMETER	CONDITIONS	MIN	TYP	MAX	UNITS
Frequency Range	T _A = -40°C to +85°C (Note 2)	10		1050	MHz
Reverse Isolation	OUT or $\overline{\text{OUT}}$ to TANK; OUT, $\overline{\text{OUT}}$ driven at P = -20dBm		50		dB
Output Isolation	OUT to $\overline{\text{OUT}}$		33		dB

Note 2: Guaranteed by design and characterization at 10MHz, 650MHz, 900MHz, and 1050MHz. Over this frequency range, the magnitude of the negative real impedance measured at TANK is greater than one-tenth the magnitude of the reactive impedances at TANK. This implies proper oscillator start-up when using an external resonator tank circuit with Q > 10. C3 and C4 must be tuned for operation at the desired frequency.

10MHz to 1050MHz Integrated RF Oscillator with Buffered Outputs

MAX2620

TYPICAL OPERATING CIRCUIT PERFORMANCE—900MHz Band Ceramic-Resonator-Based Tank

(Typical Operating Circuit, $V_{CC} = +3.0V$, $V_{TUNE} = 1.5V$, $\overline{SHDN} = V_{CC}$, load at OUT = 50 Ω , load at \overline{OUT} = 50 Ω , L1 = coaxial ceramic resonator: Trans-Tech SR8800LPQ1357BY, C6 = 1pF, $T_A = +25^\circ C$, unless otherwise noted.)

PARAMETER	CONDITIONS	MIN	TYP	MAX	UNITS
Tuning Range	$V_{TUNE} = 0.5V$ to 3.0V		± 13		MHz
Phase Noise	SSB at $\Delta f = 25kHz$		-110		dBc/Hz
	SSB at $\Delta f = 300kHz$		-132		
Output Power (Single-Ended)	At OUT (Note 2)	-6	-2		dBm
	At OUT, per test circuit of Figure 1; $T_A = -40^\circ C$ to $+85^\circ C$ (Note 3)	-11	-8		
	At \overline{OUT} (Note 3)	-16	-12.5		
Noise Power	$f_0 \pm >10MHz$		-147		dBm/Hz
Average Tuning Gain			11		MHz/V
Second-Harmonic Output			-29		dBc
Load Pull	VSWR = 1.75:1, all phases		163		kHz _{p-p}
Supply Pushing	V_{CC} stepped from 3V to 4V		71		kHz/V

Note 3: Guaranteed by design and characterization.

TYPICAL OPERATING CIRCUIT PERFORMANCE—900MHz Band Inductor-Based Tank

(Typical Operating Circuit, $V_{CC} = +3.0V$, $V_{TUNE} = 1.5V$, $\overline{SHDN} = V_{CC}$, load at OUT = 50 Ω , load at \overline{OUT} = 50 Ω , L1 = 5nH (Coilcraft A02T), C6 = 1.5pF, $T_A = +25^\circ C$, unless otherwise noted.)

PARAMETER	CONDITIONS	MIN	TYP	MAX	UNITS
Tuning Range	$V_{TUNE} = 0.5V$ to 3.0V		± 15		MHz
Phase Noise	SSB at $\Delta f = 25kHz$		-107		dBc/Hz
	SSB at $\Delta f = 300kHz$		-127		
Output Power (single-ended)	At OUT (Note 2)	-6	-2		dBm
	At OUT, per test circuit of Figure 1; $T_A = -40^\circ C$ to $+85^\circ C$ (Note 3)	-11	-8		
	At \overline{OUT} (Note 3)	-16	-12.5		
Noise Power	$f_0 \pm >10MHz$		-147		dBm/Hz
Average Tuning Gain			13		MHz/V
Second-Harmonic Output			-29		dBc
Load Pull	VSWR = 1.75:1, all phase angles		340		kHz _{p-p}
Supply Pushing	V_{CC} stepped from 3V to 4V		150		kHz/V

Note 3: Guaranteed by design and characterization.

10MHz to 1050MHz Integrated RF Oscillator with Buffered Outputs

Typical Operating Characteristics

(Test Circuit of Figure 1, $V_{CC} = +3.0V$, $\overline{SHDN} = V_{CC}$, $Z_{LOAD} = Z_{SOURCE} = 50\Omega$, $P_{IN} = -20dBm/50\Omega$, $f_{TEST} = 900MHz$, $T_A = +25^\circ C$, unless otherwise noted.)

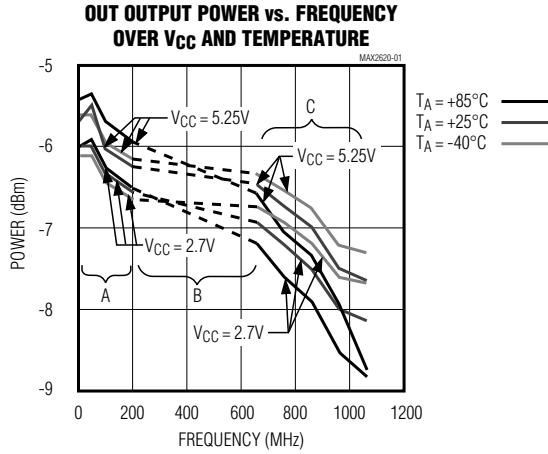

A: 10MHz BAND CIRCUIT
B: NOT CHARACTERIZED FOR THIS FREQUENCY BAND.
EXPECTED PERFORMANCE SHOWN.
C: 900MHz BAND CIRCUIT

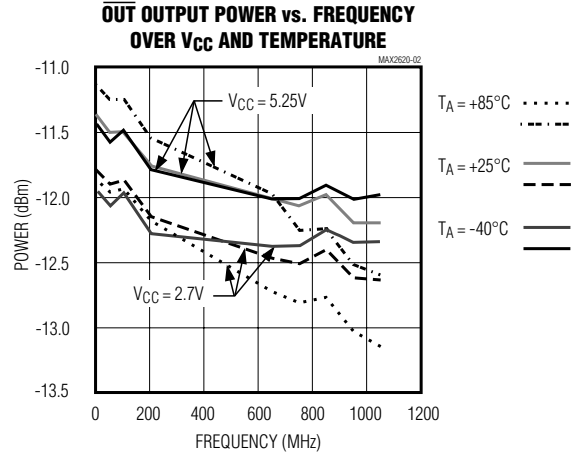

Table 1. Recommended Load Impedance at OUT or \overline{OUT} for Optimum Power Transfer

FREQUENCY (MHz)	REAL COMPONENT (R in Ω)	IMAGINARY COMPONENT (X in Ω)
250	106	163
350	68	102
450	60	96
550	35	79
650	17.5	62.3
750	17.2	50.6
850	10.9	33.1
950	7.3	26.3
1050	6.5	22.7

10MHz to 1050MHz Integrated RF Oscillator with Buffered Outputs

MAX2620

Typical Operating Characteristics (continued)

(Typical Operating Circuit, $V_{CC} = +3.0V$, $V_{TUNE} = 1.5V$, $\overline{SHDN} = V_{CC}$, load at OUT = 50Ω , load at $\overline{OUT} = 50\Omega$, L1 = coaxial ceramic resonator: Trans-Tech SR8800LPQ1357BY, C6 = 1pF, $T_A = +25^\circ C$, unless otherwise noted.)

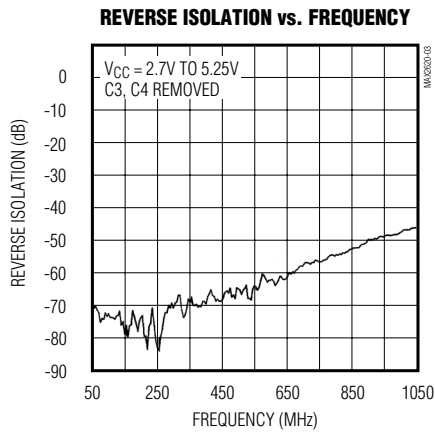

900MHz BAND CIRCUIT*
TYPICAL $1/S_{11}$ vs. FREQUENCY
MEASURED AT TEST PORT

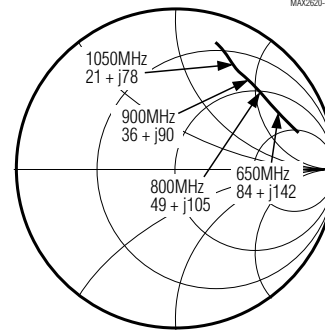

*SEE FIGURE 1

10MHz BAND CIRCUIT
TYPICAL $1/S_{11}$ vs. FREQUENCY
MEASURED AT TEST PORT

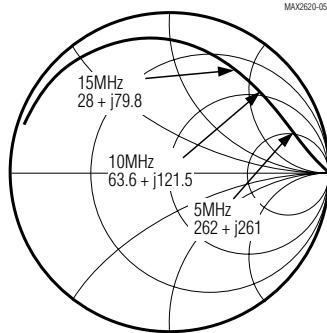

C3 = C4 = 270pF
L3 = 10 μ H
C2 = C10 = C13 = 0.01 μ F

SUPPLY CURRENT vs. TEMPERATURE

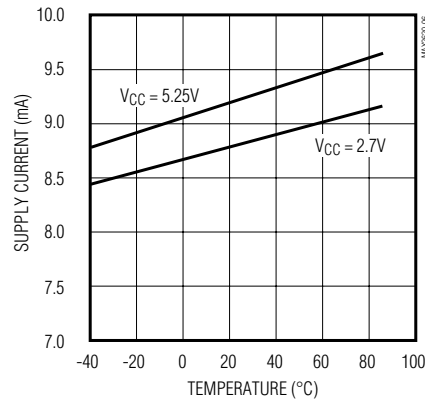

10MHz to 1050MHz Integrated RF Oscillator with Buffered Outputs

Typical Operating Characteristics (continued)

(Typical Operating Circuit, $V_{CC} = +3.0V$, $V_{TUNE} = 1.5V$, $\overline{SHDN} = V_{CC}$, load at $\overline{OUT} = 50\Omega$, load at $OUT = 50\Omega$, $L1 =$ coaxial ceramic resonator: Trans-Tech SR8800LPQ1357BY, $C6 = 1pF$, $T_A = +25^\circ C$, unless otherwise noted.)

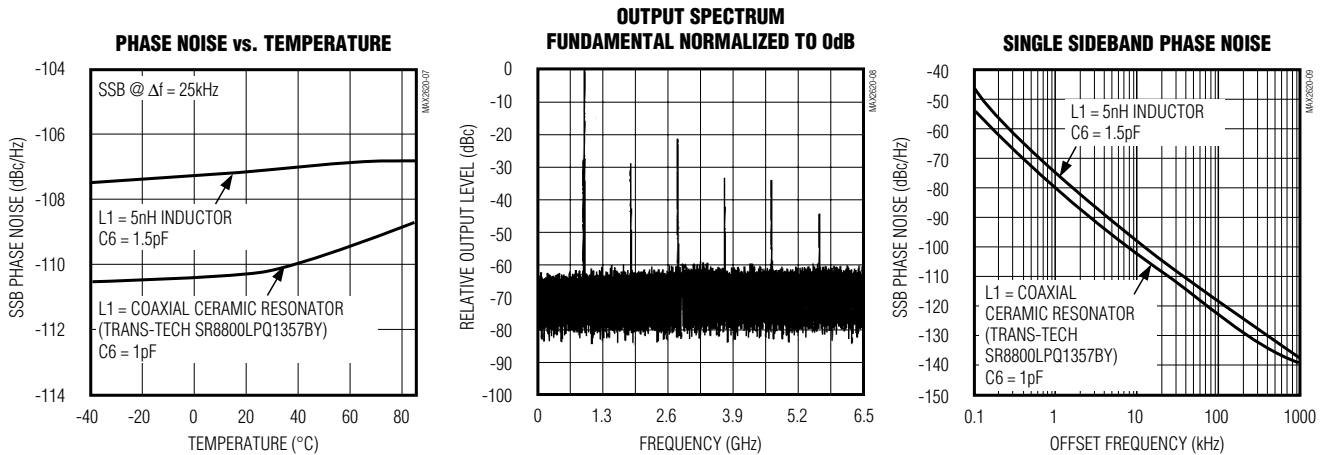

Pin Description

PIN	NAME	FUNCTION
1	VCC1	Oscillator DC Supply Voltage. Decouple VCC1 with 1000pF capacitor to ground. Use a capacitor with low series inductance (size 0805 or smaller). Further power-supply decoupling can be achieved by adding a 10Ω resistor in series from VCC1 to the supply. Proper power-supply decoupling is critical to the low noise and spurious performance of any oscillator.
2	TANK	Oscillator Tank Circuit Connection. Refer to the <i>Applications Information</i> section.
3	FDBK	Oscillator Feedback Circuit Connection. Connecting capacitors of the appropriate value between FDBK and TANK and between FDBK and GND tunes the oscillator's reflection gain (negative resistance) to peak at the desired oscillation frequency. Refer to the <i>Applications Information</i> section.
4	\overline{SHDN}	Logic-Controlled Input. A low level turns off the entire circuitry such that the IC will draw only leakage current at its supply pins. This is a high-impedance input.
5	\overline{OUT}	Open-Collector Output Buffer (complement). Requires external pull-up to the voltage supply. Pull-up can be resistor, choke, or inductor (which is part of a matching network). The matching-circuit approach provides the highest-power output and greatest efficiency. Refer to Table 1 and the <i>Applications Information</i> section. \overline{OUT} can be used with OUT in a differential output configuration.
6	GND	Ground Connection. Provide a low-inductance connection to the circuit ground plane.
7	VCC2	Output Buffer DC Supply Voltage. Decouple VCC2 with a 1000pF capacitor to ground. Use a capacitor with low series inductance (size 0805 or smaller).
8	OUT	Open-Collector Output Buffer. Requires external pull-up to the voltage supply. Pull-up can be resistor, choke, or inductor (which is part of a matching network). The matching-circuit approach provides the highest-power output and greatest efficiency. Refer to Table 1 and the <i>Applications Information</i> section. OUT can be used with \overline{OUT} in a differential output configuration.

10MHz to 1050MHz Integrated RF Oscillator with Buffered Outputs

MAX2620

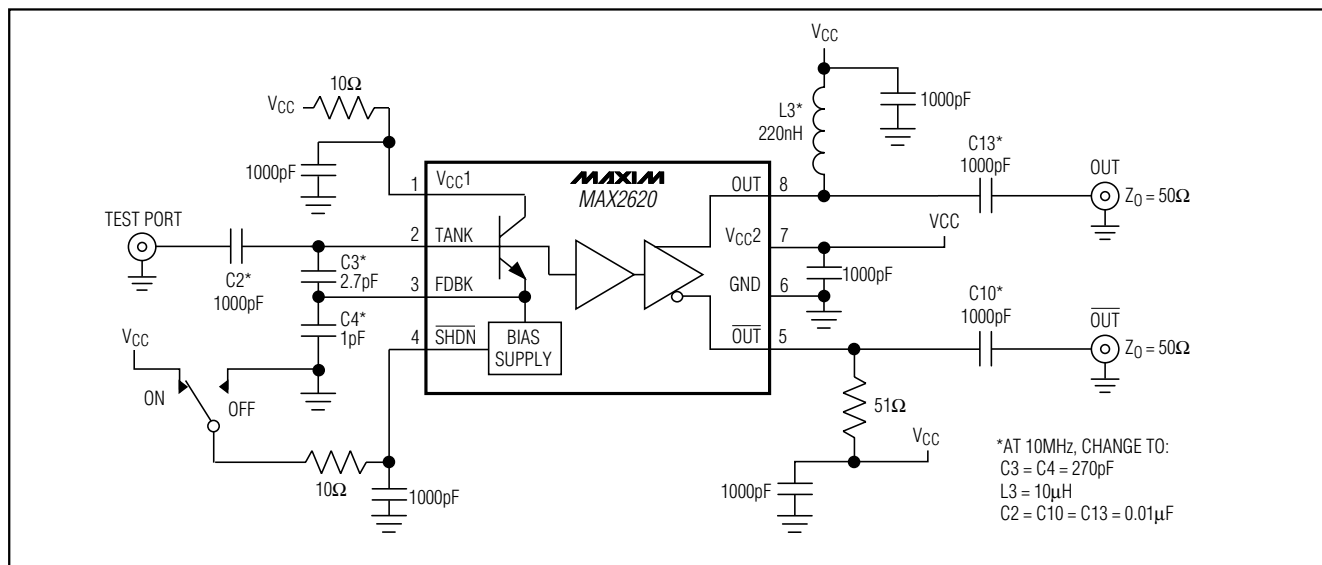

Figure 1. 900MHz Test Circuit

Detailed Description

Oscillator

The oscillator is a common-collector, negative-resistance type that uses the IC's internal parasitic elements to create a negative resistance at the base-emitter port. The transistor oscillator has been optimized for low-noise operation. Base and emitter leads are provided as external connections for a feedback capacitor and resonator. A resonant circuit, tuned to the appropriate frequency and connected to the base lead, will cause oscillation. Varactor diodes may be used in the resonant circuit to create a voltage-controlled oscillator (VCO). The oscillator is internally biased to an optimal operating point, and the base and emitter leads need to be capacitively coupled due to the bias voltages present.

Output Buffers

The output buffers (OUT and $\overline{\text{OUT}}$) are an open-collector, differential-pair configuration and provide load isolation to the oscillator. The outputs can be used differentially to drive an integrated circuit mixer. Alternatively, isolation is provided between the buffer outputs when one output drives a mixer (either up-conversion or down-conversion) and the other output drives a prescaler. The isolation in this configuration prevents prescaler noise from corrupting the oscillator signal's spectral purity.

A logic-controlled $\overline{\text{SHDN}}$ pin turns off all bias to the IC when pulled low.

Applications Information

Design Principles

At the frequency of interest, the MAX2620 portion of Figure 2 shows the one-port circuit model for the TANK pin (test port in Figure 1).

For the circuit to oscillate at a desired frequency, the resonant tank circuit connected to TANK must present an impedance that is a complement to the network (Figure 2). This resonant tank circuit must have a positive real component that is a maximum of one-half the magnitude of the negative real part of the oscillator device, as well as a reactive component that is opposite in sign to the reactive component of the oscillator device.

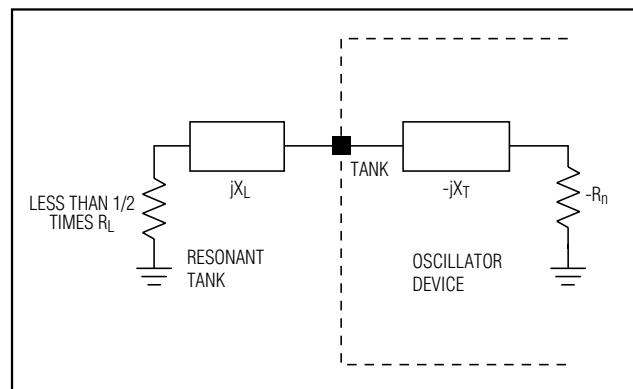

Figure 2. Simplified Oscillator Circuit Model

10MHz to 1050MHz Integrated RF Oscillator with Buffered Outputs

Keeping the resonant tank circuit's real component less than one-half the magnitude of the negative real component ensures that oscillations will start. After start-up, the oscillator's negative resistance decreases, primarily due to gain compression, and reaches equilibrium with the real component (the circuit losses) in the resonant tank circuit. Making the resonant tank circuit reactance tunable (e.g., through use of a varactor diode) allows for tuneability of the oscillation frequency, as long as the oscillator exhibits negative resistance over the desired tuning range. See Figures 3 and 4.

The negative resistance of the MAX2620 TANK pin can be optimized at the desired oscillator frequency by proper selection of feedback capacitors C3 and C4. For example, the one-port characteristics of the device are given as a plot of $1/S_{11}$ in the *Typical Operating Characteristics*. $1/S_{11}$ is used because it maps inside the unit circle Smith chart when the device exhibits negative resistance (reflection gain).

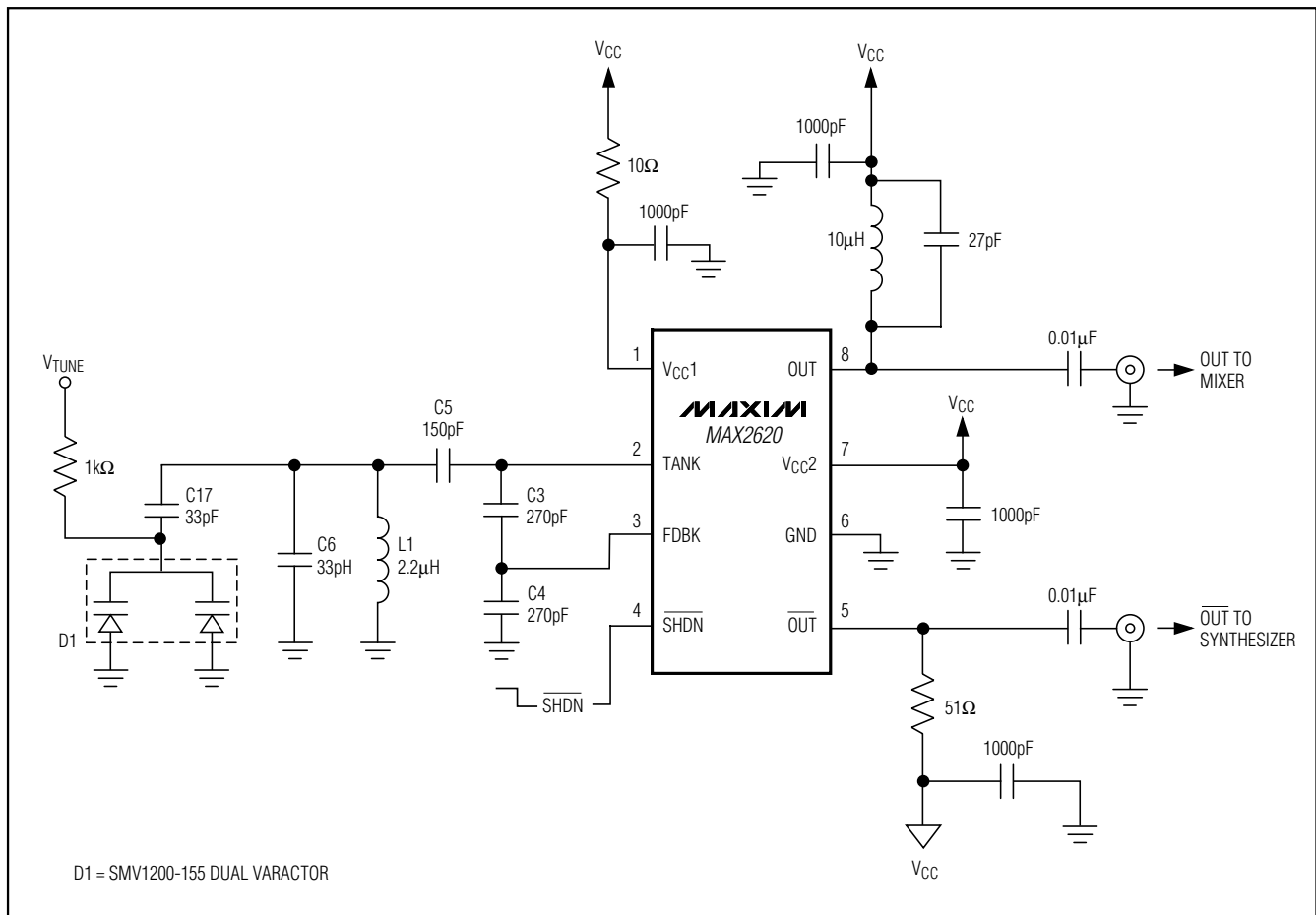

Figure 3. 10MHz VCO LC Resonator

10MHz to 1050MHz Integrated RF Oscillator with Buffered Outputs

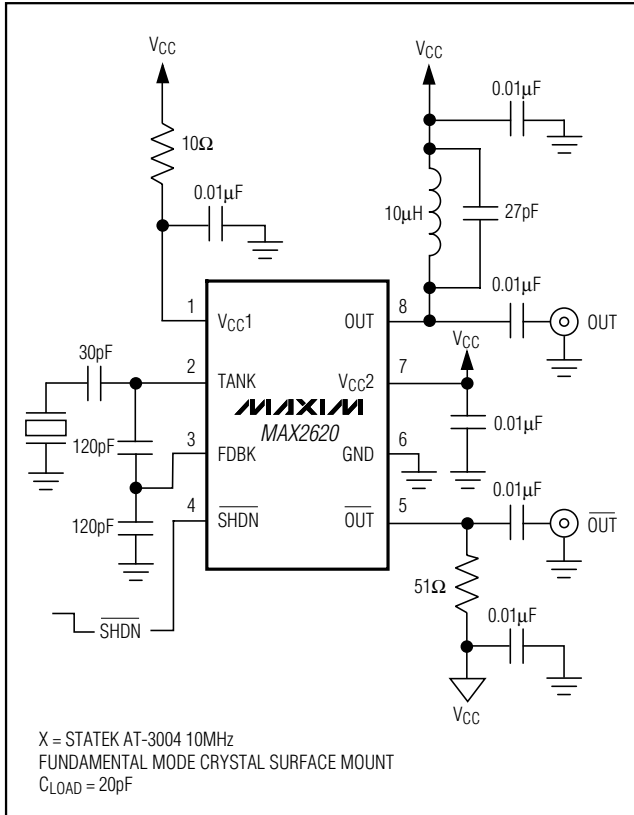

Figure 4. 10MHz Crystal Oscillator

Sample Calculation

According to the electrical model shown in Figure 5, the resonance frequency can be calculated as:

[Equation 1]

$$f_0 = \frac{1}{2\pi \sqrt{L1 \left[C_{STRAY} + \frac{C_{17} \times C_{D1}}{C_{17} + C_{D1}} + C_6 + \frac{C_5 \times C_n}{C_5 + C_n} \right]}}$$

$$\text{where } C_n = \frac{(C_3 + C_{03})(C_4 + C_{04})}{C_3 + C_{03} + C_4 + C_{04}}$$

R_n , the negative real impedance, is set by C_3 and C_4 and is approximately:

[Equation 2]

$$R_n = g_m \left(\frac{1}{2\pi f (C_3 + C_{03})} \right) \left(\frac{1}{2\pi f (C_4 + C_{04})} \right)$$

where $g_m = 18\text{mS}$.

Using the circuit model of Figure 5, the following example describes the design of an oscillator centered at 900MHz.

Choose: $L1 = 5\text{nH} \pm 10\%$

$Q = 140$

Calculate: $R_p = Q \times 2\pi \times f \times L1$

Using Equation 1, solve for varactor capacitance (C_{D1}). C_{D1} is the capacitance of the varactor when the voltage applied to the varactor is approximately at half-supply (the center of the varactor's capacitance range). Assume the following values:

$C_{STRAY} = 2.7\text{pF}$, $C_{17} = 1.5\text{pF}$, $C_6 = 1.5\text{pF}$, $C_5 = 1.5\text{pF}$, $C_{03} = 2.4\text{pF}$, $C_{04} = 2.4\text{pF}$, $C_3 = 2.7\text{pF}$, and $C_4 = 1\text{pF}$

The value of C_{STRAY} is based on approximate performance of the MAX2620 EV kit. Values of C_3 and C_4 are chosen to minimize R_n (Equation 2) while not loading the resonant circuit with excessive capacitance. C_{03} and C_{04} are parasitic capacitors.

The varactor's capacitance range should allow for the desired tuning range. Across the tuning frequency range, ensure that $R_s < 1/2 |R_n|$.

The MAX2620's oscillator is optimized for low-phase-noise operation. Achieving lowest phase-noise characteristics requires the use of high-Q (quality factor) components such as ceramic transmission-line type

10MHz to 1050MHz Integrated RF Oscillator with Buffered Outputs

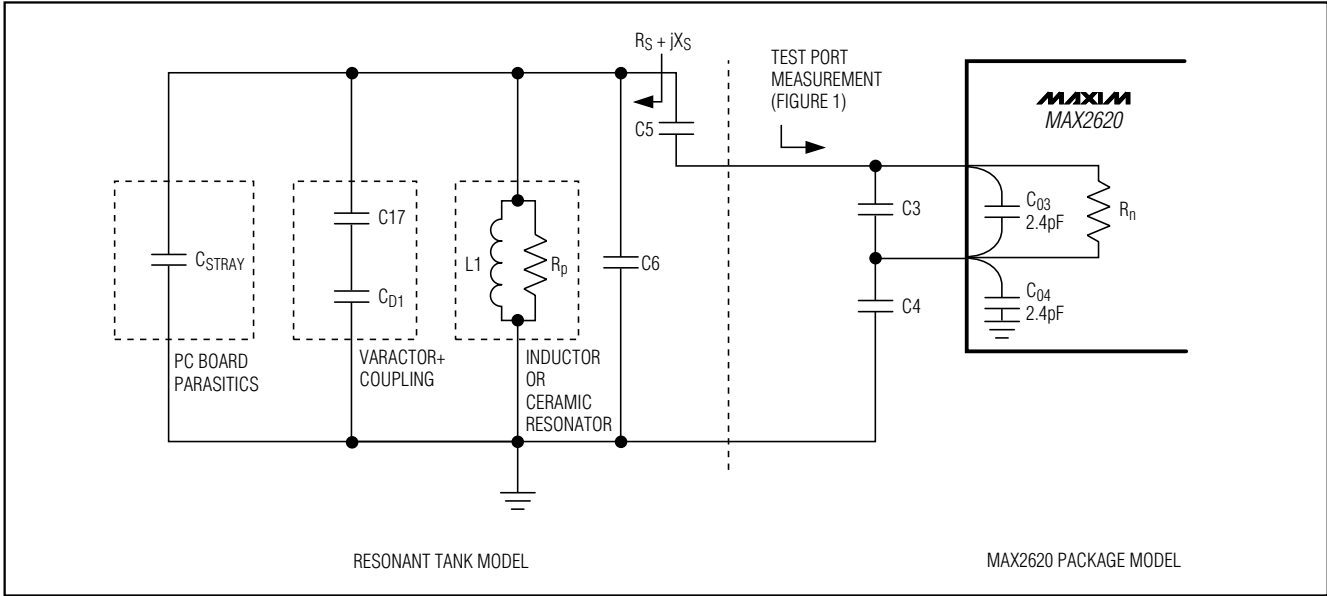

Figure 5. Electrical Model of MAX2620 Circuit

resonators or high-Q inductors. Also, keep C5 and C17 (see the *Typical Operating Circuit*) as small a value as possible while still maintaining desired frequency and tuning range to maximize loaded Q.

There are many good references on the topic of oscillator design. An excellent reference is “The Oscillator as a Reflection Amplifier, an Intuitive Approach to Oscillator Design,” by John W. Boyles, *Microwave Journal*, June 1986, pp. 83–98.

Output Matching Configuration

Both of the MAX2620’s outputs (OUT and $\overline{\text{OUT}}$) are open collectors. They need to be pulled up to the supply by external components. An easy approach to this pull-up is a resistor. A 50Ω resistor value would inherently match the output to a 50Ω system. The *Typical Operating Circuit* shows $\overline{\text{OUT}}$ configured this way. Alternatively, a choke pullup (Figure 1), yields greater output power (approximately -8dBm at 900MHz).

When maximum power is required, use an inductor as the supply pull-up, and match the inductor’s output impedance to the desired system impedance. Table 1 in the *Typical Operating Characteristics* shows recommended load impedance presented to OUT and $\overline{\text{OUT}}$

Pin Configuration

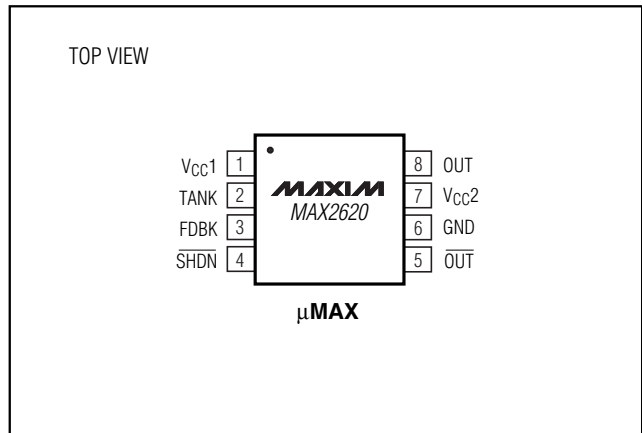

for maximum power transfer. Using this data and standard matching-network synthesis techniques, a matching network can be constructed that will optimize power output into most load impedances. The value of the inductor used for pullup should be used in the synthesis of the matching network.

10MHz to 1050MHz Integrated RF Oscillator with Buffered Outputs

Package Information

(The package drawing(s) in this data sheet may not reflect the most current specifications. For the latest package outline information, go to www.maxim-ic.com/packages.)

MAX2620

8LUMAXDLEPS

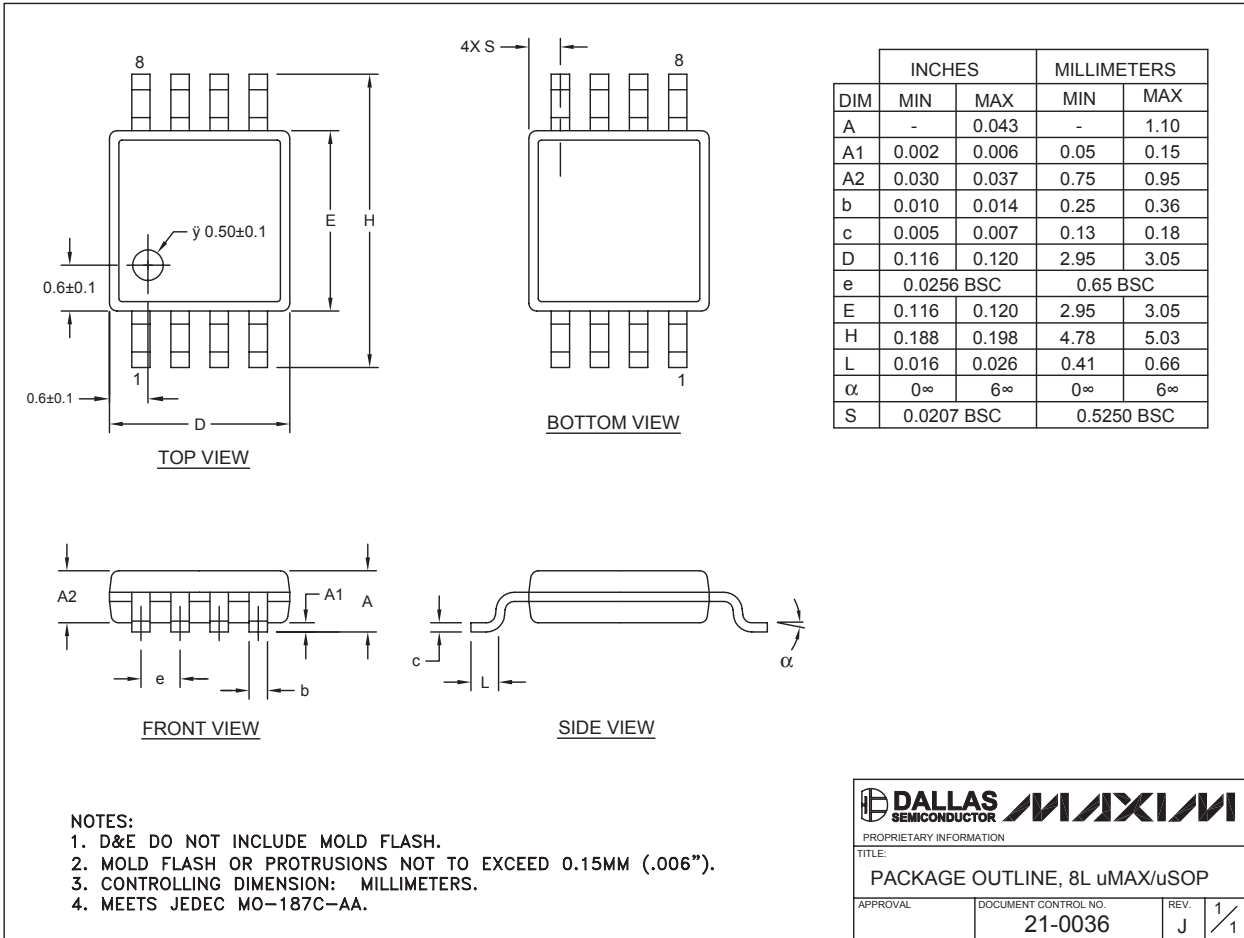

Maxim cannot assume responsibility for use of any circuitry other than circuitry entirely embodied in a Maxim product. No circuit patent licenses are implied. Maxim reserves the right to change the circuitry and specifications without notice at any time.

Maxim Integrated Products, 120 San Gabriel Drive, Sunnyvale, CA 94086 408-737-7600 11

Looking for pricing, stock, or lifecycle information?

Click below to explore more details on WIN SOURCE:

⊖ View [MAX2620EUA](#) on WIN SOURCE

⊖ [Maxim Integrated](#) Information

Optimize Your Supply Chain with WIN SOURCE Solutions

- ✓ Global Sourcing Solution
- ✓ Obsolete Management
- ✓ Cost Control Management
- ✓ Shortage Management
- ✓ Alternative Solution
- ✓ Excess Inventory Management