

Quadruple-Mode PCS/Cellular/GPS LNA/Mixers

General Description

The MAX2351/MAX2354/MAX2358/MAX2359/MAX2530/MAX2531/MAX2537/MAX2538 family of single- and multi-band LNA/mixer ICs is optimized for CDMA, GSM, and TDMA applications in both cellular and PCS bands. In addition, the MAX2530/MAX2531/MAX2537/MAX2538 ICs feature a GPS LNA/mixer signal path for E911 and traveler assistance applications. The cellular and PCS signals can be routed to either IF port. For example, one IF port can be connected to an IF filter with 30kHz bandwidth, while the other port can drive an IF filter with a wider bandwidth. The GPS band has its own IF port.

To optimize dynamic range at minimum current, the MAX2351/MAX2354/MAX2358/MAX2359/MAX2530/MAX2531/MAX2537/MAX2538 implement multiple LNA and mixer states, including high gain/high linearity, high gain/low linearity, midgain, low gain, and ultra-low gain. In high-gain/high-linearity mode, the high-IP3 LNA minimizes desensitization in the presence of a large interfering signal. For the other gain states, the LNA current is reduced to improve standby time. Each band is implemented with a separate mixer to optimize performance for the specific band, and each mixer provides multiple linearity modes to optimize linearity and current consumption. The ultra-low gain mode operates with very little current, which results in significant power savings because the handset typically spends most of its time in this mode.

Applications

Triple-Band, Quadruple-Mode PCS/Cellular Handsets
Single-Band Handsets
E911 and Traveler Assistance Through GPS
GSM/TDMA Cellular Phones

Selector Guide

PART	CELL	PCS	GPS	CELL VCO	PCS VCO
MAX2351	✓	✓	—	Input	Internal doubler
MAX2354	✓	—	—	Input	—
MAX2358	✓	✓	—	Internal divider	Input
MAX2359	—	✓	—	—	Input
MAX2530	✓	✓	✓	Input	Input
MAX2531	✓	✓	✓	Input	Internal doubler
MAX2537	✓	—	✓	Internal divider	Input
MAX2538	✓	✓	✓	Internal divider	Input

Features

- ◆ Eliminate Up to 35 External Components
- ◆ Low LNA Noise Figure
 - PCS: 1.2dB
 - Cellular: 0.9dB
 - GPS: 1.0dB
- ◆ No External GPS VCO Required
- ◆ No Interstage GPS SAW Filter Required
- ◆ Triple Band, Quadruple Mode
- ◆ Ultra-Low Current: <10mA Average in CDMA Phones
- ◆ Small 28-Pin QFN Package (5mm × 5mm)

Ordering Information

PART	TEMP RANGE	PIN-PACKAGE
MAX2351ETI	-40°C to +85°C	28 Thin QFN-EP*
MAX2354ETI	-40°C to +85°C	28 Thin QFN-EP*
MAX2358ETI	-40°C to +85°C	28 Thin QFN-EP*
MAX2359ETI	-40°C to +85°C	28 Thin QFN-EP*
MAX2530ETI	-40°C to +85°C	28 Thin QFN-EP*
MAX2531ETI	-40°C to +85°C	28 Thin QFN-EP*
MAX2537ETI	-40°C to +85°C	28 Thin QFN-EP*
MAX2538ETI	-40°C to +85°C	28 Thin QFN-EP*

*EP = exposed pad.

Pin Configurations

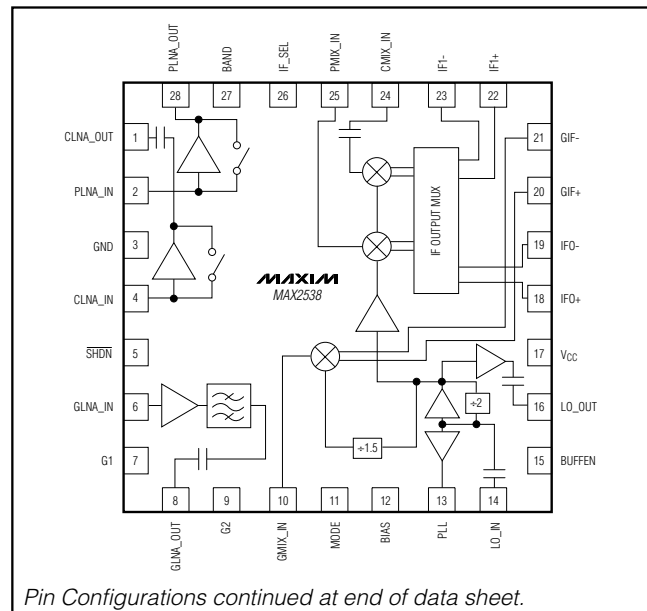

Pin Configurations continued at end of data sheet.

Quadruple-Mode PCS/Cellular/GPS LNA/Mixers

ABSOLUTE MAXIMUM RATINGS

V _{CC} to GND	-0.3V to +4.3V
Digital Input Voltage to GND	-0.3V to (V _{CC} + 0.3V)
LNA Input (Low-Gain Mode) Level	15dBm
LO Input Level	5dBm
Digital Input Current	10mA
Continuous Power Dissipation (T _A = +70°C)	
28-Pin QFN-EP (derate 21mW/°C	
above +70°C)	1.6W

Operating Temperature Range	-40°C to +85°C
Junction Temperature	+150°C
Storage Temperature Range	-65°C to +150°C
Lead Temperature (soldering 10s)	+300°C

Stresses beyond those listed under "Absolute Maximum Ratings" may cause permanent damage to the device. These are stress ratings only, and functional operation of the device at these or any other conditions beyond those indicated in the operational sections of the specifications is not implied. Exposure to absolute maximum rating conditions for extended periods may affect device reliability.

DC ELECTRICAL CHARACTERISTICS

(V_{CC} = 2.7V to 3.3V, R_{BIAS} = 20kΩ, T_A = -40°C to +85°C. Typical values are at V_{CC} = 2.75V and T_A = +25°C, unless otherwise noted.) (Note 1)

PARAMETER	CONDITIONS		MIN	TYP	MAX	UNITS
PCS MODE (see Table 1 for abbreviations)						
Operating Supply Current	ULG	MAX2358/MAX2359/MAX2530/MAX2538		7.4	9.0	mA
		MAX2351/MAX2531		8.1	10	
	LG	MAX2358/MAX2359/MAX2530/MAX2538		8.6	11	
		MAX2351/MAX2531		9.3	11.5	
	HGHL	MAX2358/MAX2359/MAX2530/MAX2538		26.5	32	
		MAX2351/MAX2531		27.2	33	
CELLULAR MODE (see Table 1 for abbreviations)						
Operating Supply Current	ULG	MAX2351/MAX2354/MAX2530/MAX2531		6.5	8.5	mA
		MAX2358/MAX2537/MAX2538		7.7	9.5	
	LG	MAX2351/MAX2354/MAX2530/MAX2531		13.9	17	
		MAX2358/MAX2537/MAX2538		15.1	18.5	
	MG	MAX2354/MAX2530		23.5	28	
		MAX2351/MAX2531		21.5	26	
		MAX2358/MAX2537/MAX2538		24.7	29.5	
	HGLL	MAX2351/MAX2354/MAX2530/MAX2531		20.6	26	
		MAX2358/MAX2537/MAX2538		21.8	27.5	
	HGHL	MAX2354/MAX2530		27.7	35	
		MAX2351/MAX2531		25.7	33.5	
		MAX2358/MAX2537/MAX2538		28.9	36	
GPS MODE (MAX2530/MAX2531/MAX2538)						
Operating Supply Current	PLL = low	MAX2530/MAX2537/MAX2538		18.9	23	mA
		MAX2531		19.6	24	
SHUTDOWN MODE						
Shutdown Supply Current	$\overline{\text{SHDN}}$ = low, BUFFEN = PLL = low				20	μA
ALL MODES						
Digital Input Logic High			1.8			V
Digital Input Logic Low					0.6	V

Quadruple-Mode PCS/Cellular/GPS LNA/Mixers

MAX2351/4/8/9/MAX2530/1/7/8

DC ELECTRICAL CHARACTERISTICS (continued)

($V_{CC} = 2.7V$ to $3.3V$, $R_{BIAS} = 20k\Omega$, $T_A = -40^\circ C$ to $+85^\circ C$. Typical values are at $V_{CC} = 2.75V$ and $T_A = +25^\circ C$, unless otherwise noted.) (Note 1)

PARAMETER		CONDITIONS	MIN	TYP	MAX	UNITS
Digital Input Current		Measured at guaranteed logic threshold	-10		+10	μA
Additional Current for LO_OUT Buffer		BUFFEN = high, cellular and PCS modes, $P_{LO} = -7dBm$		2.4	3.5	mA
Buffer-Only Mode Supply Mode	\overline{SHDN} = low, BUFFEN = high, $P_{LO} = -7dBm$	PCS MAX2358/MAX2359/MAX2530/MAX2538		5.4	7	mA
		PCS MAX2351/MAX2531		6.1	7.5	
		CELL MAX2351/MAX2354/MAX2530/MAX2531		4.7	6.5	
		CELL MAX2358/MAX2537/MAX2538		5.9	7.5	
PLL-Only Mode	\overline{SHDN} = low, PLL = high, $P_{LO} = -7dBm$		3.2	4.5	mA	

AC ELECTRICAL CHARACTERISTICS

(EV kits to evaluate the MAX2351/MAX2354/MAX2358/MAX2359/MAX2530/MAX2531/MAX2357/MAX2538, $f_{CELL} = 869MHz$ to $894MHz$, $f_{PCS} = 1930MHz$ to $1990MHz$, $f_{GPS} = 1575.42MHz$ (MAX2530/MAX2531/MAX2537/MAX2538), $f_{IF} = 183.6MHz$, high-side LO for all except GPS, 50Ω system impedance, $V_{CC} = 2.7V$ to $3.3V$, $R_{BIAS} = 20k\Omega$, $R_{IF0} = R_{IF1} = 3.3k\Omega$, $R_{GIF} = 8.2k\Omega$, LO input power = $-10dBm$, $T_A = -40^\circ C$ to $+85^\circ C$. Typical values are at $f_{CELL} = 881MHz$, $f_{PCS} = 1960MHz$, $V_{CC} = 2.75V$, LO input power = $-7dBm$, unless otherwise noted.) (Note 2)

PARAMETER		CONDITIONS	MIN	TYP	MAX	UNITS	
OVERALL PERFORMANCE							
IF Frequency Range		IF0 and IF1 (Note 3)	70	183.6	400	MHz	
GPS IF Frequency Range		GIF (Note 3)	110	183.6	225	MHz	
Cellular RF Frequency Range		(Note 1)	869		894	MHz	
PCS RF Frequency Range		(Note 1)	1930		1990	MHz	
LO Leakage to LNA inputs					-40	dBm	
LO Output Power		Cell, BUFFEN = high, 50Ω load, LO input power = $-10dBm$ (Note 1)	-10	-5		dBm	
		PCS, BUFFEN = high, 50Ω load, LO input power = $-10dBm$ (Note 1)	-11	-7			
PLL Output Power			-12			dBm	
LNA PERFORMANCE (see Table 1 for abbreviations)							
LNA Gain (Note 1)	CELL	HGHL	$T_A = +25^\circ C$	13.8	15	16.0	dB
			$T_A = -40^\circ C$ to $+85^\circ C$	13.3		16.5	
		HGLL	$T_A = +25^\circ C$	13.5	14.5	15.5	
			$T_A = -40^\circ C$ to $+85^\circ C$	13.0		16.0	
		MG	$T_A = +25^\circ C$	1.0	1.9	3.0	
			$T_A = -40^\circ C$ to $+85^\circ C$	0.5		3.0	
		LG/ULG	$T_A = +25^\circ C$	-6	-4.9	-4	
			$T_A = -40^\circ C$ to $+85^\circ C$	-6.5		-3.5	

Quadruple-Mode PCS/Cellular/GPS LNA/Mixers

MAX2351/4/8/9/MAX2530/1/7/8

AC ELECTRICAL CHARACTERISTICS (continued)

(EV kits to evaluate the MAX2351/MAX2354/MAX2358/MAX2359/MAX2530/MAX2531/MAX2357/MAX2538, $f_{CELL} = 869\text{MHz}$ to 894MHz , $f_{PCS} = 1930\text{MHz}$ to 1990MHz , $f_{GPS} = 1575.42\text{MHz}$ (MAX2530/MAX2531/MAX2537/MAX2538), $f_{IF} = 183.6\text{MHz}$, high-side LO for all except GPS, 50Ω system impedance, $V_{CC} = 2.7\text{V}$ to 3.3V , $R_{BIAS} = 20\text{k}\Omega$, $R_{IF0} = R_{IF1} = 3.3\text{k}\Omega$, $R_{GIF} = 8.2\text{k}\Omega$, LO input power = -10dBm , $T_A = -40^\circ\text{C}$ to $+85^\circ\text{C}$. Typical values are at $f_{CELL} = 881\text{MHz}$, $f_{PCS} = 1960\text{MHz}$, $V_{CC} = 2.75\text{V}$, LO input power = -7dBm , unless otherwise noted.) (Note 2)

PARAMETER	CONDITIONS		MIN	TYP	MAX	UNITS	
LNA Gain (Note 1)	PCS	HGHL	$T_A = +25^\circ\text{C}$	15	16	17	dB
			$T_A = -40^\circ\text{C}$ to $+85^\circ\text{C}$	14.5		17.5	
	LG/ULG	$T_A = +25^\circ\text{C}$	-5.5	-4.5	-3.2		
		$T_A = -40^\circ\text{C}$ to $+85^\circ\text{C}$	-6	-4.5	-3.2		
	GPS	$T_A = +25^\circ\text{C}$	16	17.7	19		
		$T_A = -40^\circ\text{C}$ to $+85^\circ\text{C}$	15.5		20		
LNA Noise Figure	CELL	HGHL/ HGLL	$T_A = +25^\circ\text{C}$		0.9	1.2	dB
			Change over temperature from $T_A = +25^\circ\text{C}$ to $+85^\circ\text{C}$		0.2		
		MG	$T_A = +25^\circ\text{C}$		2.0	2.5	
		LG/ULG	$T_A = +25^\circ\text{C}$		5.0	6.5	
	PCS	HGHL	$T_A = +25^\circ\text{C}$		1.2	1.5	
			Change over temperature from $T_A = +25^\circ\text{C}$ to $+85^\circ\text{C}$		0.2		
		LG/ULG	$T_A = +25^\circ\text{C}$		5.5	7.0	
	GPS	$T_A = +25^\circ\text{C}$		1.0	1.3		
		Change over temperature from $T_A = +25^\circ\text{C}$ to $+85^\circ\text{C}$		0.2			
	LNA IP3 (Note 4)	CELL	HGHL	$P_{IN} = -25\text{dBm}$, $T_A = -40^\circ\text{C}$ to $+85^\circ\text{C}$ (Note 1)	9.5	13	
HGLL			$P_{IN} = -25\text{dBm}$, $T_A = -40^\circ\text{C}$ to $+85^\circ\text{C}$	6.5	12.2		
MG			$P_{IN} = -25\text{dBm}$, $T_A = -40^\circ\text{C}$ to $+85^\circ\text{C}$	13.5	17		
LG/ULG			$P_{IN} = -15\text{dBm}$, $T_A = -40^\circ\text{C}$ to $+85^\circ\text{C}$	20	24.6		
PCS		HGHL	$P_{IN} = -25\text{dBm}$, $T_A = -40^\circ\text{C}$ to $+85^\circ\text{C}$ (Note 1)	8	12		
		LG/ULG	$P_{IN} = -15\text{dBm}$, $T_A = -40^\circ\text{C}$ to $+85^\circ\text{C}$	20	24.4		
GPS		$P_{IN} = -25\text{dBm}$, $T_A = -40^\circ\text{C}$ to $+85^\circ\text{C}$	0	4.6			

Quadruple-Mode PCS/Cellular/GPS LNA/Mixers

AC ELECTRICAL CHARACTERISTICS (continued)

(EV kits to evaluate the MAX2351/MAX2354/MAX2358/MAX2359/MAX2530/MAX2531/MAX2357/MAX2538, $f_{CELL} = 869\text{MHz}$ to 894MHz , $f_{PCS} = 1930\text{MHz}$ to 1990MHz , $f_{GPS} = 1575.42\text{MHz}$ (MAX2530/MAX2531/MAX2537/MAX2538), $f_{IF} = 183.6\text{MHz}$, high-side LO for all except GPS, 50Ω system impedance, $V_{CC} = 2.7\text{V}$ to 3.3V , $R_{BIAS} = 20\text{k}\Omega$, $R_{IF0} = R_{IF1} = 3.3\text{k}\Omega$, $R_{GIF} = 8.2\text{k}\Omega$, LO input power = -10dBm , $T_A = -40^\circ\text{C}$ to $+85^\circ\text{C}$. Typical values are at $f_{CELL} = 881\text{MHz}$, $f_{PCS} = 1960\text{MHz}$, $V_{CC} = 2.75\text{V}$, LO input power = -7dBm , unless otherwise noted.) (Note 2)

PARAMETER	CONDITIONS		MIN	TYP	MAX	UNITS	
MIXER PERFORMANCE (see Tables 1 and 2 for abbreviations)							
Mixer Gain (Note 1)	CELL	HGHL/ MG	$T_A = +25^\circ\text{C}$	9.5	12.5	15.0	dB
			$T_A = -40^\circ\text{C}$ to $+85^\circ\text{C}$	8.5		16	
		HGLL/ LG	$T_A = +25^\circ\text{C}$	9.0	12	14.5	
			$T_A = -40^\circ\text{C}$ to $+85^\circ\text{C}$	8		15.5	
		ULG	$T_A = +25^\circ\text{C}$	6	10	12.5	
			$T_A = -40^\circ\text{C}$ to $+85^\circ\text{C}$	5		14	
	PCS	HGHL	$T_A = +25^\circ\text{C}$	10.0	13	16.5	
			$T_A = -40^\circ\text{C}$ to $+85^\circ\text{C}$	8.5		16.5	
		LG	$T_A = +25^\circ\text{C}$	8.0	12	14.5	
			$T_A = -40^\circ\text{C}$ to $+85^\circ\text{C}$	6.5	12	14.5	
		ULG	$T_A = +25^\circ\text{C}$	7.5	11	13.5	
			$T_A = -40^\circ\text{C}$ to $+85^\circ\text{C}$	6.0		14.5	
GPS	$T_A = +25^\circ\text{C}$	12.0	15	17.5			
	$T_A = -40^\circ\text{C}$ to $+85^\circ\text{C}$	10	13	19			
Mixer Noise Figure	CELL	HGHL/ MG	$T_A = +25^\circ\text{C}$		8	9.5	dB
			Change over temperature from $T_A = +25^\circ\text{C}$ to $+85^\circ\text{C}$		0.3		
		HGLL/ LG	$T_A = +25^\circ\text{C}$		7.2	9	
	ULG	$T_A = +25^\circ\text{C}$		7	9		
	PCS	HGHL	$T_A = +25^\circ\text{C}$		7	8.5	
			Change over temperature from $T_A = +25^\circ\text{C}$ to $+85^\circ\text{C}$		0.3		
		LG	$T_A = +25^\circ\text{C}$		6.2	7.5	
	ULG	$T_A = +25^\circ\text{C}$		6	7.5		
	GPS	$T_A = +25^\circ\text{C}$		7.2	9		
		Change over temperature from $T_A = +25^\circ\text{C}$ to $+85^\circ\text{C}$		0.5			

MAX2351/4/8/9/MAX2530/1/7/8

Quadruple-Mode PCS/Cellular/GPS LNA/Mixers

AC ELECTRICAL CHARACTERISTICS (continued)

(EV kits to evaluate the MAX2351/MAX2354/MAX2358/MAX2359/MAX2530/MAX2531/MAX2357/MAX2538, $f_{CELL} = 869\text{MHz}$ to 894MHz , $f_{PCS} = 1930\text{MHz}$ to 1990MHz , $f_{GPS} = 1575.42\text{MHz}$ (MAX2530/MAX2531/MAX2537/MAX2538), $f_{IF} = 183.6\text{MHz}$, high-side LO for all except GPS, 50Ω system impedance, $V_{CC} = 2.7\text{V}$ to 3.3V , $R_{BIAS} = 20\text{k}\Omega$, $R_{IF0} = R_{IF1} = 3.3\text{k}\Omega$, $R_{GIF} = 8.2\text{k}\Omega$, LO input power = -10dBm , $T_A = -40^\circ\text{C}$ to $+85^\circ\text{C}$. Typical values are at $f_{CELL} = 881\text{MHz}$, $f_{PCS} = 1960\text{MHz}$, $V_{CC} = 2.75\text{V}$, LO input power = -7dBm , unless otherwise noted.) (Note 2)

PARAMETER	CONDITIONS		MIN	TYP	MAX	UNITS		
Mixer IP3 (Note 4)	CELL	HGHL/ MG	MAX2354/MAX2358/MAX2530/ MAX2537/MAX2538, $P_{IN} = -20\text{dBm}$ (Note 1)	6	7.8	dBm		
			MAX2351/MAX2531, $P_{IN} = -20\text{dBm}$	4	6.5			
		HGLL/ LG	$P_{IN} = -20\text{dBm}$		3.5		6.5	
			ULG		$P_{IN} = -20\text{dBm}$		-4.5	-2.2
	PCS	HGHL	$P_{IN} = -20\text{dBm}$ (Note 1)	MAX2358/MAX2359/ MAX2530/MAX2538	3		5	
				MAX2351/MAX2531	2.5		4.5	
		LG	$P_{IN} = -20\text{dBm}$		-4.5		-1.8	
	GPS	ULG		$P_{IN} = -20\text{dBm}$			-7	-3.6
		GPS		$P_{IN} = -20\text{dBm}$			-3	0.5

Note 1: Guaranteed at $T_A = +25^\circ\text{C}$ and $T_A = +85^\circ\text{C}$ by production test, and guaranteed by design and characterization at $T_A = -40^\circ\text{C}$.

Note 2: Minimum and maximum specs are guaranteed by design and characterization, unless otherwise noted.

Note 3: Operating over this frequency range requires the ports to be rematched for the desired operating frequency.

Note 4: Two-tone separation is 900kHz cellular, 1.25MHz for PCS, and 1MHz for GPS.

Typical Operating Characteristics

(MAX2538 EV kit, $f_{IF} = 183.6\text{MHz}$, high-side LO for all modes except GPS, 50Ω system impedance, $R_{BIAS} = 20\text{k}\Omega$, $R_{IF0} = R_{IF1} = 3.3\text{k}\Omega$, $R_{GIF} = 8.2\text{k}\Omega$, $f_{CELL} = 881\text{MHz}$, $f_{PCS} = 1960\text{MHz}$, $f_{GPS} = 1575.42\text{MHz}$, $V_{CC} = 2.75\text{V}$, LO input power = -7dBm , HGHL mode, $T_A = +25^\circ\text{C}$, unless otherwise noted.)

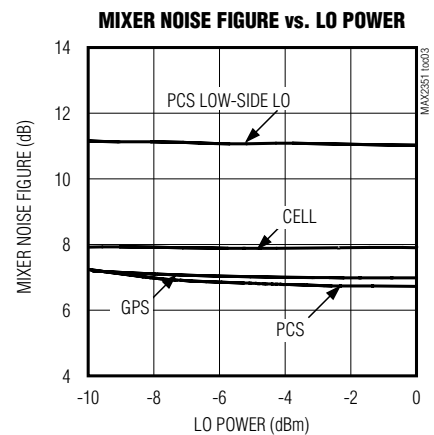
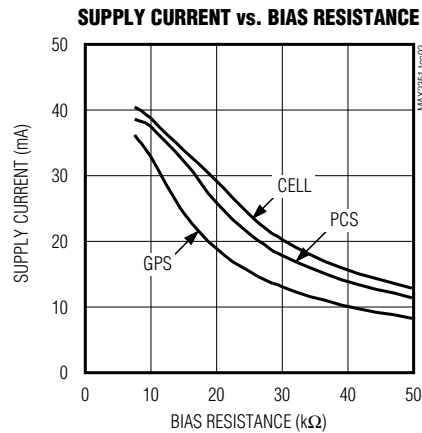
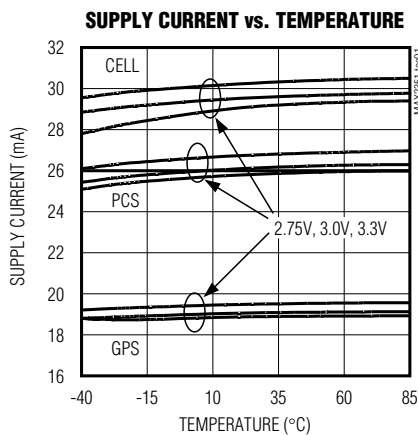

Quadruple-Mode PCS/Cellular/GPS LNA/Mixers

Typical Operating Characteristics (continued)

(MAX2538 EV kit, $f_{IF} = 183.6\text{MHz}$, high-side LO for all modes except GPS, 50Ω system impedance, $R_{BIAS} = 20\text{k}\Omega$, $R_{IF0} = R_{IF1} = 3.3\text{k}\Omega$, $R_{GIF} = 8.2\text{k}\Omega$, $f_{CELL} = 881\text{MHz}$, $f_{PCS} = 1960\text{MHz}$, $f_{GPS} = 1575.42\text{MHz}$, $V_{CC} = 2.75\text{V}$, LO input power = -7dBm , HGHL mode, $T_A = +25^\circ\text{C}$, unless otherwise noted.)

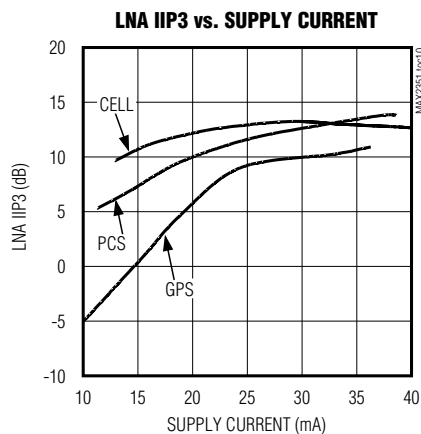
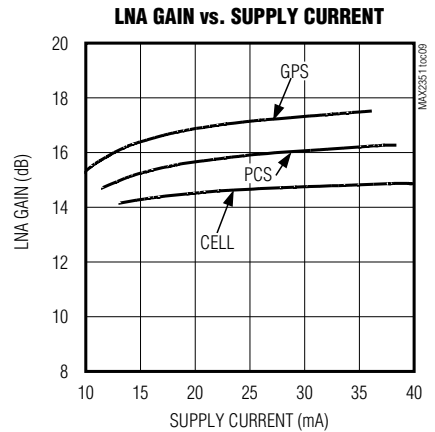
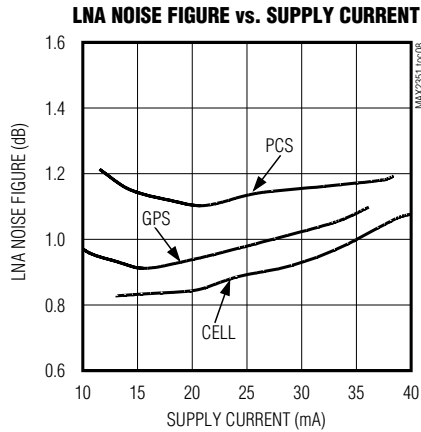
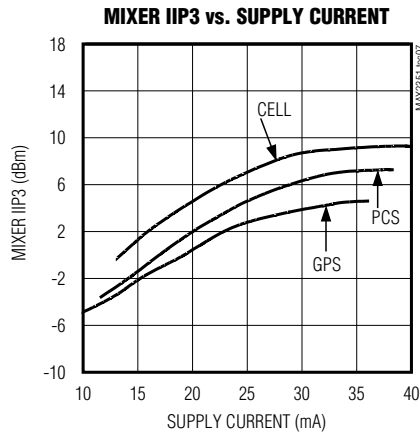
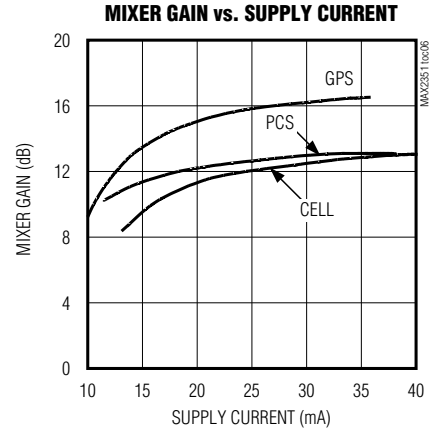
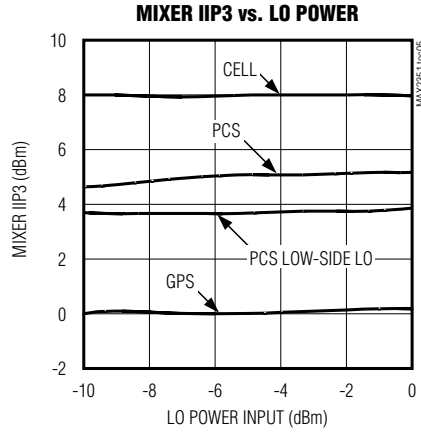
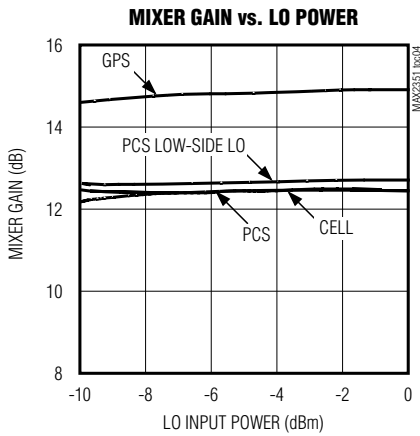

MAX2351/4/8/9/MAX2530/1/7/8

Quadruple-Mode PCS/Cellular/GPS LNA/Mixers

Pin Description

PIN					NAME	FUNCTION
MAX2351 MAX2358	MAX2354	MAX2359	MAX2530 MAX2531 MAX2538	MAX2537		
1	1	—	1	1	CLNA_OUT	Cellular LNA Output. Internally matched to 50Ω including an on-chip DC-blocking capacitor.
2	—	2	2	—	PLNA_IN	PCS LNA Input. Requires a DC-blocking capacitor that can be used as part of the matching network.
3	3, 27	3	3	3	GND	Ground
4	4	—	4	4	CLNA_IN	Cellular LNA Input. Requires a DC-blocking capacitor that can be used as part of the matching network.
5	5	5	5	5	$\overline{\text{SHDN}}$	Shutdown Logic Input. A logic low shuts off the device, except LO_OUT and PLL buffers, which are controlled by BUFFEN and PLL pins, respectively.
6, 8	2, 6, 8	1, 4, 6, 8, 24	—	2	N.C./GND	Pin can be grounded or left open-circuit.
—	—	—	6	6	GLNA_IN	GPS LNA Input. Requires a DC-blocking capacitor, which can be used as part of the matching network.
7	7	7	7	7	G1	Operating Mode Logic Input. Sets device operating modes. See Table 2 for details.
—	—	—	8	8	GLNA_OUT	GPS LNA Output. Internally matched to 50Ω including an on-chip DC-blocking capacitor.
9	9	9	9	9	G2	Operating Mode Logic Input. Sets device operating modes. See Table 2 for details.
10, 20, 21	10, 20, 21, 25, 28	10, 20, 21, 27	—	25, 28	I.C.	Internally Connected. Do not make connections to this pin.
—	—	—	10	10	GMIX_IN	GPS Mixer Input. Requires a DC-blocking capacitor, which can be used as an interstage coupling capacitor.
11	11	11	11	11	MODE	Operating Mode Logic Input. Sets device operating modes. See Table 2 for details.
12	12	12	12	12	BIAS	Bias Setting Pin. For nominal bias, connect a 20kΩ resistor to ground. Adjust R _{BIAS} to alter the linearity of the mixers and LNAs.
13	13	13	13	13	PLL	Dual-Function Pin. LO buffer output port for driving an external PLL synthesizer. A logic high (through a 10kΩ resistor) enables the PLL buffer. A logic low disables the PLL buffer. Leave open if not used. If open, PLL is low.
14	14	14	14	14	LO_IN	LO Input. Internally matched to 50Ω, including DC-blocking capacitor.
15	15	15	15	15	BUFFEN	LO Buffer Enable Logic Input. A logic high enables the external LO buffer port. Floats low.

Quadruple-Mode PCS/Cellular/GPS LNA/Mixers

Pin Description (continued)

MAX2351/4/8/9/MAX2530/1/7/8

PIN					NAME	FUNCTION
MAX2351 MAX2358	MAX2354	MAX2359	MAX2530 MAX2531 MAX2538	MAX2537		
16	16	16	16	16	LO_OUT	PCS and Cellular LO Output. Output frequency is equal to mixer LO frequency. Internally matched with DC-blocking capacitor. If not used, connect pin to ground or leave open.
17	17	17	17	17	V _{CC}	2.7V to 3.3V Supply Pin. Connect a 100pF bypass capacitor as close as possible to the pin.
18, 19	18, 19	18, 19	18, 19	18, 19	IF0+, IF0-	Differential IF Output Port 0. Requires a pullup inductor and a DC-blocking capacitor at each pin, which can be used as part of the matching network. If not used, connect pins to V _{CC} .
—	—	—	20, 21	20, 21	GIF+, GIF-	GPS IF Output. Requires a pullup inductor and a DC-blocking capacitor at each pin, which can be used as part of the matching network. If not used, connect pins to V _{CC} .
22, 23	22, 23	22, 23	22, 23	22, 23	IF1+, IF1-	Differential IF Output Port 1. Requires a pullup inductor and a DC-blocking capacitor at each pin, which can be used as part of the matching network. If not used, connect pins to V _{CC} .
24	24	—	24	24	CMIX_IN	Cellular Mixer Input. Internally matched to 50Ω, including an on-chip DC-blocking capacitor.
25	—	25	25	—	PMIX_IN	PCS Mixer Input. Internally matched to 50Ω. Requires a DC-blocking capacitor.
26	26	26	26	26	IF_SEL	IF Select Logic Input. Logic low selects IF0 port, and logic high selects IF1 port.
27	—	—	27	27	BAND	BAND Logic Input. See Table 2 for details.
28	—	28	28	—	PLNA_OUT	PCS LNA Output. Requires a pullup inductor and a DC-blocking capacitor, which can be used as part of the matching network.
EP	EP	EP	EP	EP	Exposed	Exposed Pad. RF and DC ground.

Detailed Description

Signal Paths and Operation Modes

The MAX2351/MAX2354/MAX2358/MAX2359/MAX2530/MAX2531/MAX2537/MAX2538 have multiple RF signal paths. The cellular signal path has five modes of operation using a 4-gain-mode LNA and a 3-gain-mode mixer. Similarly, the PCS signal path has four modes of operation made up of a 2-gain-mode LNA and a 3-gain-mode mixer. The cellular and PCS mixer's IF output can be routed to either the IF0 or IF1 port. The GPS signal path consists of a single-mode GPS, LNA, and mixer, which has a dedicated IF output port. Tables 1 and 2 summarize the modes of operation.

Low-Noise Amplifiers

The MAX2351/MAX2358/MAX2530/MAX2531/MAX2538 incorporate three LNA signal paths for the cellular, PCS, and GPS bands. Using Maxim's latest advanced BiCMOS SiGe process, these LNAs deliver 1dB noise figure for cellular, PCS, and GPS bands. The cellular band LNAs have four modes of operation: high gain/high linearity (HGHL), high gain/low linearity (HGLL), midgain (MG), and low gain (LG). The PCS band LNAs have two modes of operation: high gain/high linearity and low gain. The GPS LNA has only one mode.

The BAND input selects the frequency band. The G1, G2, and MODE pins are logic inputs that control the LNA modes (see Table 2). Use HGHL mode when high

Quadruple-Mode PCS/Cellular/GPS LNA/Mixers

LNA linearity is required for cross-modulation suppression. Use HGLL mode when the transmitter is off and cross-modulation is not a concern. The LNAs are designed to minimize input VSWR when changing modes. Use low-gain mode for receiving large signals and when high sensitivity is not required. The cellular band provides an additional gain mode (MG) for improved IP3 margin in CDMA medium-level interference condition.

Downconverters

The downconverters in these devices are double-balanced mixers. The cellular and PCS mixers have three gain modes: high linearity, low linearity, and low gain. The cellular and PCS mixers can route the IF signal to either IF0 or IF1 port. IF_SEL = low routes the IF signal to IF0 port; IF_SEL = high routes the IF signal to IF1 port. The GPS mixer has only one mode, and it has a dedicated IF port (Table 2). All mixer inputs include on-chip matching networks to reduce the external component count.

LO Generation

Table 3 shows the options for the LO generation. The on-chip LO divider or multiplier allows triple-band operation with a single VCO. The MAX2351 and MAX2531 have an LO multiplier that doubles the cellular band VCO for PCS band operation. Conversely, the MAX2358, MAX2537, and MAX2538 include an LO divider that divides the PCS VCO frequency down to cellular frequency band. The GPS LO is generated by a fractional frequency scaler, which enables a single VCO for operation in all three bands. The MAX2530 is designed for operation with a dual-band VCO.

The PLL buffer output is provided for phase-locked loop operation. The PLL pin serves two functions: RF output signal for phase-locked loop operation and logic input to enable or disable this buffer. A logic high applied to this pin enables the PLL buffer; a logic low disables the buffer.

A buffered LO output is provided to drive a transmit upconverter. It is controlled by the BUFFEN input. For time-division duplex applications, the buffer is available to drive the transmitter even when the rest of the chip is shut down. The port is internally AC-coupled, so a DC-blocking capacitor is not required.

Bias Control

The bias control input (BIAS pin) controls the IC bias current. Typically, connect a 20k Ω resistor to ground for normal operation. Smaller bias resistor values increase the supply current and linearity.

Applications Information

Cascaded LNA/Mixer Performance

The LNA and mixer design optimizes cascaded performance in all gain and linearity modes. In high-gain/high-linearity mode, both the LNA and mixer have low noise figure, high gain, and high linearity. In this mode, the LNA has extra-high linearity for superior cross-modulation suppression. The high-gain/low-linearity mode is used when the transmitter is off and cross-modulation is not a concern. In the ultra-low-gain mode, the received signal is strong enough that sensitivity is not the limiting factor. This mode focuses on minimizing supply current. Tables 4, 5, 6 summarize the cascaded performance.

LNAs

The LNA inputs require external matching networks to optimize gain, linearity, noise figure, and return loss. A simple LC match is sufficient as shown in the *Typical Application Circuit*. The cellular and GPS LNA outputs are internally matched. The PCS LNA output requires an inductor pullup to VCC and a series capacitor as external matching elements. Table 7, 8, 9 show the S-parameters for each LNA. Tables 13, 14, 15 show LNA noise parameters.

Mixers

All mixer inputs are internally matched. The GPS and PCS mixer inputs require a DC-blocking capacitor; the cellular mixer does not. All IF outputs must be inductively pulled up to VCC. The inductive pullup may be used as part of the matching network. Because the differential IF output port is high impedance, a load resistor is typically used to ease the matching and establish the gain. A 3.3k Ω resistor is recommended for IF0 and IF1, and 8.2k Ω for the GIF port. The equivalent parallel RC impedance of the IF ports is typically 12.2k Ω in parallel with 0.75pF. Tables 10, 11, 12 show S-parameters for the mixer input points.

Table 1. Abbreviation for LNA and Mixer Modes

ABBREVIATION	MODE
HGHL	High gain/high linearity
HGLL	High gain/low linearity
MG	Midgain
LG	Low gain
ULG	Ultra-low gain
HL	High linearity
LL	Low linearity

Quadruple-Mode PCS/Cellular/GPS LNA/Mixers

MAX2351/4/8/9/MAX2530/1/7/8

Table 2. Modes of Operation

BAND	OPERATION MODE	LNA	MIXER	IF PORT	G2	G1	MODE	BAND
Cellular	HGHL	HGHL	HL	IF0 or IF1	0	0	1	0
	HGLL	HGLL	LL	IF0 or IF1	0	0	0	0
	MG	MG	HL	IF0 or IF1	0	1	X	0
	LG	LG	LL	IF0 or IF1	1	1	X	0
	ULG	LG	LG	IF0 or IF1	1	0	X	0
PCS	HGHL	HGHL	HL	IF0 or IF1	0	0	1	1
	LG	LG	LL	IF0 or IF1	1	1	X	1
	ULG	LG	LG	IF0 or IF1	1	0	X	1
GPS*	GPS	GPS	GPS	GIF	0	0	0	1

*MAX2530/MAX2531/MAX2537/MAX2538 only.

X = Don't care.

Table 3. LO Frequency Plan

PART	VCO FREQUENCY	CELLULAR LO FREQUENCY	PCS LO FREQUENCY	GPS LO FREQUENCY
MAX2351	Cell Band VCO	f_{VCO}	$2 \times f_{VCO}$	—
MAX2354	Cell Band VCO	f_{VCO}	—	—
MAX2358	PCS Band VCO	$0.5 \times f_{VCO}$	f_{VCO}	—
MAX2359	PCS Band VCO	—	f_{VCO}	—
MAX2530	Cell and PCS Dual-Band VCO	f_{VCO}	f_{VCO}	$(2/3) f_{VCO}$
MAX2531	Cell Band VCO	f_{VCO}	$2 \times f_{VCO}$	$(4/3) f_{VCO}$
MAX2537	PCS Band VCO	$0.5 \times f_{VCO}$	—	$(2/3) f_{VCO}$
MAX2538	PCS Band VCO	$0.5 \times f_{VCO}$	f_{VCO}	$(2/3) f_{VCO}$

GPS Interstage

The GPS LNA and mixer include on-chip resonant tanks that can be used instead of a saw filter for image suppression. These tanks are coupled by an external L-C network between pins 8 and 10 as shown in the *Typical Application Circuit*.

Layout Considerations

Keep RF signal lines as short as possible to minimize losses and radiation. Use controlled impedance on all high-frequency traces. Use high-Q (>40) components for the LNA input-matching circuit to achieve the lowest possible noise figure. At the mixer outputs, keep the differential signal lines together and of equal length to ensure signal balance. For proper operation, solder the exposed paddle evenly to the ground plane. Use abundant ground vias between RF traces to minimize undesired coupling.

Quadruple-Mode PCS/Cellular/GPS LNA/Mixers

MAX2351/4/8/9/MAX2530/1/7/8

Table 4. Typical Cascade Performance of Cellular-Band Receiver with 2.5dB Interstage Loss (RBIAS = 20kΩ)

PARAMETER	HGHL	HGLL	MG	LG	ULG
Conversion Gain (dB)	25.00	24.00	12.00	4.50	2.50
Noise Figure (dB)	1.91	1.79	9.10	14.50	14.50
Input IP3 (dBm)	-5.14	-6.21	7.75	13.59	5.44
Supply Current (mA) (MAX2351/MAX2354/MAX2530/MAX2531)	27.70	20.60	23.50	13.90	6.50
Supply Current (mA) (MAX2358/MAX2537/MAX2538)	28.90	21.80	24.70	15.10	7.70

Table 5. Typical Cascade Performance of PCS-Band Receiver with 2.5dB Interstage Loss (RBIAS = 20kΩ)

PARAMETER	HGHL	LG	ULG
Conversion Gain (dB)	26.00	4.50	4.00
Noise Figure (dB)	1.72	13.16	13.16
Input IP3 (dBm)	-8.54	+5.44	+3.46
Supply Current (mA) (MAX2358/MAX2359/MAX2530/MAX2538)	26.50	8.60	7.40
Supply Current (mA) (MAX2351/MAX2531)	27.20	9.30	8.10

Table 6. Typical Cascade Performance of GPS Band (RBIAS = 20kΩ)

PARAMETER	WITH 2.5dB INTERSTAGE SAW LOSS	WITH LC INTERSTAGE MATCH
Conversion Gain (dB)	30.50	29.09
Noise Figure (dB)	1.32	1.99
Input IP3 (dBm)	-15.05	-14.35
Supply Current (mA) (MAX2530/MAX2537/MAX2538)	18.90	18.90
Supply Current (mA) (MAX2531)	19.60	19.60
Image Suppression (dB)	25	15

Quadruple-Mode PCS/Cellular/GPS LNA/Mixers

Table 7. S-Parameters for Cellular LNA in HGHL Mode

FREQUENCY (Hz)	S11		S21		S12		S22	
	MAG	PHASE (DEG)	MAG	PHASE (DEG)	MAG	PHASE (DEG)	MAG	PHASE (DEG)
100M	835m	-15.10	554.2m	-115.6	736.4μ	121.10	995.1m	-8.043
200M	779.9m	-25.60	874.9m	-120.1	1.099m	119.60	986.1m	-16.150
300M	748.7m	-35.09	1.301	-121.0	1.65m	175.20	971.9m	-24.720
400M	729.4m	-44.95	1.883	-127.0	5.01m	197.80	949.1m	-34.160
500M	709.9m	-55.94	2.599	-137.2	11.55m	195.50	909.9m	-44.900
600M	687.1m	-68.06	3.396	-150.1	22.25m	188.20	845m	-57.540
700M	640.3m	-81.90	4.244	-166.0	37.71m	175.90	735.4m	-72.430
800M	557.8m	-96.31	4.959	-184.3	56.79m	160.40	570.6m	-89.160
810M	547.6m	-97.70	5.341	-203.5	76.06m	158.70	365.8m	-106.200
820M	537.1m	-99.06	5.358	-205.4	77.86m	157.10	344.5m	-107.800
830M	526.3m	-100.4	5.37	-207.3	79.62m	155.40	323.3m	-109.500
840M	515.2m	-101.70	5.379	-209.1	81.34m	153.70	302.2m	-111.100
850M	503.9m	-103.00	5.385	-211.0	83.03m	152.10	281.1m	-112.600
860M	492.5m	-104.20	5.386	-212.8	84.68m	150.40	260.2m	-114.200
870M	480.8m	-105.40	5.385	-214.6	86.29m	148.70	239.5m	-115.700
880M	469.1m	-106.50	5.38	-216.4	87.85m	147.10	218.9m	-117.200
890M	457.2m	-107.60	5.372	-218.1	89.38m	145.40	198.6m	-118.700
900M	445.3m	-108.60	5.362	-219.9	90.86m	143.70	178.6m	-120.100
1G	330.5m	-115.10	5.348	-221.6	92.3m	128.00	158.9m	-121.500
1.25G	207.7m	-94.89	4.556	-256.9	116m	97.48	216.9m	27.620
1.5G	283.4m	-86.74	3.71	-281.6	129.9m	76.60	412.3m	9.951
1.75G	382.4m	-99.91	3.071	-301.6	135.2m	60.00	529.5m	-2.140
2G	492m	-120.90	2.536	-320.9	132.1m	44.58	628.6m	-12.040
2.25G	629.8m	-149.50	1.933	-342.4	110m	29.61	739.7m	-22.720
2.5G	762.5m	-190.70	989.2m	-364.5	49.89m	50.28	853.3m	-38.460
2.75G	703.3m	-242.40	549.2m	-289.0	128.9m	89.36	833.5m	-58.420
3G	490m	-287.30	1.273	-295.0	198.4m	69.98	707.4m	-70.290
3.25G	335.7m	-321.00	1.579	-312.0	238m	55.30	626.1m	-75.550
3.5G	258.5m	-352.10	1.697	-326.7	264.9m	43.14	575.5m	-78.930
3.75G	212.7m	-22.90	1.723	-338.6	284m	32.81	549.8m	-81.490
4G	189.9m	-51.60	1.729	-348.9	298.7m	23.80	536.3m	-84.470

MAX2351/4/8/9/MAX2530/1/7/8

Quadruple-Mode PCS/Cellular/GPS LNA/Mixers

MAX2351/4/8/9/MAX2530/1/7/8

Table 8. S-Parameters for PCS LNA in HGHL Mode

FREQUENCY (Hz)	S11		S21		S12		S22	
	MAG	PHASE (DEG)	MAG	PHASE (DEG)	MAG	PHASE (DEG)	MAG	PHASE (DEG)
100M	826.3m	-18.04	28.510	163.100	8.437m	86.50	947.8m	-7.457
200M	730m	-33.35	25.050	141.400	15.81m	72.78	870.8m	-25.890
300M	623.7m	-44.60	21.350	125.200	21.38m	64.46	795.4m	-38.050
400M	530.6m	-52.40	18.100	112.300	25.89m	58.80	740.8m	-47.460
500M	508.6m	-55.46	14.650	106.400	25.66m	58.70	583.3m	-53.250
600M	419.8m	-62.24	13.410	94.840	32.75m	54.65	657.3m	-58.520
700M	379.3m	-65.01	11.750	87.380	36.18m	52.16	647.1m	-64.100
800M	351.2m	-67.46	10.450	80.970	39.47m	50.17	642.7m	-68.980
900M	329.5m	-69.90	9.419	75.050	42.7m	48.26	643.4m	-73.540
1G	310.7m	-72.33	8.565	69.280	45.59m	46.42	647.5m	-77.870
1.1G	293.7m	-74.30	7.822	63.670	48.5m	44.57	652.1m	-81.950
1.2G	280.4m	-75.57	7.158	58.350	51.34m	42.79	657.4m	-85.690
1.3G	271.9m	-76.33	6.573	53.390	54.13m	40.96	663.8m	-89.130
1.4G	267.7m	-76.88	6.065	48.740	56.8m	39.06	672.2m	-92.320
1.5G	266.6m	-77.55	5.622	44.290	59.33m	37.14	682.5m	-95.320
1.6G	267.8m	-78.48	5.233	40.010	61.75m	35.20	693.8m	-98.200
1.7G	270.5m	-79.62	4.887	35.860	64.01m	33.18	705.1m	-101.000
1.8G	274.6m	-80.87	4.576	31.840	66.01m	31.12	715.9m	-103.600
1.9G	280.4m	-82.23	4.296	27.970	67.69m	29.12	726.3m	-106.100
1.91G	281.1m	-82.38	4.270	27.600	67.84m	28.93	727.3m	-106.300
1.92G	281.8m	-82.53	4.244	27.220	67.99m	28.74	728.4m	-106.600
1.93G	282.5m	-82.68	4.218	26.840	68.14m	28.55	729.4m	-106.800
1.94G	283.2m	-82.82	4.192	26.470	68.28m	28.36	730.4m	-107.000
1.95G	284m	-82.98	4.167	26.090	68.43m	28.18	731.5m	-107.300
1.96G	284.8m	-83.13	4.142	25.720	68.57m	27.99	732.5m	-107.500
1.97G	285.6m	-83.29	4.117	25.350	68.71m	27.81	733.5m	-107.700
1.98G	286.4m	-83.45	4.093	24.980	68.85m	27.63	734.5m	-108.000
1.99G	287.2m	-83.61	4.069	24.610	68.99m	27.45	735.6m	-108.200
2G	288m	-83.77	4.045	24.250	69.12m	27.27	736.6m	-108.400
2.1G	297.2m	-85.53	3.818	20.650	70.37m	25.57	747m	-110.600
2.2G	307.7m	-87.49	3.614	17.180	71.48m	24.03	757.6m	-112.700
2.3G	319.5m	-89.65	3.429	13.830	72.5m	22.66	768.5m	-114.600
2.4G	332.6m	-92.00	3.264	10.590	73.47m	21.46	779.7m	-116.600
2.5G	346.9m	-94.53	3.116	7.455	74.47m	20.45	791.3m	-118.400
2.6G	362.5m	-97.25	2.984	4.420	75.59m	19.61	803.2m	-120.300
2.7G	379.7m	-100.20	2.870	1.4740	76.93m	18.96	815.5m	-122.100
2.8G	398.1m	-103.60	2.775	-1.475	78.78m	18.45	828.4m	-124.000
2.9G	415.5m	-107.70	2.697	-4.627	81.42m	17.73	840.5m	-126.000
3G	428.9m	-112.50	2.622	-8.150	84.47m	16.44	849.8m	-127.900

Quadruple-Mode PCS/Cellular/GPS LNA/Mixers

MAX2351/4/8/9/MAX2530/1/7/8

Table 9. S-Parameters for GPS LNA

FREQUENCY (Hz)	S11		S21		S12		S22	
	MAG	PHASE (DEG)	MAG	PHASE (DEG)	MAG	PHASE (DEG)	MAG	PHASE (DEG)
100M	897m	-8.953	391.4m	-106.5	279.4μ	142.10	996.2m	-6.446
200M	878.4m	-17.210	640.8m	-109.6	645.4μ	131.50	989.8m	-12.850
300M	859m	-25.060	892.3m	-106.4	883.4μ	150.50	980.7m	-19.390
400M	839.1m	-32.680	1.231	-104.0	1.579m	178.90	968.7m	-26.200
500M	818.7m	-40.390	1.691	-104.3	3.26m	191.20	953.2m	-33.480
600M	802.3m	-47.710	2.249	-107.0	5.893m	194.80	933.8m	-41.400
700M	787.6m	-55.560	2.97	-111.9	10m	192.70	907.6m	-50.410
800M	772m	-64.070	3.867	-119.2	15.78m	187.20	869.1m	-60.940
900M	751.1m	-73.420	4.916	-129.2	23.39m	179.40	810.1m	-73.480
1G	718.6m	-83.770	6.029	-141.6	32.81m	169.50	720.9m	-88.550
1.1G	666.6m	-94.890	7.037	-155.9	43.28m	157.90	596.2m	-106.500
1.2G	593.1m	-105.900	7.742	-171.2	53.35m	145.40	444.7m	-128.200
1.3G	506.2m	-115.600	8.033	-186.2	61.65m	133.30	293.1m	-156.200
1.4G	419.5m	-123.100	7.955	-199.9	67.69m	122.40	186.2m	-199.700
1.5G	344m	-127.900	7.64	-211.7	71.78m	113.30	177.6m	-255.300
1.51G	337.2m	-128.200	7.601	-212.8	72.11m	112.50	181.8m	-260.000
1.52G	330.7m	-128.500	7.561	-213.9	72.43m	111.70	186.6m	-264.400
1.53G	324.3m	-128.800	7.52	-214.9	72.73m	110.90	191.8m	-268.500
1.54G	318m	-129.000	7.479	-216.0	73.03m	110.10	197.4m	-272.400
1.55G	311.9m	-129.300	7.437	-217.0	73.32m	109.30	203.3m	-276.000
1.56G	306m	-129.500	7.394	-218.0	73.59m	108.60	209.5m	-279.500
1.57G	300.2m	-129.600	7.351	-219.0	73.86m	107.90	215.8m	-282.700
1.58G	294.6m	-129.800	7.307	-219.9	74.12m	107.20	222.3m	-285.700
1.59G	289.2m	-129.900	7.263	-220.9	74.38m	106.50	228.9m	-288.500
1.6G	283.9m	-130.000	7.219	-221.8	74.62m	105.80	235.5m	-291.100
1.7G	239.4m	-130.000	6.777	-230.4	76.78m	99.70	300.4m	-311.100
1.8G	208m	-128.700	6.359	-237.7	78.68m	94.75	356.2m	-324.000
1.9G	186m	-126.900	5.979	-244.1	80.58m	90.66	401.9m	-333.500
2G	170.2m	-124.800	5.637	-249.9	82.6m	87.15	439.3m	-341.000
2.1G	158.8m	-122.800	5.328	-255.0	84.75m	84.05	469.6m	-347.300
2.2G	150.9m	-120.900	5.05	-259.7	86.99m	81.26	494.3m	-352.800
2.3G	145.5m	-119.300	4.802	-264.0	89.28m	78.68	514.2m	-357.600
2.4G	142.1m	-118.200	4.58	-268.0	91.57m	76.29	530m	-2.000
2.5G	139.8m	-117.500	4.382	-271.7	93.8m	74.07	542.2m	-6.000
2.6G	138.3m	-117.200	4.204	-275.2	95.98m	72.04	551.3m	-9.700
2.7G	137m	-117.400	4.044	-278.5	98.11m	70.19	558m	-13.100
2.8G	133.5m	-117.700	3.895	-281.8	100.1m	68.60	562.3m	-16.100
2.9G	128.4m	-114.600	3.727	-285.1	102.5m	67.51	567m	-18.600
3G	139.9m	-109.200	3.557	-287.2	106m	66.24	574.8m	-21.200

Quadruple-Mode PCS/Cellular/GPS LNA/Mixers

MAX2351/4/8/9/MAX2530/1/7/8

Table 9. S-Parameters for GPS LNA (continued)

FREQUENCY (Hz)	S11		S21		S12		S22	
	MAG	PHASE (DEG)	MAG	PHASE (DEG)	MAG	PHASE (DEG)	MAG	PHASE (DEG)
3.1G	162.7m	-110.6	3.458	-288.7	109.3m	64.45	579.9m	-24.1
3.2G	182.9m	-117.0	3.422	-290.4	111.8m	62.71	581.1m	-26.8
3.3G	193.1m	-126.3	3.422	-293.0	113.9m	61.32	580.5m	-29.2
3.4G	187.8m	-135.5	3.405	-296.5	116.3m	60.27	580.1m	-31.4
3.5G	173.9m	-141.5	3.340	-300.1	119.1m	59.34	580.8m	-33.4
3.6G	161.5m	-144.5	3.251	-303.4	122.2m	58.40	581.9m	-35.3
3.7G	153.7m	-145.6	3.161	-306.2	125.5m	57.45	582.9m	-37.3
3.8G	150m	-146.3	3.080	-308.8	128.9m	56.54	584m	-39.1
3.9G	149.2m	-146.9	3.008	-311.2	132.4m	55.68	585.3m	-41.0
4G	150.3m	-147.8	2.945	-313.5	136.2m	54.86	587m	-42.7

Table 10. S-Parameters for Cellular Mixer in High-Linearity Mode

FREQUENCY (Hz)	S11	
	MAG	PHASE (DEG)
100M	997.8m	-6.397
200M	993.1m	-13.080
300M	984.5m	-20.480
400M	968.2m	-29.270
500M	941.8m	-40.340
600M	879m	-56.150
700M	739.9m	-80.690
800M	475.4m	-123.700
810M	444.8m	-129.900
820M	414.7m	-136.700
830M	385.9m	-144.100
840M	359.1m	-152.300
850M	335.2m	-161.200
860M	314.9m	-170.900
870M	299.3m	-181.400

FREQUENCY (MHz)	S11	
	MAG	PHASE (DEG)
880M	289m	-192.4
890M	284.4m	-203.5
900M	285.5m	-214.6
1G	451.9m	-286.0
1.25G	734.2m	-337.2
1.5G	815.1m	-356.3
1.75G	846.4m	-8.0
2G	860.2m	-16.9
2.25G	864.6m	-16.9
2.5G	862m	-16.9
2.75G	850.6m	-16.9
3G	846.6m	-16.9
3.25G	857.1m	-16.9
3.5G	860.5m	-16.9
3.75G	857.2m	-16.9
4G	849.3m	-16.9

Quadruple-Mode PCS/Cellular/GPS LNA/Mixers

Table 11. S-Parameters for PCS Mixer in High Linearity Mode

FREQUENCY (Hz)	S11	
	MAG	PHASE (DEG)
100M	949.1m	-3.234
200M	942.3m	-6.090
300M	933.3m	-8.977
400M	922.8m	-11.780
500M	904.9m	-14.700
600M	895.6m	-17.390
700M	881.2m	-20.300
800M	863.9m	-23.310
900M	845.8m	-26.410
1G	826.6m	-29.830
1.1G	804m	-33.700
1.2G	776.7m	-38.130
1.3G	742.2m	-43.330
1.4G	696.8m	-49.580
1.5G	635.2m	-57.090
1.6G	554.4m	-66.040
1.7G	454.4m	-77.180
1.8G	335.7m	-92.710
1.9G	207.5m	-120.400
1.91G	195.6m	-124.700
1.92G	184.3m	-129.500
1.93G	173.7m	-134.800
1.94G	164.1m	-140.700
1.95G	155.7m	-147.200

FREQUENCY (Hz)	S11	
	MAG	PHASE (DEG)
1.96G	148.7m	-154.3
1.97G	143.5m	-162.0
1.98G	140.2m	-170.2
1.99G	139.2m	-178.6
2G	140.4m	-187.2
2.1G	244.9m	-246.7
2.2G	402.9m	-273.1
2.3G	551.8m	-290.0
2.4G	675.8m	-302.9
2.5G	773.9m	-313.4
2.6G	851.9m	-322.3
2.7G	911.7m	-330.3
2.8G	948.5m	-337.6
2.9G	964m	-343.9
3G	964.3m	-349.2
3.1G	956.1m	-353.4
3.2G	944.9m	-356.6
3.3G	934.5m	-359.1
3.4G	928m	-1.0
3.5G	926.9m	-2.7
3.6G	929.9m	-4.2
3.7G	934.9m	-5.8
3.8G	939.9m	-7.4
3.9G	944.2m	-9.1
4G	947.8m	-10.6

MAX2351/4/8/9/MAX2530/1/7/8

Quadruple-Mode PCS/Cellular/GPS LNA/Mixers

MAX2351/4/8/9/MAX2530/1/7/8

Table 12. S-Parameters for GPS Mixer in High Linearity Mode

FREQUENCY (Hz)	S11	
	MAG	PHASE (DEG)
100M	955.2m	-3.662
200M	947.6m	-6.944
300M	938m	-10.250
400M	926.8m	-13.550
500M	910.8m	-16.840
600M	896m	-20.300
700M	877.6m	-23.970
800M	854.6m	-27.950
900M	825.7m	-32.250
1G	790.1m	-37.090
1.1G	743.8m	-42.690
1.2G	681.1m	-49.330
1.3G	594.6m	-57.350
1.4G	474.7m	-67.280
1.5G	307.7m	-79.620
1.51G	288.2m	-80.960
1.52G	268.2m	-82.330
1.53G	247.7m	-83.700
1.54G	226.8m	-85.080
1.55G	205.4m	-86.460
1.56G	183.7m	-87.840
1.57G	161.5m	-89.200
1.58G	139m	-90.520
1.59G	116.2m	-91.770

FREQUENCY (Hz)	S11	
	MAG	PHASE (DEG)
1.6G	93.14m	-92.870
1.7G	143.3m	67.370
1.8G	357.5m	53.140
1.9G	522.6m	40.470
2G	639m	30.150
2.1G	718.6m	21.880
2.2G	772.8m	15.230
2.3G	811.4m	9.874
2.4G	842.9m	5.410
2.5G	869.8m	1.356
2.6G	890.8m	-2.443
2.7G	906.1m	-5.968
2.8G	916.8m	-9.216
2.9G	924m	-12.200
3G	928.9m	-14.940
3.1G	932.3m	-17.490
3.2G	934.5m	-19.880
3.3G	935.8m	-22.150
3.4G	936.4m	-24.300
3.5G	936.4m	-26.360
3.6G	936m	-28.340
3.7G	935.3m	-30.240
3.8G	934.3m	-32.080
3.9G	933.1m	-33.880
4G	931.7m	-35.620

Quadruple-Mode PCS/Cellular/GPS LNA/Mixers

Table 13. Noise Parameters for Cellular LNA in HGHL Mode

FREQUENCY (MHz)	NF _{MIN} (dB)	Γ _{OPT}	∠Γ _{OPT}	R _N (Ω)
700	0.75	0.15	107	4.0
800	0.76	0.16	117	3.9
810	0.76	0.16	118	3.9
820	0.76	0.17	119	3.8
830	0.76	0.17	120	3.8
840	0.77	0.17	121	3.8
850	0.77	0.17	122	3.8
860	0.78	0.17	123	3.8
870	0.77	0.17	123	3.8
880	0.77	0.17	124	3.8
890	0.77	0.17	125	3.7
900	0.78	0.18	126	3.7
1000	0.79	0.19	134	3.6

Table 14. Noise Parameters for PCS LNA in HGHL Mode

FREQUENCY (MHz)	NF _{MIN} (dB)	Γ _{OPT}	∠Γ _{OPT}	R _N (Ω)
1800	0.89	0.22	-123	4.3
1900	0.89	0.19	-129	4.2
1910	0.89	0.19	-130	4.2
1920	0.89	0.19	-131	4.2
1930	0.89	0.18	-131	4.2
1940	0.90	0.18	-133	4.1
1950	0.90	0.18	-134	4.1
1960	0.90	0.18	-134	4.1
1970	0.90	0.18	-135	4.1
1980	0.90	0.18	-136	4.1
1990	0.90	0.18	-137	4.1
2000	0.90	0.17	-138	4.1
2100	0.91	0.17	-147	4.0

Table 15. Noise Parameters for GPS LNA in HGHL Mode

FREQUENCY (MHz)	NF _{MIN} (dB)	Γ _{OPT}	∠Γ _{OPT}	R _N (Ω)
1400	0.71	0.20	78	4.7
1500	0.73	0.19	84	4.6
1510	0.74	0.19	85	4.6
1520	0.74	0.19	85	4.6
1530	0.74	0.19	86	4.6
1540	0.74	0.19	86	4.6
1550	0.75	0.19	87	4.6
1560	0.75	0.19	87	4.6
1570	0.75	0.19	88	4.6
1580	0.75	0.19	88	4.6

Chip Information

TRANSISTOR COUNT: 2538

PROCESS: BiCMOS

MAX2351/4/8/9/MAX2530/1/7/8

Quadruple-Mode PCS/Cellular/GPS LNA/Mixers

Pin Configurations (continued)

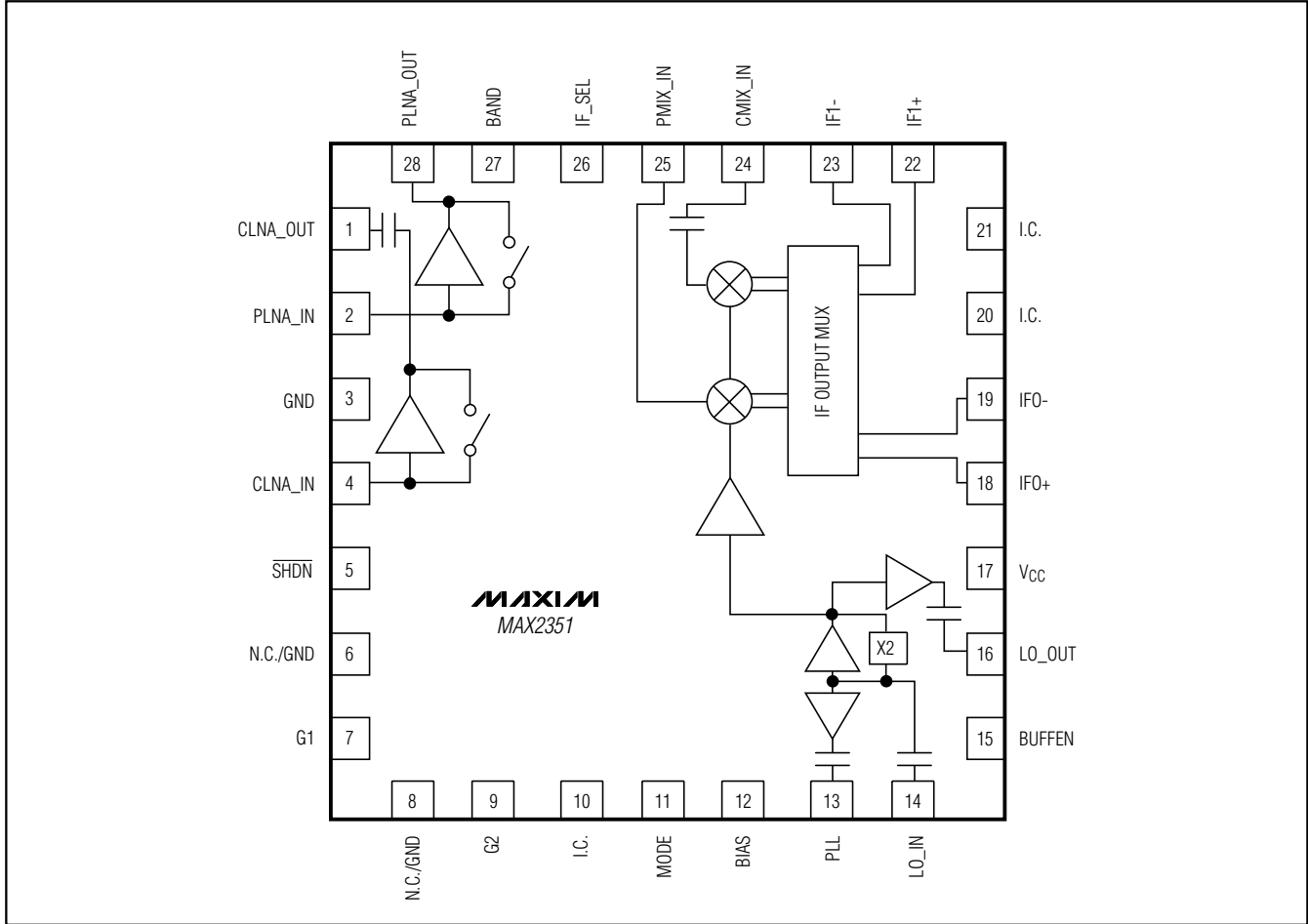

MAX2351/4/8/9/MAX2530/1/7/8

Quadruple-Mode PCS/Cellular/GPS LNA/Mixers

Pin Configurations (continued)

MAX2351/4/8/9/MAX2530/1/7/8

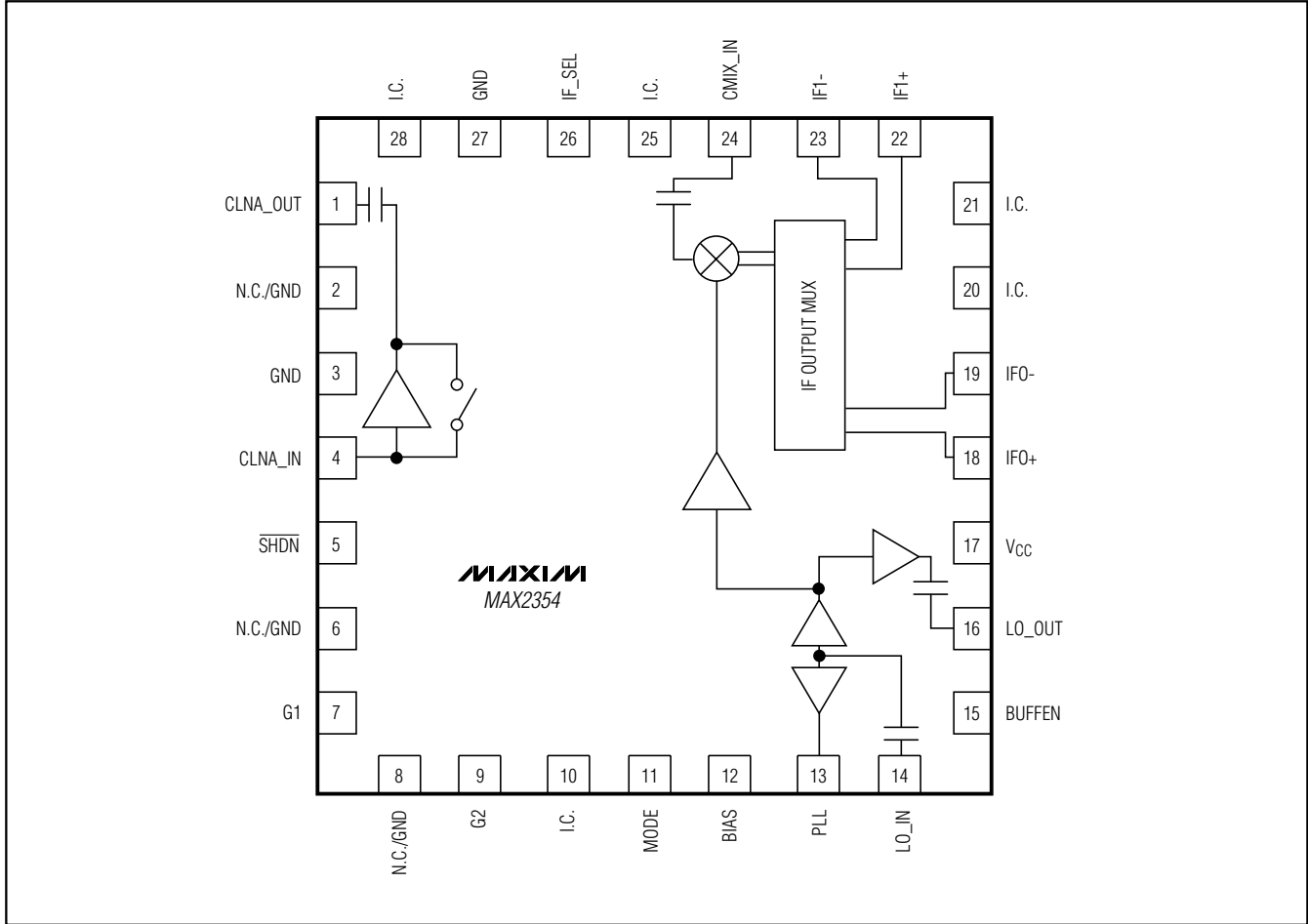

Quadruple-Mode PCS/Cellular/GPS LNA/Mixers

Pin Configurations (continued)

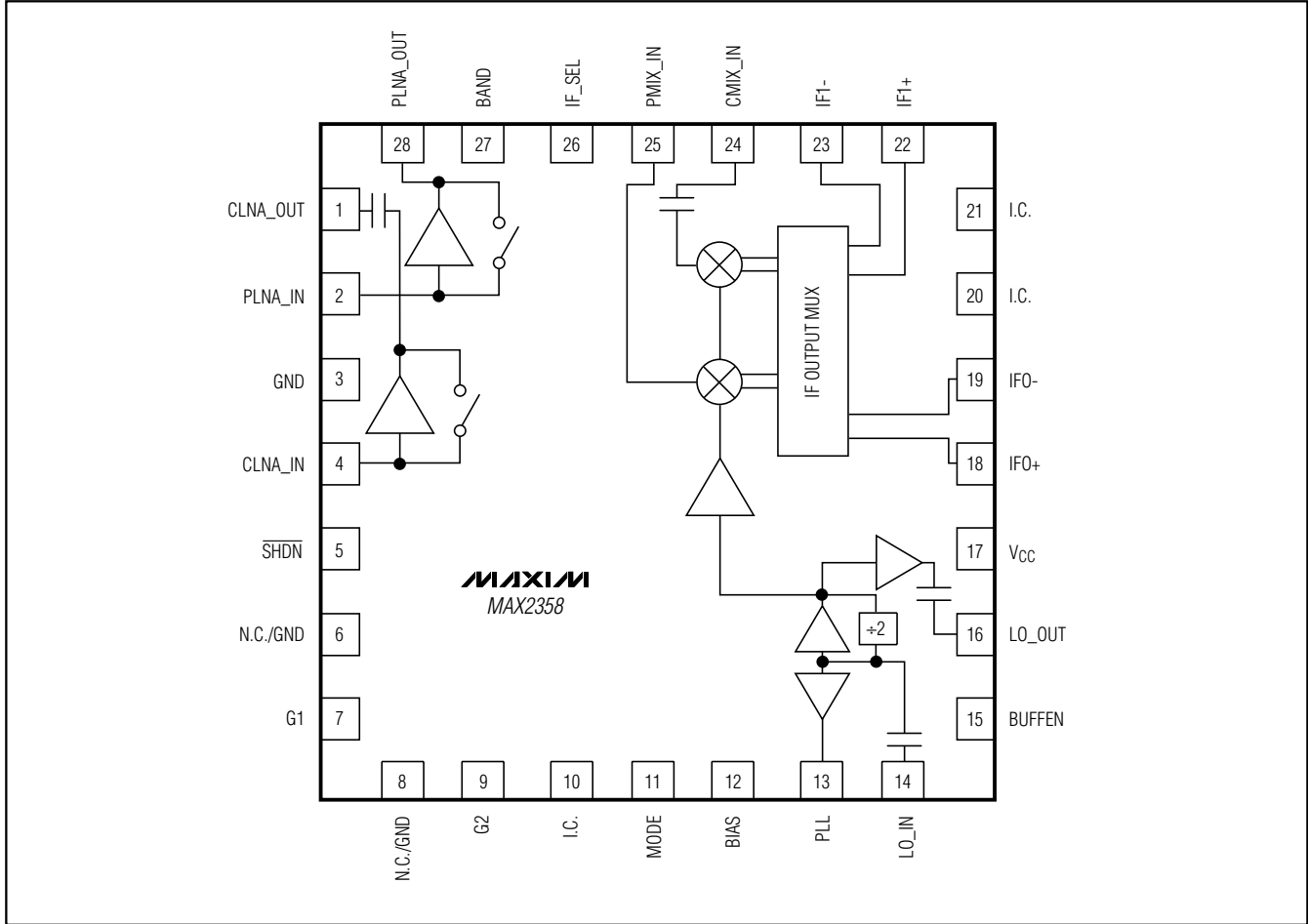

MAX2351/4/8/9/MAX2530/1/7/8

Quadruple-Mode PCS/Cellular/GPS LNA/Mixers

MAX2351/4/8/9/MAX2530/1/7/8

Pin Configurations (continued)

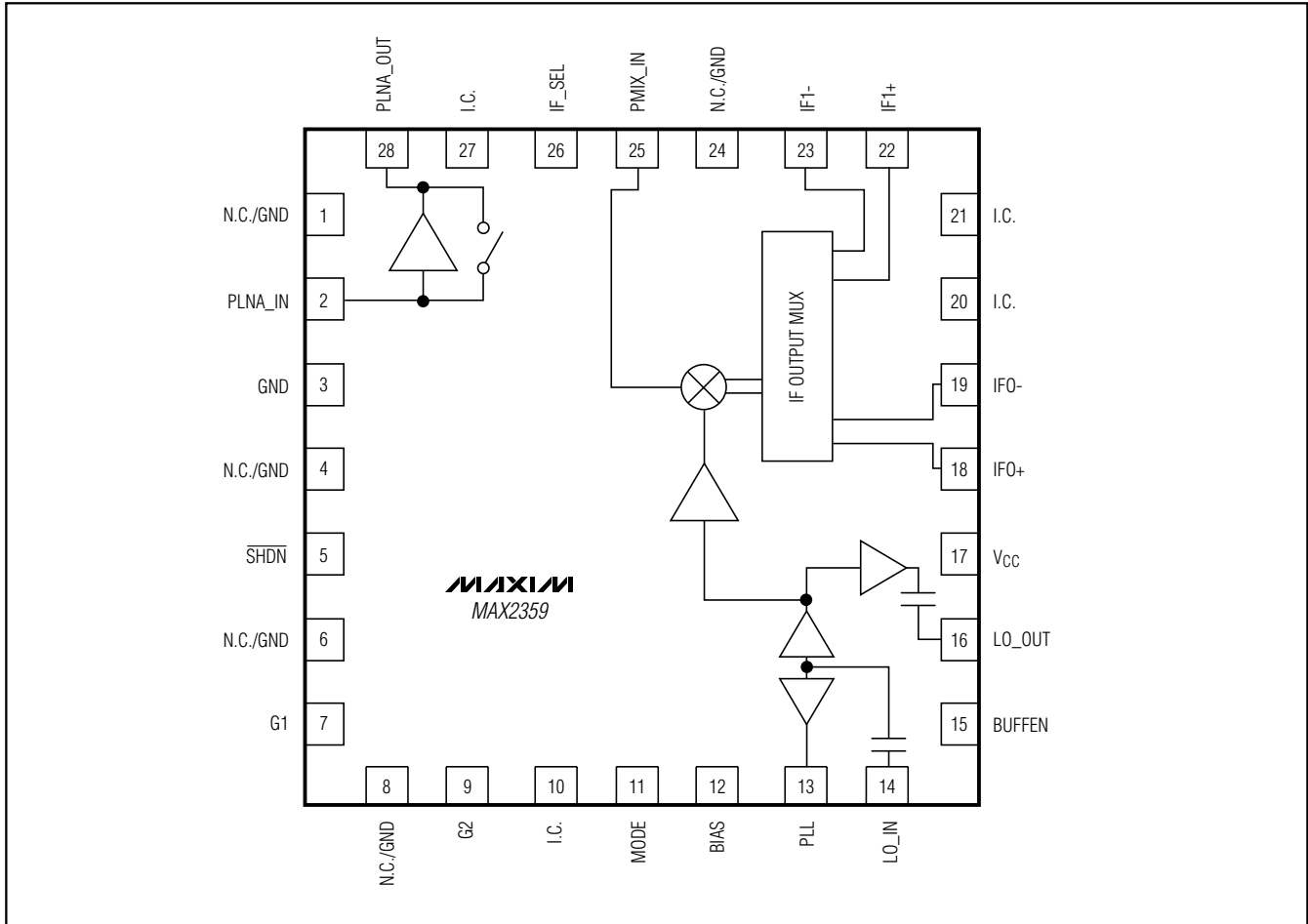

Quadruple-Mode PCS/Cellular/GPS LNA/Mixers

Pin Configurations (continued)

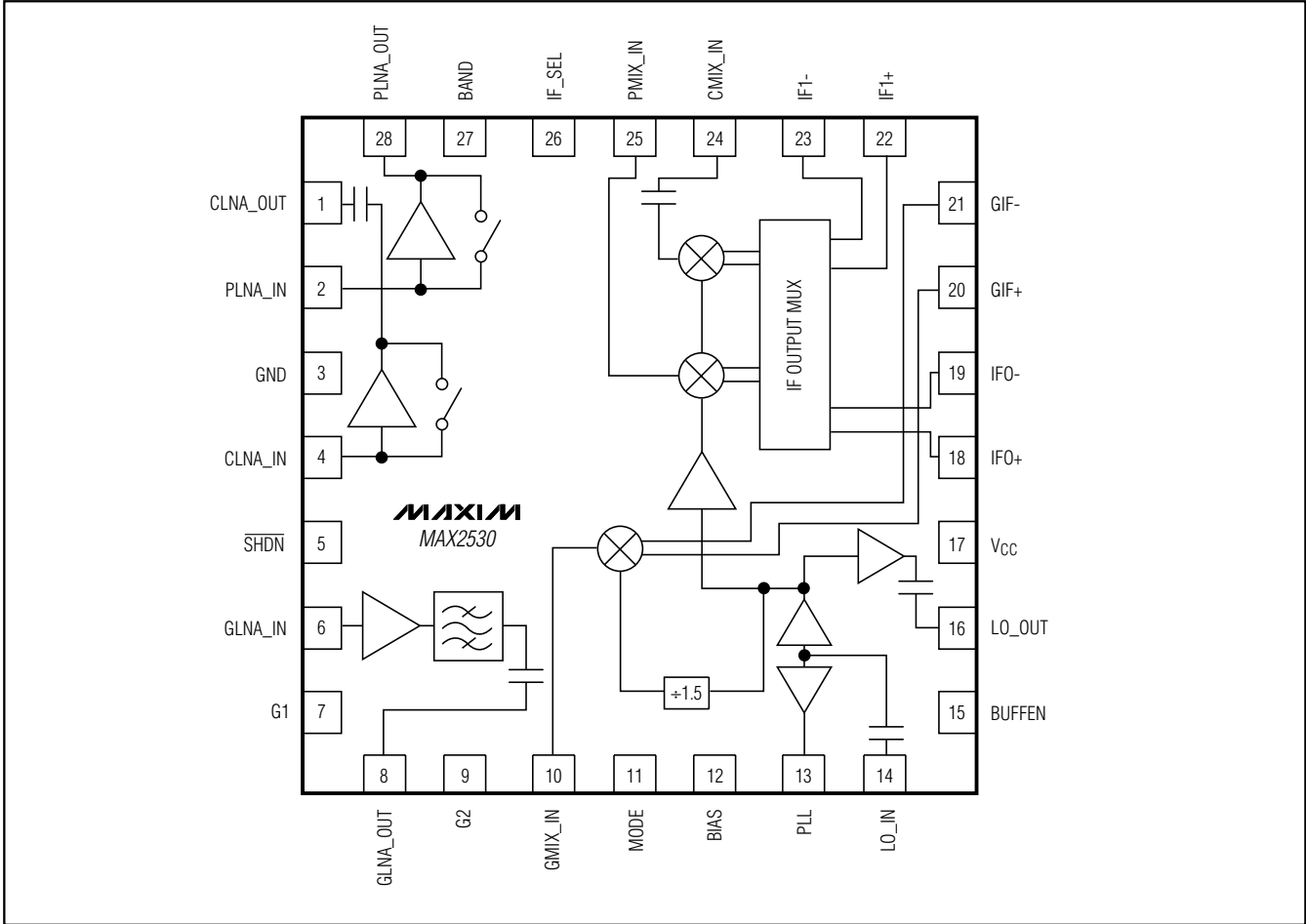

MAX2351/4/8/9/MAX2530/1/7/8

Quadruple-Mode PCS/Cellular/GPS LNA/Mixers

MAX2351/4/8/9/MAX2530/1/7/8

Pin Configurations (continued)

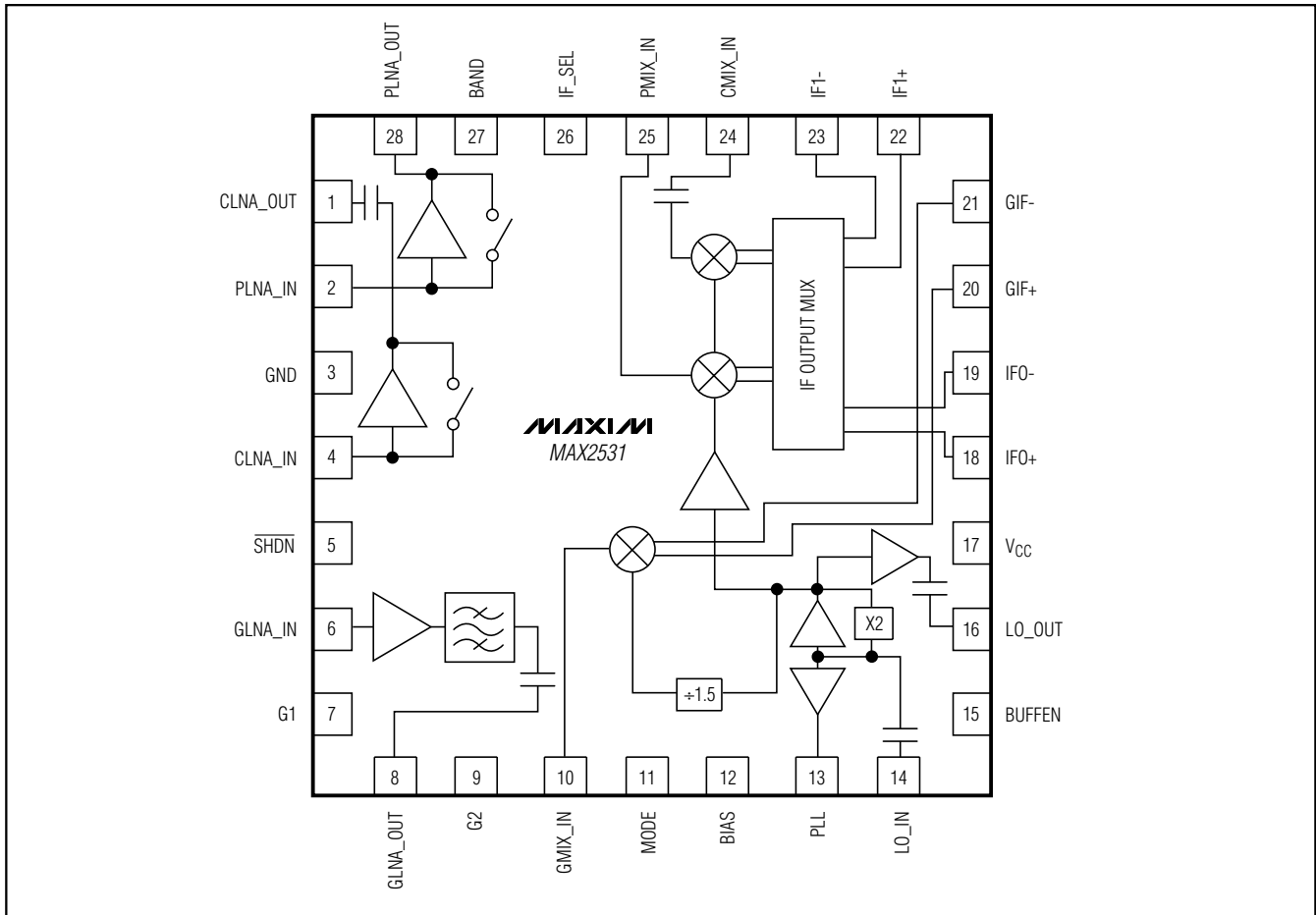

Quadruple-Mode PCS/Cellular/GPS LNA/Mixers

Pin Configurations (continued)

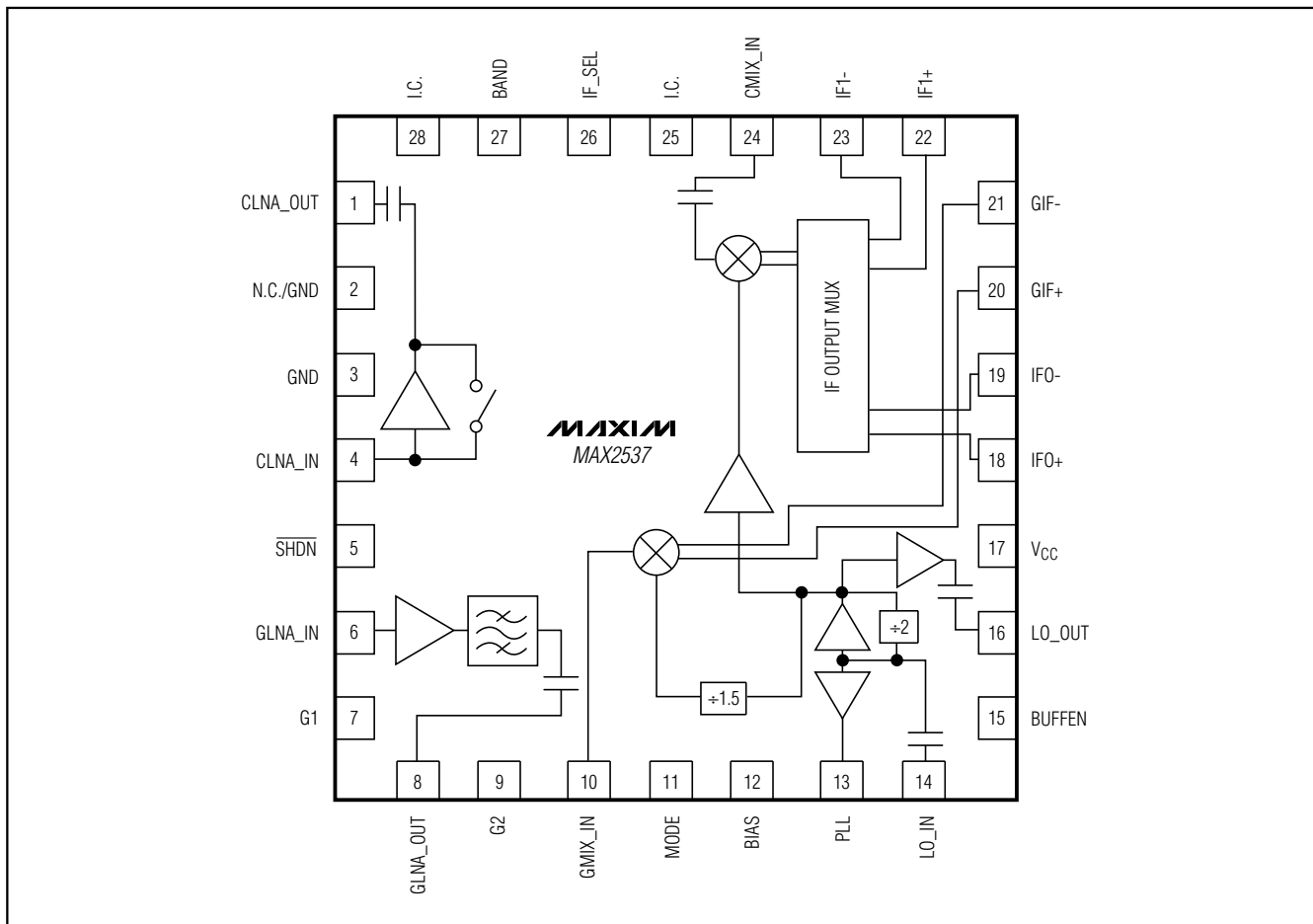

MAX2351/4/8/9/MAX2530/1/7/8

Package Information

For the latest package outline information, go to www.maxim-ic.com/packages.

Maxim cannot assume responsibility for use of any circuitry other than circuitry entirely embodied in a Maxim product. No circuit patent licenses are implied. Maxim reserves the right to change the circuitry and specifications without notice at any time.

Maxim Integrated Products, 120 San Gabriel Drive, Sunnyvale, CA 94086 408-737-7600 _____ 27

Looking for pricing, stock, or lifecycle information?

Click below to explore more details on WIN SOURCE:

 [View MAX2538ETI-T on WIN SOURCE](#)

 [Maxim Integrated](#) Information

Optimize Your Supply Chain with WIN SOURCE Solutions

-  Global Sourcing Solution
-  Obsolete Management
-  Cost Control Management
-  Shortage Management
-  Alternative Solution
-  Excess Inventory Management