



# THE DATASHEET OF MAX232N



# MAX232 Dual EIA-232 Drivers and Receivers

## 1 Features

- Meets or exceeds TIA/EIA-232-F and ITU recommendation V.28
- Operates from a single 5V power supply with 1μF charge-pump capacitors
- Operates up to 120kbit/s
- Two drivers and two receivers
- ±30V Input levels
- Low supply current: 8mA typical
- ESD protection exceeds JESD 22
  - 2000V Human-body model (A114-A)
- Upgrade with improved ESD (15kV HBM) and 0.1μF charge-pump capacitors is available with the MAX202 device

## 2 Applications

- TIA/EIA-232-F
- [Battery-powered systems](#)
- Terminals
- Modems
- Computers

## 3 Description

The MAX232 device is a dual driver/receiver that includes a capacitive voltage generator to supply TIA/EIA-232-F voltage levels from a single 5V supply. Each receiver converts TIA/EIA-232-F inputs to 5V TTL/CMOS levels. These receivers have a typical threshold of 1.3 V, a typical hysteresis of 0.5V, and can accept ±30V inputs. Each driver converts TTL/CMOS input levels into TIA/EIA-232-F levels.

### Package Information

PART NUMBER	PACKAGE <sup>(1)</sup>	PACKAGE SIZE <sup>(2)</sup>
MAX232	SOIC (16)	9.9mm × 6mm
	SOIC (16)	10.4mm × 10.3mm
	PDIP (16)	19.3mm × 9mm
	SOP (16)	10.2mm × 7.8 mm

- (1) For more information, see [Section 11](#).
- (2) The package size (length × width) is a nominal value and includes pins, where applicable.

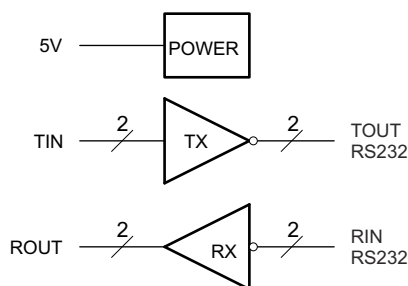

**Simplified Schematic**



## Table of Contents

<b>1 Features</b> .....	1	7.2 Functional Block Diagram.....	9
<b>2 Applications</b> .....	1	7.3 Feature Description.....	9
<b>3 Description</b> .....	1	7.4 Device Functional Modes.....	9
<b>4 Pin Configuration and Functions</b> .....	3	<b>8 Application and Implementation</b> .....	10
<b>5 Specifications</b> .....	4	8.1 Application Information.....	10
5.1 Absolute Maximum Ratings <sup>(1)</sup> .....	4	8.2 Typical Application.....	10
5.2 ESD Ratings.....	4	8.3 Power Supply Recommendations.....	11
5.3 Recommended Operating Conditions.....	4	8.4 Layout.....	11
5.4 Thermal Information.....	4	<b>9 Device and Documentation Support</b> .....	12
5.5 Electrical Characteristics, Device.....	5	9.1 Receiving Notification of Documentation Updates....	12
5.6 Electrical Characteristics, Driver.....	5	9.2 Support Resources.....	12
5.7 Electrical Characteristics, Receiver.....	5	9.3 Trademarks.....	12
5.8 Switching Characteristics.....	5	9.4 Electrostatic Discharge Caution.....	12
5.9 Typical Characteristics.....	6	9.5 Glossary.....	12
<b>6 Parameter Measurement Information</b> .....	7	<b>10 Revision History</b> .....	12
<b>7 Detailed Description</b> .....	9	<b>11 Mechanical, Packaging, and Orderable Information</b> .....	12
7.1 Overview.....	9		

## 4 Pin Configuration and Functions

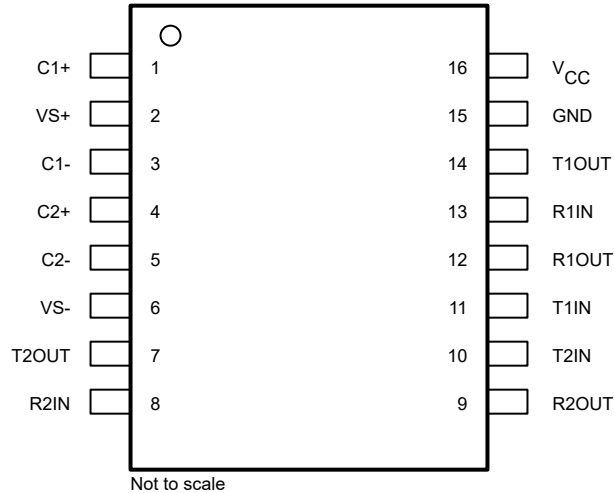

**Figure 4-1. MAX232: D, DW, N or NS Package  
MAX232I: D, DW, or N Package  
(Top View)**

**Table 4-1. Pin Functions**

PIN		TYPE	DESCRIPTION
NAME	NO.		
C1+	1	—	Positive lead of C1 capacitor
VS+	2	O	Positive charge pump output for storage capacitor only
C1-	3	—	Negative lead of C1 capacitor
C2+	4	—	Positive lead of C2 capacitor
C2-	5	—	Negative lead of C2 capacitor
VS-	6	O	Negative charge pump output for storage capacitor only
T2OUT	7	O	RS232 line data output (to remote RS232 system)
R2IN	8	I	RS232 line data input (from remote RS232 system)
R2OUT	9	O	Logic data output (to UART)
T2IN	10	I	Logic data input (from UART)
T1IN	11	I	Logic data input (from UART)
R1IN	13	I	RS232 line data input (from remote RS232 system)
T1OUT	14	O	RS232 line data output (to remote RS232 system)
GND	15	—	Ground
V <sub>CC</sub>	16	—	Supply Voltage, Connect to external 5V power supply

## 5 Specifications

### 5.1 Absolute Maximum Ratings<sup>(1)</sup>

over operating free-air temperature range (unless otherwise noted)

		MIN	MAX	UNIT
V <sub>CC</sub>	Input Supply voltage range <sup>(2)</sup>	-0.3	6	V
V <sub>S+</sub>	Positive output supply voltage range	V <sub>CC</sub> - 0.3	15	V
V <sub>S-</sub>	Negative output supply voltage range	-0.3	-15	V
V <sub>I</sub>	Input voltage range	T1IN, T2IN	V <sub>CC</sub> + 0.3	V
		R1IN, R2IN	±30	
V <sub>O</sub>	Output voltage range	T1OUT, T2OUT	V <sub>S-</sub> - 0.3    V <sub>S+</sub> + 0.3	V
		R1OUT, R2OUT	-0.3    V <sub>CC</sub> + 0.3	
Short-circuit duration		T1OUT, T2OUT		
		Unlimited		
T <sub>J</sub>	Operating virtual junction temperature	150		°C

- (1) Stresses beyond those listed under *Absolute Maximum Ratings* may cause permanent damage to the device. These are stress ratings only, and functional operation of the device at these or any other conditions beyond those indicated under *Recommended Operating Conditions* is not implied. Exposure to absolute-maximum-rated conditions for extended periods may affect device reliability.
- (2) All voltages are with respect to network GND.

### 5.2 ESD Ratings

		MIN	MAX	UNIT	
T <sub>stg</sub>	Storage temperature range	-65	150	°C	
V <sub>(ESD)</sub>	Electrostatic discharge	Human body model (HBM), per ANSI/ESDA/ JEDEC JS-001, all pins <sup>(1)</sup>	0	2000	V
		Charged device model (CDM), per JEDEC specification JESD22-C101, all pins <sup>(2)</sup>	0	1000	

- (1) JEDEC document JEP155 states that 500-V HBM allows safe manufacturing with a standard ESD control process.
- (2) JEDEC document JEP157 states that 250-V CDM allows safe manufacturing with a standard ESD control process.

### 5.3 Recommended Operating Conditions

		MIN	NOM	MAX	UNIT
V <sub>CC</sub>	Supply voltage	4.5	5	5.5	V
V <sub>IH</sub>	High-level input voltage (T1IN, T2IN)	2			V
V <sub>IL</sub>	Low-level input voltage (T1IN, T2IN)	0.8			V
R1IN, R2IN	Receiver input voltage	±30			V
T <sub>A</sub>	Operating free-air temperature	MAX232	0	70	°C
		MAX232I	-40	85	

### 5.4 Thermal Information

THERMAL METRIC <sup>(1)</sup>		SOIC (D)	SOIC wide (DW)	PDIP (N)	SOP (NS)	UNIT
		16 PINS	16 PINS	16 PINS	16 PINS	
R <sub>θJA</sub>	Junction-to-ambient thermal resistance	84.6	71.7	60.6	88.5	°C/W
R <sub>θJC(top)</sub>	Junction-to-case (top) thermal resistance	43.5	37.6	48.1	46.2	°C/W
R <sub>θJB</sub>	Junction-to-board thermal resistance	43.2	36.8	40.6	50.7	°C/W
ψ <sub>JT</sub>	Junction-to-top characterization parameter	10.4	13.3	27.5	13.5	°C/W
ψ <sub>JB</sub>	Junction-to-board characterization parameter	42.8	36.4	40.3	50.3	°C/W

- (1) For more information about traditional and new thermal metrics, see the *IC Package Thermal Metrics* application report ([SPRA953](#)).

## 5.5 Electrical Characteristics, Device

over recommended ranges of supply voltage and operating free-air temperature (unless otherwise noted) (see [Figure 8-1](#))

PARAMETER		TEST CONDITIONS <sup>(2)</sup>	MIN	TYP <sup>(1)</sup>	MAX	UNIT
I <sub>CC</sub>	Supply current	V <sub>CC</sub> = 5.5V, all outputs open, T <sub>A</sub> = 25°C		8	10	mA

- (1) All typical values are at V<sub>CC</sub> = 5V, and T<sub>A</sub> = 25°C.  
 (2) Test conditions are C1–C4 = 1μF at V<sub>CC</sub> = 5V ± 0.5V

## 5.6 Electrical Characteristics, Driver

over recommended ranges of supply voltage and operating free-air temperature (unless otherwise noted)

PARAMETER		TEST CONDITIONS <sup>(2)</sup>	MIN	TYP <sup>(1)</sup>	MAX	UNIT
V <sub>OH</sub>	High-level output voltage	T1OUT, T2OUT R <sub>L</sub> = 3kΩ to GND	5	7		V
V <sub>OL</sub>	Low-level output voltage <sup>(2)</sup>	T1OUT, T2OUT R <sub>L</sub> = 3kΩ to GND		–7	–5	V
r <sub>O</sub>	Output resistance	T1OUT, T2OUT V <sub>S+</sub> = V <sub>S–</sub> = 0, V <sub>O</sub> = ±2V	300			Ω
I <sub>OS</sub> <sup>(3)</sup>	Short-circuit output current	T1OUT, T2OUT V <sub>CC</sub> = 5.5V, V <sub>O</sub> = 0V		±10		mA
I <sub>IS</sub>	Short-circuit input current	T1IN, T2IN V <sub>I</sub> = 0			200	μA

- (1) All typical values are at V<sub>CC</sub> = 5V, T<sub>A</sub> = 25°C.  
 (2) The algebraic convention, in which the least-positive (most negative) value is designated minimum, is used in this data sheet for logic voltage levels only.  
 (3) Not more than one output should be shorted at a time.

## 5.7 Electrical Characteristics, Receiver

over recommended ranges of supply voltage and operating free-air temperature (unless otherwise noted)

PARAMETER		TEST CONDITIONS <sup>(3)</sup>	MIN	TYP <sup>(1)</sup>	MAX	UNIT
V <sub>OH</sub>	High-level output voltage	R1OUT, R2OUT I <sub>OH</sub> = –1mA	3.5			V
V <sub>OL</sub>	Low-level output voltage <sup>(2)</sup>	R1OUT, R2OUT I <sub>OL</sub> = 3.2mA			0.4	V
V <sub>IT+</sub>	Receiver positive-going input threshold voltage	R1IN, R2IN V <sub>CC</sub> = 5V, T <sub>A</sub> = 25°C		1.7	2.4	V
V <sub>IT–</sub>	Receiver negative-going input threshold voltage	R1IN, R2IN V <sub>CC</sub> = 5V, T <sub>A</sub> = 25°C	0.8	1.2		V
V <sub>hys</sub>	Input hysteresis voltage	R1IN, R2IN V <sub>CC</sub> = 5V	0.2	0.5	1	V
r <sub>I</sub>	Receiver input resistance	R1IN, R2IN V <sub>CC</sub> = 5V, T <sub>A</sub> = 25°C	3	5	7	kΩ

- (1) All typical values are at V<sub>CC</sub> = 5V, T<sub>A</sub> = 25°C.  
 (2) The algebraic convention, in which the least-positive (most negative) value is designated minimum, is used in this data sheet for logic voltage levels only.  
 (3) Test conditions are C1–C4 = 1μF at V<sub>CC</sub> = 5V ± 0.5V.

## 5.8 Switching Characteristics

over recommended ranges of supply voltage and operating free-air temperature (unless otherwise noted)

PARAMETER		TEST CONDITIONS <sup>(1)</sup>	MIN	TYP <sup>(1)</sup>	MAX	UNIT
SR	Driver slew rate	R <sub>L</sub> = 3kΩ to 7kΩ, see <a href="#">Figure 6-2</a>			30	V/μs
SR(t)	Driver transition region slew rate	see <a href="#">Figure 6-3</a>		3		V/μs
	Data rate	One TOUT switching		120		kbit/s
t <sub>PLH</sub> ®	Receiver propagation delay time, low- to high-level output	TTL load, see <a href="#">Figure 6-1</a>		500		ns
t <sub>PHL</sub> ®	Receiver propagation delay time, high- to low-level output	TTL load, see <a href="#">Figure 6-1</a>		500		ns

- (1) Test conditions are C1–C4 = 1μF at V<sub>CC</sub> = 5V ± 0.5V.

### 5.9 Typical Characteristics

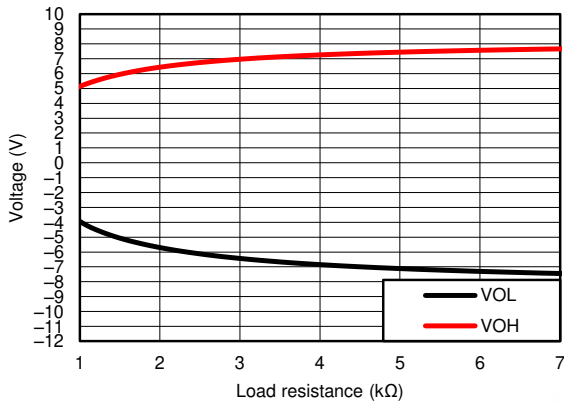

Figure 5-1. TOUT VOH & VOL vs Load Resistance, Both Drivers Loaded

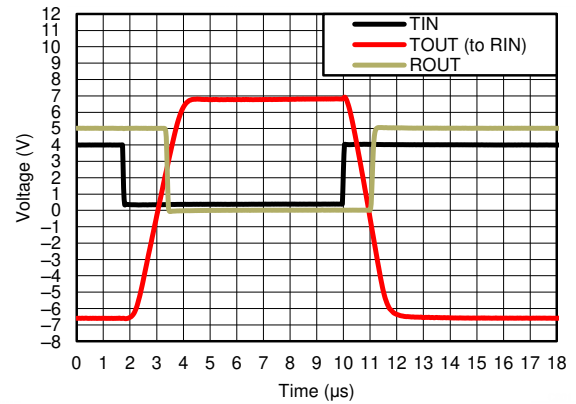
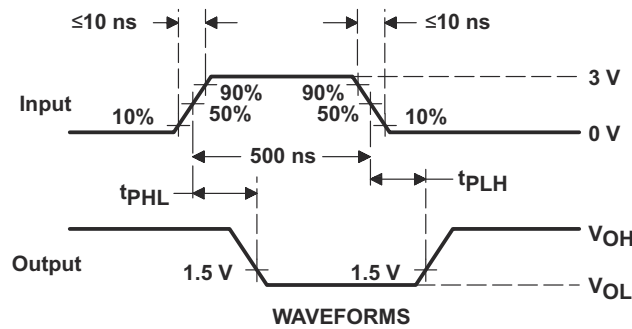
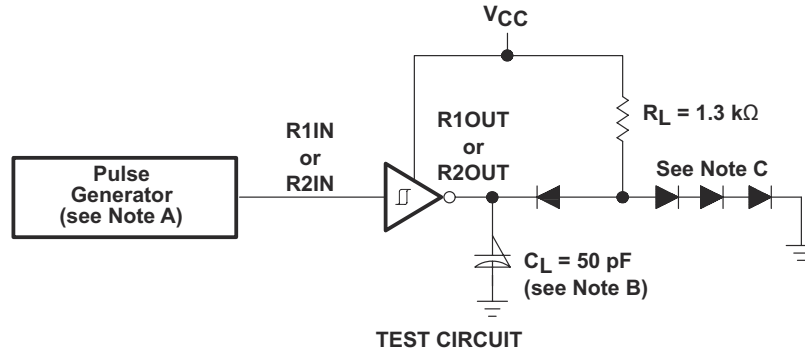

Figure 5-2. Driver to Receiver Loopback Timing Waveform

## 6 Parameter Measurement Information



- A. The pulse generator has the following characteristics:  $Z_O = 50\Omega$ , duty cycle  $\leq 50\%$ .
- B.  $C_L$  includes probe and jig capacitance.
- C. All diodes are 1N3064 or equivalent.

Figure 6-1. Receiver Test Circuit and Waveforms for  $t_{PHL}$  and  $t_{PLH}$  Measurements

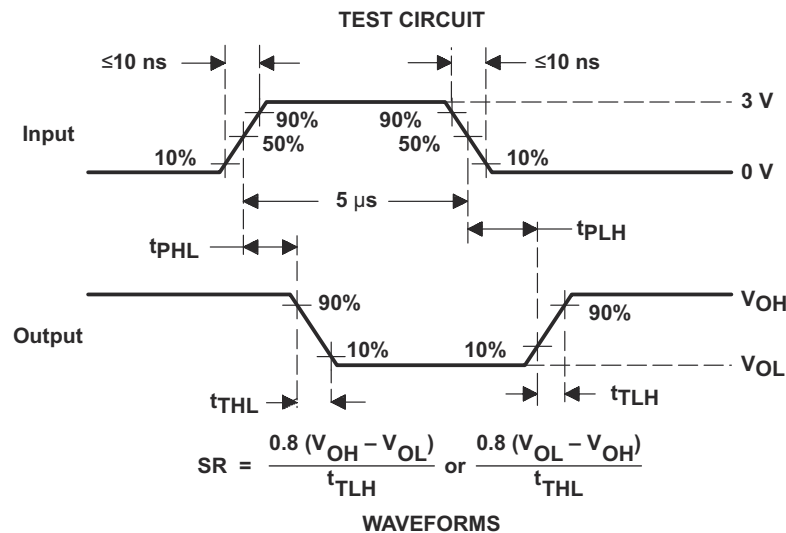
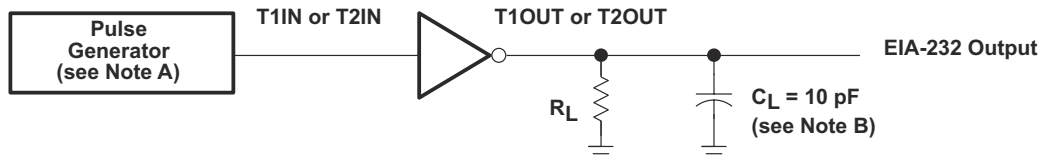

- A. The pulse generator has the following characteristics:  $Z_O = 50\Omega$ , duty cycle  $\leq 50\%$ .
- B.  $C_L$  includes probe and jig capacitance.

Figure 6-2. Driver Test Circuit and Waveforms for  $t_{PHL}$  and  $t_{PLH}$  Measurements (5μs Input)

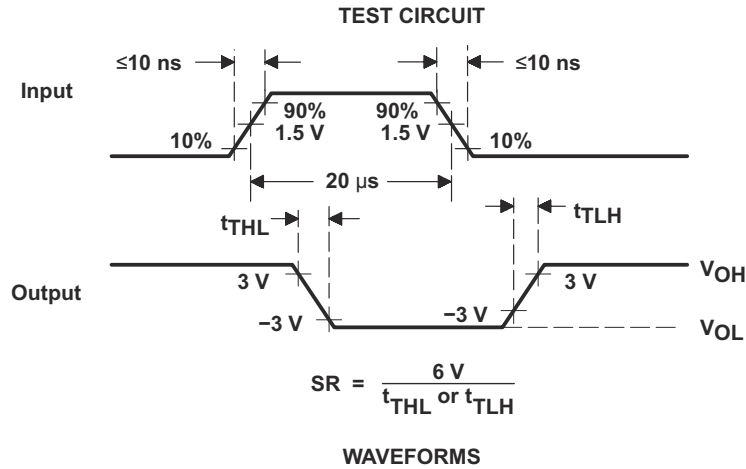
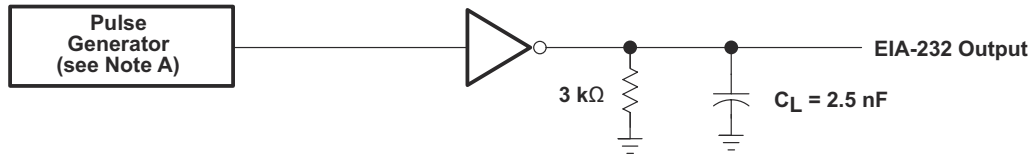

- A. The pulse generator has the following characteristics:  $Z_O = 50\Omega$ , duty cycle  $\leq 50\%$ .

**Figure 6-3. Test Circuit and Waveforms for  $t_{THL}$  and  $t_{TLH}$  Measurements (20μs Input)**

## 7 Detailed Description

### 7.1 Overview

The MAX232 device is a dual driver/receiver that includes a capacitive voltage generator using four capacitors to supply TIA/EIA-232-F voltage levels from a single 5-V supply. Each receiver converts TIA/EIA-232-F inputs to 5-V TTL/CMOS levels. These receivers have a typical threshold of 1.3 V, a typical hysteresis of 0.5 V, and can accept  $\pm 30$ -V inputs. Each driver converts TTL/CMOS input levels into TIA/EIA-232-F levels. The driver, receiver, and voltage-generator functions are available as cells in the Texas Instruments LinASIC™ library. Outputs are protected against shorts to ground.

### 7.2 Functional Block Diagram

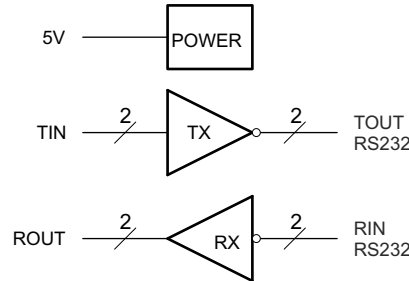

### 7.3 Feature Description

#### 7.3.1 Power

The power block increases and inverts the 5V supply for the RS232 driver using a charge pump that requires four 1 $\mu$ F external capacitors.

#### 7.3.2 RS232 Driver

Two drivers interface standard logic level to RS232 levels. Internal pull up resistors on TIN inputs ensures a high input when the line is high impedance.

#### 7.3.3 RS232 Receiver

Two receivers interface RS232 levels to standard logic levels. An open input will result in a high output on ROUT.

### 7.4 Device Functional Modes

#### 7.4.1 V<sub>CC</sub> powered by 5V

The device will be in normal operation.

#### 7.4.2 V<sub>CC</sub> unpowered

When MAX232 is unpowered, it can be safely connected to an active remote RS232 device.

#### 7.4.3 Function Tables

**Table 7-1. Each Driver**

INPUT <sup>(1)</sup>	OUTPUT
T <sub>IN</sub>	T <sub>OUT</sub>
L	H
H	L

(1) H = high level, L = low level, X = irrelevant, Z = high impedance

Table 7-2. Each Receiver

INPUTS <sup>(1)</sup>	OUTPUT
R <sub>IN</sub>	R <sub>OUT</sub>
L	H
H	L
Open	H

(1) H = high level, L = low level, X = irrelevant, Z = high impedance (off), Open = disconnected input or connected driver off

## 8 Application and Implementation

### Note

Information in the following applications sections is not part of the TI component specification, and TI does not warrant its accuracy or completeness. TI's customers are responsible for determining suitability of components for their purposes, as well as validating and testing their design implementation to confirm system functionality.

### 8.1 Application Information

For proper operation add capacitors as shown in [Figure 8-1](#). Pins 9 through 12 connect to UART or general purpose logic lines. EIA-232 lines will connect to a connector or cable.

### 8.2 Typical Application

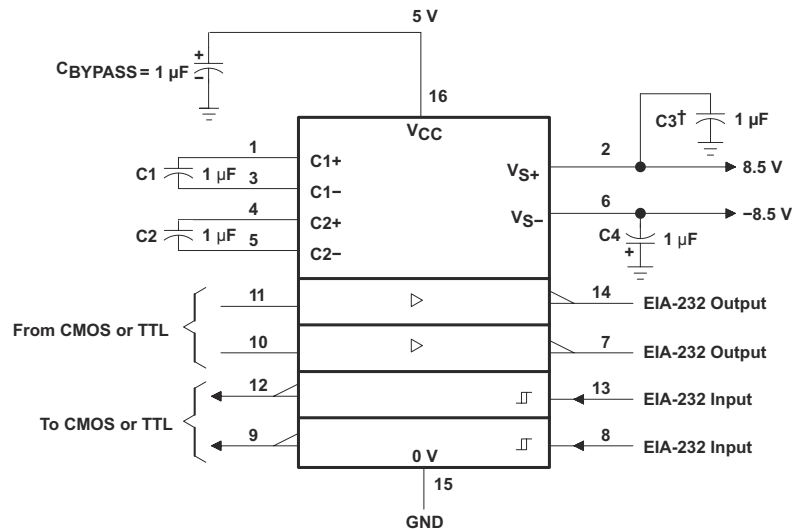

† C3 can be connected to V<sub>CC</sub> or GND.

NOTES: A. Resistor values shown are nominal.

B. Nonpolarized ceramic capacitors are acceptable. If polarized tantalum or electrolytic capacitors are used, they should be connected as shown. In addition to the 1-µF capacitors shown, the MAX202 can operate with 0.1-µF capacitors.

Figure 8-1. Typical Operating Circuit

#### 8.2.1 Design Requirements

- V<sub>CC</sub> minimum is 4.5V and maximum is 5.5V.
- Maximum recommended bit rate is 120kbps.

#### 8.2.2 Detailed Design Procedure

Use 1µF tantalum or ceramic capacitors.

### 8.2.3 Application Curves

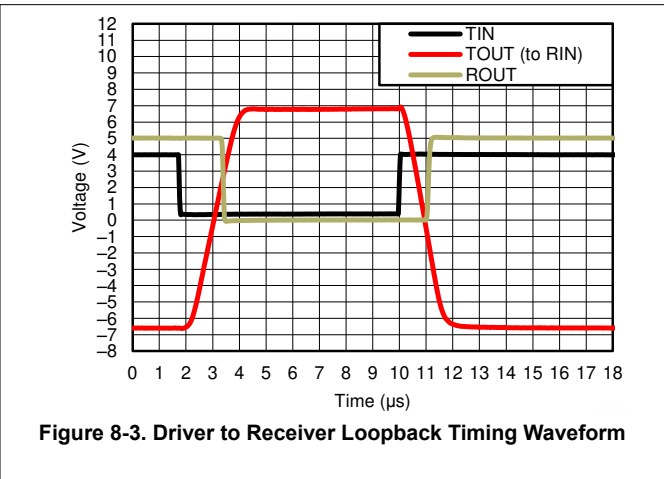
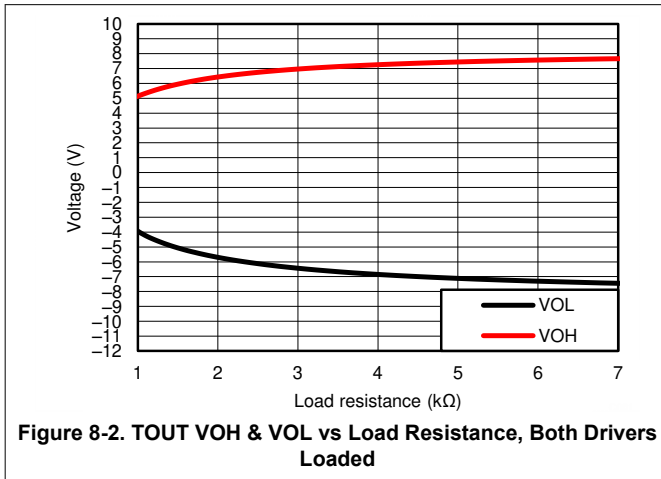

### 8.3 Power Supply Recommendations

The  $V_{CC}$  voltage should be connected to the same power source used for logic device connected to TIN pins.  $V_{CC}$  should be between 4.5V and 5.5V.

### 8.4 Layout

#### 8.4.1 Layout Guidelines

Keep the external capacitor traces short. This is more important on C1 and C2 nodes that have the fastest rise and fall times.

#### 8.4.2 Layout Example

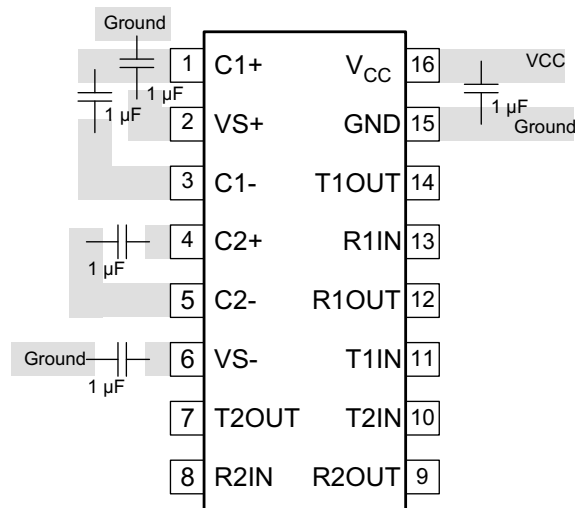

## 9 Device and Documentation Support

### 9.1 Receiving Notification of Documentation Updates

To receive notification of documentation updates, navigate to the device product folder on ti.com. In the upper right corner, click on *Alert me* to register and receive a weekly digest of any product information that has changed. For change details, review the revision history included in any revised document.

### 9.2 Support Resources

TI E2E™ [support forums](#) are an engineer's go-to source for fast, verified answers and design help — straight from the experts. Search existing answers or ask your own question to get the quick design help you need.

Linked content is provided "AS IS" by the respective contributors. They do not constitute TI specifications and do not necessarily reflect TI's views; see TI's [Terms of Use](#).

### 9.3 Trademarks

TI E2E™ is a trademark of Texas Instruments.

All trademarks are the property of their respective owners.

### 9.4 Electrostatic Discharge Caution



This integrated circuit can be damaged by ESD. Texas Instruments recommends that all integrated circuits be handled with appropriate precautions. Failure to observe proper handling and installation procedures can cause damage.

ESD damage can range from subtle performance degradation to complete device failure. Precision integrated circuits may be more susceptible to damage because very small parametric changes could cause the device not to meet its published specifications.

### 9.5 Glossary

[TI Glossary](#) This glossary lists and explains terms, acronyms, and definitions.

## 10 Revision History

### Changes from Revision M (November 2004) to Revision N (February 2024) Page

- Changed the Handling Ratings table to the *ESD Ratings* table..... 4
- Changed the *Thermal Information* table..... 4

### Changes from Revision L (March 2004) to Revision M (November 2014) Page

- Removed Ordering Information table..... 1
- Added Handling Rating table, Feature Description section, Device Functional Modes, Application and Implementation section, Power Supply Recommendations section, Layout section, Device and Documentation Support section, and Mechanical, Packaging, and Orderable Information section..... 1
- Changed the Device Information table to the *Package Information* table..... 1
- Moved  $T_{stg}$  to Handling Ratings table..... 4

## 11 Mechanical, Packaging, and Orderable Information

The following pages include mechanical packaging and orderable information. This information is the most current data available for the designated devices. This data is subject to change without notice and revision of this document. For browser based versions of this data sheet, refer to the left hand navigation.

**PACKAGING INFORMATION**

Orderable Device	Status (1)	Package Type	Package Drawing	Pins	Package Qty	Eco Plan (2)	Lead finish/ Ball material (6)	MSL Peak Temp (3)	Op Temp (°C)	Device Marking (4/5)	Samples
MAX232DR	ACTIVE	SOIC	D	16	2500	RoHS & Green	NIPDAU   SN	Level-1-260C-UNLIM	0 to 70	MAX232	<a href="#">Samples</a>
MAX232ID	LIFEBUY	SOIC	D	16	40	RoHS & Green	NIPDAU	Level-1-260C-UNLIM	-40 to 85	MAX232I	
MAX232IDG4	LIFEBUY	SOIC	D	16	40	RoHS & Green	NIPDAU	Level-1-260C-UNLIM	-40 to 85	MAX232I	
MAX232IDR	ACTIVE	SOIC	D	16	2500	RoHS & Green	NIPDAU	Level-1-260C-UNLIM	-40 to 85	MAX232I	<a href="#">Samples</a>
MAX232IDW	LIFEBUY	SOIC	DW	16	40	RoHS & Green	NIPDAU	Level-1-260C-UNLIM	-40 to 85	MAX232I	
MAX232IDWG4	LIFEBUY	SOIC	DW	16	40	RoHS & Green	NIPDAU	Level-1-260C-UNLIM	-40 to 85	MAX232I	
MAX232IDWR	ACTIVE	SOIC	DW	16	2000	RoHS & Green	NIPDAU	Level-1-260C-UNLIM	-40 to 85	MAX232I	<a href="#">Samples</a>
MAX232N	ACTIVE	PDIP	N	16	25	RoHS & Green	NIPDAU	N / A for Pkg Type	0 to 70	MAX232N	<a href="#">Samples</a>
MAX232NE4	ACTIVE	PDIP	N	16	25	RoHS & Green	NIPDAU	N / A for Pkg Type	0 to 70	MAX232N	<a href="#">Samples</a>
MAX232NSR	ACTIVE	SO	NS	16	2000	RoHS & Green	NIPDAU	Level-1-260C-UNLIM	0 to 70	MAX232	<a href="#">Samples</a>

(1) The marketing status values are defined as follows:

**ACTIVE:** Product device recommended for new designs.

**LIFEBUY:** TI has announced that the device will be discontinued, and a lifetime-buy period is in effect.

**NRND:** Not recommended for new designs. Device is in production to support existing customers, but TI does not recommend using this part in a new design.

**PREVIEW:** Device has been announced but is not in production. Samples may or may not be available.

**OBSOLETE:** TI has discontinued the production of the device.

(2) **RoHS:** TI defines "RoHS" to mean semiconductor products that are compliant with the current EU RoHS requirements for all 10 RoHS substances, including the requirement that RoHS substance do not exceed 0.1% by weight in homogeneous materials. Where designed to be soldered at high temperatures, "RoHS" products are suitable for use in specified lead-free processes. TI may reference these types of products as "Pb-Free".

**RoHS Exempt:** TI defines "RoHS Exempt" to mean products that contain lead but are compliant with EU RoHS pursuant to a specific EU RoHS exemption.

**Green:** TI defines "Green" to mean the content of Chlorine (Cl) and Bromine (Br) based flame retardants meet JS709B low halogen requirements of <=1000ppm threshold. Antimony trioxide based flame retardants must also meet the <=1000ppm threshold requirement.

(3) MSL, Peak Temp. - The Moisture Sensitivity Level rating according to the JEDEC industry standard classifications, and peak solder temperature.

(4) There may be additional marking, which relates to the logo, the lot trace code information, or the environmental category on the device.

<sup>(5)</sup> Multiple Device Markings will be inside parentheses. Only one Device Marking contained in parentheses and separated by a "~" will appear on a device. If a line is indented then it is a continuation of the previous line and the two combined represent the entire Device Marking for that device.

<sup>(6)</sup> Lead finish/Ball material - Orderable Devices may have multiple material finish options. Finish options are separated by a vertical ruled line. Lead finish/Ball material values may wrap to two lines if the finish value exceeds the maximum column width.

**Important Information and Disclaimer:**The information provided on this page represents TI's knowledge and belief as of the date that it is provided. TI bases its knowledge and belief on information provided by third parties, and makes no representation or warranty as to the accuracy of such information. Efforts are underway to better integrate information from third parties. TI has taken and continues to take reasonable steps to provide representative and accurate information but may not have conducted destructive testing or chemical analysis on incoming materials and chemicals. TI and TI suppliers consider certain information to be proprietary, and thus CAS numbers and other limited information may not be available for release.

In no event shall TI's liability arising out of such information exceed the total purchase price of the TI part(s) at issue in this document sold by TI to Customer on an annual basis.

**TAPE AND REEL INFORMATION**

**QUADRANT ASSIGNMENTS FOR PIN 1 ORIENTATION IN TAPE**

\*All dimensions are nominal

Device	Package Type	Package Drawing	Pins	SPQ	Reel Diameter (mm)	Reel Width W1 (mm)	A0 (mm)	B0 (mm)	K0 (mm)	P1 (mm)	W (mm)	Pin1 Quadrant
MAX232DR	SOIC	D	16	2500	330.0	16.4	6.5	10.3	2.1	8.0	16.0	Q1
MAX232DR	SOIC	D	16	2500	330.0	16.4	6.5	10.3	2.1	8.0	16.0	Q1
MAX232IDR	SOIC	D	16	2500	330.0	16.4	6.5	10.3	2.1	8.0	16.0	Q1
MAX232IDWR	SOIC	DW	16	2000	330.0	16.4	10.75	10.7	2.7	12.0	16.0	Q1
MAX232NSR	SO	NS	16	2000	330.0	16.4	8.2	10.5	2.5	12.0	16.0	Q1

**TAPE AND REEL BOX DIMENSIONS**

\*All dimensions are nominal

Device	Package Type	Package Drawing	Pins	SPQ	Length (mm)	Width (mm)	Height (mm)
MAX232DR	SOIC	D	16	2500	356.0	356.0	35.0
MAX232DR	SOIC	D	16	2500	333.2	345.9	28.6
MAX232IDR	SOIC	D	16	2500	340.5	336.1	32.0
MAX232IDWR	SOIC	DW	16	2000	350.0	350.0	43.0
MAX232NSR	SO	NS	16	2000	367.0	367.0	38.0

**TUBE**

\*All dimensions are nominal

Device	Package Name	Package Type	Pins	SPQ	L (mm)	W (mm)	T (μm)	B (mm)
MAX232ID	D	SOIC	16	40	507	8	3940	4.32
MAX232IDG4	D	SOIC	16	40	507	8	3940	4.32
MAX232IDW	DW	SOIC	16	40	506.98	12.7	4826	6.6
MAX232IDWG4	DW	SOIC	16	40	506.98	12.7	4826	6.6
MAX232N	N	PDIP	16	25	506	13.97	11230	4.32
MAX232N	N	PDIP	16	25	506	13.97	11230	4.32
MAX232NE4	N	PDIP	16	25	506	13.97	11230	4.32
MAX232NE4	N	PDIP	16	25	506	13.97	11230	4.32



# PACKAGE OUTLINE

## NS0016A

### SOP - 2.00 mm max height

SOP



4220735/A 12/2021

#### NOTES:

1. All linear dimensions are in millimeters. Dimensions in parenthesis are for reference only. Dimensioning and tolerancing per ASME Y14.5M.
2. This drawing is subject to change without notice.
3. This dimension does not include mold flash, protrusions, or gate burrs. Mold flash, protrusions, or gate burrs shall not exceed 0.15 mm, per side.
4. This dimension does not include interlead flash. Interlead flash shall not exceed 0.25 mm, per side.

# EXAMPLE BOARD LAYOUT

NS0016A

SOP - 2.00 mm max height

SOP

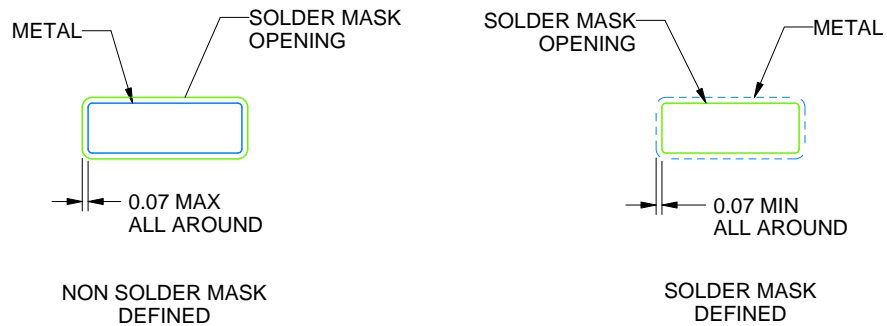

4220735/A 12/2021

NOTES: (continued)

5. Publication IPC-7351 may have alternate designs.

6. Solder mask tolerances between and around signal pads can vary based on board fabrication site.

# EXAMPLE STENCIL DESIGN

NS0016A

SOP - 2.00 mm max height

SOP

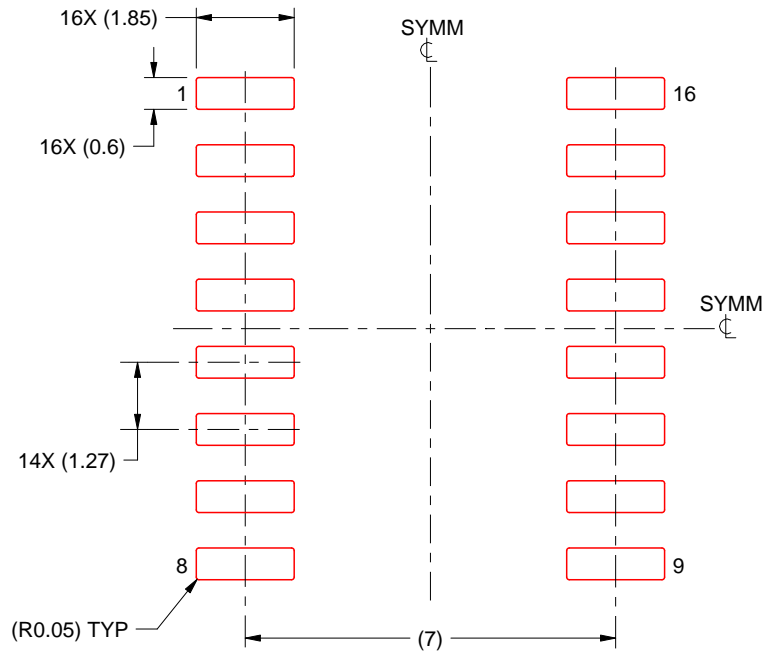

SOLDER PASTE EXAMPLE  
BASED ON 0.125 mm THICK STENCIL  
SCALE:7X

4220735/A 12/2021

NOTES: (continued)

7. Laser cutting apertures with trapezoidal walls and rounded corners may offer better paste release. IPC-7525 may have alternate design recommendations.
8. Board assembly site may have different recommendations for stencil design.

D (R-PDSO-G16)

PLASTIC SMALL OUTLINE



- NOTES:
- A. All linear dimensions are in inches (millimeters).
  - B. This drawing is subject to change without notice.
  - C. Body length does not include mold flash, protrusions, or gate burrs. Mold flash, protrusions, or gate burrs shall not exceed 0.006 (0,15) each side.
  - D. Body width does not include interlead flash. Interlead flash shall not exceed 0.017 (0,43) each side.
  - E. Reference JEDEC MS-012 variation AC.

D (R-PDSO-G16)

PLASTIC SMALL OUTLINE

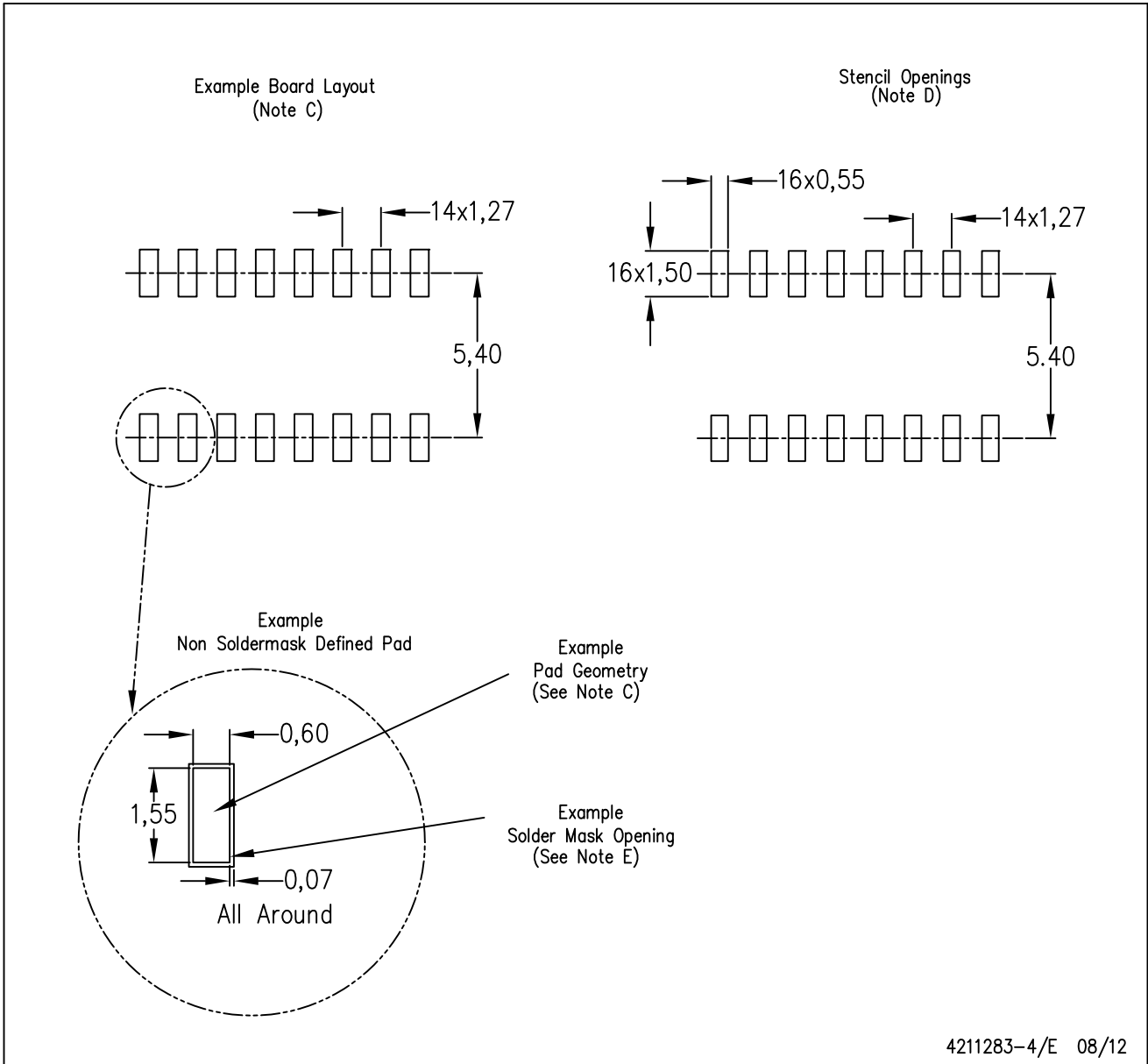

- NOTES:
- All linear dimensions are in millimeters.
  - This drawing is subject to change without notice.
  - Publication IPC-7351 is recommended for alternate designs.
  - Laser cutting apertures with trapezoidal walls and also rounding corners will offer better paste release. Customers should contact their board assembly site for stencil design recommendations. Refer to IPC-7525 for other stencil recommendations.
  - Customers should contact their board fabrication site for solder mask tolerances between and around signal pads.

# MECHANICAL DATA

NS (R-PDSO-G\*\*)

PLASTIC SMALL-OUTLINE PACKAGE

14-PINS SHOWN



- NOTES:
- A. All linear dimensions are in millimeters.
  - B. This drawing is subject to change without notice.
  - C. Body dimensions do not include mold flash or protrusion, not to exceed 0,15.

## GENERIC PACKAGE VIEW

**DW 16**

**SOIC - 2.65 mm max height**

7.5 x 10.3, 1.27 mm pitch

SMALL OUTLINE INTEGRATED CIRCUIT

This image is a representation of the package family, actual package may vary.  
Refer to the product data sheet for package details.

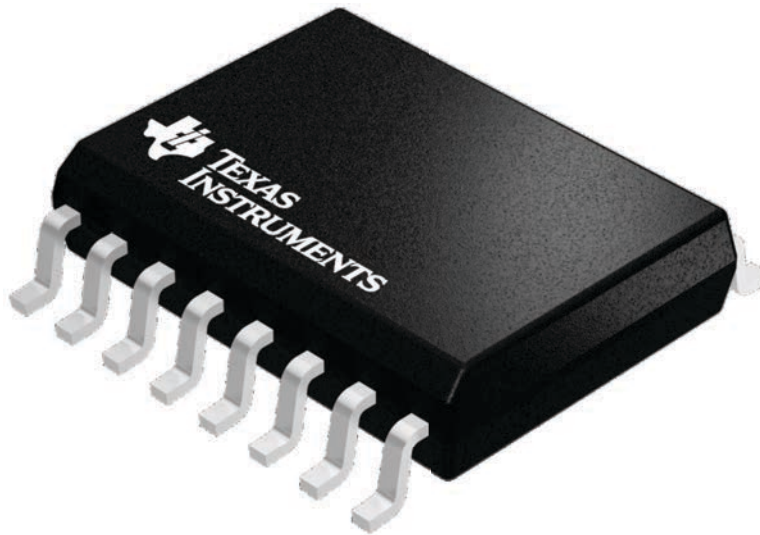

4224780/A



DW0016A

# PACKAGE OUTLINE

SOIC - 2.65 mm max height

SOIC



4220721/A 07/2016

NOTES:

1. All linear dimensions are in millimeters. Dimensions in parenthesis are for reference only. Dimensioning and tolerancing per ASME Y14.5M.
2. This drawing is subject to change without notice.
3. This dimension does not include mold flash, protrusions, or gate burrs. Mold flash, protrusions, or gate burrs shall not exceed 0.15 mm, per side.
4. This dimension does not include interlead flash. Interlead flash shall not exceed 0.25 mm, per side.
5. Reference JEDEC registration MS-013.

# EXAMPLE BOARD LAYOUT

DW0016A

SOIC - 2.65 mm max height

SOIC

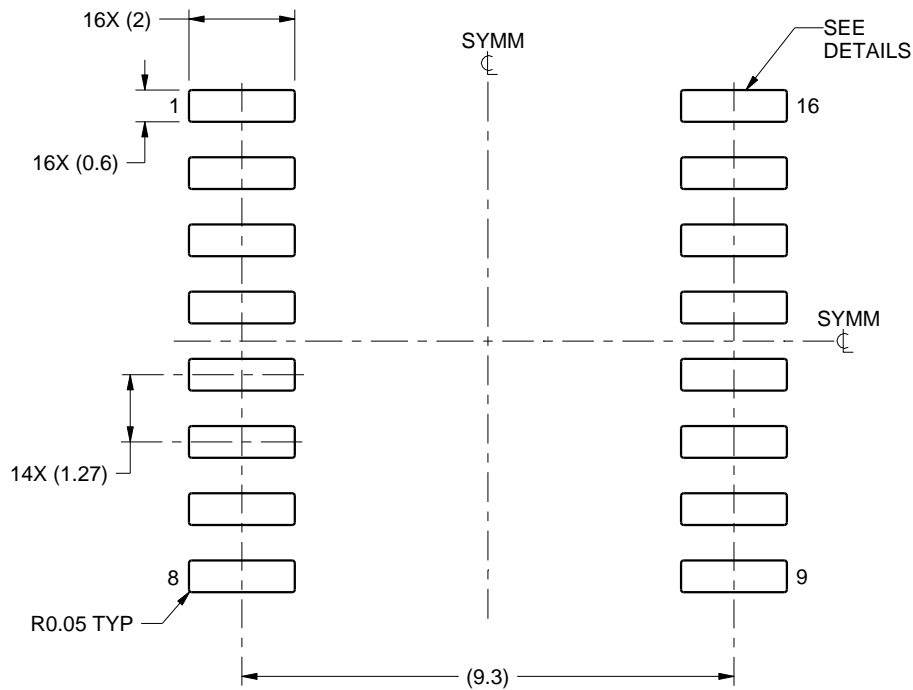

LAND PATTERN EXAMPLE  
SCALE:7X



SOLDER MASK DETAILS

4220721/A 07/2016

NOTES: (continued)

- 6. Publication IPC-7351 may have alternate designs.
- 7. Solder mask tolerances between and around signal pads can vary based on board fabrication site.

# EXAMPLE STENCIL DESIGN

DW0016A

SOIC - 2.65 mm max height

SOIC



SOLDER PASTE EXAMPLE  
BASED ON 0.125 mm THICK STENCIL  
SCALE:7X

4220721/A 07/2016

NOTES: (continued)

8. Laser cutting apertures with trapezoidal walls and rounded corners may offer better paste release. IPC-7525 may have alternate design recommendations.
9. Board assembly site may have different recommendations for stencil design.

N (R-PDIP-T\*\*)

PLASTIC DUAL-IN-LINE PACKAGE

16 PINS SHOWN



4040049/E 12/2002

- NOTES:
- A. All linear dimensions are in inches (millimeters).
  - B. This drawing is subject to change without notice.
  - C Falls within JEDEC MS-001, except 18 and 20 pin minimum body length (Dim A).
  - D The 20 pin end lead shoulder width is a vendor option, either half or full width.

## IMPORTANT NOTICE AND DISCLAIMER

TI PROVIDES TECHNICAL AND RELIABILITY DATA (INCLUDING DATA SHEETS), DESIGN RESOURCES (INCLUDING REFERENCE DESIGNS), APPLICATION OR OTHER DESIGN ADVICE, WEB TOOLS, SAFETY INFORMATION, AND OTHER RESOURCES "AS IS" AND WITH ALL FAULTS, AND DISCLAIMS ALL WARRANTIES, EXPRESS AND IMPLIED, INCLUDING WITHOUT LIMITATION ANY IMPLIED WARRANTIES OF MERCHANTABILITY, FITNESS FOR A PARTICULAR PURPOSE OR NON-INFRINGEMENT OF THIRD PARTY INTELLECTUAL PROPERTY RIGHTS.

These resources are intended for skilled developers designing with TI products. You are solely responsible for (1) selecting the appropriate TI products for your application, (2) designing, validating and testing your application, and (3) ensuring your application meets applicable standards, and any other safety, security, regulatory or other requirements.

These resources are subject to change without notice. TI grants you permission to use these resources only for development of an application that uses the TI products described in the resource. Other reproduction and display of these resources is prohibited. No license is granted to any other TI intellectual property right or to any third party intellectual property right. TI disclaims responsibility for, and you will fully indemnify TI and its representatives against, any claims, damages, costs, losses, and liabilities arising out of your use of these resources.

TI's products are provided subject to [TI's Terms of Sale](#) or other applicable terms available either on [ti.com](https://www.ti.com) or provided in conjunction with such TI products. TI's provision of these resources does not expand or otherwise alter TI's applicable warranties or warranty disclaimers for TI products.

TI objects to and rejects any additional or different terms you may have proposed.

Mailing Address: Texas Instruments, Post Office Box 655303, Dallas, Texas 75265  
Copyright © 2024, Texas Instruments Incorporated

## Looking for pricing, stock, or lifecycle information?

Click below to explore more details on WIN SOURCE:

 [View MAX232N](#) on WIN SOURCE

 [Texas Instruments](#) Information

## Optimize Your Supply Chain with WIN SOURCE Solutions

-  Global Sourcing Solution
-  Obsolete Management
-  Cost Control Management
-  Shortage Management
-  Alternative Solution
-  Excess Inventory Management