



THE DATASHEET OF MAX213IDBR



FEATURES

- ESD Protection for RS-232 Bus Pins
– ± 15 -kV Human-Body Model (HBM)
- Meets or Exceeds the Requirements of TIA/EIA-232-F and ITU v.28 Standards
- Operates at 5-V V_{CC} Supply
- Four Drivers and Five Receivers
- Operates up to 120 kbit/s
- Low Supply Current in Shutdown Mode . . . 15 μ A Typ
- External Capacitors . . . 4×0.1 F
- Designed to Be Interchangeable With Maxim MAX213
- Latch-Up Performance Exceeds 100 mA Per JESD 78, Class II

DB, DW, OR PW PACKAGE
(TOP VIEW)

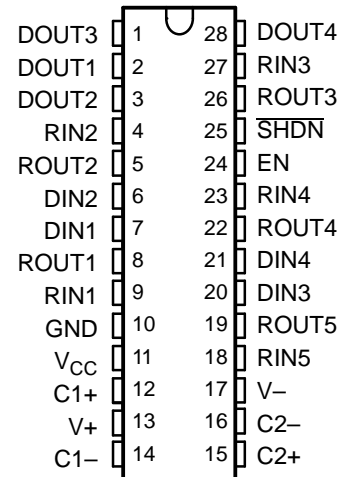

APPLICATIONS

- Battery-Powered Systems
- PDAs
- Notebooks
- Laptops
- Palmtop PCs
- Hand-Held Equipment

DESCRIPTION/ ORDER INFORMATION

The MAX213 device consists of four line drivers, five line receivers, and a dual charge-pump circuit with ± 15 -kV ESD protection pin to pin (serial-port connection pins, including GND). The device meets the requirements of TIA/EIA-232-F and provides the electrical interface between an asynchronous communication controller and the serial-port connector. The charge pump and four small external capacitors allow operation from a single 5-V supply. The devices operate at data signaling rates up to 120 kbit/s and a maximum of 30-V/ μ s driver output slew rate.

The MAX213 has an active-low shutdown ($\overline{\text{SHDN}}$) and an active-high enable control (EN). In shutdown mode, the charge pumps are turned off, V+ is pulled down to V_{CC} , V- is pulled to GND, and the transmitter outputs are disabled. This reduces supply current typically to 1 μ A. Two receivers of the MAX213 are active during shutdown.



Please be aware that an important notice concerning availability, standard warranty, and use in critical applications of Texas Instruments semiconductor products and disclaimers thereto appears at the end of this data sheet.

MAX213
5-V MULTICHANNEL RS-232 LINE DRIVER/RECEIVER
WITH ± 15 -kV ESD PROTECTION

SLLS680–DECEMBER 2005

ORDERING INFORMATION

T_A	PACKAGE ⁽¹⁾		ORDERABLE PART NUMBER	TOP-SIDE MARKING
0°C to 70°C	SOIC – DW	Tube of 20	MAX213CDW	
		Reel of 1000	MAX213CDWR	
	SSOP – DB	Tube of 50	MAX213CDB	
		Reel of 2000	MAX213CDBR	
	TSSOP – PW	Tape and reel	MAX213CPWR	
	–40°C to 85°C	SOIC – DW	Tube of 20	
Reel of 1000			MAX213IDWR	
SSOP – DB		Tube of 50	MAX213IDB	
		Reel of 2000	MAX213IDBR	
TSSOP – PW		Tape and reel	MAX213IPWR	

(1) Package drawings, standard packing quantities, thermal data, symbolization, and PCB design guidelines are available at www.ti.com/sc/package.

FUNCTION TABLE

INPUTS		DRIVER D1–D4	RECEIVER		DEVICE STATUS
$\overline{\text{SHDN}}$	EN		R1–R3	R4–R5	
L	L	Z	Z	Z	Shutdown
L	H	Z	Z	Active ⁽¹⁾	Shutdown
H	L	All active	Z	Z	Normal operation
H	H	All active	Active	Active	Normal operation

(1) See the V_{IT+} and V_{IT-} change in the *Electrical Characteristics* table.

LOGIC DIAGRAM (POSITIVE LOGIC)

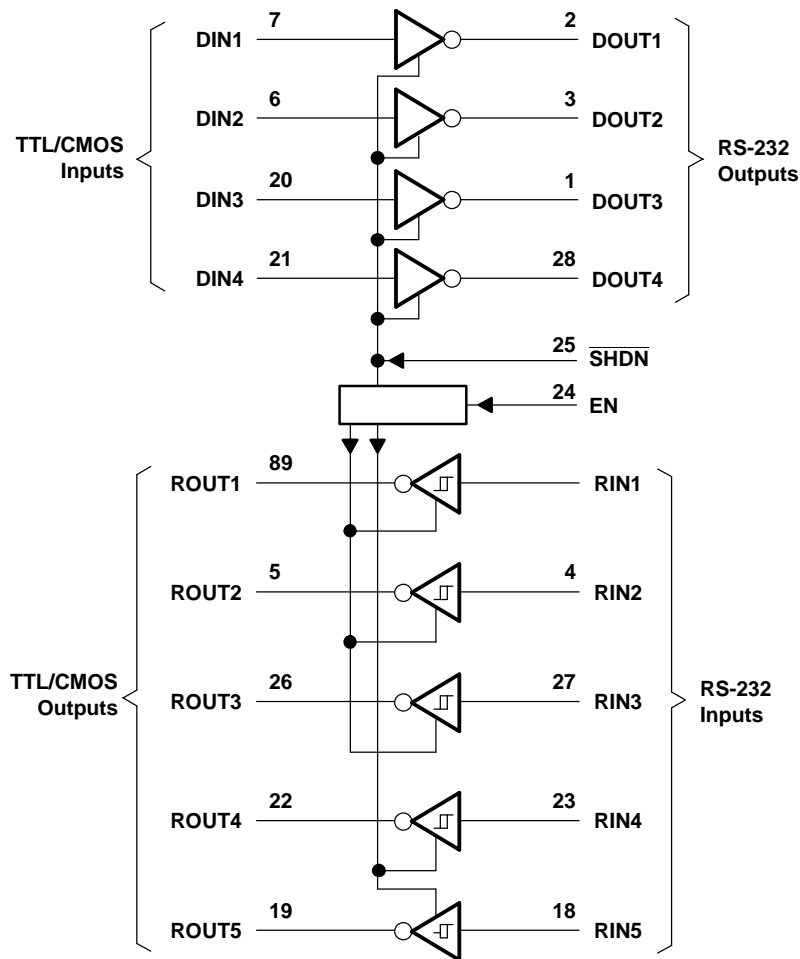

MAX213

5-V MULTICHANNEL RS-232 LINE DRIVER/RECEIVER

WITH ± 15 -kV ESD PROTECTION

SLLS680–DECEMBER 2005

Absolute Maximum Ratings⁽¹⁾

over operating free-air temperature range (unless otherwise noted)

		MIN	MAX	UNIT
V _{CC}	Supply voltage range	-0.3	6	V
V+	Positive charge-pump voltage range ⁽²⁾	V _{CC} - 0.3	14	V
V-	Negative charge-pump voltage range ⁽²⁾	0.3	-14	V
V _I	Input voltage range	Drivers	V+ + 0.3	V
		Receivers	±30	
V _O	Output voltage range	Drivers	V- - 0.3	V
		Receivers	-0.3	
DOUT	Short-circuit duration	Continuous		
θ _{JA}	Package thermal impedance ⁽³⁾⁽⁴⁾	DB package	62	C°/W
		DW package	46	
		PW package		
T _J	Operating virtual junction temperature		150	C°
T _{stg}	Storage temperature range	-65	150	C°

- (1) Stresses beyond those listed under "absolute maximum ratings" may cause permanent damage to the device. These are stress ratings only, and functional operation of the device at these or any other conditions beyond those indicated under "recommended operating conditions" is not implied. Exposure to absolute-maximum-rated conditions for extended periods may affect device reliability.
- (2) All voltages are with respect to network GND.
- (3) Maximum power dissipation is a function of T_J(max), θ_{JA}, and T_A. The maximum allowable power dissipation at any allowable ambient temperature is P_D = (T_J(max) - T_A)/θ_{JA}. Operating at the absolute maximum T_J of 150°C can affect reliability.
- (4) The package thermal impedance is calculated in accordance with JESD 51-7.

Recommended Operating Conditions⁽¹⁾

See [Figure 4](#)

			MIN	NOM	MAX	UNIT
Supply voltage			4.5	5	5.5	V
V _{IH}	Driver high-level input voltage	DIN	2			V
	Control high-level input voltage	EN, $\overline{\text{SHDN}}$	2.4			
V _{IL}	Driver and control low-level input voltage	DIN, EN, $\overline{\text{SHDN}}$			0.8	V
V _I	Driver and control input voltage	DIN, EN, $\overline{\text{SHDN}}$	0		5.5	V
	Receiver input voltage	RIN	-30		30	
T _A	Operating free-air temperature	MAX213C	0		70	°C
		MAX213I	-40		85	

- (1) Test conditions are C1–C4 = 0.1 μF at V_{CC} = 5 V ± 0.5 V.

Electrical Characteristics⁽¹⁾

over operating free-air temperature range (unless otherwise noted)

PARAMETER	TEST CONDITIONS	MIN	TYP ⁽²⁾	MAX	UNIT
I _{CC}	Supply current No load, See Figure 6		14	20	mA
I _{SHDN}	Shutdown supply current T _A = 25°C, See Figure 1		15	50	μA

- (1) Test conditions are C1–C4 = 0.1 μF at V_{CC} = 5 V ± 0.5 V.
- (2) All typical values are at V_{CC} = 5 V, and T_A = 25°C.

DRIVER SECTION

Electrical Characteristics⁽¹⁾

over operating free-air temperature range (unless otherwise noted) (see Figure 4)

PARAMETER		TEST CONDITIONS	MIN	TYP ⁽²⁾	MAX	UNIT
V _{OH}	High-level output voltage	DOUT at R _L = 3 kΩ to GND	5	9		V
V _{OL}	Low-level output voltage	DOUT at R _L = 3 kΩ to GND	–5	–9		V
I _{IH}	Control high-level input current	EN, $\overline{\text{SHDN}} = 5\text{ V}$		3	10	μA
I _{IL}	Driver low-level input current	DIN = 0 V		–15	–200	μA
	Control low-level input current	EN, $\overline{\text{SHDN}} = 0\text{ V}$		–3	–10	
I _{OS} ⁽³⁾	Short-circuit output current	V _{CC} = 5.5 V, V _O = 0 V		±10	±60	mA
r _o	Output resistance	V _{CC} , V+, and V– = 0 V, V _O = ±2 V	300			Ω

(1) Test conditions are C1–C4 = 0.1 μF at V_{CC} = 5 V ± 0.5 V

(2) All typical values are at V_{CC} = 5 V, and T_A = 25°C.

(3) Short-circuit durations should be controlled to prevent exceeding the device absolute power dissipation ratings, and not more than one output should be shorted at a time.

Switching Characteristics⁽¹⁾

over operating free-air temperature range (unless otherwise noted)

PARAMETER		TEST CONDITIONS	MIN	TYP ⁽²⁾	MAX	UNIT
	Maximum data rate	C _L = 50 pF to 1000 pF, One DOUT switching, R _L = 3 kΩ to 7 kΩ, See Figure 3	120			kbit/s
t _{PLH(D)}	Propagation delay time, low- to high-level output	C _L = 2500 pF, All drivers loaded, R _L = 3 kΩ, See Figure 3		2		μs
t _{PHL(D)}	Propagation delay time, high- to low-level output	C _L = 2500 pF, All drivers loaded, R _L = 3 kΩ, See Figure 3		2		μs
t _{sk(p)}	Pulse skew ⁽³⁾	C _L = 150 pF to 2500 pF, See Figure 3, R _L = 3 kΩ to 7 kΩ,		300		ns
SR(tr)	Slew rate, transition region (see Figure 2)	C _L = 50 pF to 1000 pF, V _{CC} = 5 V, R _L = 3 kΩ to 7 kΩ,	3	6	30	V/μs

(1) Test conditions are C1–C4 = 0.1 μF at V_{CC} = 5 V ± 0.5 V.

(2) All typical values are at V_{CC} = 5 V, and T_A = 25°C.

(3) Pulse skew is defined as (t_{PLH} – t_{PHL}) of each channel of the same device.

ESD Protection

over operating free-air temperature range (unless otherwise noted)

PIN	TEST CONDITIONS	TYP	UNIT
DOUT	Human-Body Model	±15	kV

MAX213

5-V MULTICHANNEL RS-232 LINE DRIVER/RECEIVER

WITH ± 15 -kV ESD PROTECTION

SLLS680–DECEMBER 2005

RECEIVER SECTION

Electrical Characteristics⁽¹⁾

over operating free-air temperature range (unless otherwise noted) (see [Figure 6](#))

PARAMETER		TEST CONDITIONS		MIN	TYP ⁽²⁾	MAX	UNIT	
V_{OH}	High-level output voltage	$I_{OH} = -1$ mA		$V_{CC} - 0.4$			V	
V_{OL}	Low-level output voltage	$I_{OH} = 1.6$ mA		0.4			V	
V_{IT+}	Positive-going input threshold voltage	$V_{CC} = 5$ V, $T_A = 25^\circ\text{C}$	Active mode	1.7		2.4	V	
			Shutdown mode (R4–R5)	1.5		2.4		
V_{IT-}	Negative-going input threshold voltage	$V_{CC} = 5$ V, $T_A = 25^\circ\text{C}$	Active mode	0.8		1.2	V	
			Shutdown mode (R4–R5)	0.6		1.5		
V_{hys} ⁽³⁾	Input hysteresis (V_{IT+} , V_{IT-})	$V_{CC} = 5$ V		0.5		1	V	
r_i	Input resistance	$V_{CC} = 5$ V, $T_A = 25^\circ\text{C}$		3		5	7	k Ω
	Output leakage current	$EN = 0$ V, $0 \leq RO_{UT} \leq V_{CC}$, R1–R3		± 0.05		± 10	μA	

(1) Test conditions are C1–C4 = 0.1 μF at $V_{CC} = 5$ V ± 0.5 V.

(2) All typical values are at $V_{CC} = 5$ V, and $T_A = 25^\circ\text{C}$.

(3) No hysteresis in shutdown mode

Switching Characteristics⁽¹⁾

over operating free-air temperature range (unless otherwise noted)

PARAMETER		TEST CONDITIONS		MIN	TYP ⁽²⁾	MAX	UNIT	
$t_{PLH(R)}$	Propagation delay time, low- to high-level output	$C_L = 150$ pF,	See Figure 4	$\overline{\text{SHDN}} = V_{CC}$	0.5		10	μs
				$\overline{\text{SHDN}} = 0$ V, R4–R5	4		40	
$t_{PHL(R)}$	Propagation delay time, high- to low-level output	$C_L = 150$ pF,	See Figure 4	0.5		10	μs	
t_{en}	Output enable time	$C_L = 150$ pF,	See Figure 5	600			ns	
t_{dis}	Output disable time	$C_L = 150$ pF,	See Figure 5	200			ns	

(1) Test conditions are C1–C4 = 0.1 μF at $V_{CC} = 5$ V ± 0.5 V.

(2) All typical values are at $V_{CC} = 5$ V, and $T_A = 25^\circ\text{C}$.

ESD Protection

over operating free-air temperature range (unless otherwise noted)

PIN	TEST CONDITIONS	TYP	UNIT
RIN	Human-Body Model	± 15	kV

PARAMETER MEASUREMENT INFORMATION

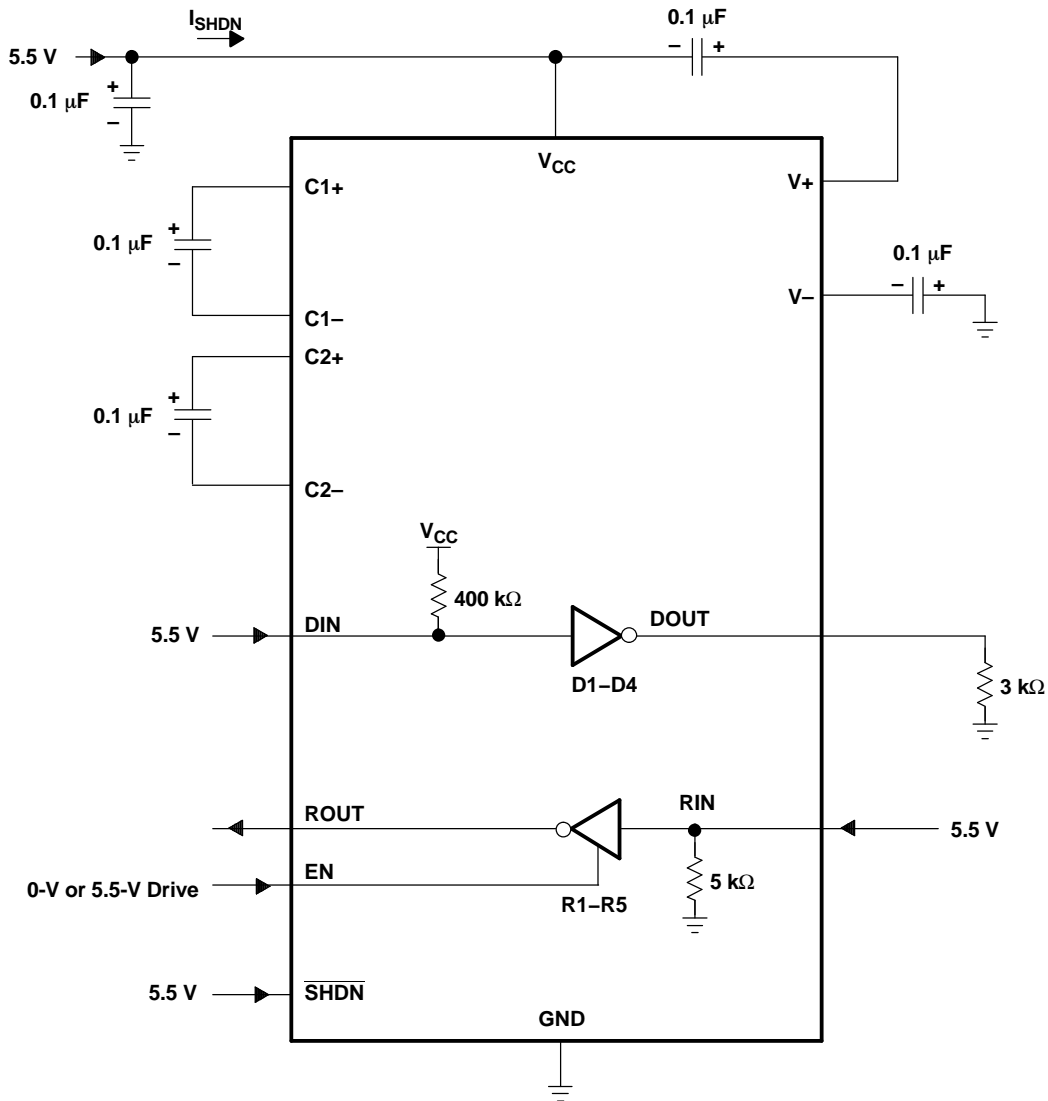
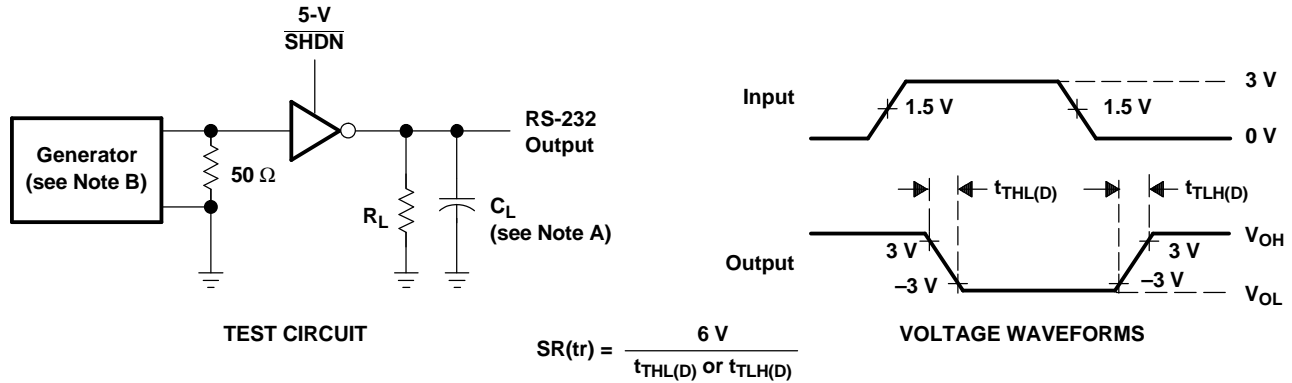

Figure 1. Shutdown Current Test Circuit

PARAMETER MEASUREMENT INFORMATION (continued)



NOTES: A. C_L includes probe and jig capacitance.
 B. The pulse generator has the following characteristics: $Z_O = 50\ \Omega$, 50% duty cycle, $t_r \leq 10\text{ ns}$, $t_f \leq 10\text{ ns}$.

Figure 2. Driver Slew Rate

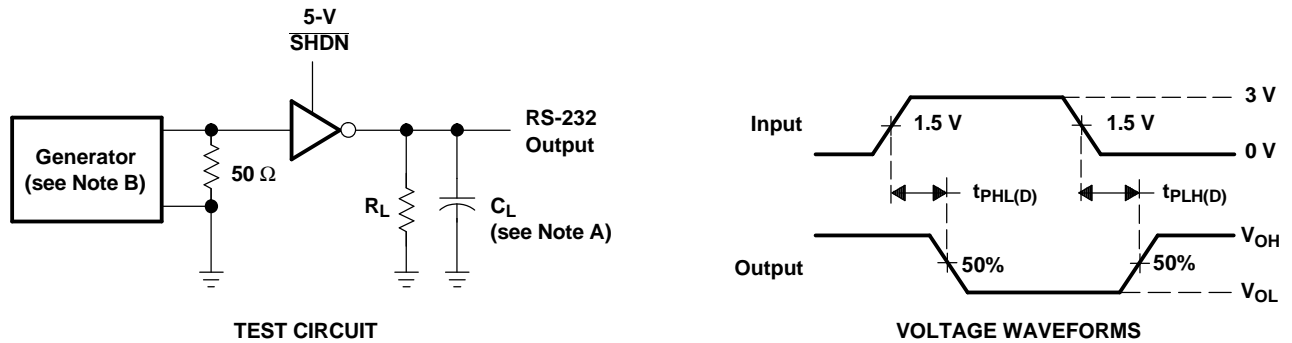

NOTES: A. C_L includes probe and jig capacitance.
 B. The pulse generator has the following characteristics: $Z_O = 50\ \Omega$, 50% duty cycle, $t_r \leq 10\text{ ns}$, $t_f \leq 10\text{ ns}$.

Figure 3. Driver Pulse Skew and Propagation Delay Times

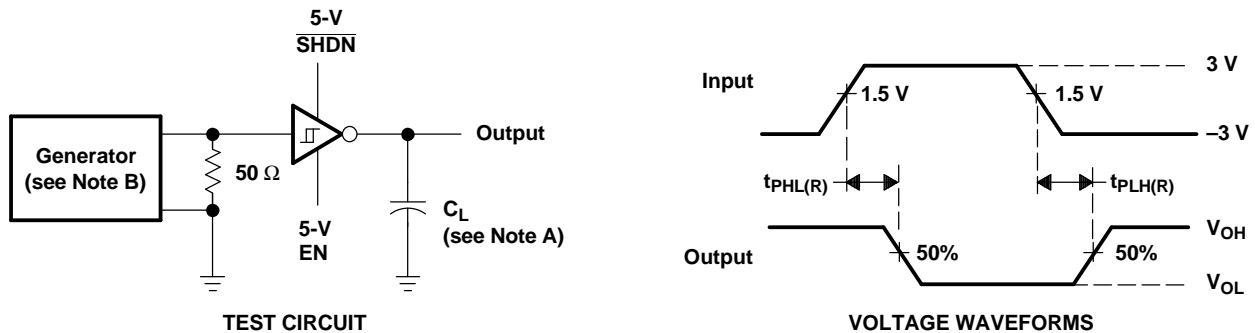

NOTES: A. C_L includes probe and jig capacitance.
 B. The pulse generator has the following characteristics: $Z_O = 50\ \Omega$, 50% duty cycle, $t_r \leq 10\text{ ns}$, $t_f \leq 10\text{ ns}$.

Figure 4. Receiver Propagation Delay Times

PARAMETER MEASUREMENT INFORMATION (continued)

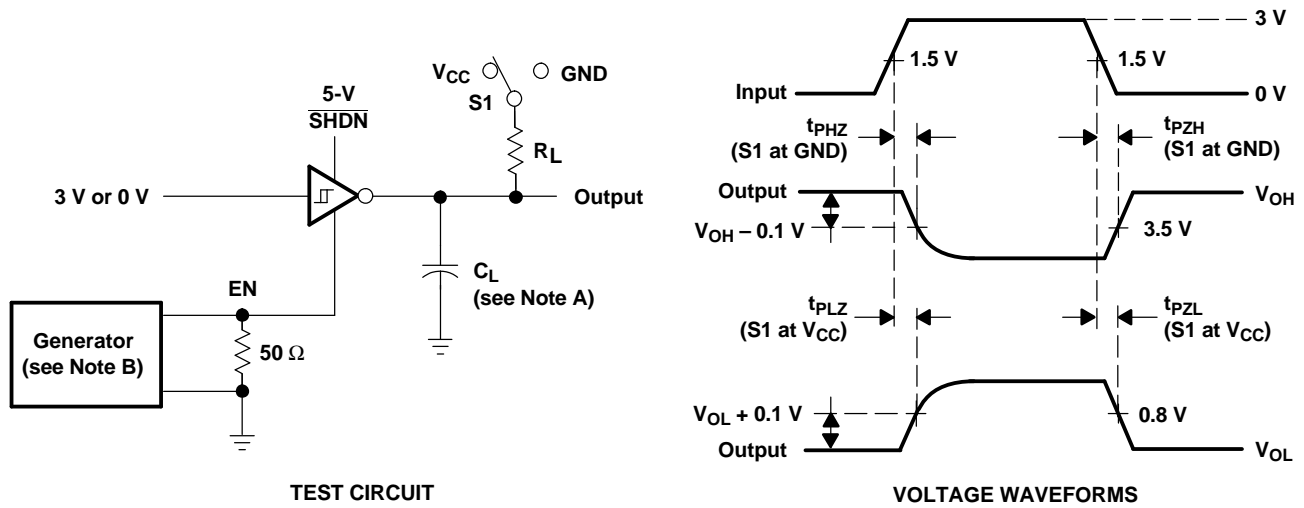

- NOTES: A. C_L includes probe and jig capacitance.
 B. The pulse generator has the following characteristics: $Z_O = 50 \Omega$, 50% duty cycle, $t_r \leq 10$ ns, $t_f \leq 10$ ns.
 C. t_{PLZ} and t_{PHZ} are the same as t_{dis} .
 D. t_{PZL} and t_{PZH} are the same as t_{en} .

Figure 5. Receiver Enable and Disable Times

APPLICATION INFORMATION

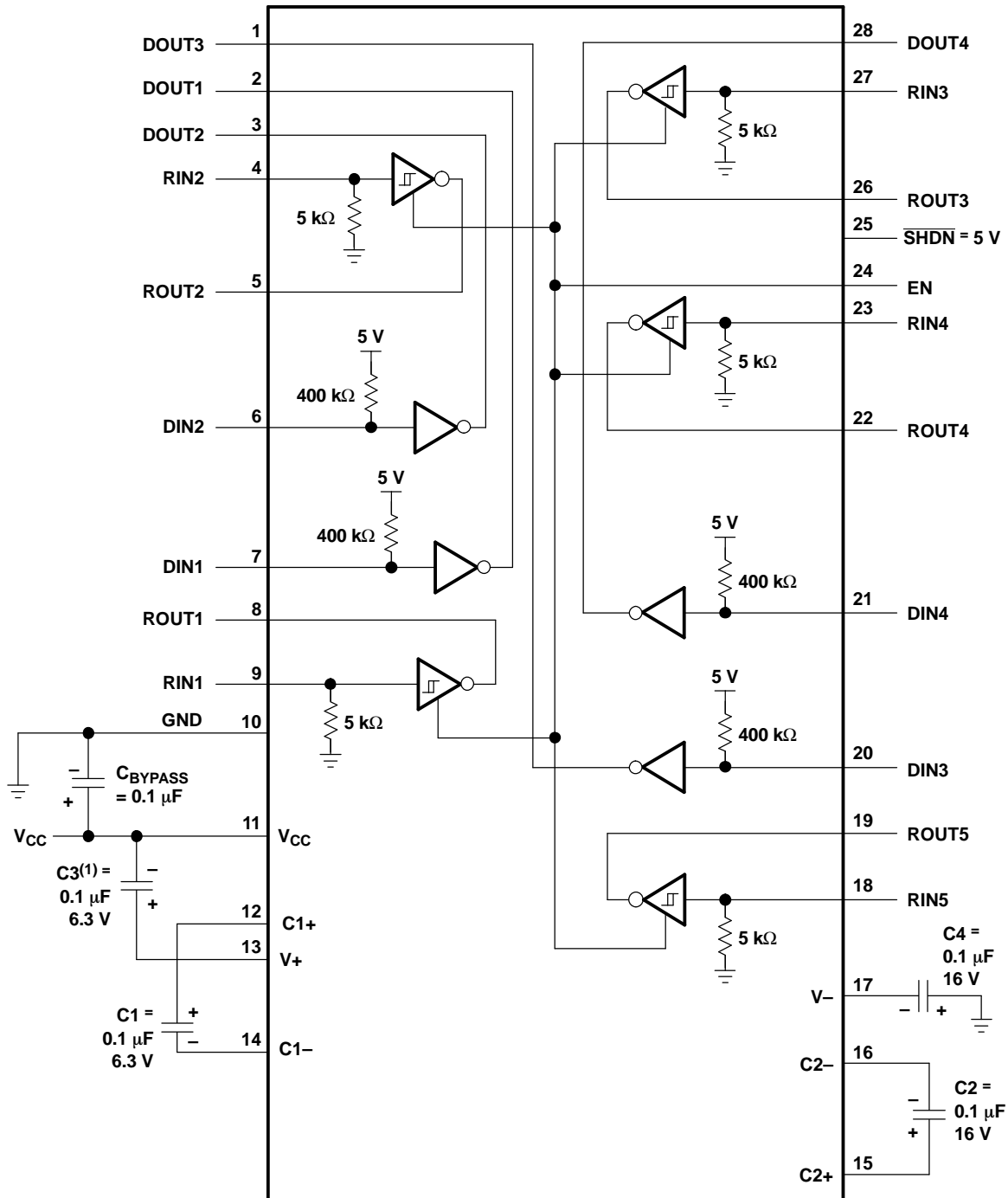

(1) C3 can be connected to V_{CC} or GND.

NOTES: A. Resistor values shown are nominal.

B. Nonpolarized ceramic capacitors are acceptable. If polarized tantalum or electrolytic capacitors are used, they should be connected as shown.

Figure 6. Typical Operating Circuit and Capacitor Values

PACKAGING INFORMATION

Orderable Device	Status (1)	Package Type	Package Drawing	Pins	Package Qty	Eco Plan (2)	Lead/Ball Finish (6)	MSL Peak Temp (3)	Op Temp (°C)	Device Marking (4/5)	Samples
MAX213CDB	ACTIVE	SSOP	DB	28	50	Green (RoHS & no Sb/Br)	CU NIPDAU	Level-1-260C-UNLIM	0 to 70	MAX213C	Samples
MAX213CDBR	ACTIVE	SSOP	DB	28	2000	Green (RoHS & no Sb/Br)	CU NIPDAU	Level-1-260C-UNLIM	0 to 70	MAX213C	Samples
MAX213CDW	ACTIVE	SOIC	DW	28	20	Green (RoHS & no Sb/Br)	CU NIPDAU	Level-1-260C-UNLIM	0 to 70	MAX213C	Samples
MAX213CDWR	ACTIVE	SOIC	DW	28	1000	Green (RoHS & no Sb/Br)	CU NIPDAU	Level-1-260C-UNLIM	0 to 70	MAX213C	Samples
MAX213IDB	ACTIVE	SSOP	DB	28	50	Green (RoHS & no Sb/Br)	CU NIPDAU	Level-1-260C-UNLIM	-40 to 85	MAX213I	Samples
MAX213IDBR	ACTIVE	SSOP	DB	28	2000	Green (RoHS & no Sb/Br)	CU NIPDAU	Level-1-260C-UNLIM	-40 to 85	MAX213I	Samples
MAX213IDWR	ACTIVE	SOIC	DW	28	1000	Green (RoHS & no Sb/Br)	CU NIPDAU	Level-1-260C-UNLIM	-40 to 85	MAX213I	Samples

(1) The marketing status values are defined as follows:

ACTIVE: Product device recommended for new designs.

LIFEBUY: TI has announced that the device will be discontinued, and a lifetime-buy period is in effect.

NRND: Not recommended for new designs. Device is in production to support existing customers, but TI does not recommend using this part in a new design.

PREVIEW: Device has been announced but is not in production. Samples may or may not be available.

OBSOLETE: TI has discontinued the production of the device.

(2) Eco Plan - The planned eco-friendly classification: Pb-Free (RoHS), Pb-Free (RoHS Exempt), or Green (RoHS & no Sb/Br) - please check <http://www.ti.com/productcontent> for the latest availability information and additional product content details.

TBD: The Pb-Free/Green conversion plan has not been defined.

Pb-Free (RoHS): TI's terms "Lead-Free" or "Pb-Free" mean semiconductor products that are compatible with the current RoHS requirements for all 6 substances, including the requirement that lead not exceed 0.1% by weight in homogeneous materials. Where designed to be soldered at high temperatures, TI Pb-Free products are suitable for use in specified lead-free processes.

Pb-Free (RoHS Exempt): This component has a RoHS exemption for either 1) lead-based flip-chip solder bumps used between the die and package, or 2) lead-based die adhesive used between the die and leadframe. The component is otherwise considered Pb-Free (RoHS compatible) as defined above.

Green (RoHS & no Sb/Br): TI defines "Green" to mean Pb-Free (RoHS compatible), and free of Bromine (Br) and Antimony (Sb) based flame retardants (Br or Sb do not exceed 0.1% by weight in homogeneous material)

(3) MSL, Peak Temp. - The Moisture Sensitivity Level rating according to the JEDEC industry standard classifications, and peak solder temperature.

(4) There may be additional marking, which relates to the logo, the lot trace code information, or the environmental category on the device.

⁽⁵⁾ Multiple Device Markings will be inside parentheses. Only one Device Marking contained in parentheses and separated by a "-" will appear on a device. If a line is indented then it is a continuation of the previous line and the two combined represent the entire Device Marking for that device.

⁽⁶⁾ Lead/Ball Finish - Orderable Devices may have multiple material finish options. Finish options are separated by a vertical ruled line. Lead/Ball Finish values may wrap to two lines if the finish value exceeds the maximum column width.

Important Information and Disclaimer:The information provided on this page represents TI's knowledge and belief as of the date that it is provided. TI bases its knowledge and belief on information provided by third parties, and makes no representation or warranty as to the accuracy of such information. Efforts are underway to better integrate information from third parties. TI has taken and continues to take reasonable steps to provide representative and accurate information but may not have conducted destructive testing or chemical analysis on incoming materials and chemicals. TI and TI suppliers consider certain information to be proprietary, and thus CAS numbers and other limited information may not be available for release.

In no event shall TI's liability arising out of such information exceed the total purchase price of the TI part(s) at issue in this document sold by TI to Customer on an annual basis.

TAPE AND REEL INFORMATION



QUADRANT ASSIGNMENTS FOR PIN 1 ORIENTATION IN TAPE



*All dimensions are nominal

Device	Package Type	Package Drawing	Pins	SPQ	Reel Diameter (mm)	Reel Width W1 (mm)	A0 (mm)	B0 (mm)	K0 (mm)	P1 (mm)	W (mm)	Pin1 Quadrant
MAX213CDBR	SSOP	DB	28	2000	330.0	16.4	8.2	10.5	2.5	12.0	16.0	Q1
MAX213CDWR	SOIC	DW	28	1000	330.0	32.4	11.35	18.67	3.1	16.0	32.0	Q1
MAX213IDBR	SSOP	DB	28	2000	330.0	16.4	8.2	10.5	2.5	12.0	16.0	Q1
MAX213IDWR	SOIC	DW	28	1000	330.0	32.4	11.35	18.67	3.1	16.0	32.0	Q1

TAPE AND REEL BOX DIMENSIONS

*All dimensions are nominal

Device	Package Type	Package Drawing	Pins	SPQ	Length (mm)	Width (mm)	Height (mm)
MAX213CDBR	SSOP	DB	28	2000	367.0	367.0	38.0
MAX213CDWR	SOIC	DW	28	1000	350.0	350.0	66.0
MAX213IDBR	SSOP	DB	28	2000	367.0	367.0	38.0
MAX213IDWR	SOIC	DW	28	1000	350.0	350.0	66.0

DW (R-PDSO-G28)

PLASTIC SMALL OUTLINE

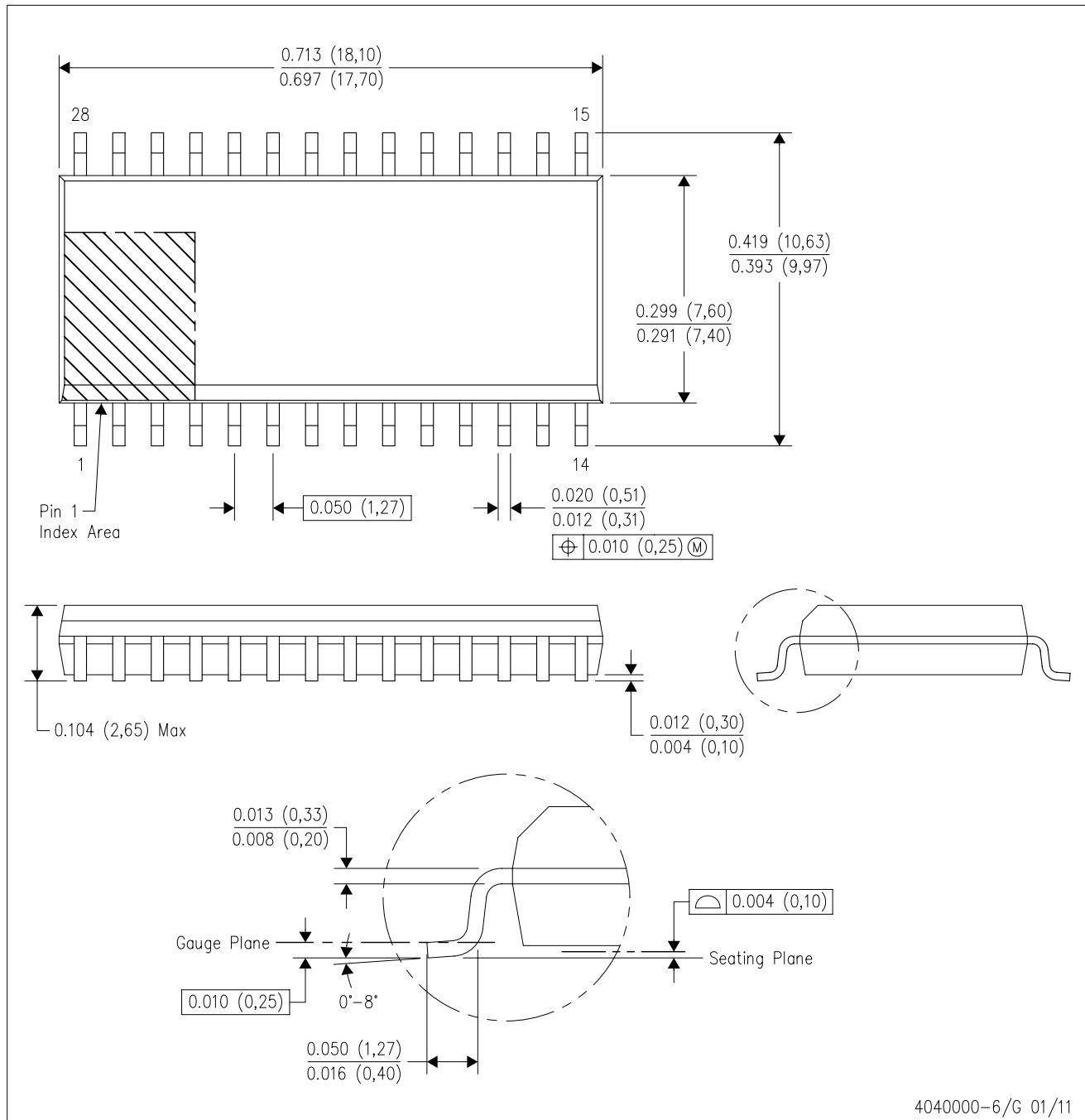

4040000-6/G 01/11

- NOTES:
- All linear dimensions are in inches (millimeters). Dimensioning and tolerancing per ASME Y14.5M-1994.
 - This drawing is subject to change without notice.
 - Body dimensions do not include mold flash or protrusion not to exceed 0.006 (0,15).
 - Falls within JEDEC MS-013 variation AE.

DB0028A

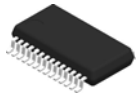

PACKAGE OUTLINE

SSOP - 2 mm max height

SMALL OUTLINE PACKAGE

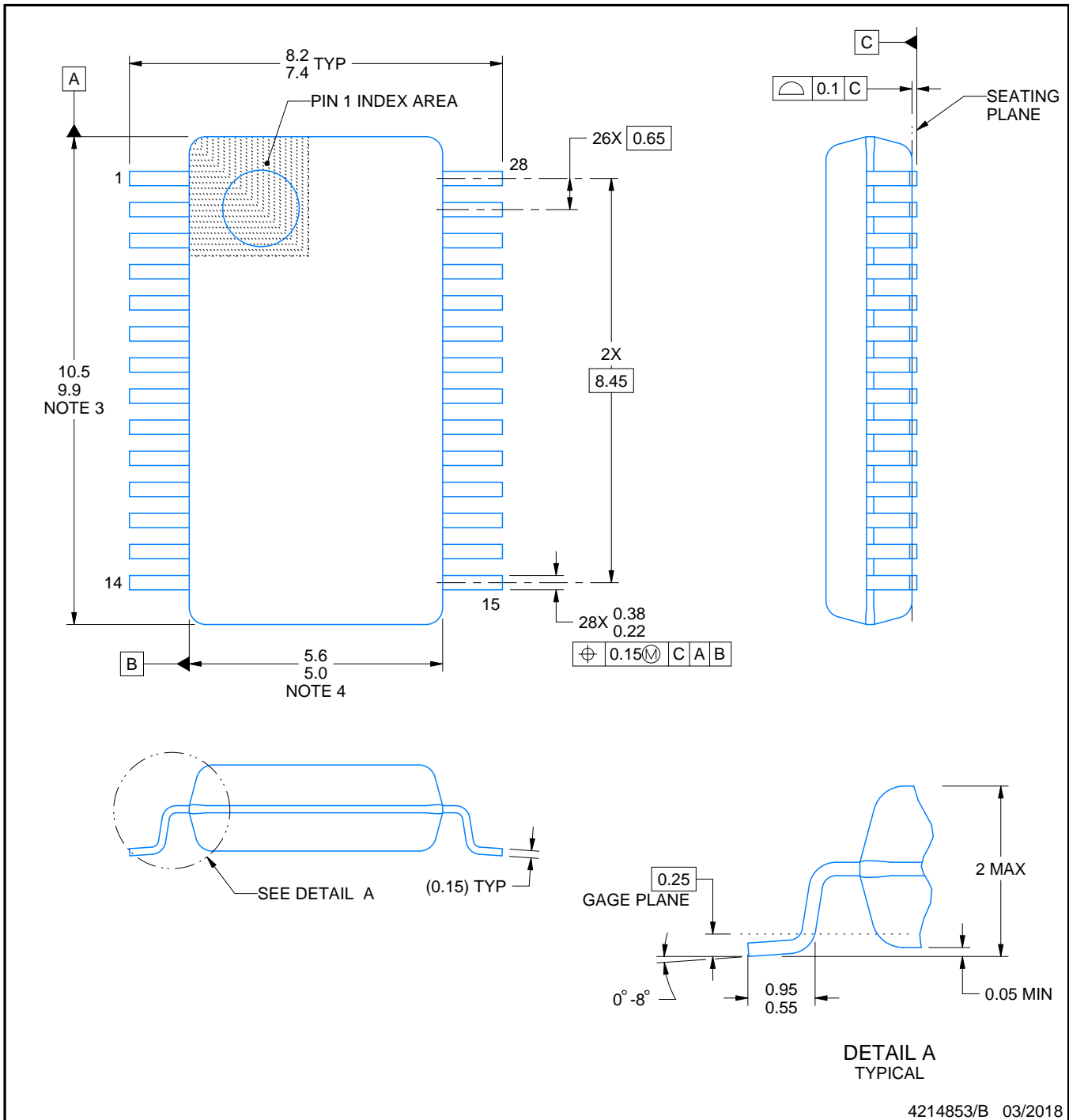

4214853/B 03/2018

NOTES:

1. All linear dimensions are in millimeters. Any dimensions in parenthesis are for reference only. Dimensioning and tolerancing per ASME Y14.5M.
2. This drawing is subject to change without notice.
3. This dimension does not include mold flash, protrusions, or gate burrs. Mold flash, protrusions, or gate burrs shall not exceed 0.15 mm per side.
4. This dimension does not include interlead flash. Interlead flash shall not exceed 0.25 mm per side.
5. Reference JEDEC registration MO-150.

EXAMPLE BOARD LAYOUT

DB0028A

SSOP - 2 mm max height

SMALL OUTLINE PACKAGE

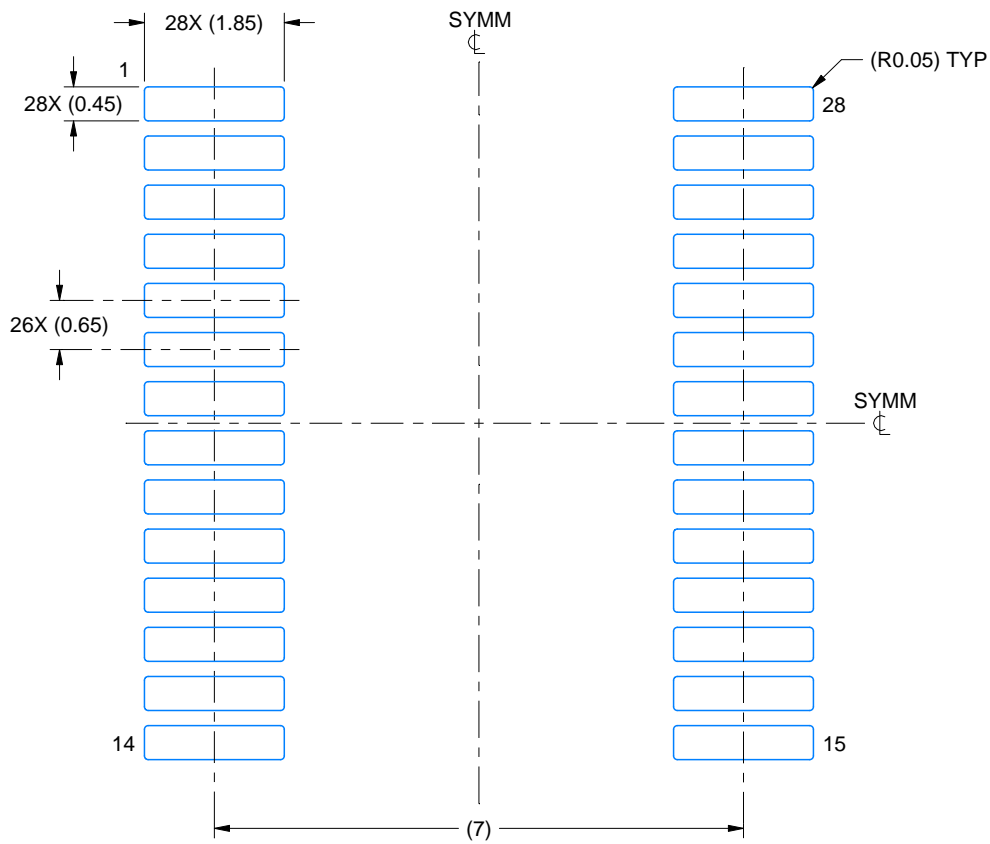

LAND PATTERN EXAMPLE
EXPOSED METAL SHOWN
SCALE: 10X

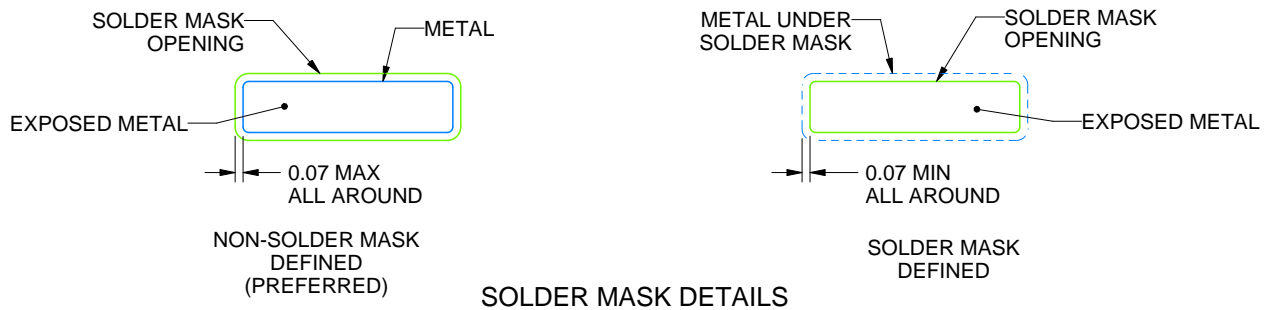

4214853/B 03/2018

NOTES: (continued)

- 6. Publication IPC-7351 may have alternate designs.
- 7. Solder mask tolerances between and around signal pads can vary based on board fabrication site.

EXAMPLE STENCIL DESIGN

DB0028A

SSOP - 2 mm max height

SMALL OUTLINE PACKAGE

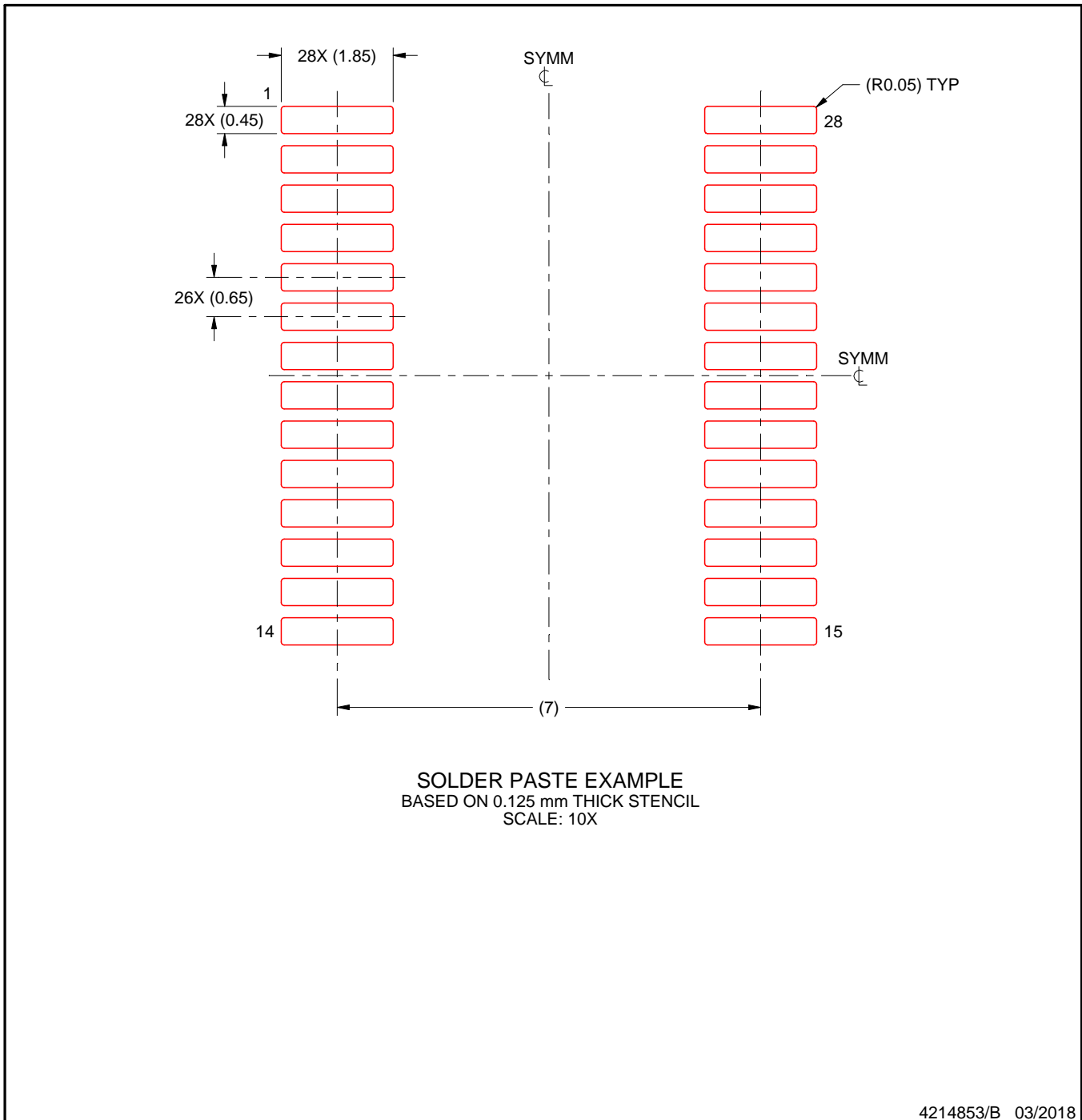

NOTES: (continued)

8. Laser cutting apertures with trapezoidal walls and rounded corners may offer better paste release. IPC-7525 may have alternate design recommendations.
9. Board assembly site may have different recommendations for stencil design.

IMPORTANT NOTICE AND DISCLAIMER

TI PROVIDES TECHNICAL AND RELIABILITY DATA (INCLUDING DATASHEETS), DESIGN RESOURCES (INCLUDING REFERENCE DESIGNS), APPLICATION OR OTHER DESIGN ADVICE, WEB TOOLS, SAFETY INFORMATION, AND OTHER RESOURCES "AS IS" AND WITH ALL FAULTS, AND DISCLAIMS ALL WARRANTIES, EXPRESS AND IMPLIED, INCLUDING WITHOUT LIMITATION ANY IMPLIED WARRANTIES OF MERCHANTABILITY, FITNESS FOR A PARTICULAR PURPOSE OR NON-INFRINGEMENT OF THIRD PARTY INTELLECTUAL PROPERTY RIGHTS.

These resources are intended for skilled developers designing with TI products. You are solely responsible for (1) selecting the appropriate TI products for your application, (2) designing, validating and testing your application, and (3) ensuring your application meets applicable standards, and any other safety, security, or other requirements. These resources are subject to change without notice. TI grants you permission to use these resources only for development of an application that uses the TI products described in the resource. Other reproduction and display of these resources is prohibited. No license is granted to any other TI intellectual property right or to any third party intellectual property right. TI disclaims responsibility for, and you will fully indemnify TI and its representatives against, any claims, damages, costs, losses, and liabilities arising out of your use of these resources.

TI's products are provided subject to TI's Terms of Sale (www.ti.com/legal/termsofsale.html) or other applicable terms available either on ti.com or provided in conjunction with such TI products. TI's provision of these resources does not expand or otherwise alter TI's applicable warranties or warranty disclaimers for TI products.

Mailing Address: Texas Instruments, Post Office Box 655303, Dallas, Texas 75265
Copyright © 2019, Texas Instruments Incorporated

Looking for pricing, stock, or lifecycle information?

Click below to explore more details on WIN SOURCE:

 [View MAX213IDBR](#) on WIN SOURCE

 [Texas Instruments](#) Information

Optimize Your Supply Chain with WIN SOURCE Solutions

-  Global Sourcing Solution
-  Obsolete Management
-  Cost Control Management
-  Shortage Management
-  Alternative Solution
-  Excess Inventory Management