



**THE DATASHEET OF
MAX1916EZT+T**





Low-Dropout, Constant-Current Triple White LED Bias Supply

MAX1916

General Description

The MAX1916 low-dropout bias supply for white LEDs is a high-performance alternative to the simple ballast resistors used in conventional white LED designs. The MAX1916 uses a single resistor to set the bias current for three LEDs, which are matched to 0.3%. The MAX1916 consumes only 40 μ A of supply current when enabled and 0.05 μ A when disabled.

The MAX1916's advantages over ballast resistors include significantly better LED-to-LED bias matching, much lower bias variation with supply voltage variation, significantly lower dropout voltage, and in some applications, significantly improved efficiency. The MAX1916 requires a 200mV dropout at a 9mA load on each output to match the LED brightness.

The MAX1916 is available in a space-saving 6-pin Thin SOT23 package.

Features

- ◆ Low 200mV Dropout at 9mA
- ◆ Up to 60mA/LED Bias Current
- ◆ 0.3% LED Current Matching
- ◆ Simple LED Brightness Control
- ◆ Low 40 μ A Supply Current
- ◆ Low 0.05 μ A Shutdown Current
- ◆ 2.5V to 5.5V Supply Voltage Range
- ◆ Thermal Shutdown Protection
- ◆ Tiny 6-Pin Thin SOT23 Package (1mm High)

Applications

Next-Generation Wireless Handsets
PDAs, Palmtops, and Handy Terminals
Digital Cameras, Camcorders
Battery-Powered Equipment

Ordering Information

PART	TEMP. RANGE	PIN-PACKAGE	TOP MARK
MAX1916EZT	-40°C to +85°C	6 Thin SOT23	AAAG

Typical Operating Circuit

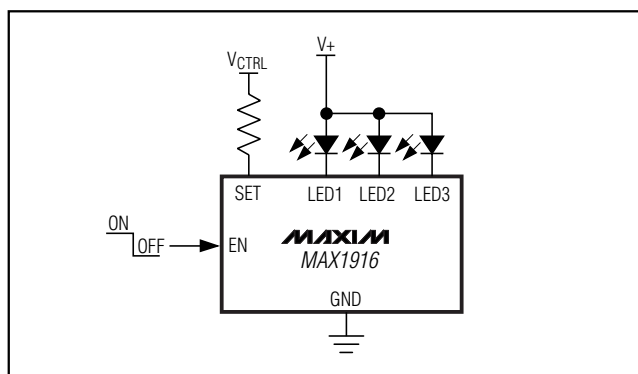

Pin Configuration

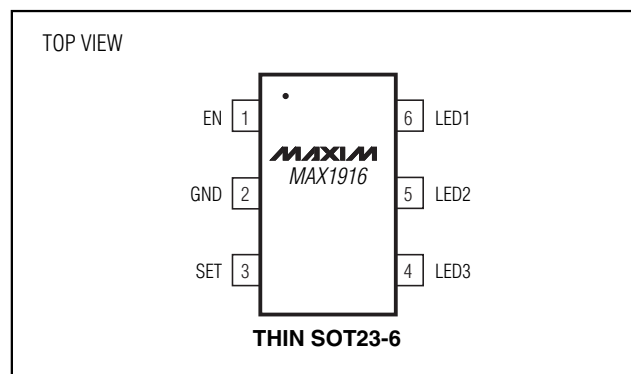

Low-Dropout, Constant-Current Triple White LED Bias Supply

ABSOLUTE MAXIMUM RATINGS

EN, SET, LED1, LED2, LED3 to GND	-0.3V to +6V	Operating Temperature Range	-40°C to +85°C
Continuous Power Dissipation (T _A = +70°C)		Storage Temperature Range	-65°C to +150°C
6-Pin Thin SOT23 (derate 9.1mW/°C above +70°C) ...	727mW	Lead Temperature (soldering, 10s).....	300°C

Stresses beyond those listed under "Absolute Maximum Ratings" may cause permanent damage to the device. These are stress ratings only, and functional operation of the device at these or any other conditions beyond those indicated in the operational sections of the specifications is not implied. Exposure to absolute maximum rating conditions for extended periods may affect device reliability.

ELECTRICAL CHARACTERISTICS

(V_{EN} = 3.3V, V_{LED1} = V_{LED2} = V_{LED3} = 1V, T_A = -40°C to +85°C, unless otherwise noted. Typical values are at T_A = +25°C.) (Note 1)

PARAMETER	SYMBOL	CONDITIONS	MIN	TYP	MAX	UNITS
Operating Voltage Range	V _{EN}	EN is the power-supply input	2.5		5.5	V
Undervoltage Lockout Threshold	V _{UVLO}	V _{EN} rising	2.2		2.47	V
		Hysteresis		85		mV
SET Input Current Range	I _{SET}		5		260	μA
SET to LED_ Current Ratio		I _{LED} /I _{SET} , I _{SET} = 42μA	207	230	253	A/A
SET Bias Voltage	V _{SET}	I _{SET} = 42μA	1.154	1.215	1.276	V
SET Leakage Current in Shutdown		EN = GND, V _{SET} = 3.3V	T _A = -40°C to +25°C	0.01	1	μA
			T _A = -40°C to +85°C		5	
LED_ to-LED_ Current Matching		I _{SET} = 42μA		0.3	5	%
Maximum LED_ Sink Current	I _{LED_}	Each LED_	60			mA
LED_ Dropout Voltage		I _{SET} = 22μA (Note 2)		100	180	mV
		I _{SET} = 42μA (Note 3)		200	360	
		I _{SET} = 84μA (Note 3)		230	410	
LED_ Leakage Current in Shutdown		V _{LED1} = V _{LED2} = V _{LED3} = 5.5V, EN = GND, each LED_	T _A = +25°C	0.01	1	μA
Input High Voltage	V _{IH}	V _{EN} > V _{IH} for enable	2.5			V
Input Low Voltage	V _{IL}	V _{EN} < V _{IL} for disable			2.2	
EN Input Bias Current	I _{EN}	V _{EN} = 2.5V to 5.5V, EN is the power-supply input		40	100	μA
		V _{EN} = 0.4V	T _A = +25°C	0.05	1	
Thermal Shutdown Temperature				170		°C
Thermal Shutdown Hysteresis				10		°C

Note 1: Limits are 100% production tested at T_A = +25°C. Limits over the operating temperature range are guaranteed through correlation using statistical quality control (SQC) methods.

Note 2: Dropout Voltage is defined as the LED_ to GND voltage at which current sink into LED_ drops 20% from the value at V_{LED} = 1V.

Note 3: Dropout Voltage is defined as the LED_ to GND voltage at which current sink into LED_ drops 10% from the value at V_{LED} = 1V.

Low-Dropout, Constant-Current Triple White LED Bias Supply

Typical Operating Characteristics

($V_{EN} = 3.3V$, $V_{CTRL} = 3.3V$, $R_{SET} = 24.9k\Omega$, $V_+ = 5V$, $T_A = +25^\circ C$, unless otherwise noted.) (Circuit of Figure 1)

MAX1916

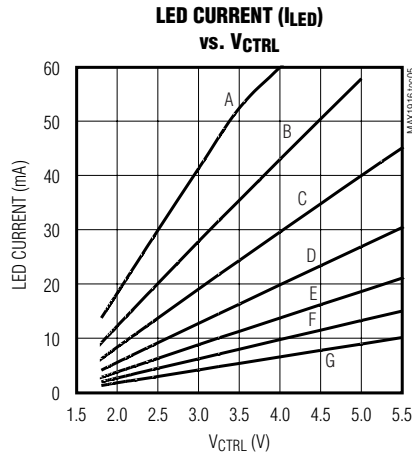
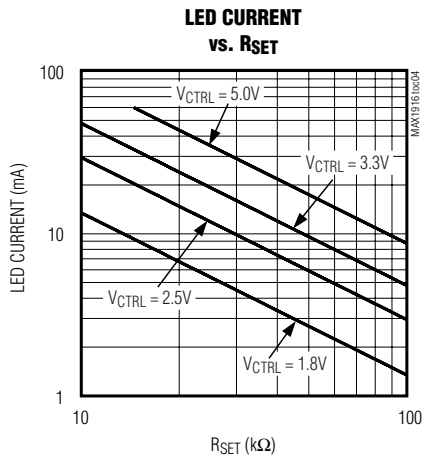
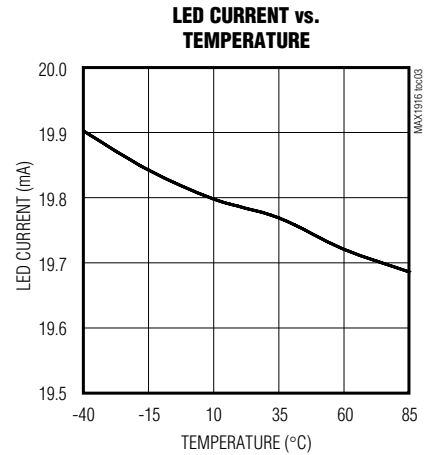
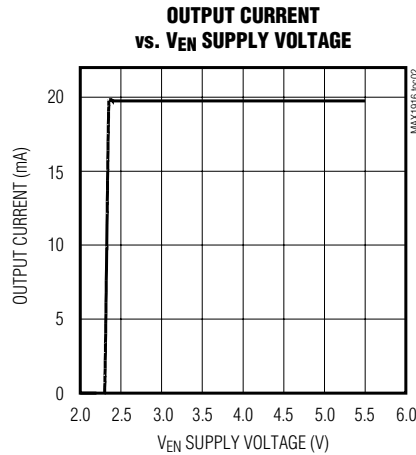
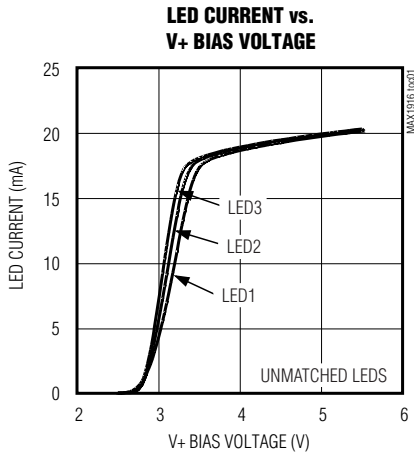

- A: $R_{SET} = 10k\Omega$
- B: $R_{SET} = 15k\Omega$
- C: $R_{SET} = 22k\Omega$
- D: $R_{SET} = 33k\Omega$
- E: $R_{SET} = 47k\Omega$
- F: $R_{SET} = 68k\Omega$
- G: $R_{SET} = 100k\Omega$

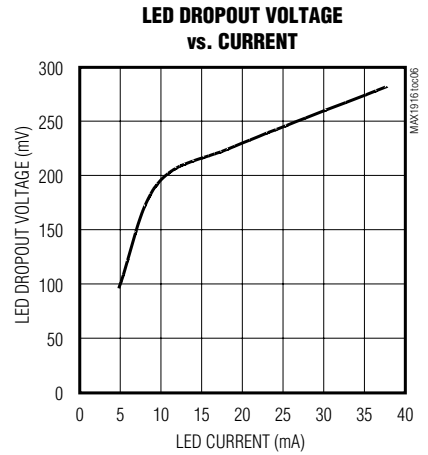

Low-Dropout, Constant-Current Triple White LED Bias Supply

Typical Operating Characteristics (continued)

($V_{EN} = 3.3V$, $V_{CTRL} = 3.3V$, $R_{SET} = 24.9k\Omega$, $V_+ = 5V$, $T_A = +25^\circ C$, unless otherwise noted.) (Circuit of Figure 1)

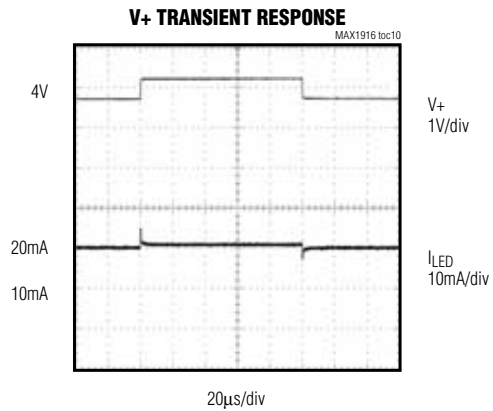
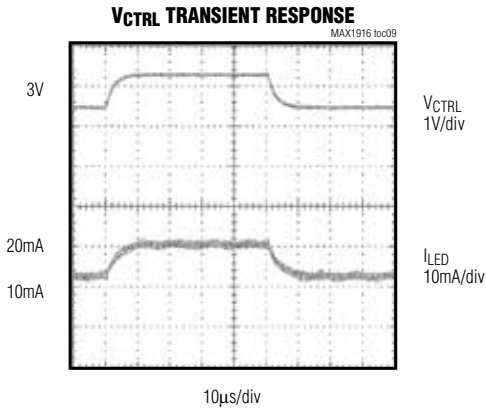
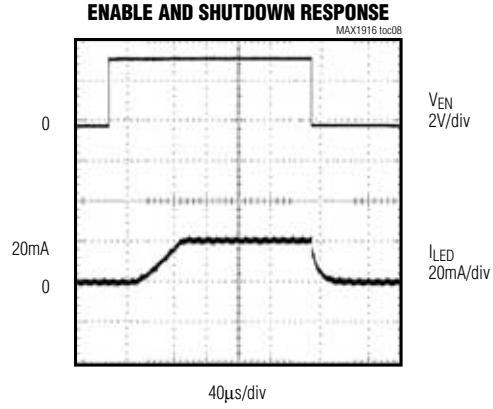
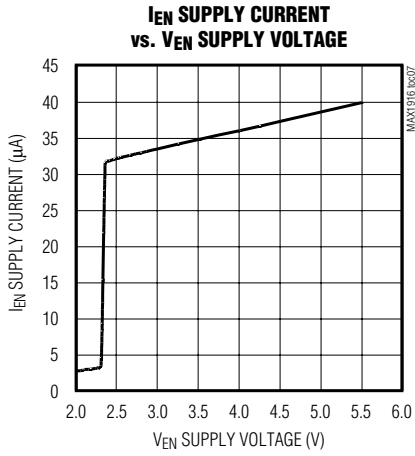

Low-Dropout, Constant-Current Triple White LED Bias Supply

MAX1916

Pin Description

PIN	NAME	FUNCTION
1	EN	Enable Input/Power Input. Drive high (> 2.5V) to enable; drive low (< 2.2V) to disable. When disabled, SET, LED1, LED2, and LED3 are high impedance. When enabled, EN is the power input for the MAX1916.
2	GND	Ground
3	SET	Bias Current Set Input. The current flowing into SET sets the bias current into each LED by $I_{LED_} = 230 \times I_{SET}$. V_{SET} is internally biased to 1.215V. SET is high impedance when EN is low.
4	LED3	LED 3 Cathode Connection. Current flowing into LED3 is 230 times the current flowing into SET. LED3 is high impedance when EN is low.
5	LED2	LED 2 Cathode Connection. Current flowing into LED2 is 230 times the current flowing into SET. LED2 is high impedance when EN is low.
6	LED1	LED 1 Cathode Connection. Current flowing into LED1 is 230 times the current flowing into SET. LED1 is high impedance when EN is low.

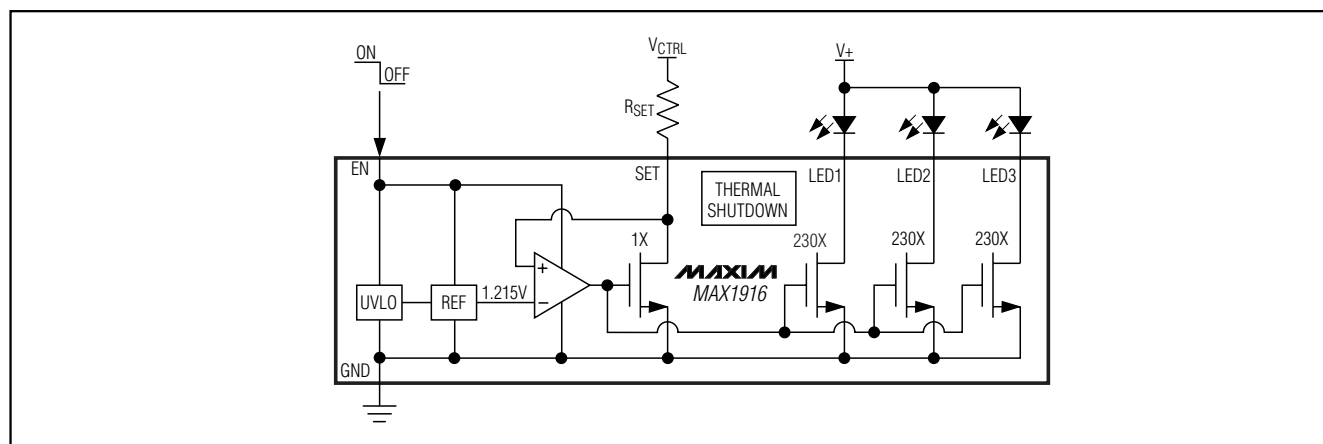

Figure 1. MAX1916 Simplified Functional Diagram

Detailed Description

The MAX1916 provides constant-current bias supply for white LED designs. The MAX1916 uses a single resistor to set the bias current for up to three LEDs. LED bias currents are matched to 0.3% by the MAX1916's unique current-matching architecture (Figure 1). Supply current (I_{EN}) is a low 40 μ A in normal operation and 0.05 μ A when disabled.

The MAX1916 offers several advantages over using ballast resistors, such as improved LED-to-LED brightness matching, lower bias variation with supply voltage changes, significantly lower dropout voltage, and in some applications, significantly improved efficiency.

The MAX1916 achieves a 200mV dropout with a 9mA load on each output.

For circuits requiring only one or two LEDs, leave unused LED outputs unconnected.

Enable Input

EN powers the input of the MAX1916. Drive EN high (> 2.5V) to enable the device; drive EN low (< 2.2V) to disable the device. When driven high, EN draws 40 μ A to power the IC. Driving EN low forces LED1, LED2, LED3, and SET into a high-impedance state.

Low-Dropout, Constant-Current Triple White LED Bias Supply

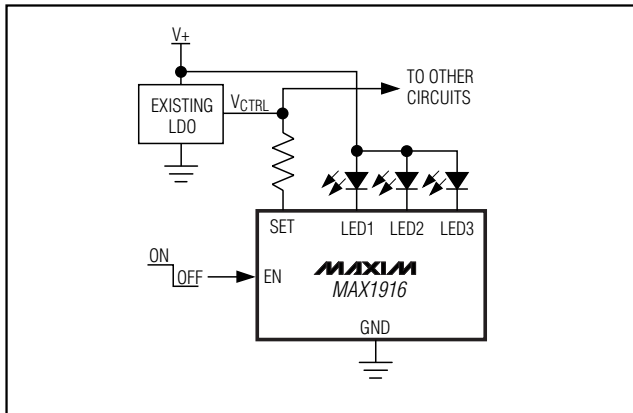

Figure 2. Very Low-Cost, High-Efficiency Solution

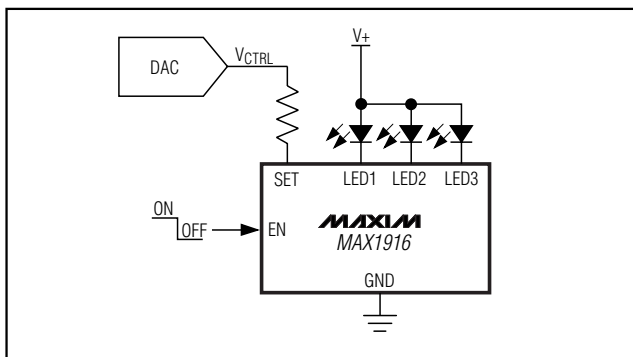

Figure 3. Brightness Adjust Using DAC

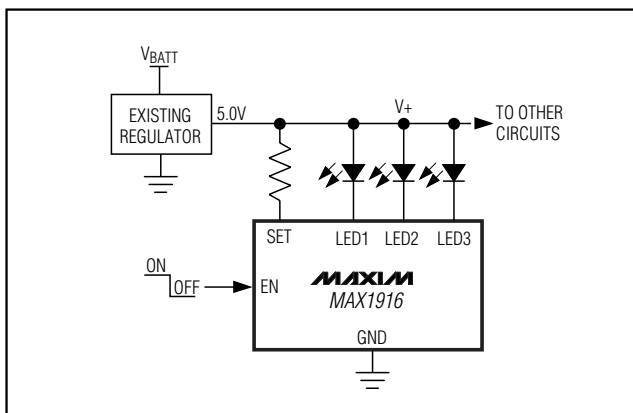

Figure 4. Existing 5V Supply Circuit

Setting the Output Current

SET controls the LED bias current. Current flowing into LED1, LED2, and LED3 is 230 times greater than the current flowing into SET. Set the output current as follows:

$$I_{LED_} = 230 \frac{(V_{CTRL} - V_{SET})}{R_{SET}}$$

where $V_{SET} = 1.215V$, V_{CTRL} is an external voltage between 1.8V and 5.5V, and R_{SET} is the resistor connected between V_{CTRL} and SET (Figure 1).

Applications Information

- 1) Very Low-Cost, High-Efficiency Solution (Figure 2). A battery (single Li+ or three NiMH cells) powers the LEDs directly. This is the least expensive and most efficient architecture. Due to the high forward voltage of white LEDs (3.3V), the LED brightness may dim slightly at the end of battery life. The MAX1916's current-regulating architecture and low dropout greatly minimize this effect compared to using simple ballast resistors. The enable function of the MAX1916 turns on and off the LEDs. An existing low-dropout regulator is used as V_{CTRL} .
- 2) Brightness Adjustment Using a DAC (Figure 3). A DAC is used as V_{CTRL} such that the LED brightness may be dynamically adjusted to eliminate factory calibration. A battery (single Li+ or three NiMH cells) or a regulated power source drives the LEDs.
- 3) Existing 5V Supply (Figure 4). Use an existing system regulator, such as the MAX684, to provide the required LED voltage and provide power to other circuits. Due to the high forward voltage of white LEDs (3.3V), use a 3.6V to 5.5V regulated supply to provide enough voltage headroom such that the LEDs will maintain constant brightness for any battery voltage. Use the existing regulated supply as V_{CTRL} .

Chip Information

TRANSISTOR COUNT: 220

PROCESS: BiCMOS

Low-Dropout, Constant-Current Triple White LED Bias Supply

Package Information

MAX1916

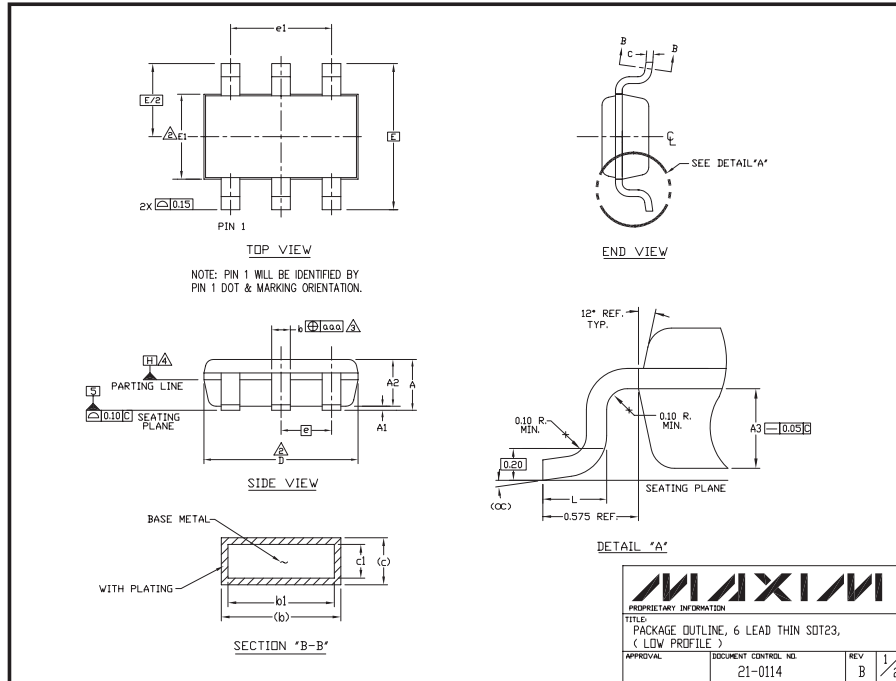

NOTES:

- ALL DIMENSIONS ARE IN MILLIMETERS.
- "D" AND "E1" ARE REFERENCE DATUM AND DO NOT INCLUDE MOLD FLASH OR PROTRUSIONS, AND ARE MEASURED AT THE BOTTOM PARTING LINE. MOLD FLASH OR PROTRUSION SHALL NOT EXCEED 0.15mm ON "D" AND 0.25mm ON "E" PER SIDE.
- THE LEAD WIDTH DIMENSION DOES NOT INCLUDE DAMBAR PROTRUSION. ALLOWABLE DAMBAR PROTRUSION SHALL BE 0.07mm TOTAL IN EXCESS OF THE LEAD WIDTH DIMENSION AT MAXIMUM MATERIAL CONDITION.
- DATUM PLANE "H" LOCATED AT MOLD PARTING LINE AND COINCIDENT WITH LEAD, WHERE LEAD EXITS PLASTIC BODY AT THE BOTTOM OF PARTING LINE.
- THE LEAD TIPS MUST LIE WITHIN A SPECIFIED TOLERANCE ZONE. THIS TOLERANCE ZONE IS DEFINED BY TWO PARALLEL LINES. ONE PLANE IS THE SEATING PLANE, DATUM [-C-]; AND THE OTHER PLANE IS AT THE SPECIFIED DISTANCE FROM [-C-] IN THE DIRECTION INDICATED. FORMED LEADS SHALL BE PLANAR WITH RESPECT TO ONE ANOTHER WITH 0.10mm AT SEATING PLANE.
- THIS PART IS COMPLIANT WITH JEDEC SPECIFICATION MO-193 EXCEPT FOR THE "e" DIMENSION WHICH IS 0.95mm INSTEAD OF 1.00mm. THIS PART IS IN FULL COMPLIANCE TO EIAJ SPECIFICATION SC-74.

SYMBOLS			
	MIN	NDM	MAX
A	-	-	1.10
A1	0.05	0.075	0.10
A2	0.85	0.88	0.90
A3	0.50 BSC		
b	0.30	-	0.45
b1	0.25	0.35	0.40
c	0.15	-	0.20
c1	0.12	0.127	0.15
D	2.80	2.90	3.00
E	2.75 BSC		
E1	1.55	1.60	1.65
L	0.30	0.40	0.50
e1	1.90 BSC		
e	0.95 BSC		
OC	0°	4°	8°
o.o.g.	0.20		

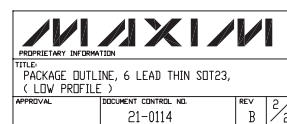

Maxim cannot assume responsibility for use of any circuitry other than circuitry entirely embodied in a Maxim product. No circuit patent licenses are implied. Maxim reserves the right to change the circuitry and specifications without notice at any time.

Maxim Integrated Products, 120 San Gabriel Drive, Sunnyvale, CA 94086 408-737-7600

Looking for pricing, stock, or lifecycle information?

Click below to explore more details on WIN SOURCE:

 [View MAX1916EZT+T on WIN SOURCE](#)

 [Maxim Integrated](#) Information

Optimize Your Supply Chain with WIN SOURCE Solutions

-  Global Sourcing Solution
-  Obsolete Management
-  Cost Control Management
-  Shortage Management
-  Alternative Solution
-  Excess Inventory Management