



Linear Charger for Single-Cell Li+ Battery

MAX1898

General Description

The MAX1898, with an external PNP or PMOS transistor, forms a complete charger for 1-cell lithium-ion (Li+) batteries. The MAX1898 provides accurate constant-current/constant-voltage charging. Battery regulation voltage accuracy is $\pm 0.75\%$ for optimum battery performance and cycle life. Charging current is user set, but is sensed internally so no external current-sense resistor is needed. The MAX1898 also provides outputs to monitor charge status, presence-of-input power source, and charge current. Additional features include shutdown, optional charge-cycle restart without input-power cycling, selectable charge termination safety timer, and low-current preconditioning for deeply discharged cells.

The MAX1898 offers the maximum integration and functionality in the smallest, most basic application circuit possible. Very few external components are required.

The MAX1898 offers two versions to safely charge all Li+ battery chemistries. The battery regulation voltage is 4.2V for the MAX1898EUB42 and 4.1V for the MAX1898EUB41. Both are available in a 10-pin ultra-thin μ MAX package.

Applications

- Single-Cell Li+ Powered Portables
- Self-Charging Battery Packs
- PDA's
- Cell Phones
- Cradle Chargers

Pin Configuration

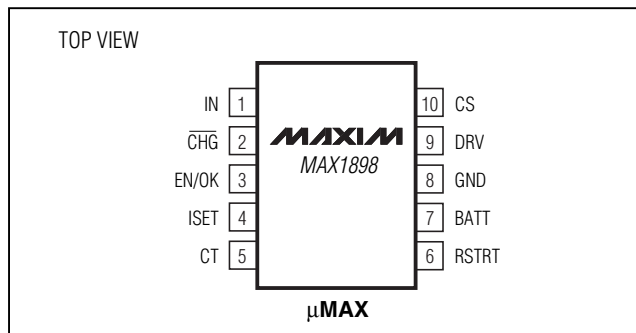

Features

- ◆ Simple, Safe Linear Charger
- ◆ Uses Low-Cost PNP or PMOS Pass Element
- ◆ 4.5V to 12V Input Range
- ◆ Internal Current-Sense Resistor
- ◆ $\pm 0.75\%$ Voltage Accuracy
- ◆ Programmable Charging Current
- ◆ Automatic Input Power-Source Detection
- ◆ LED Charge Status Indicator
- ◆ Programmable Safety Timer
- ◆ Current-Sense Monitor Output
- ◆ Optional/Adjustable Auto-Restart
- ◆ Small μ MAX Package

Ordering Information

PART	TEMP RANGE	PIN-PACKAGE
MAX1898EUB42	-40°C to +85°C	10 μ MAX
MAX1898EUB41	-40°C to +85°C	10 μ MAX

Typical Operating Circuit

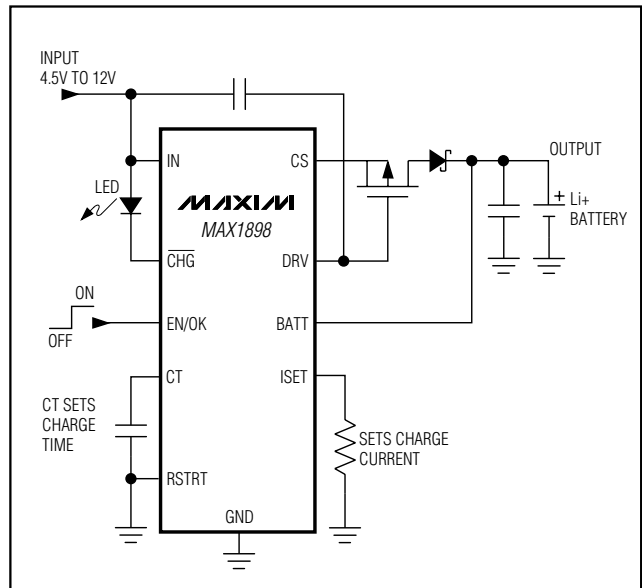

Linear Charger for Single-Cell Li+ Battery

ABSOLUTE MAXIMUM RATINGS

IN, DRV, CS, $\overline{\text{CHG}}$ to GND-0.3V to +14V
 BATT, EN, ISET, RSTRT, CT to GND-0.3V to +6V
 DRV to IN.....-14V to +0.3V
 IN to CS Current±2A
 DRV Continuous Current±10mA

Continuous Power Dissipation ($T_A = +70^\circ\text{C}$)
 10-Pin μMAX (derate 5.6mW/ $^\circ\text{C}$ above $+70^\circ\text{C}$)444mW
 Operating Temperature Range-40 $^\circ\text{C}$ to +85 $^\circ\text{C}$
 Junction Temperature+150 $^\circ\text{C}$
 Storage Temperature Range-65 $^\circ\text{C}$ to +150 $^\circ\text{C}$
 Lead Temperature (soldering, 10s)+300 $^\circ\text{C}$

Stresses beyond those listed under "Absolute Maximum Ratings" may cause permanent damage to the device. These are stress ratings only, and functional operation of the device at these or any other conditions beyond those indicated in the operational sections of the specifications is not implied. Exposure to absolute maximum rating conditions for extended periods may affect device reliability.

ELECTRICAL CHARACTERISTICS

($V_{\text{IN}} = 8\text{V}$, $V_{\text{BATT}} = 4\text{V}$, EN/OK = open, RSET = 2.8k Ω , RSTRT = GND, $T_A = 0^\circ\text{C}$ to +85 $^\circ\text{C}$, unless otherwise noted. Typical values are at $T_A = +25^\circ\text{C}$.)

PARAMETER	CONDITIONS	MIN	TYP	MAX	UNITS	
Supply Voltage Range		4.5		12	V	
Input OK Trip Point, IN Rising ($V_{\text{IN}} - V_{\text{BATT}}$)		45	70	100	mV	
Input OK Trip Point, IN Falling ($V_{\text{IN}} - V_{\text{BATT}}$)		30	55	85	mV	
V_{IN} Input OK Trip Point, IN Rising		4.0	4.25	4.5	V	
V_{IN} Input OK Trip Point, IN Falling		3.9	4.15	4.4	V	
EN/OK Sink Current (When Input Power Not OK)	$V_{\text{IN}} = 3.9\text{V}$, $V_{\text{BATT}} = 4\text{V}$, $V_{\text{EN/OK}} = 0.8\text{V}$	100			μA	
EN/OK Source Current (When Input Power OK)	$V_{\text{EN/OK}} = 2\text{V}$	5	10	20	μA	
EN/OK Logic Input High	$4.5\text{V} \leq V_{\text{IN}} \leq 12\text{V}$	2			V	
EN/OK Logic Input Low	$4.5\text{V} \leq V_{\text{IN}} \leq 12\text{V}$			0.6	V	
BATT Input Current	Done, RSTRT = GND, $V_{\text{BATT}} = 4.1\text{V}$ for MAX1898EUB42 and 4.0V for MAX1898EUB41		40	100	μA	
	Done, RSTRT = open, $V_{\text{BATT}} = 4.1\text{V}$ for MAX1898EUB42 and 4.0V for MAX1898EUB41		4	10		
	EN/OK = GND		4	10		
	$V_{\text{IN}} = 4\text{V}$		3	10		
IN, CS Input Current	$V_{\text{IN}} = V_{\text{BATT}} = 4\text{V}$ ($I_{\text{IN}} + I_{\text{CS}}$)		2	10	μA	
	$V_{\text{IN}} = 12\text{V}$, ($I_{\text{IN}} + I_{\text{CS}}$), done, RSTRT = open		2	5	mA	
VOLTAGE LOOP						
Voltage-Loop Set Point	MAX1898EUB42	4.168	4.2	4.232	V	
	MAX1898EUB41	4.069	4.1	4.131		
Voltage-Loop Gain	$\Delta V_{\text{DRV}}/\Delta V_{\text{BATT}}$		51		dB	
V_{BATT} Prequal Voltage Threshold	Timers running	MAX1898EUB42	2.394	2.520	2.646	V
		MAX1898EUB41	2.337	2.460	2.583	
DRV Sink Current	$V_{\text{DRV}} = V_{\text{IN}} - 1\text{V}$, $V_{\text{BATT}} = 3.5\text{V}$	4			mA	
DRV Output Resistance			470		Ω	

Linear Charger for Single-Cell Li+ Battery

MAX1898

ELECTRICAL CHARACTERISTICS (continued)

($V_{IN} = 8V$, $V_{BATT} = 4V$, EN/OK = open, RSET = 2.8k Ω , RSTRT = GND, $T_A = 0^{\circ}C$ to $+85^{\circ}C$, unless otherwise noted. Typical values are at $T_A = +25^{\circ}C$.)

PARAMETER	CONDITIONS	MIN	TYP	MAX	UNITS
Maximum Voltage ($V_{IN} - V_{DRV}$)	$V_{BATT} = 3.5V$	3.5		7	V
V_{BATT} Restart Threshold (As a Percentage of Voltage-Loop Set Point)	RSTRT = GND	92	95.25	98	%
RSTRT Internal Resistance			100		k Ω
CURRENT LOOP					
Internal Current-Sense Resistance	IN to CS pin-to-pin resistance	50	105	200	m Ω
RMS Charge Current				1.4	A
Current-Sense Amplifier Gain, I _{SET} to I _{IN} Fast Charge	I _{CS} = 500mA, V _{SET} = 1.4V	0.95	1	1.05	mA/A
Current-Sense Amplifier Gain, I _{SET} to I _{IN} Prequal	I _{CS} = 50mA, V _{SET} = 0.14V, $V_{BATT} = 2V$	0.73	1	1.30	mA/A
Current-Loop Regulation Set Point	RSET = 2.8k Ω , $V_{BATT} = 3.5V$, closed-loop performance	450	500	550	mA
Current-Loop Gain	$\Delta V_{DRV}/\Delta V_{ISET}$		26		dB
\overline{CHG} Trip Threshold (As a Percentage of Full Load Current)	I _{LOAD} falling, RSET = 2.8k Ω	15	20	25	%
	I _{LOAD} rising, RSET = 2.8k Ω	17	22	27	
TIMER FUNCTION					
Timer Source/Sink Current	V _{CT} = 0.9V		5		μA
Timer Accuracy	C _{CT} = 100nF for 2 hours, 54 minutes nominal	-10		+10	%
\overline{CHG} Output Low Current	V _{\overline{CHG}} = 1V	4	5	6	mA
\overline{CHG} Output High Leakage	V _{\overline{CHG}} = 12V			1	μA
\overline{CHG} Blink Rate	Fault state (50% duty cycle), CT = 100nF	1	1.5	2	Hz

ELECTRICAL CHARACTERISTICS

($V_{IN} = 8V$, $V_{BATT} = 4V$, EN/OK = open, RSET = 2.8k Ω , RSTRT = GND, $T_A = -40^{\circ}C$ to $+85^{\circ}C$, unless otherwise noted.)

PARAMETER	CONDITIONS	MIN	MAX	UNITS
Supply Voltage Range		4.5	12	V
Input OK Trip Point, IN Rising ($V_{IN} - V_{BATT}$)		45	100	mV
Input OK Trip Point, IN Falling ($V_{IN} - V_{BATT}$)		30	85	mV
V_{IN} Input OK Trip Point, IN Rising		4.0	4.5	V
V_{IN} Input OK Trip Point, IN Falling		3.9	4.4	V
EN/OK Sink Current (When Input Power Not OK)	$V_{IN} = 3.9V$, $V_{BATT} = 4V$, $V_{EN/OK} = 0.8V$	100		μA
EN/OK Source Current (When Input Power OK)	$V_{EN/OK} = 2V$	5	20	μA
EN/OK Logic Input High	$4.5V \leq V_{IN} \leq 12V$	2		V
EN/OK Logic Input Low	$4.5V \leq V_{IN} \leq 12V$		0.6	V

Linear Charger for Single-Cell Li+ Battery

ELECTRICAL CHARACTERISTICS (continued)

($V_{IN} = 8V$, $V_{BATT} = 4V$, EN/OK = open, RSET = 2.8k Ω , RSTRT = GND, $T_A = -40^{\circ}C$ to $+85^{\circ}C$, unless otherwise noted.)

PARAMETER	CONDITIONS	MIN	MAX	UNITS	
BATT Input Current	Done, RSTRT = GND, $V_{BATT} = 4.1V$ for MAX1898EUB42 and 4.0V for MAX1898EUB41		100	μA	
	Done, RSTRT = open, $V_{BATT} = 4.1V$ for MAX1898EUB42 and 4.0V for MAX1898EUB41		10		
	EN/OK = GND		10		
	$V_{IN} = 4V$		10		
IN, CS Input Current	$V_{IN} = V_{BATT} = 4V$ ($I_{IN} + I_{CS}$)		10	μA	
	$V_{IN} = 12V$, ($I_{IN} + I_{CS}$), done, RSTRT = open		5	mA	
VOLTAGE LOOP					
Voltage-Loop Set Point	MAX1898EUB42	4.137	4.263	V	
	MAX1898EUB41	4.038	4.162		
V_{BATT} Prequal Voltage Threshold	Timers running	MAX1898EUB42	2.394	2.646	V
		MAX1898EUB41	2.337	2.583	
DRV Sink Current	$V_{DRV} = V_{IN} - 1V$, $V_{BATT} = 3.5V$	3.5		mA	
Maximum Voltage ($V_{IN} - V_{DRV}$)	$V_{BATT} = 3.5V$	3	7	V	
V_{BATT} Restart Threshold (As a Percentage of Voltage-Loop Set Point)	RSTRT = GND	92	98	%	
CURRENT LOOP					
Internal Current-Sense Resistance	IN to CS pin-to-pin resistance	50	200	m Ω	
RMS Charge Current			1.4	A	
Current-Sense Amplifier Gain, I_{SET} to I_{IN} Fast Charge	$I_{CS} = 500mA$, $V_{SET} = 1.4V$	0.93	1.07	mA/A	
Current-Sense Amplifier Gain, I_{SET} to I_{IN} Prequal	$I_{CS} = 50mA$, $V_{SET} = 0.14V$, $V_{BATT} = 2V$	0.6	1.50	mA/A	
Current-Loop Regulation Set Point	RSET = 2.8k Ω , $V_{BATT} = 3.5V$, closed-loop performance	440	560	mA	
\overline{CHG} Trip Threshold (As a Percentage of Full Load Current)	I_{LOAD} falling, RSET = 2.8k Ω	15	25	%	
	I_{LOAD} rising, RSET = 2.8k Ω	17	27		
Timer Accuracy	$C_{CT} = 100nF$ for 2 hours, 54 minutes nominal	-13	+13	%	
\overline{CHG} Output Low Current	$V_{\overline{CHG}} = 1V$	3.5	7	mA	
\overline{CHG} Output High Leakage	$V_{\overline{CHG}} = 12V$		1	μA	
\overline{CHG} Blink Rate	Fault state (50% duty cycle), $C_T = 100nF$	1	2	Hz	

Note 1: Specifications to $-40^{\circ}C$ are guaranteed by design and not production tested.

Linear Charger for Single-Cell Li+ Battery

Typical Operating Characteristics

($V_{IN} = 5V$, $V_{BATT} = 4V$, EN/OK = open, RSET = 2.8k Ω , RSTRT = GND, $T_A = +25^\circ C$, unless otherwise noted.)

MAX1898

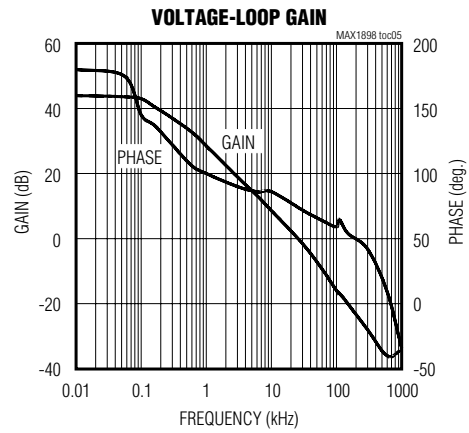
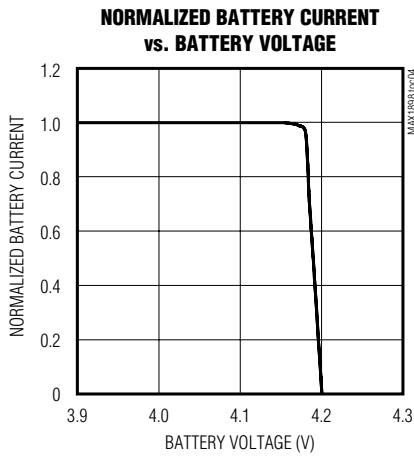
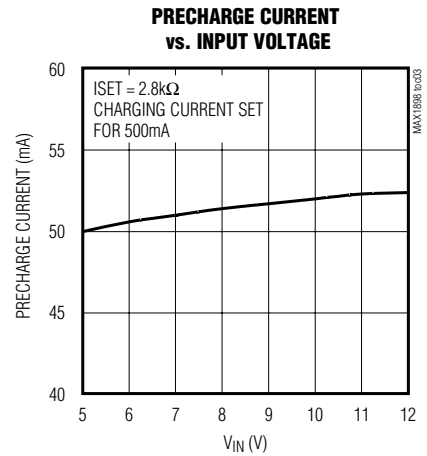
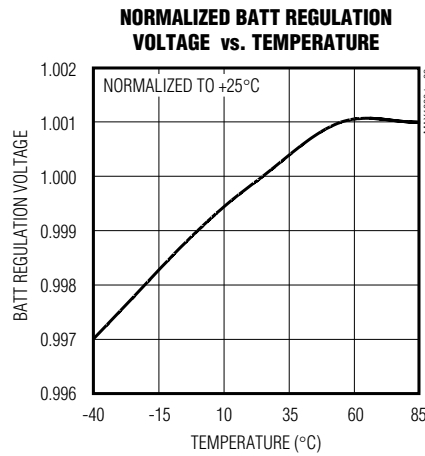
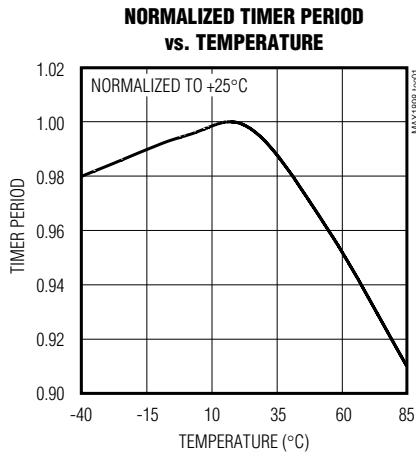

Linear Charger for Single-Cell Li+ Battery

Pin Description

PIN	NAME	FUNCTION
1	IN	Sense Input. Detects power source; positive side of internal current-sense resistor.
2	$\overline{\text{CHG}}$	Open-Drain LED Driver. See Table 1 for $\overline{\text{CHG}}$ output states.
3	EN/OK	Logic-Level Enable Input and Input Power OK Output. Hold low to disable charger. Float for normal operation, drive with an open-drain device to utilize both pin functions, or connect through 10k Ω for logic-controlled ON/OFF. See the <i>EN/OK (EN Input, OK Output)</i> section for details.
4	ISET	ISET serves two functions. It provides an analog output proportional to the actual charge current. Output current from ISET is 1mA per amp of battery charging current. The charging current is set by connecting a resistor from ISET to ground. See the <i>Current-Limit Mode</i> section.
5	CT	Safety Charge Timer Control. Connect timer capacitor to program safety time-out interval; 100nF for approximately three hours. Connect to GND to disable the timer function.
6	RSTRT	Automatic-Restart Control Pin. When tied to GND, a new charging cycle starts if the cell drops 200mV below the battery regulation threshold. The restart threshold may be lowered by connecting a resistor from RSTRT to ground. See the <i>Reinitiating a Charging Cycle</i> section. Automatic restart is disabled when RSTRT is unconnected or when CT is grounded (timer disabled).
7	BATT	Battery Sense Input. Positive terminal of single Li+ cell.
8	GND	Ground
9	DRV	External Transistor Driver. This pin drives the gate/base of an external PMOS/PNP pass transistor.
10	CS	Current-Sense Input. Negative side of internal current-sense resistor. Connect to source/emitter of PMOS/PNP pass transistor.

Detailed Description

The MAX1898 forms a complete charger for 1-cell Li+ batteries. It includes precision voltage control ($\pm 0.75\%$) to optimize both cell performance and cycle life. Factory-set 4.2V (MAX1898EUB42) and 4.1V (MAX1898EUB41) versions charge all common Li+ chemistries. Externally selectable charge current is sensed internally, eliminating the need for a current-sense resistor. The charger also supplies outputs that indicate charge status (CHG), the presence of input power (EN/OK), and charge-current magnitude (ISET). Other features include a shutdown control input (EN/OK), selectable threshold for charge-cycle restart without cycling input power (RSTRT), and a selectable charge termination safety timer. See Figure 1.

The MAX1898 initiates fast charge when any of these conditions are met (see Figure 6):

- An external power source is connected AND the cell voltage is above 2.5V.
- The cell voltage falls to the restart threshold, 4.0V in the MAX1898EUB42, or 3.9V for the MAX1898EUB41.
- The IC is reset by driving the EN/OK pin low and then high again.

- The prequalification cycle ends with the cell reaching 2.5V.

Li+ cells can be damaged when fast-charged from a completely dead state. A fully discharged cell may indicate an abnormal cell condition. As a built-in safety feature, the MAX1898 prequalifies the cell with 10 percent of the user-programmed fast-charge current at the start of a charge cycle. When the cell voltage rises to 2.5V, the MAX1898 begins fast-charging.

Current-Limit Mode

The MAX1898 regulates charging current by linearly controlling an external PMOS or PNP transistor. The maximum charging current is programmed by an external RSET resistor connected from ISET to GND. Select the RSET value based on the following formula:

$$I_{\text{FASTCHG}} = \frac{1400\text{V}}{R_{\text{SET}}}$$

where:

I_{FASTCHG} is in amps and R_{SET} is in ohms.

The ISET pin may also be used to monitor the actual charging current at any time. The output current from

Linear Charger for Single-Cell Li+ Battery

MAX1898

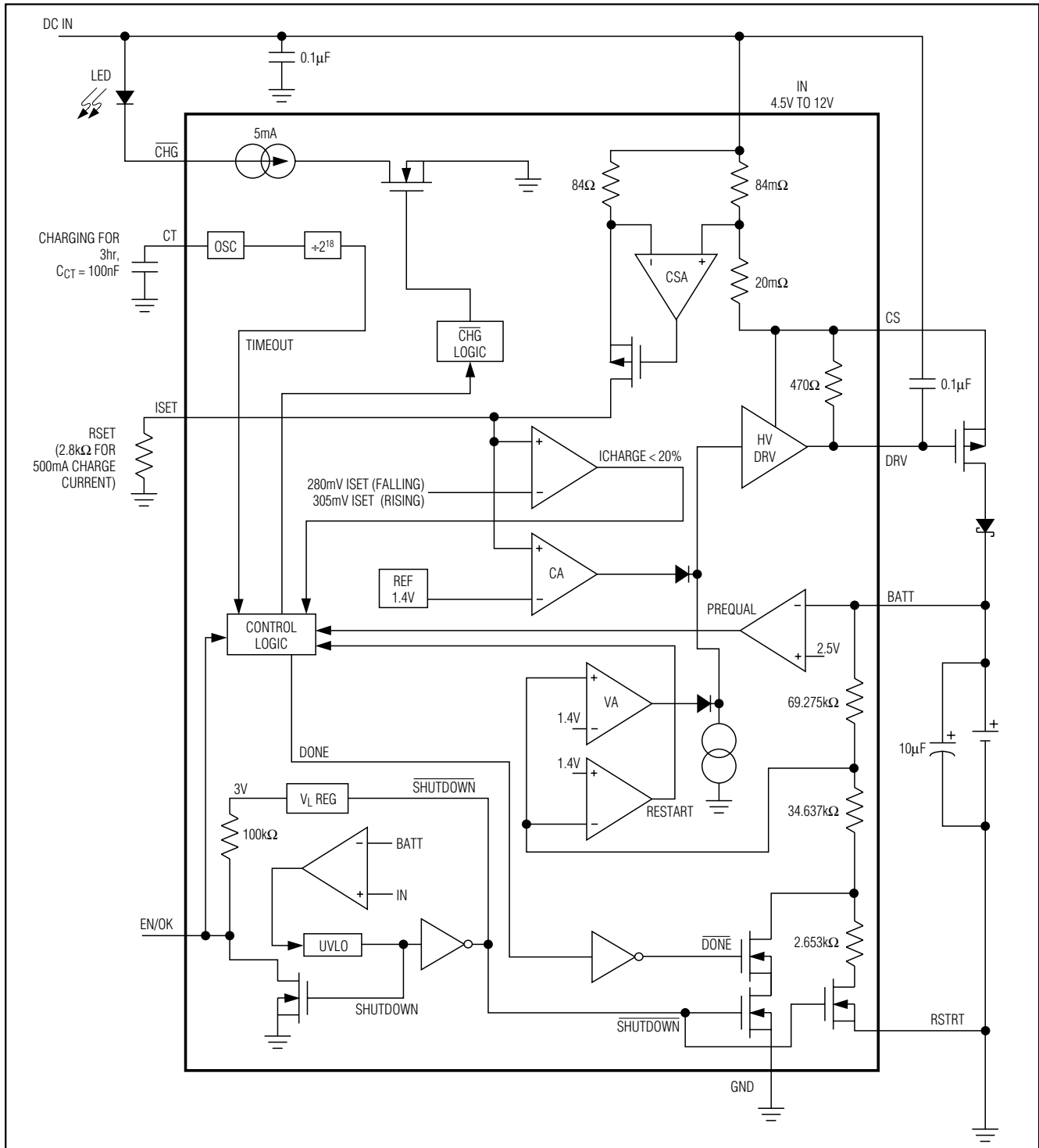

Figure 1. Functional Diagram

Linear Charger for Single-Cell Li+ Battery

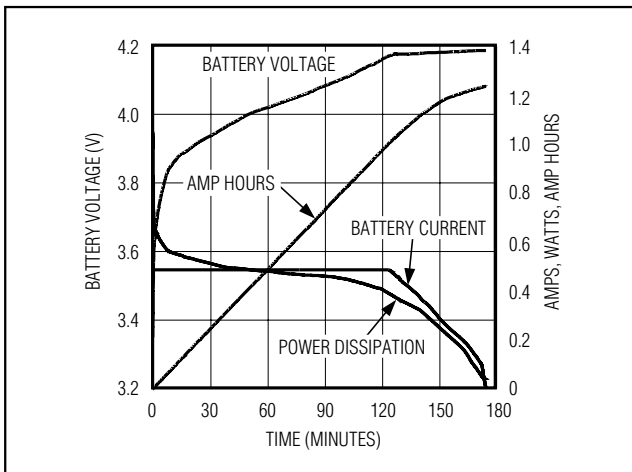

Figure 2. Li+ Charging Profile

the ISET pin is 1mA per amp of charging current. The output voltage at ISET is proportional to charging current as follows:

$$V_{ISET} = \frac{I_{CHG} \times R_{SET}}{1000}$$

The voltage at ISET is nominally 1.4V at the selected fast-charge current, and falls with charging current as the cell becomes fully charged. See Figure 2 for typical Li+ charging profile.

CHG Status Output

\overline{CHG} is an open-drain output that monitors the cell's charging status. \overline{CHG} has a 5mA current limit so an LED can be connected directly from IN to \overline{CHG} for a visible indication. Alternatively, a pullup resistor (typically 100k Ω) to a logic supply provides a logic-level output. Table 1 outlines the status of \overline{CHG} for various charger states.

Table 1. \overline{CHG} Output States

CONDITION	\overline{CHG}
No battery or no charger input.	High impedance (LED off)
The cell voltage is less than 2.5V and charge current is regulated to 10% of the selected fast-charge current (prequalification state).	Low impedance (LED on)
Cell voltage is greater than 2.5V (fast-charge state).	Low impedance (LED on)
Charge cycle complete—charge current is less than 20% of the selected fast charge current or safety timer expires (3 hours for $C_{CT} = 100nF$).	High impedance (LED off)
Charge cycle fault—the cell voltage is less than 2.5V and the prequalification timer (45min for $C_{CT} = 100nF$) has expired.	Blinking, LED on 50% duty factor, 1.5Hz

Reinitiating a Charging Cycle

The MAX1898 can be configured so that a charging cycle automatically restarts when the cell voltage drops 200mV below the battery regulation voltage (connect RSTRT to GND). The restart threshold can also be lowered by connecting an external resistor between RSTRT and GND. If automatic charging restart is not desired, this feature may be disabled by floating the RSTRT pin. With restart disabled, charging can only be reinitiated by pulling EN/OK low, or by removing and reapplying the input power source.

EN/OK (EN Input, OK Output)

The EN/OK pin serves two functions. It primarily serves as a logic input (active high) to enable the charger. In addition to ON/OFF control, EN/OK also indicates when input power is connected. When input power is applied to IN ($V_{IN} > V_{BATT}$ and $V_{IN} > 4.25V$) EN/OK pulls high (to 3V) with a 100k Ω internal pullup resistance. Consequently, EN/OK may be output to a logic input, to indicate AC adapter presence, but at the same time may be driven by open-drain logic to turn the charger ON and OFF. An open-drain logic-low input will over-ride the internal pullup resistor and turn off the charger (see Figure 3). When the open drain goes high impedance, EN/OK will go high if

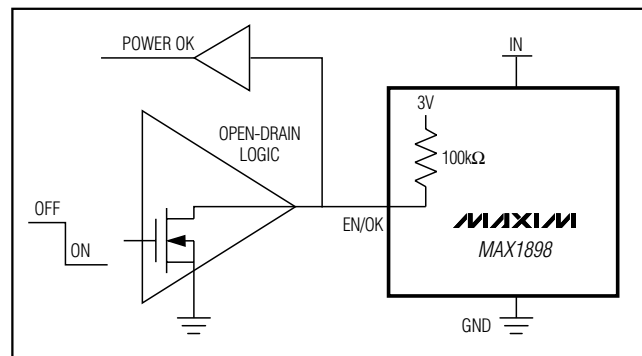

Figure 3. Driving EN/OK with Open-Drain Logic to Retain ON/OFF Control with Power OK Indication

Linear Charger for Single-Cell Li+ Battery

power is present at IN. If there is no (or insufficient) voltage at IN, EN/OK will remain low and the charger will remain off.

Battery Drain Current

The MAX1898 uses advanced CMOS circuitry to completely monitor battery state, while drawing minimal current from the cell itself. When the input voltage is less than the battery, battery drain is typically 3µA. When input power is present and charging is complete (the charge timer expires), battery drain is then typically 40µA. This current may be reduced to 4µA by disabling the restart feature.

Applications Information

The MAX1898 basic application circuit is shown in Figure 4.

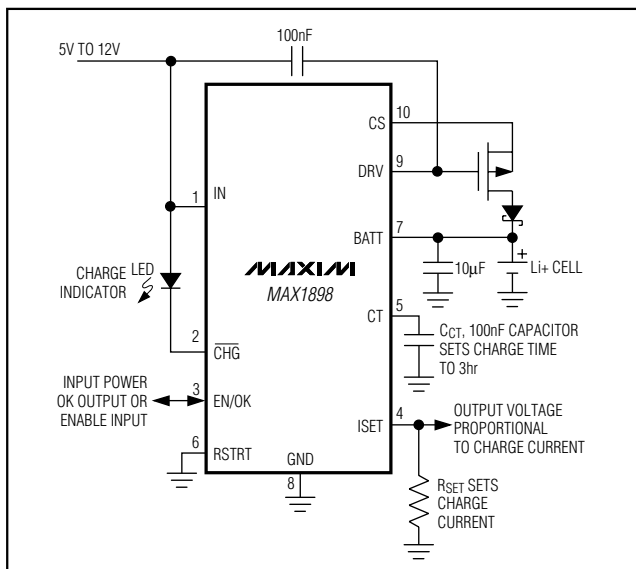

Figure 4. Basic Application Circuit

An LED can be added as a charge-state indicator. A 10µF bypass capacitor must be added to the BATT pin. A Schottky diode should be added between the external transistor drain/collector and BATT, to avoid battery discharge in the event of an input source short circuit.

Figure 5 shows a charger circuit using an external PNP pass transistor.

Selecting Maximum Charge Time

The maximum charge time can be set with an external capacitor connected from CT to GND. Select the timing capacitor using:

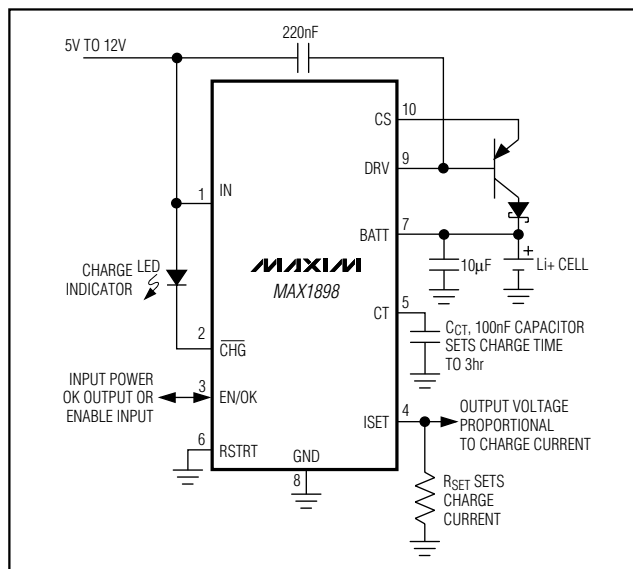

Figure 5. Application Circuit with PNP Pass Transistor

$$C_{CT} [nF] = 34.33 \times t_{CHG} [hours]$$

where:

t_{CHG} = nominal charge time limit in hours.

The maximum charge timer is intended as a safety timer. It is normally not intended to be part of the charge-control loop. When charging a Li+ cell at a 1C rate, normal charge time is approximately 1.5 hours, but this may have wide variations that depend on temperature and cell type. In most cases, 3 hours is recommended for the maximum charge time limit when fast-charging at 1C so that normal-charging is never interrupted by the charge timer. Consult the battery manufacturer for details on recommended timer settings.

The charge safety timer may also be completely disabled by connecting CT to ground. **Note:** If the charge timer is disabled, both the restart function and prequalification fault indication are also disabled. Only the indication (blinking LED) is disabled, the prequalification function itself is not modified.

Controlling Automatic Restart

The MAX1898 features automatic restart that resumes charging when the cell voltage drops to a predetermined level. In most timed chargers, once charging times out, subsequent loading of the battery can discharge the battery and charging will not resume unless the charger is restarted by an outside signal. By automatically resuming charging when the battery voltage drops, the MAX1898 ensures that the cell does not remain partially charged

Linear Charger for Single-Cell Li+ Battery

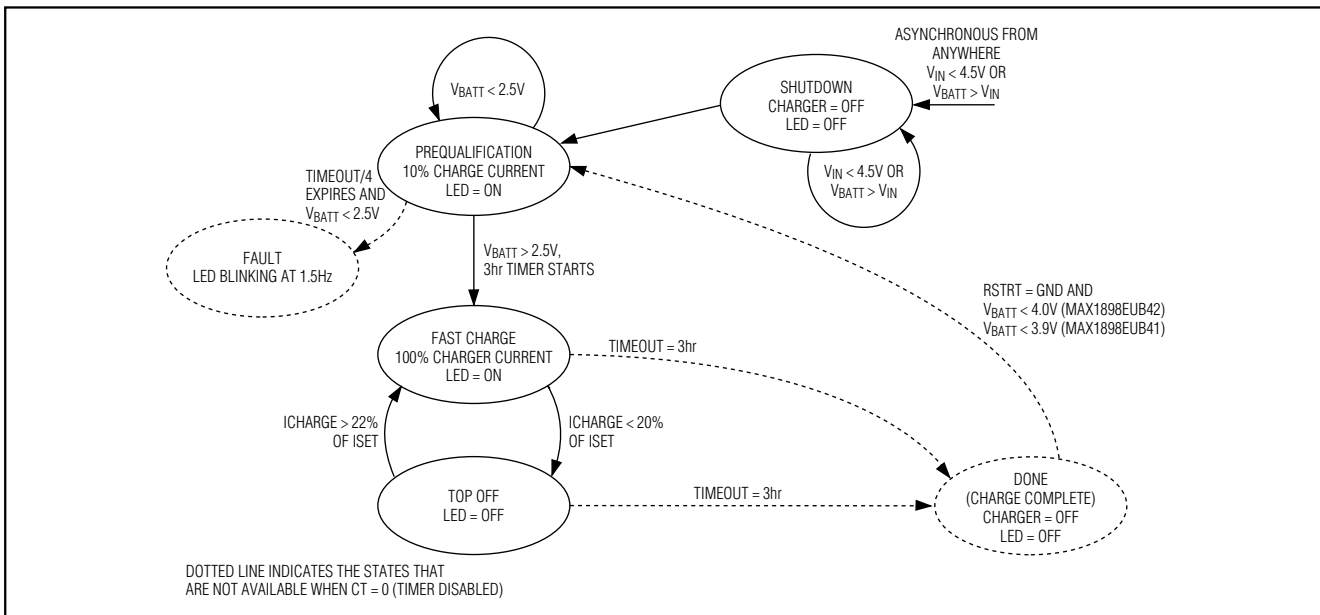

Figure 6. Charger State Diagram

after use when charger power is available. The restart feature can be configured in the following ways:

- Floating the RSTRT pin disables restart. Once the battery is charged and the charge timer expires, charging can only be started by cycling input power to IN, or by toggling EN/OK. When the restart function is disabled, battery drain after charge completion is reduced to 4µA. With the restart function enabled, battery drain current after charge completion is 40µA.
- Ground the RSTRT pin to enable the default restart threshold of 4V for the MAX1898EUB42 and 3.9V for the MAX1898EUB41. Once the battery is charged and the charge timer expires, charging restarts when the cell voltage drops to the restart-threshold voltage.
- If desired, lower the restart-threshold voltage by connecting a resistor from RSTRT to GND. Select the

resistor using the following equations:
For MAX1898EUB42:

$$R_{RSTRT} [k\Omega] = \left[\frac{69.275k\Omega}{\frac{V_{RSTRT}}{1.4V} - 1} \right] - 37.30k\Omega$$

for V_{RSTRT} values between 3V and 4V.

For MAX1898EUB41:

$$R_{RSTRT} [k\Omega] = \left[\frac{66.822k\Omega}{\frac{V_{RSTRT}}{1.4V} - 1} \right] - 37.30k\Omega$$

for V_{RSTRT} values between 3V and 3.9V.

Note that if CT is grounded (charge timer disabled), the restart function is also disabled.

Table 2. External Transistors

EXTERNAL TRANSISTORS	RESISTANCE RATING	VOLTAGE LIMIT (V)	POWER DISSIPATION (W)	PACKAGE	COMMENTS
PMOS Fairchild NDT454P	50mΩ	-30	3	SOT223	—
PNP Zetex FZT968	0.17V, $V_{CE(sat)}$	-15	3	SOT223	$h_{FE} = 300min$
PNP FCX717	0.32V, $V_{CE(sat)}$	-12	1	SOT89	$h_{FE} = 160min$, 1W rating suitable for 0.5A charge or less

Linear Charger for Single-Cell Li+ Battery

Selecting External Components

The MAX1898 drives an external transistor to control charging current. The most important specifications for the pass transistor (MOSFET or bipolar) are current rating and package power dissipation. Since the MAX1898 operates as a linear charger, heat will dissipate in the external transistor. The worst-case power dissipation will be:

$$P_{DISS(MAX)} = I_{FASTCHG} (V_{IN} - 2.5V)$$

The pass transistor and heatsinking (typically an expanded PC board plane) must be rated for $P_{DISS(MAX)}$.

The pass device will most commonly be a P-channel MOSFET. Its operating voltage must exceed the expected input voltage, but MOSFET on-resistance is important only in low-dropout designs where V_{IN} is only slightly higher than the battery regulation voltage. In most charger designs, a fairly low-cost FET (around $100m\Omega$ to $200m\Omega$ $R_{DS(ON)}$) performs more than adequately. Lower resistance FETs perform well also, but are not worth the added cost in this case.

A PNP bipolar transistor may also be used as a pass device. DRV can sink up to 4mA, so reasonable high current gain (h_{FE} or Beta) is required to allow DRV to drive the base of a bipolar pass transistor. For a 500mA fast-charge current, an h_{FE} of 125 is required. Although their current gain is high, Darlington PNP transistors are not recommended due to stability limitations.

If V_{IN} is less than V_{BATT} , the body diode inherent in the external enhancement-mode FET allows current to flow from the cell back to the source. To prevent this, add a Schottky diode between the drain and BATT, as shown in Figure 4.

Chip Information

TRANSISTOR COUNT: 1816

PROCESS: BiCMOS

MAX1898

Linear Charger for Single-Cell Li+ Battery

Package Information

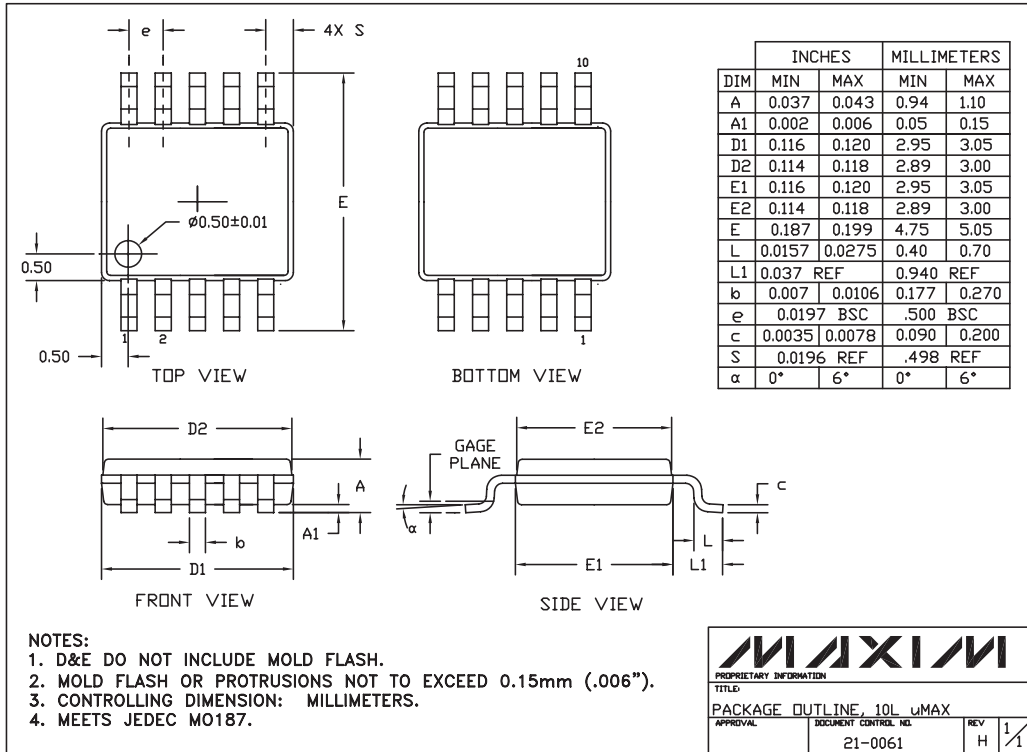

Maxim cannot assume responsibility for use of any circuitry other than circuitry entirely embodied in a Maxim product. No circuit patent licenses are implied. Maxim reserves the right to change the circuitry and specifications without notice at any time.

12 _____ **Maxim Integrated Products, 120 San Gabriel Drive, Sunnyvale, CA 94086 408-737-7600**

Looking for pricing, stock, or lifecycle information?

Click below to explore more details on WIN SOURCE:

- ⊖ [View MAX1898EUB42+ on WIN SOURCE](#)
- ⊖ [Maxim Integrated Information](#)

Optimize Your Supply Chain with WIN SOURCE Solutions

- ✓ Global Sourcing Solution
- ✓ Obsolete Management
- ✓ Cost Control Management
- ✓ Shortage Management
- ✓ Alternative Solution
- ✓ Excess Inventory Management