



**THE DATASHEET OF  
MAX17006ETP+**





# 1.2MHz Low-Cost, High-Performance Chargers

MAX17005/MAX17006/MAX17015

## General Description

The MAX17005/MAX17006/MAX17015 are high-frequency multichemistry battery chargers. These circuits feature a new high-frequency current-mode architecture that significantly reduces component size and cost. The charger uses a high-side MOSFET with n-channel synchronous rectifier. Widely adjustable charge current, charge voltage, and input current limit simplify the construction of highly accurate and efficient chargers.

The charge voltage and charge current are set with analog control inputs. The charge current setting can also be adjusted with a PWM input. High-accuracy current-sense amplifiers provide fast cycle-by-cycle current-mode control to protect against short circuits to the battery and respond quickly to system load transients. In addition, the charger provides a high-accuracy analog output that is proportional to the adapter current. In the MAX17015, this current monitor remains active when the adapter is absent to monitor battery discharge current.

The MAX17005 charges three or four Li+ series cells, and the MAX17006 charges two or three Li+ series cells. The MAX17015 adjusts the charge voltage setting and the number of cells through a feedback resistor-divider from the output. All variants of the charger can provide at least 4A of charge current with a 10mΩ sense resistor.

The charger utilizes a charge pump to control an n-channel adapter selection switch. The charge pump remains active even when the charger is off. When the adapter is absent, a p-channel MOSFET selects the battery.

The MAX17005/MAX17006/MAX17015 are available in a small, 4mm x 4mm x 0.8mm 20-pin, lead-free TQFN package. An evaluation kit is available to reduce design time.

## Applications

Notebook Computers  
Tablet PCs  
Portable Equipment with Rechargeable Batteries

## Features

- ◆ High Switching Frequency (1.2MHz)
- ◆ Controlled Inductor Current-Ripple Architecture  
Reduced BOM Cost  
Small Inductor and Output Capacitors
- ◆ ±0.4% Accurate Charge Voltage
- ◆ ±2.5% Accurate Input-Current Limiting
- ◆ ±3% Accurate Charge Current
- ◆ Single-Point Compensation
- ◆ Monitor Outputs for  
±2.5% Accurate Input Current Limit  
±2.5% Battery Discharge Current  
(MAX17015 only)  
AC Adapter Detection
- ◆ Analog/PWM Adjustable Charge-Current Setting
- ◆ Battery Voltage Adjustable for 3 and 4 Cells  
(MAX17005) or 2 and 3 Cells (MAX17006)
- ◆ Adjustable Battery Voltage (4.2V to 4.4V/Cell)
- ◆ Cycle-by-Cycle Current Limit  
Battery Short-Circuit Protection  
Fast Response for Pulse Charging  
Fast System-Load-Transient Response
- ◆ Programmable Charge Current < 5A
- ◆ Automatic System Power Source Selection with  
n-Channel MOSFET
- ◆ Internal Boost Diode
- ◆ +8V to +26V Input Voltage Range

## Ordering Information

PART	TEMP RANGE	PIN-PACKAGE	PKG CODE
MAX17005ETP+	-40°C to +85°C	20 Thin QFN (4mm x 4mm)	T2044-3
MAX17006ETP+	-40°C to +85°C	20 Thin QFN (4mm x 4mm)	T2044-3
MAX17015ETP+	-40°C to +85°C	20 Thin QFN (4mm x 4mm)	T2044-3

+Denotes a lead-free package.

Pin Configuration and Minimal Operating Circuit appear at end of data sheet.



# 1.2MHz Low-Cost, High-Performance Chargers

## ABSOLUTE MAXIMUM RATINGS

DCIN, CSSP, CSSN, BATT, CSIN, CSIP, $\overline{ACOK}$ , LX to AGND .....-0.3V to +30V	DLO to PGND .....-0.3V to (LDO + 0.3V)
BST to LDO .....-0.3V to +30V	PGND to AGND ..... -0.3V to +0.3V
CSIP to CSIN, CSSP to CSSN .....-0.3V to +0.3V	Continuous Power Dissipation ( $T_A = +70^\circ\text{C}$ ) 16-Pin TQFN (derate 16.9mW/°C above +70°C).....1349.1mW
IINP, FB, ACIN to AGND .....-0.3V to ( $V_{AA} + 0.3\text{V}$ )	Operating Temperature Range .....-40°C to +85°C
$V_{AA}$ , LDO, ISET, VCTL, CC to AGND .....-0.3V to +6V	Junction Temperature .....+150°C
DHI to LX .....-0.3V to (BST + 0.3V)	Storage Temperature Range .....-60°C to +150°C
BST to LX .....-0.3V to +6V	Lead Temperature (soldering, 10s) .....+300°C

Stresses beyond those listed under "Absolute Maximum Ratings" may cause permanent damage to the device. These are stress ratings only, and functional operation of the device at these or any other conditions beyond those indicated in the operational sections of the specifications is not implied. Exposure to absolute maximum rating conditions for extended periods may affect device reliability.

## ELECTRICAL CHARACTERISTICS

(Circuit of Figure 1,  $V_{DCIN} = V_{CSSP} = V_{CSSN} = 19\text{V}$ ,  $V_{BATT} = V_{CSIP} = V_{CSIN} = 16.8\text{V}$ ,  $V_{VCTL} = V_{AA}$ ,  $V_{ISET} = 1\text{V}$ ,  $T_A = 0^\circ\text{C}$  to  $+85^\circ\text{C}$ , unless otherwise noted. Typical values are at  $T_A = +25^\circ\text{C}$ .)

PARAMETER	CONDITIONS	MIN	TYP	MAX	UNITS	
<b>CHARGE-VOLTAGE REGULATION</b>						
Battery Regulation-Voltage Accuracy	2 cells, $V_{VCTL} = \text{GND}$ (for MAX17006)	8.3664	8.40	8.4336	V	
	3 cells, $V_{VCTL} = V_{AA}$ (for MAX17005 and MAX17006)	12.549	12.60	12.651		
	4 cells, $V_{VCTL} = \text{GND}$ (for MAX17005)	16.733	16.80	16.867		
	FB accuracy using FB divider (for MAX17015) (Note 1)	2.0916	2.1	2.1084		
FB Input Bias Current		-1		+1	$\mu\text{A}$	
VCTL Range	2 cells (for MAX17006), 4 cells (for MAX17005)	0.0		$V_{AA}/2$ -0.2	V	
	3 cells (for MAX17005 and MAX17006)	$V_{AA}/2$ +0.2		$V_{AA}$		
VCTL Gain	$V_{CELL}/V_{VCTL}$	5.85	6	6.15	V/V	
VCTL Input Bias Current	$V_{VCTL} = \text{GND}$ and $V_{VCTL} = V_{AA}$	-1		+1	$\mu\text{A}$	
<b>CHARGE-CURRENT REGULATION</b>						
ISET Range		0.0		$V_{AA}/2$	V	
ISET Full-Scale Setting	ISET = 1.4V		80		mV	
	ISET = 99.9% duty cycle		60			
Full-Charge Current Accuracy (CSIP to CSIN)	$V_{BATT} = 1\text{V}$ to $16.8\text{V}$	$V_{ISET} = V_{AA}/4$ or ISET = 99.9% duty cycle	58.2	60	61.8	mV
		$V_{ISET} = V_{AA}/6$ or ISET = 66.7% duty cycle	-3		+3	%
		$V_{ISET} = V_{AA}/80$ or ISET = 5% duty cycle	38.2	40	41.8	mV
Trickle Charge-Current Accuracy	$V_{BATT} = 1\text{V}$ to $16.8\text{V}$	$V_{ISET} = V_{AA}/6$ or ISET = 66.7% duty cycle	-4.5		+4.5	%
		$V_{ISET} = V_{AA}/80$ or ISET = 5% duty cycle	1.4	3	4.6	mV
Charge-Current Gain Error	Based on $V_{ISET} = V_{AA}/4$ and $V_{ISET} = V_{AA}/80$	-2		+2	%	
Charge-Current Offset Error	Based on $V_{ISET} = V_{AA}/4$ and $V_{ISET} = V_{AA}/80$	-1.4		+1.4	mV	
BATT/CSIP/CSIN Input Voltage Range		0		24	V	
ISET Power-Down Mode Threshold	ISET falling	21	26	31	mV	
	ISET rising	33	40	47		

# 1.2MHz Low-Cost, High-Performance Chargers

MAX17005/MAX17006/MAX17015

## ELECTRICAL CHARACTERISTICS (continued)

(Circuit of Figure 1,  $V_{DCIN} = V_{CSSP} = V_{CSSN} = 19V$ ,  $V_{BATT} = V_{CSIP} = V_{CSIN} = 16.8V$ ,  $V_{VCTL} = V_{AA}$ ,  $V_{ISET} = 1V$ ,  $T_A = 0^\circ C$  to  $+85^\circ C$ , unless otherwise noted. Typical values are at  $T_A = +25^\circ C$ .)

PARAMETER	CONDITIONS	MIN	TYP	MAX	UNITS
ISET Input Bias Current	$V_{ISET} = 3V$	-0.2		+0.2	$\mu A$
	$CSSN = BATT$ , $V_{ISET} = 5V$	-0.2		+0.2	
ISET PWM Threshold	Rising			2.4	V
	Falling	0.8			
ISET Frequency		0.128		500	kHz
ISET Effective Resolution	$f_{PWM} = 3.2MHz$		8		Bits
<b>INPUT-CURRENT REGULATION</b>					
Input Current-Limit Threshold	$V_{CSSP} - V_{CSSN}$	58.5	60	61.5	mV
		-2.5		+2.5	%
CSSN Input Bias Current	Adapter present	-0.1		+0.1	$\mu A$
CSSP/CSSN Input-Voltage Range		8.0		26.0	V
IINP Transconductance	$V_{CSSP} - V_{CSSN} = 60mV$	2.66	2.8	2.94	$\mu A/mV$
IINP Accuracy	$V_{CSSP} - V_{CSSN} = 60mV$ , $V_{IINP} = 0V$ to $4.5V$	-2.5		+2.5	%
	$V_{CSSP} - V_{CSSN} = 35mV$	-2.5		+2.5	
<b>SUPPLY AND LINEAR REGULATOR</b>					
DCIN Input Voltage Range		8		26	V
DCIN Undervoltage-Lockout (UVLO) Trip-Point	DCIN falling	7.9	8.1		V
	DCIN rising		8.7	8.9	
DCIN + CSSP + CSSN Quiescent Current	Adapter present (Note 2)		3	6	mA
	Adapter absent (Note 2)		30	50	
BATT + CSIP + CSIN + LX Input Current	$V_{BATT} = 16.8V$	Adapter absent (Note 2)	10	20	$\mu A$
		Charger shutdown (Note 2)	10	20	
	$V_{BATT} = 2V$ to $19V$ , adapter present (Note 2)	200	500		
LDO Output Voltage	$8.0V < V_{DCIN} < 26V$ , no load	5.15	5.35	5.55	V
LDO Load Regulation	$0 < I_{LDO} < 40mA$		100	200	mV
LDO UVLO Threshold		3.2	4.1	5.0	V
<b>REFERENCES</b>					
$V_{AA}$ Output Voltage	$I_{VAA} = 50\mu A$	4.18	4.20	4.22	V
$V_{AA}$ UVLO Threshold	$V_{AA}$ falling		3.1	3.9	V
<b>ACIN</b>					
ACIN Threshold		2.058	2.1	2.142	V
ACIN Threshold Hysteresis		10	20	30	mV
ACIN Input Bias Current		-1		+1	$\mu A$
<b>ACOK</b>					
$\overline{ACOK}$ Sink Current	$V_{\overline{ACOK}} = 0.4V$ , $V_{ACIN} = 1.5V$	6			mA
$\overline{ACOK}$ Leakage Current	$V_{\overline{ACOK}} = 5.5V$ , $V_{ACIN} = 2.5V$			1	$\mu A$

# 1.2MHz Low-Cost, High-Performance Chargers

## ELECTRICAL CHARACTERISTICS (continued)

(Circuit of Figure 1,  $V_{DCIN} = V_{CSP} = V_{SSN} = 19V$ ,  $V_{BATT} = V_{CSIP} = V_{CSIN} = 16.8V$ ,  $V_{VCTL} = V_{AA}$ ,  $V_{ISET} = 1V$ ,  $T_A = 0^{\circ}C$  to  $+85^{\circ}C$ , unless otherwise noted. Typical values are at  $T_A = +25^{\circ}C$ .)

PARAMETER	CONDITIONS	MIN	TYP	MAX	UNITS
<b>SWITCHING REGULATOR</b>					
DHI Off-Time K Factor	$V_{DCIN} = 19V$ , $V_{BATT} = 10V$	0.029	0.030	0.041	$\mu s/V$
Sense Voltage for Minimum Discontinuous Mode Ripple Current	$V_{CSIP} - V_{CSIN}$		10		mV
Zero-Crossing Comparator Threshold	$V_{CSIP} - V_{CSIN}$		10		mV
Cycle-by-Cycle Current-Limit Sense Voltage	$V_{CSIP} - V_{CSIN}$	105	110	115	mV
DHI Resistance High	$I_{DLO} = 10mA$		1.5	3	$\Omega$
DHI Resistance Low	$I_{DLO} = -10mA$		0.8	1.75	$\Omega$
DLO Resistance High	$I_{DLO} = 10mA$		3	6	$\Omega$
DLO Resistance Low	$I_{DLO} = -10mA$		3	7	$\Omega$
<b>ADAPTER DETECTION</b>					
Adapter Absence-Detect Threshold	$V_{DCIN} - V_{BATT}$ , $V_{DCIN}$ falling	+70	+120	+170	mV
Adapter Detect Threshold	$V_{DCIN} - V_{BATT}$ , $V_{DCIN}$ rising	+360	+420	+580	mV
Adapter Switch Charge-Pump Frequency	Charger Shutdown	180	200	220	Hz
Adapter Switch Charge-Pump Refresh Pulse	DLO	0.04	0.1	0.20	$\mu s$
	DHI	0.07	0.15	0.30	

## ELECTRICAL CHARACTERISTICS

(Circuit of Figure 1,  $V_{DCIN} = V_{CSP} = V_{SSN} = 19V$ ,  $V_{BATT} = V_{CSIP} = V_{CSIN} = 16.8V$ ,  $V_{VCTL} = V_{AA}$ ,  $V_{ISET} = 1V$ ,  $T_A = -40^{\circ}C$  to  $+85^{\circ}C$ , unless otherwise noted.)

PARAMETER	CONDITIONS	MIN	TYP	MAX	UNITS
<b>CHARGE-VOLTAGE REGULATION</b>					
Battery Regulation-Voltage Accuracy	2 cells, $V_{VCTL} = GND$ (for MAX17006)	8.366		8.433	V
	3 cells, $V_{VCTL} = V_{AA}$ (for MAX17005 and MAX17006)	12.549		12.651	
	4 cells, $V_{VCTL} = GND$ (for MAX17005)	16.73		16.86	
	FB accuracy using FB divider (for MAX17015) (Note 1)	2.091		2.108	
VCTL Range	2 cells (for MAX17006), 4 cells (for MAX17005)	0.0		$V_{AA}/2$ - 0.2	V
	3 cells (for MAX17005 and MAX17006)	$V_{AA}/2$ + 0.2		$V_{AA}$	
VCTL Gain	$V_{CELL}/V_{VCTL}$	5.85		6.15	V/V

# 1.2MHz Low-Cost, High-Performance Chargers

MAX17005/MAX17006/MAX17015

## ELECTRICAL CHARACTERISTICS (continued)

(Circuit of Figure 1,  $V_{DCIN} = V_{CSSP} = V_{CSSN} = 19V$ ,  $V_{BATT} = V_{CSIP} = V_{CSIN} = 16.8V$ ,  $V_{VCTL} = V_{AA}$ ,  $V_{ISET} = 1V$ ,  $T_A = -40^{\circ}C$  to  $+85^{\circ}C$ , unless otherwise noted.)

PARAMETER	CONDITIONS		MIN	TYP	MAX	UNITS
<b>CHARGE-CURRENT REGULATION</b>						
ISET Range			0.0		$V_{AA}/2$	V
Full Charge-Current Accuracy (CSIP to CSIN)	$V_{BATT} = 1V$ to $16.8V$	$V_{ISET} = V_{AA}/4$ or ISET = 99.9% duty cycle	57.5		62.5	mV
			-4.2		+4.2	%
$V_{ISET} = V_{AA}/6$ or ISET = 66.7% duty cycle		38		42	mV	
		-5		+5	%	
Trickle Charge-Current Accuracy		$V_{ISET} = V_{AA}/80$ or ISET = 5% duty cycle	1.4		4.6	mV
			-52		+52	%
Charge-Current Gain Error	Based on $V_{ISET} = V_{AA}/4$ and $V_{ISET} = V_{AA}/80$		-2		+2	%
Charge-Current Offset Error	Based on $V_{ISET} = V_{AA}/4$ and $V_{ISET} = V_{AA}/80$		-1.4		+1.4	mV
BATT/CSIP/CSIN Input Voltage Range			0		24	V
ISET Power-Down Mode Threshold	ISET falling		21		31	mV
	ISET rising		33		47	
ISET PWM Threshold	Rising				2.4	V
	Falling		0.8			
ISET Frequency			0.128		500	kHz
<b>INPUT-CURRENT REGULATION</b>						
Input Current-Limit Threshold	$V_{CSSP} - V_{CSSN}$		58.2		61.8	mV
			-3		+3	%
CSSN Input Bias Current	Adapter present		-2		+2	$\mu A$
CSSP/CSSN Input-Voltage Range			8.0		26.0	V
IINP Transconductance	$V_{CSSP} - V_{CSSN} = 60mV$		2.66		2.94	$\mu A/mV$
IINP Accuracy	$V_{CSSP} - V_{CSSN} = 60mV$ , $V_{IINP} = 0V$ to $4.5V$		-2.5		+2.5	%
	$V_{CSSP} - V_{CSSN} = 35mV$		-2.5		+2.5	
<b>SUPPLY AND LINEAR REGULATOR</b>						
DCIN Input-Voltage Range			8		26	V
DCIN UVLO Trip-Point	DCIN falling		7.9			V
	DCIN rising				8.9	
DCIN + CSSP + CSSN Quiescent Current	Adapter present (Note 2)				6	mA
	Adapter absent (Note 2)				50	
BATT + CSIP + CSIN + LX Input Current	$V_{BATT} = 16.8V$	Adapter absent (Note 2)			20	$\mu A$
		Charger shutdown (Note 2)			20	
	$V_{BATT} = 2V$ to $19V$ , adapter present (Note 2)				500	
LDO Output Voltage	$8.0V < V_{DCIN} < 26V$ , no load		5.15		5.55	V
LDO Load Regulation	$0 < I_{LDO} < 40mA$				200	mV
LDO UVLO Threshold			3.2		5.0	V

# 1.2MHz Low-Cost, High-Performance Chargers

## ELECTRICAL CHARACTERISTICS (continued)

(Circuit of Figure 1,  $V_{DCIN} = V_{CSSP} = V_{CSSN} = 19V$ ,  $V_{BATT} = V_{CSIP} = V_{CSIN} = 16.8V$ ,  $V_{VCTL} = V_{AA}$ ,  $V_{ISET} = 1V$ ,  $T_A = -40^{\circ}C$  to  $+85^{\circ}C$ , unless otherwise noted.)

PARAMETER	CONDITIONS	MIN	TYP	MAX	UNITS
<b>REFERENCES</b>					
VAA Output Voltage	$I_{VAA} = 50\mu A$	4.18		4.22	V
VAA UVLO Threshold	$V_{AA}$ falling			3.9	V
<b>ACIN</b>					
ACIN Threshold		2.058		2.142	V
ACIN Threshold Hysteresis		10		30	mV
<b>ACOK</b>					
ACOK Sink Current	$V_{ACOK} = 0.4V$ , $V_{ACIN} = 1.5V$	6			mA
<b>SWITCHING REGULATOR</b>					
DHI Off-Time K Factor	$V_{DCIN} = 19V$ , $V_{BATT} = 10V$	0.029		0.041	$\mu s/V$
Cycle-by-Cycle Current-Limit Sense Voltage	$V_{CSIP} - V_{CSIN}$	105		115	mV
DHI Resistance High	$I_{DLO} = 10mA$			3	$\Omega$
DHI Resistance Low	$I_{DLO} = -10mA$			1.75	$\Omega$
DLO Resistance High	$I_{DLO} = 10mA$			6	$\Omega$
DLO Resistance Low	$I_{DLO} = -10mA$			7	$\Omega$
<b>ADAPTER DETECTION</b>					
Adapter Absence-Detect Threshold	$V_{DCIN} - V_{BATT}$ , $V_{DCIN}$ falling	+70		+170	mV
Adapter Detect Threshold	$V_{DCIN} - V_{BATT}$ , $V_{DCIN}$ rising	+320		+620	mV
Adapter Switch Charge-Pump Frequency		180		220	Hz
Adapter Switch Charge-Pump Refresh Pulse	DLO	0.04		0.2	$\mu s$
	DHI	0.07		0.3	

**Note 1:** Accuracy does not include errors due to external resistance tolerances.

**Note 2:** Adapter present conditions are tested at  $V_{DCIN} = 19V$  and  $V_{BATT} = 16.8V$ . Adapter absent conditions are tested at  $V_{DCIN} = 16V$ ,  $V_{BATT} = 16.8V$ .

# 1.2MHz Low-Cost, High-Performance Chargers

## Typical Operating Characteristics

(Circuit of Figure 1, adapter = 19V, battery = 10V, ISET = 1.05V, V<sub>CTL</sub> = GND, T<sub>A</sub> = +25°C, unless otherwise noted.)

MAX17005/MAX17006/MAX17015

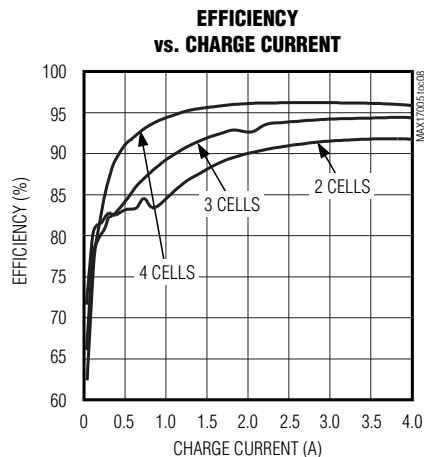
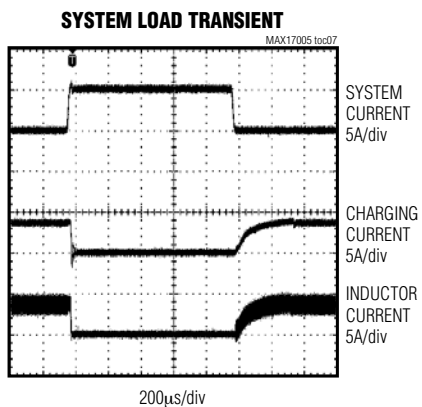
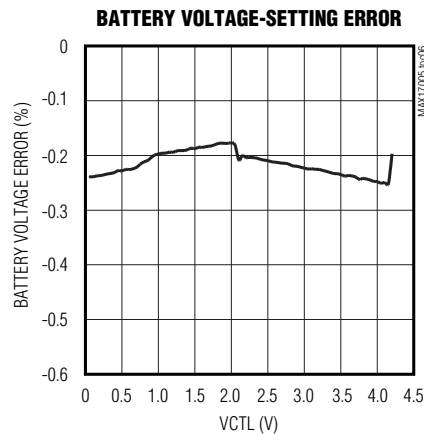
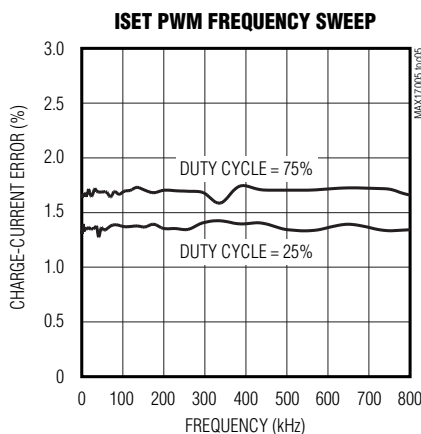
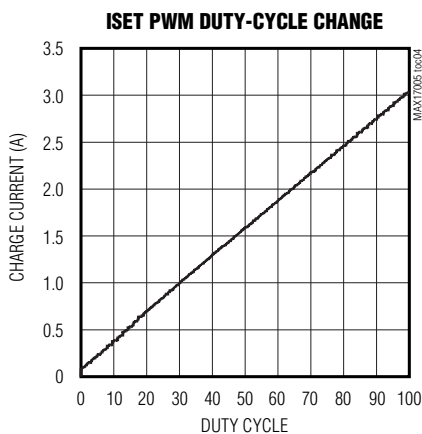
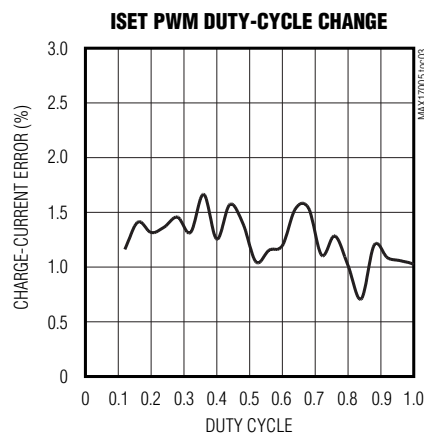
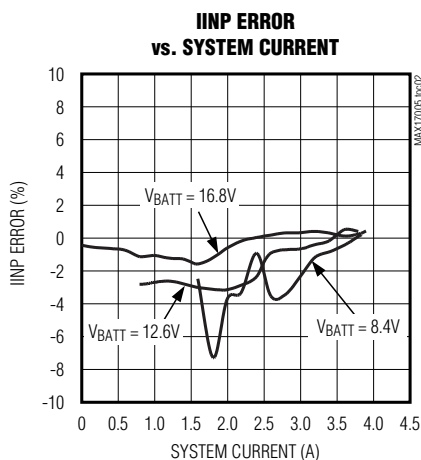
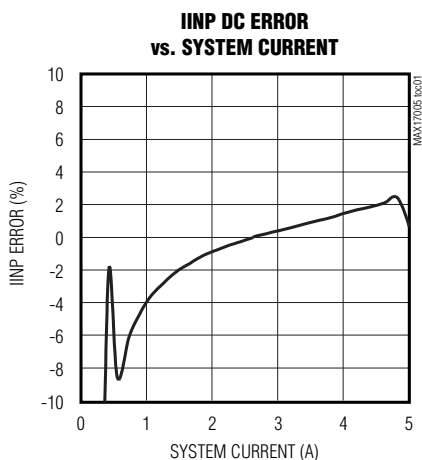

# 1.2MHz Low-Cost, High-Performance Chargers

## Typical Operating Characteristics (continued)

(Circuit of Figure 1, adapter = 19V, battery = 10V, ISET = 1.05V,  $V_{CTL} = GND$ ,  $T_A = +25^\circ C$ , unless otherwise noted.)

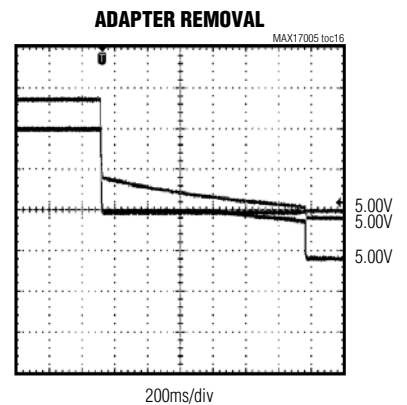
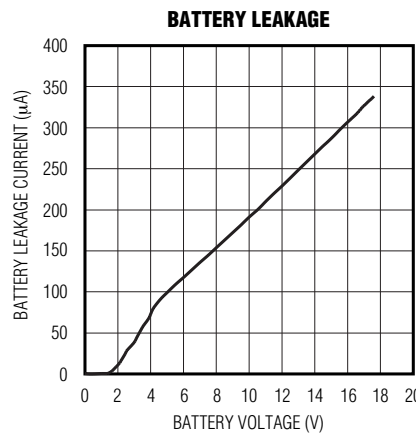
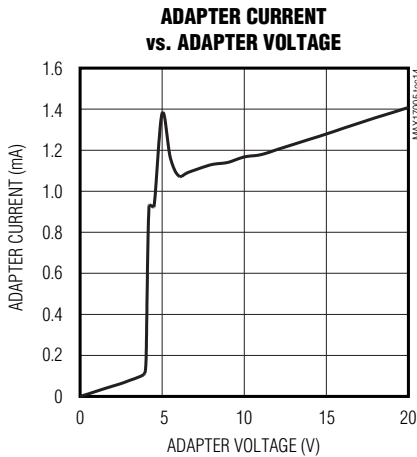
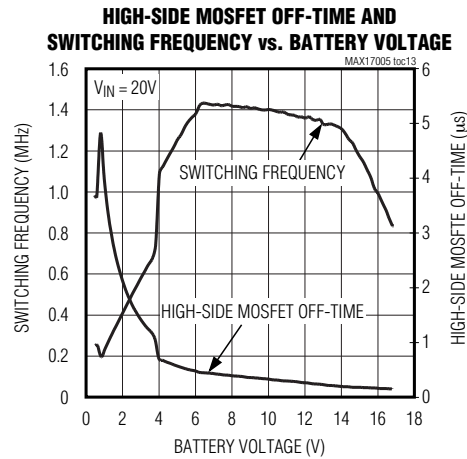
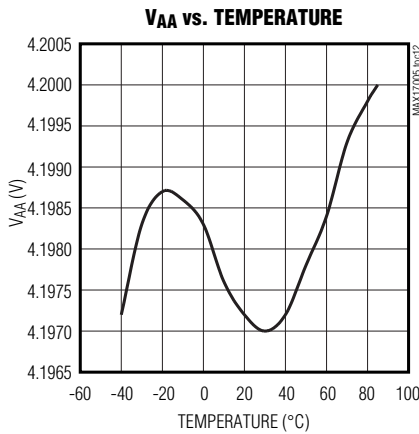
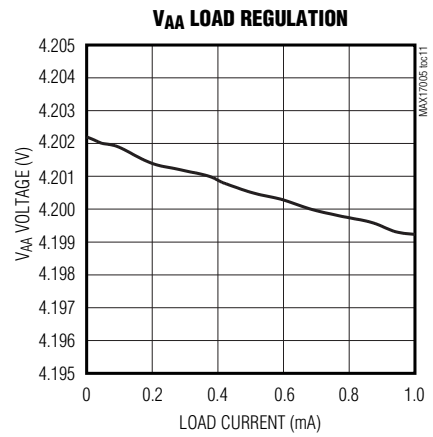
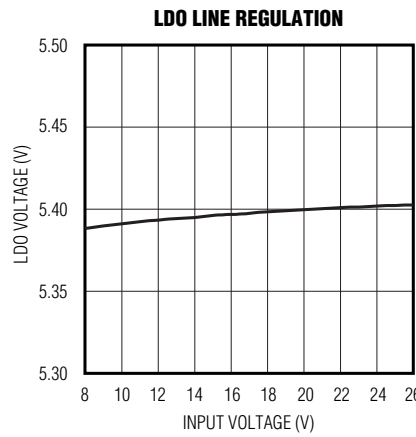
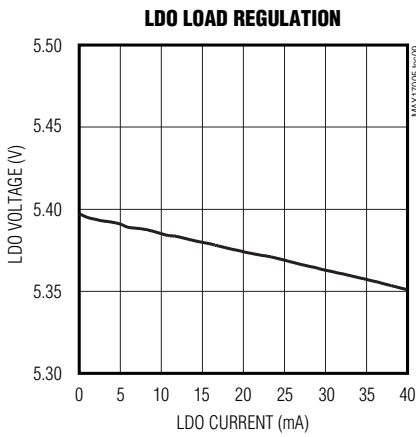

# 1.2MHz Low-Cost, High-Performance Chargers

## Pin Description

PIN	NAME	FUNCTION
1	DCIN	Charger Bias Supply Input. Bypass DCIN with a 1 $\mu$ F capacitor to PGND.
2	AGND	Analog Ground
3	CSIP	Output Current-Sense Positive Input. Connect a current-sense resistor from CSIP to CSIN.
4	CSIN	Output Current-Sense Negative Input
5	IINP	Input Current-Monitor Output. IINP sources the current proportional to the current sensed across CSSP and CSSN. The transconductance from (CSSP - CSSN) to IINP is 2.8 $\mu$ A/mV. See the <i>Analog Input Current-Monitor Output</i> section to configure the current monitor for a particular gain setting.
6	BATT	Battery Voltage Feedback Input
7	$\overline{\text{ACOK}}$	AC Detect Output. This open-drain output is high impedance when ACIN is lower than $V_{AA}/2$ . Connect a 10k $\Omega$ pullup resistor from LDO to $\overline{\text{ACOK}}$ .
8	CSSP	Input Current Sense for Positive Input. Connect a current-sense resistor from CSSP to CSSN.
9	CSSN	Input Current-Sense Negative Input
10	ISET	Dual Mode™ Input for Setting Maximum Charge Current. ISET can be configured either with a resistor voltage-divider or with a PWM signal from 128Hz to 500kHz. If there is no clock edge within 20ms, ISET defaults to analog input mode. Pull ISET to GND to shut down the charger.  In the MAX17015, when the adapter is absent, drive ISET above 1V to enable IINP during battery discharge. When the adapter is reinserted, ISET must be released to the correct control level within 300ms.
11	PGND	Power Ground Connection for MOSFET Drivers
12	DLO	Low-Side Power-MOSFET Driver Output. Connect to low-side n-channel MOSFET gate.
13	LDO	Linear Regulator Output. LDO provides the power to the MOSFET drivers. LDO is the output of the 5.4V linear regulator supplied from DCIN. Bypass LDO with a 4.7 $\mu$ F ceramic capacitor from LDO to PGND.
14	BST	High-Side Driver Supply. Connect a 0.68 $\mu$ F capacitor from BST to LX.
15	DHI	High-Side Power-MOSFET Driver Output. Connect to high-side n-channel MOSFET gate.
16	LX	High-Side Driver Source Connection. Connect a 0.68 $\mu$ F capacitor from BST to LX.
17	ACIN	AC Adapter Detect Input. ACIN is the input to an uncommitted comparator.
18	V <sub>AA</sub>	4.2V Voltage Reference and Device Power-Supply Input. Bypass V <sub>AA</sub> with a 1 $\mu$ F capacitor to GND.
19	CC	Voltage Regulation Loop-Compensation Point. Connect 3k $\Omega$ and 0.01 $\mu$ F capacitor in series from CC to GND.
20	VCTL	Battery Voltage Adjust Input. VCTL sets the number of cells and adjusts the voltage per cell. The adjustment range is 4.2V to 4.4V per cell. See the <i>Setting Charge Voltage</i> section.
—	BP	Backside Paddle. Connect the backside paddle to analog ground.

MAX17005/MAX17006/MAX17015

Dual Mode is a trademark of Maxim Integrated Products, Inc.

# 1.2MHz Low-Cost, High-Performance Chargers

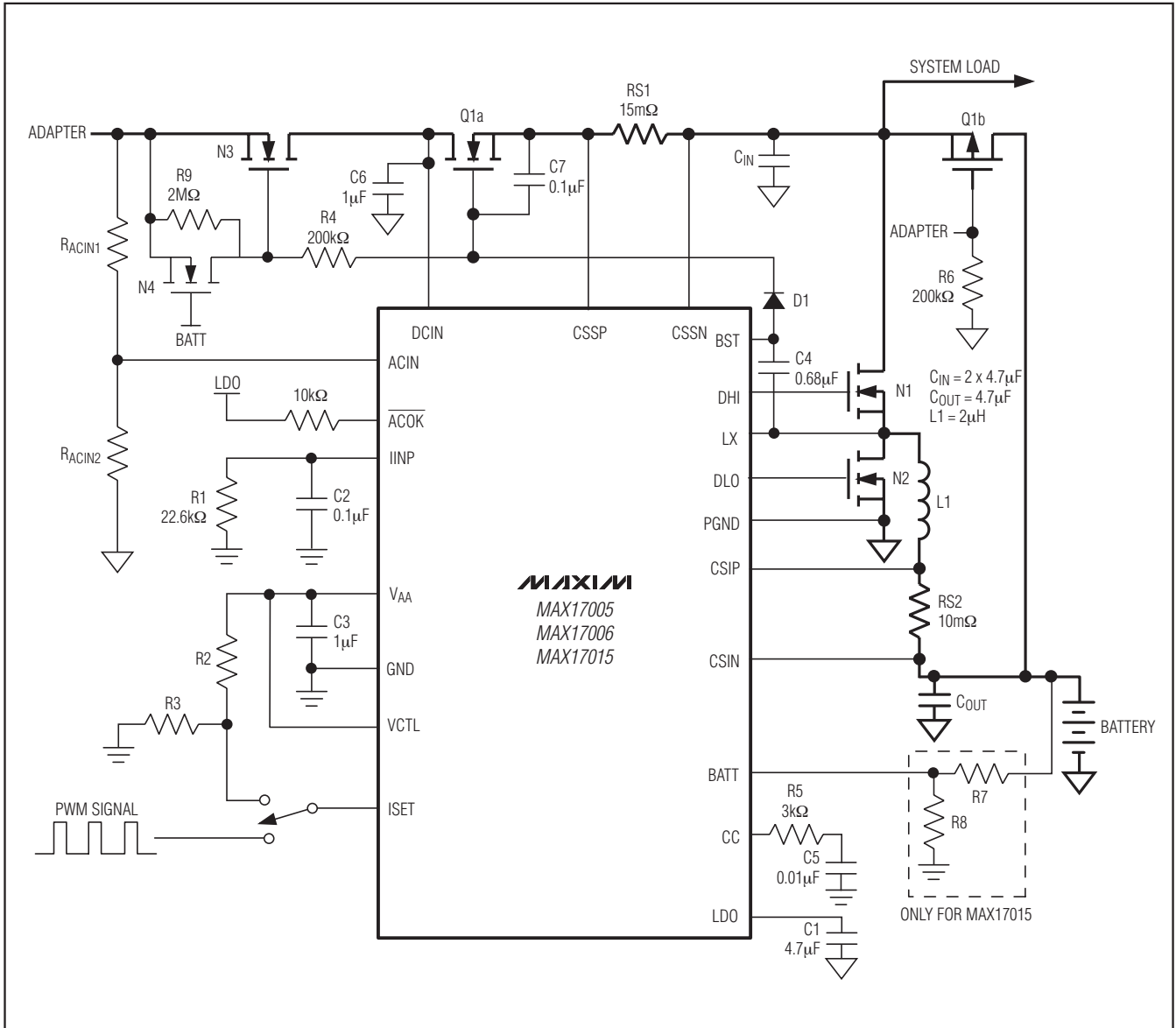

Figure 1. Typical Operating Circuit

## Detailed Description

The MAX17005/MAX17006/MAX17015 include all the functions necessary to charge Li+, NiMH, and NiCd batteries. An all n-channel synchronous-rectified step-down DC-DC converter is used to implement a precision constant-current, constant-voltage charger. The charge current and input current-limit sense amplifiers have low-input offset errors (250 $\mu$ V typ), allowing the use of small-valued sense resistors.

The MAX17005/MAX17006/MAX17015 use a new thermally optimized high-frequency architecture. With this new architecture, the switching frequency is adjusted to control the power dissipation in the high-side MOSFET. Benefits of the new architecture include: reduced output capacitance and inductance, resulting in smaller printed-circuit board (PCB) area and lower cost.

# 1.2MHz Low-Cost, High-Performance Chargers

MAX17005/MAX17006/MAX17015

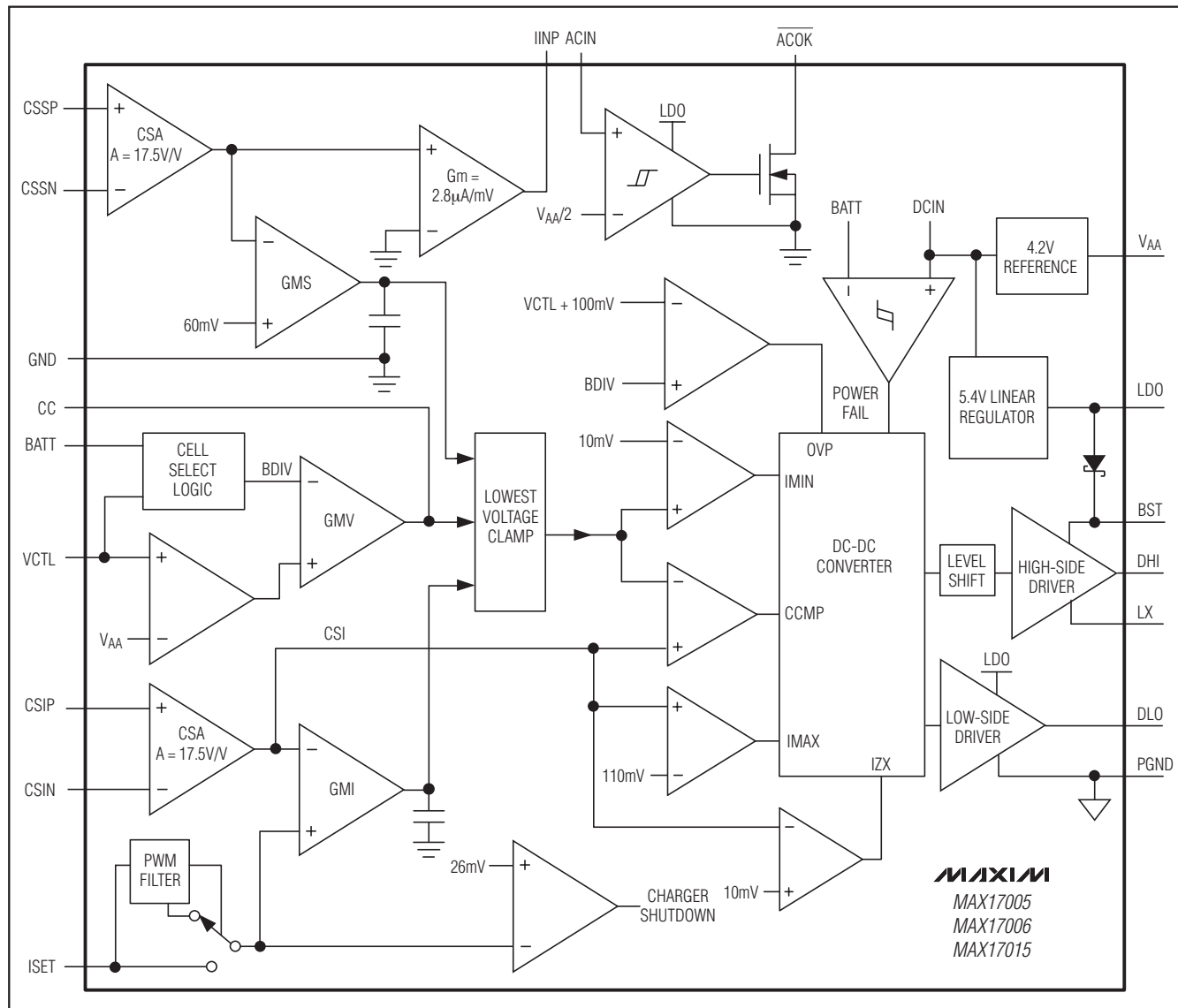

Figure 2. Functional Diagram

The MAX17005/MAX17006/MAX17015 feature a voltage-regulation loop (CCV) and two current-regulation loops (CCI and CCS). The loops operate independently of each other. The CCV voltage-regulation loop monitors BATT to ensure that its voltage never exceeds the voltage set by VCTL. The CCI battery charge current-regulation loop monitors current delivered to BATT to ensure that it never exceeds the current limit set by ISET. The charge current-regulation loop is in control as long as the battery voltage is below the set point. When the battery voltage reaches its set point, the voltage-

regulation loop takes control and maintains the battery voltage at the set point. A third loop (CCS) takes control and reduces the charge current when the adapter current exceeds the input current limit.

The MAX17005/MAX17006/MAX17015 have single-point compensation. The two current loops are internally compensated while the voltage loop is compensated with a series RC network at CC pin. See the *CC Loop Compensation* section for the resistor and capacitor selection. A functional diagram is shown in Figure 2.

# 1.2MHz Low-Cost, High-Performance Chargers

## Setting Charge Voltage

The VCTL input adjusts the battery-output voltage, VBATT, and determines the number of cells. For 3- and 4-cell applications, use the MAX17005; for 2- and 3-cell applications, use the MAX17006. Use the MAX17015 to adjust the cell number and set the cell voltage with a resistive voltage-divider from the output. Based on the version of the part, the number of cells and the level of VCTL should be set as in Table 1:

**Table 1. Cell Configuration**

VERSION	NO. OF CELLS	LEVEL
MAX17005	3	2.4V < VCTL < 4.2V
MAX17005	4	0V < VCTL < 1.8V
MAX17006	2	0V < VCTL < 1.8V
MAX17006	3	2.4V < VCTL < 4.2V
MAX17015	Sets FB	VCTL = GND or VCTL = VAA

The MAX17005 and MAX17006 support from 4.2V/cell to 4.4V/cell, whereas the MAX17015 supports minimum 2.1V. The maximum voltage is determined with the dropout performance of IC. When the required voltage falls outside the range available with the MAX17005 or MAX17006, the MAX17015 should be used.

The charge-voltage regulation for the MAX17005 and MAX17006 is calculated with the following equations:

$$V_{CELL} = 4.2V + \frac{4.2V - V_{VCTL}}{6}$$

for 3-cell selection of MAX17005 and MAX17006, 4.2V > VCTL > 2.4V:

$$V_{CELL} = 4.2V + \frac{V_{VCTL}}{6}$$

for 2- or 4-cell selection of MAX17006 or MAX17005, respectively, 0V < VCTL < 1.8V. Connect VCTL to GND or to VAA for default 4.2V/cell battery-voltage setting.

For the MAX17015, connect VCTL to GND to set the FB regulation point to 2.1V. The charge-voltage regulation is calculated with the following equation:

$$V_{CHG\_REG} = V_{FB\_SETPOINT} \times \frac{R8 + R7}{R8}$$

There are two constraints in choosing R7 and R8. The resistors cannot be too small since they discharge the battery, and they cannot be too large because FB pin consumes less than 1µA of input bias current. Pick R8 to be approximately 10kΩ and then calculate R7.

FB regulation error (±0.5% max) and the tolerance of R7 and R8 both contribute to the error on the battery voltage. Use 0.1% feedback resistors for best accuracy.

## Setting Charge Current

The voltage at ISET determines the voltage across current-sense resistor RS2. ISET can accept either analog or digital inputs. The full-scale differential voltage between CSIP and CSIN is 80mV (8A for RS2 = 10mΩ) for the analog input, and 60mV (6A for RS2 = 10mΩ) for the digital PWM input.

When the MAX17005/MAX17006/MAX17015 power up and the charger is ready, if there is no clock edge within 20ms, the circuit assumes ISET is an analog input, and disables the PWM filter block. To configure the charge current, force the voltage on ISET according to the following equation:

$$I_{CHG} = \frac{240mV}{RS2} \times \frac{V_{ISET}}{V_{AA}}$$

The input range for ISET is from 0 to VAA/2. To shut down the charger, pull ISET below 26mV.

If there is a clock edge on ISET within 20ms, the PWM filter is enabled and ISET accepts digital PWM input. The PWM filter has a DAC with 8-bit resolution that corresponds to equivalent VCSIP-CSIN steps.

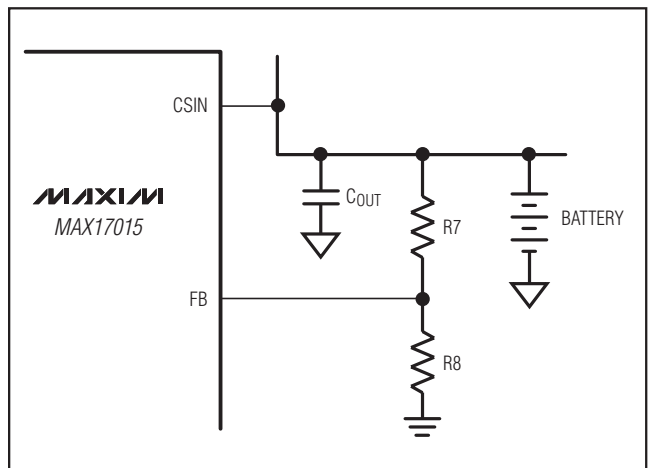

Figure 3. MAX17015 Charge-Voltage Regulation Feedback Network

# 1.2MHz Low-Cost, High-Performance Chargers

The PWM filter accepts the digital signal with a frequency from 128Hz to 500kHz. Zero duty cycle shuts down the MAX17005/MAX17006/MAX17015, and 99.5% duty cycle corresponds to full scale (60mV) across CSIP and CSIN.

Choose a current-sense resistor (RS2) to have a sufficient power-dissipation rating to handle the full-charge current. The current-sense voltage can be reduced to minimize the power-dissipation period. However, this can degrade accuracy due to the current-sense amplifier's input offset (0.25mV typ). See *Typical Operating Characteristics* to estimate the charge-current accuracy at various set points.

### Setting Input-Current Limit

The total input current, from a wall adapter or other DC source, is the sum of the system supply current and the current required by the charger. When the input current exceeds the set input-current limit, the controller decreases the charge current to provide priority to system load current. System current normally fluctuates as portions of the system are powered up or down. The input-current-limit circuit reduces the power requirement of the AC wall adapter, which reduces adapter cost. As the system supply rises, the available charge current drops linearly to zero. Thereafter, the total input current can increase without limit.

The total input current is the sum of the device supply current, the charger input current, and the system load current. The total input current can be estimated as follows:

$$I_{\text{INPUT}} = I_{\text{LOAD}} + \frac{I_{\text{CHARGE}} \times V_{\text{BATTERY}}}{V_{\text{IN}} \times \eta}$$

where  $\eta$  is the efficiency of the DC-to-DC converter (typically 85% to 95%).

In the MAX17005/MAX17006/MAX17015, the voltage across CSSP and CSSN is constant at 60mV. Choose the current-sense resistor, RS1, to set the input current limit. For example, for 4A input current limit, choose RS1 = 15mΩ. For the input current-limit settings, which cannot be achievable with standard sense resistor values, use a resistive voltage-divider between CSSP and CSSN to tune the setting (Figure 4).

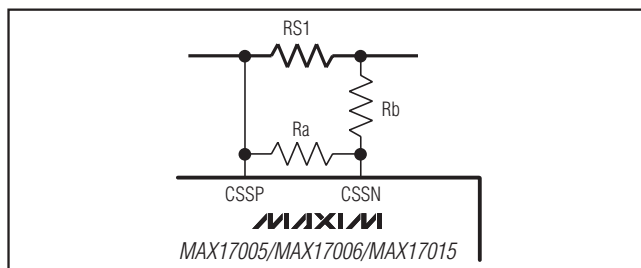

Figure 4. Input Current-Limit Fine Tuning

$$I_{\text{INPUT\_LIMIT}} = \frac{60\text{mV}}{RS1} \times \left(1 + \frac{Rb}{Ra}\right)$$

To minimize power dissipation, first choose RS1 according to the closest available value. For convenience, choose Ra = 6kΩ and calculate Rb from the above equation.

Choose a current-sense resistor (RS1) to have a sufficient power rating to handle the full system current. The current-sense resistor can be reduced to improve efficiency, but this degrades accuracy due to the current-sense amplifier's input offset (0.15mV typ). See *Typical Operating Characteristics* to estimate the input current-limit accuracy at various set points.

### Automatic Power-Source Selection

The MAX17005/MAX17006/MAX17015 use an external charge pump to drive the gate of an n-channel adapter selection switch (N3 and Q1a). In Figure 1, when the adapter is present, BST is biased 5V above VADAPTER so that N3 and Q1a are on, and Q1b is off. As long as the adapter is present, even though the charger is off, the power stage forces a refresh pulse to the BST charge pump every 5ms.

When the adapter voltage is removed, the charger stops generating BST refresh pulses and N4 forces N2 off, Q1b turns on and supplies power to the system from the battery.

In Figure 1, D1 must have low forward-voltage drop and low reverse-leakage current to ensure sufficient gate drive at N3 and Q1a. A 100mA, low reverse-leakage Schottky diode is the right choice.

### Analog Input Current-Monitor Output

Use IINP to monitor the system-input current, which is sensed across CSSP and CSSN. The voltage at IINP is proportional to the input current:

$$I_{\text{INPUT}} = \frac{V_{\text{IINP}}}{RS1 \times G_{\text{IINP}} \times R_{\text{IINP}}}$$

where  $I_{\text{INPUT}}$  is the DC current supplied by the AC adapter,  $G_{\text{IINP}}$  is the transconductance of the sense amplifier (2.8 mA/V typ), and  $R_{\text{IINP}}$  is the resistor connected between IINP and ground. Typically, IINP has a 0V to 3.5V output voltage range. Leave IINP unconnected when not used.

# 1.2MHz Low-Cost, High-Performance Chargers

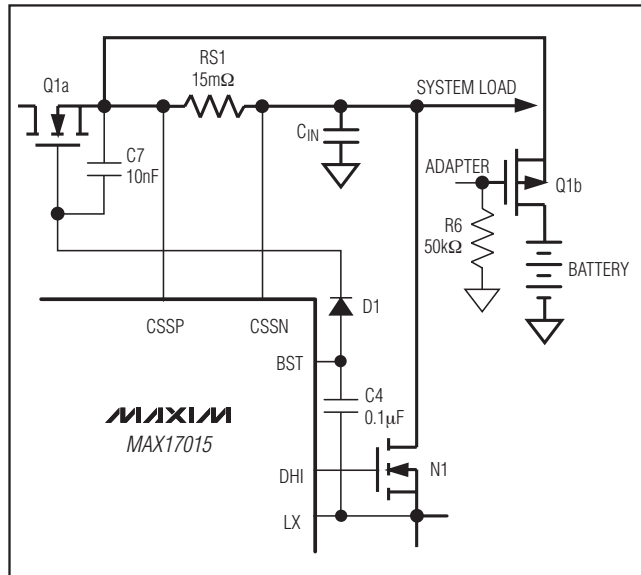

Figure 5. Current-Monitoring Design Battery Discharge

IINP can also be used to monitor battery discharge current (see Figure 5). In the MAX17015, when the adapter is absent, drive ISET above 1V to enable IINP during battery discharge. When the adapter is reinserted, ISET must be released to the correct control level within 300ms.

### AC Adapter Detection

The MAX17005/MAX17006/MAX17015 include a hysteretic comparator that detects the presence of an AC power adapter. When ACIN is lower than 2.1V, the open-drain  $\overline{\text{ACOK}}$  output becomes high impedance. Connect a 10k $\Omega$  pullup resistance between LDO and  $\overline{\text{ACOK}}$ . Use a resistive voltage-divider from the adapter's output to the ACIN pin to set the appropriate detection threshold. Select the resistive voltage-divider so that the voltage on ACIN does not to exceed its absolute maximum rating (6V).

### LDO Regulator and V<sub>AA</sub>

An integrated low-dropout (LDO) linear regulator provides a 5.4V supply derived from DCIN, and delivers over 40mA of load current. Do not use the LDO to external loads greater than 10mA. The LDO powers the gate drivers of the n-channel MOSFETs. See the *MOSFET Drivers* section. Bypass LDO to PGND with a 4.7 $\mu\text{F}$  ceramic capacitor. V<sub>AA</sub> is 4.2V reference supplied by DCIN. V<sub>AA</sub> biases most of the control circuitry, and should be bypassed to GND with a 1 $\mu\text{F}$  or greater ceramic capacitor.

### Operating Conditions

The MAX17005/MAX17006/MAX17015 have the following operating states:

- **Adapter Present:** When DCIN is greater than 8.7V, the controller detects the adapter. In this condition, both the LDO and V<sub>AA</sub> turn on and battery charging is allowed:
  - a) **Charging:** The total MAX17005/MAX17006/MAX17015 quiescent current when charging is 3mA (max) plus the current required to drive the MOSFETs.
  - b) **Not Charging:** To disable charging drive ISET below 26mV. When the adapter is present and charging is disabled, the total adapter quiescent current is less than 1.5mA and the total battery quiescent current is less than 60 $\mu\text{A}$ . The charge pump still operates.
- **Adapter Absent (Power Fail):** When V<sub>DCIN</sub> is less than V<sub>CSIN</sub> + 120mV, the DC-DC converter is in dropout. The charger detects the dropout condition and shuts down.

The MAX17005/MAX17006/MAX17015 allow charging under the following conditions:

- DCIN > 7.5V, LDO > 4V, V<sub>AA</sub> > 3.1V
- V<sub>DCIN</sub> > V<sub>CSIN</sub> + 420mV (300mV falling hysteresis)
- V<sub>ISET</sub> > 45mV or PWM detected

### DC-DC Converter

The MAX17005/MAX17006/MAX17015 employ a synchronous step-down DC-DC converter with an n-channel high-side MOSFET switch and an n-channel low-side synchronous rectifier. The charger features a controlled inductor current-ripple architecture, current-mode control scheme with cycle-by-cycle current limit. The controller's off-time (t<sub>OFF</sub>) is adjusted to keep the high-side MOSFET junction temperature constant. In this way, the controller switches faster when the high-side MOSFET has available thermal capacity. This allows the inductor current ripple and the output-voltage ripple to decrease so that smaller and cheaper components can be used. The controller can also operate in discontinuous conduction mode for improved light-load efficiency.

# 1.2MHz Low-Cost, High-Performance Chargers

MAX17005/MAX17006/MAX17015

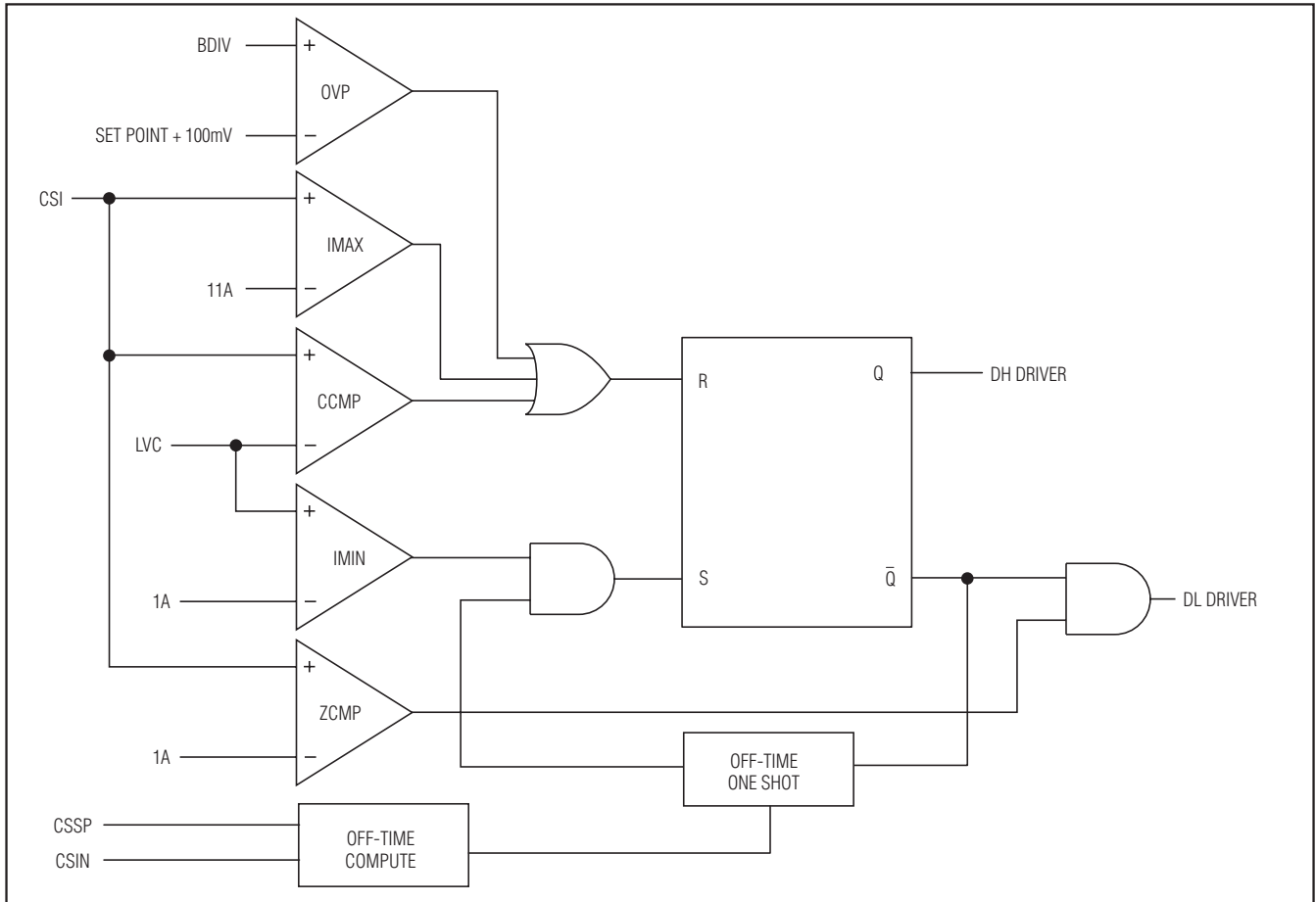

Figure 6. DC-DC Converter Functional Diagram

The operation of the DC-to-DC controller is determined by the following five comparators as shown in the functional diagram in Figures 2 and 6:

- The IMIN comparator triggers a pulse in discontinuous mode when the accumulated error is too high. IMIN compares the control signal (LVC) against 10mV (referred at  $V_{CSIP} - V_{CSIN}$ ). When LVC is less than this threshold, DHI and DLO are both forced low. Indirectly, IMIN sets the peak inductor current in discontinuous mode.
- The CCMP comparator is used for current-mode regulation in continuous-conduction mode. CCMP compares LVC against the inductor current. The high-side MOSFET on-time is terminated when the CSI voltage is higher than LVC.
- The IMAX comparator provides a secondary cycle-by-cycle current limit. IMAX compares CSI to 110mV (corresponding to 11A when  $RS2 = 10m\Omega$ ).
- The ZCMP comparator provides zero-crossing detection during discontinuous conduction. ZCMP compares the current-sense feedback signal to 1A ( $RS2 = 10m\Omega$ ). When the inductor current is lower than the 1A threshold, the comparator output is high, and DLO is turned off.
- The OVP comparator is used to prevent overvoltage at the output due to battery removal. OVP compares BATT against the VCTL. When BATT is 100mV/cell above the set value, the OVP comparator output goes high, and the high-side MOSFET on-time is terminated. DHI and DLO remain off until the OVP condition is removed.

# 1.2MHz Low-Cost, High-Performance Chargers

## CC, CCI, CCS, and LVC Control Blocks

The MAX17005/MAX17006/MAX17015 control input current (CCS control loop), charge current (CCI control loop), or charge voltage (CC control loop), depending on the operating condition. The three control loops, CC, CCI, and CCS are brought together internally at the lowest voltage clamp (LVC) amplifier. The output of the LVC amplifier is the feedback control signal for the DC-DC controller. The minimum voltage at the CC, CCI, or CCS appears at the output of the LVC amplifier and clamps the other control loops to within 0.3V above the control point. Clamping the other two control loops close to the lowest control loop ensures fast transition with minimal overshoot when switching between different control loops (see the *Compensation* section). The CCS and CCI loops are compensated internally, and the CC loop is compensated externally.

## Continuous-Conduction Mode

With sufficiently large charge current, the MAX17005/MAX17006/MAX17015s' inductor current never crosses zero, which is defined as continuous-conduction mode. The controller starts a new cycle by turning on the high-side MOSFET and turning off the low-side MOSFET. When the charge-current feedback signal (CSI) is greater than the control point (LVC), the CCMP comparator output goes high and the controller initiates the off-time by turning off the high-side MOSFET and turning on the low-side MOSFET. The operating frequency is governed by the off-time and is dependent upon  $V_{CSIN}$  and  $V_{DCIN}$ .

The on-time can be determined using the following equation:

$$t_{ON} = \frac{L \times I_{RIPPLE}}{V_{DCIN} - V_{BATT}}$$

where:

$$I_{RIPPLE} = \frac{V_{BATT} \times t_{OFF}}{L}$$

The switching frequency can then be calculated:

$$f_{SW} = \frac{1}{t_{ON} + t_{OFF}}$$

At the end of the computed off-time, the controller initiates a new cycle if the control point (LVC) is greater than 10mV ( $V_{CSIP} - V_{CSIN}$  referred), and the charge current is less than the cycle-by-cycle current limit. Restated another way,  $I_{MIN}$  must be high,  $I_{MAX}$  must be low, and OVP must be low for the controller to initiate a new cycle. If the peak inductor current exceeds  $I_{MAX}$  comparator threshold or the output voltage exceeds the OVP threshold, then the on-time is terminated. The cycle-by-cycle current limit effectively protects against overcurrent and short-circuit faults.

If during the off-time the inductor current goes to zero, the ZCOMP comparator output pulls high, turning off the low-side MOSFET. Both the high- and low-side MOSFETs are turned off until another cycle is ready to begin. ZCOMP causes the MAX17005/MAX17006/MAX17015 to enter into the discontinuous conduction mode (see the *Discontinuous Conduction* section).

## Discontinuous Conduction

The MAX17005/MAX17006/MAX17015 can also operate in discontinuous conduction mode to ensure that the inductor current is always positive. The MAX17005/MAX17006/MAX17015 enter discontinuous conduction mode when the output of the LVC control point falls below 10mV (referred at  $V_{CSIP} - V_{CSIN}$ ). For  $R_{S2} = 10m\Omega$ , this corresponds to a peak inductor current of 1A.

In discontinuous mode, a new cycle is not started until the LVC voltage rises above  $I_{MIN}$ . Discontinuous mode operation can occur during conditioning charge of overdischarged battery packs, when the charge current has been reduced sufficiently by the CCS control loop, or when the charger is in constant-voltage mode with a nearly full battery pack.

## Compensation

The charge voltage, charge current, and input current-limit regulation loops are compensated separately. The charge current and input current-limit loops, CCI and CCS, are compensated internally, whereas the charge voltage loop is compensated externally at CC.

# 1.2MHz Low-Cost, High-Performance Chargers

## CC Loop Compensation

The simplified schematic in Figure 7 is sufficient to describe the operation of the controller's voltage loop, CC. The required compensation network is a pole-zero pair formed with  $C_{CC}$  and  $R_{CC}$ . The zero is necessary to compensate the pole formed by the output capacitor and the load.  $R_{ESR}$  is the equivalent series resistance (ESR) of the charger output capacitor ( $C_{OUT}$ ).  $R_L$  is the equivalent charger output load, where  $R_L = \Delta V_{BATT} / \Delta I_{CHG}$ . The equivalent output impedance of the GMV amplifier,  $R_{OGMV}$ , is greater than  $10M\Omega$ . The voltage-amplifier transconductance,  $GMV = 0.125\mu A/mV$ . The DC-DC converter transconductance is dependent upon charge current-sense resistor  $RS2$ :

$$GM_{OUT} = \frac{1}{ACSI \times RS2}$$

where  $ACSI = 20$ , and  $RS2 = 10m\Omega$  in the typical application circuits, so  $GM_{OUT} = 5A/V$ .

The loop transfer function is given by:

$$LTF = GM_{OUT} \times R_L \times GMV \times R_{OGMV} \times \frac{(1 + sC_{OUT} \times R_{ESR})(1 + sC_{CC} \times R_{CC})}{(1 + sC_{CC} \times R_{OGMV})(1 + sC_{OUT} \times R_L)}$$

The poles and zeros of the voltage-loop transfer function are listed from lowest frequency to highest frequency in Table 2.

Near crossover,  $C_{CC}$  is much lower impedance than  $R_{OGMV}$ . Since  $C_{CC}$  is in parallel with  $R_{OGMV}$ ,  $C_{CC}$  dominates the parallel impedance near crossover. Additionally,  $R_{CC}$  is much higher impedance than  $C_{CC}$  and dominates the series combination of  $R_{CC}$  and  $C_{CC}$ , so:

$$\frac{R_{OGMV} \times (1 + sC_{CC} \times R_{CC})}{(1 + sC_{CC} \times R_{OGMV})} \approx R_{CC}$$

$C_{OUT}$  is also much lower impedance than  $R_L$  near crossover so the parallel impedance is mostly capacitive and:

$$\frac{R_L}{(1 + sC_{OUT} \times R_L)} \approx \frac{1}{sC_{OUT}}$$

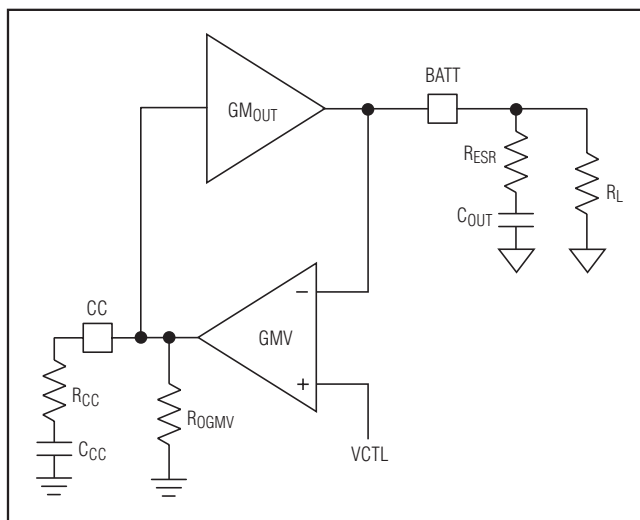

Figure 7. CC Loop Diagram

Table 2. CC Loop Poles and Zeros

NAME	EQUATION	DESCRIPTION
CCV Pole	$f_{P\_CV} = \frac{1}{2\pi R_{OGMV} \times C_{CC}}$	Lowest frequency pole created by $C_{CV}$ and GMV's finite output resistance.
CCV Zero	$f_{Z\_CV} = \frac{1}{2\pi R_{CC} \times C_{CC}}$	Voltage-loop compensation zero. If this zero is at the same frequency or lower than output pole $f_{P\_OUT}$ , the loop-transfer function approximates a single-pole response near the crossover frequency. Choose $C_{CV}$ to place this zero at least one decade below crossover to ensure adequate phase margin.
Output Pole	$f_{P\_OUT} = \frac{1}{2\pi R_L \times C_{OUT}}$	Output pole formed with the effective load resistance $R_L$ and the output capacitance $C_{OUT}$ . $R_L$ influences the DC gain but does not affect the stability of the system or the crossover frequency.
Output Zero	$f_{Z\_OUT} = \frac{1}{2\pi R_{ESR} \times C_{OUT}}$	Output ESR Zero. This zero can keep the loop from crossing unity gain if $f_{Z\_OUT}$ is less than the desired crossover frequency; therefore, choose a capacitor with an ESR zero greater than the crossover frequency.

# 1.2MHz Low-Cost, High-Performance Chargers

If  $R_{ESR}$  is small enough, its associated output zero has a negligible effect near crossover and the loop-transfer-function can be simplified as follows:

$$LTF = G_{MOUT} \times \frac{R_{CC}}{sC_{OUT}} G_{MV}$$

Setting  $LTF = 1$  to solve for the unity-gain frequency yields:

$$f_{CO\_CV} = G_{MOUT} \times G_{MV} \times \frac{R_{CC}}{2\pi \times C_{OUT}}$$

For stability, choose a crossover frequency lower than 1/10 the switching frequency ( $f_{OSC}$ ). For example, choose a crossover frequency of 50kHz and solve for  $R_{CC}$  using the component values listed in Figure 1 to yield  $R_{CC} = 3k\Omega$ :

$$R_{CC} = \frac{2\pi \times C_{OUT} \times f_{CO\_CV}}{G_{MV} \times G_{MOUT}} \approx 3k\Omega$$

$G_{MV} = 0.125\mu A/mV$

$G_{MOUT} = 5A/V$

$C_{OUT} = 4.7\mu F$

$f_{OSC\_CV} = 600kHz$

$R_L = 0.2\Omega$

$f_{CO\_CV} = 50kHz$

To ensure that the compensation zero adequately cancels the output pole, select  $f_{Z\_CV} \leq f_{P\_OUT}$ :

$$C_{CC} \geq (R_L/R_{CC}) \times C_{OUT}$$

$C_{CC} \geq 300pF$  (assuming 2 cells and 2A maximum charge current).

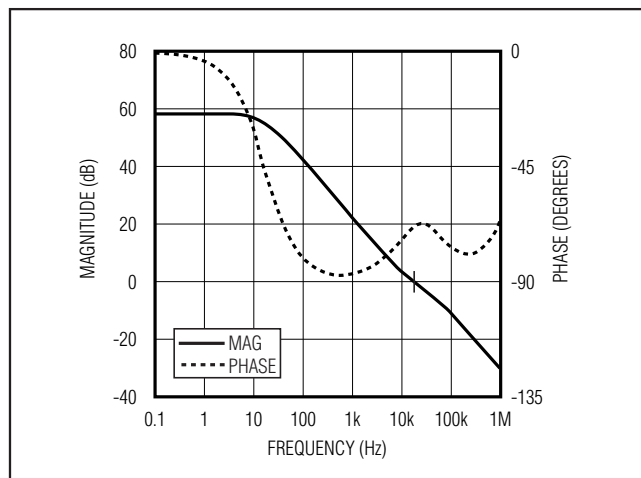

Figure 8. CC Loop Response

Figure 8 shows the Bode plot of the voltage-loop-frequency response using the values calculated above.

## MOSFET Drivers

The DHI and DLO outputs are optimized for driving moderate-sized power MOSFETs. The MOSFET drive capability is the same for both the low-side and high-sides switches. This is consistent with the variable duty factor that occurs in the notebook computer environment where the battery voltage changes over a wide range. There must be a low-resistance, low-inductance path from the DLO driver to the MOSFET gate to prevent shoot-through. Otherwise, the sense circuitry in the MAX17005/MAX17006 interpret the MOSFET gate as “off” while there is still charge left on the gate. Use very short, wide traces measuring 10 to 20 squares or fewer (1.25mm to 2.5mm wide if the MOSFET is 25mm from the device). Unlike the DLO output, the DHI output uses a 50ns (typ) delay time to prevent the low-side MOSFET from turning on until DHI is fully off. The same considerations should be used for routing the DHI signal to the high-side MOSFET.

The high-side driver (DHI) swings from LX to 5V above LX (BST) and has a typical impedance of 1.5Ω sourcing and 0.8Ω sinking. The strong high-side MOSFET driver eliminates most of the power dissipation due to switching losses. The low-side driver (DLO) swings from LDO to ground and has a typical impedance of 3Ω sinking and 3Ω sourcing. This helps prevent DLO from being pulled up when the high-side switch turns on due to capacitive coupling from the drain to the gate of the low-side MOSFET. This places some restrictions on the MOSFETs that can be used. Using a low-side MOSFET with smaller gate-to-drain capacitance can prevent these problems.

## Design Procedure

### MOSFET Selection

Choose the n-channel MOSFETs according to the maximum required charge current. The MOSFETs must be able to dissipate the resistive losses plus the switching losses at both  $V_{DCIN(MIN)}$  and  $V_{DCIN(MAX)}$ .

For the high-side MOSFET, the worst-case resistive power losses occur at the maximum battery voltage and minimum supply voltage:

$$PD_{COND}(\text{High Side}) = \frac{V_{BATT(MAX)}}{V_{DCIN(MIN)}} \times I_{CHG}^2 \times R_{DS(ON)}$$

# 1.2MHz Low-Cost, High-Performance Chargers

Generally, a low gate charge high-side MOSFET is preferred to minimize switching losses. However, the  $R_{DS(ON)}$  required to stay within package power dissipation often limits how small the MOSFET can be. The optimum occurs when the switching losses equal the conduction losses. High-side switching losses do not usually become an issue until the input is greater than approximately 15V. Calculating the power dissipation in N1 due to switching losses is difficult since it must allow for difficult quantifying factors that influence the turn-on and turn-off times. These factors include the internal gate resistance, gate charge, threshold voltage, source inductance, and PCB layout characteristics. The following switching-loss calculation provides only a very rough estimate and is no substitute for breadboard evaluation, preferably including a verification using a thermocouple mounted on N1:

$$PD_{SW}(HS) = \frac{1}{2} \times t_{TRANS} \times V_{CSP} \times I_{CHG} \times f_{SW}$$

where  $t_{TRANS}$  is the drivers transition time and can be calculated as follows:

$$t_{TRANS} = \left( \frac{1}{I_{GSR}} + \frac{1}{I_{GSNK}} \right) \times (Q_{GD} + Q_{GS})$$

$I_{GSR}$  and  $I_{GSNK}$  are the peak gate-drive source/sink current (3Ω sourcing and 0.8Ω sinking, typically). The MAX17005/MAX17006/MAX17015 control the switching frequency as shown in the *Typical Operating Characteristics*.

The following is the power dissipated due to high-side n-channel MOSFET's output capacitance ( $C_{RSS}$ ):

$$PD_{CRSS}(HS) \approx \frac{V_{CSP}^2 \times C_{RSS} \times f_{SW}}{2}$$

The following high-side MOSFET's loss is due to the reverse-recovery charge of the low-side MOSFET's body diode:

$$PD_{QRR}(HS) = \frac{Q_{RR2} \times V_{CSP} \times f_{SW}}{2}$$

Ignore  $PD_{QRR}(HighSide)$  if a Schottky diode is used parallel to a low-side MOSFET.

The total high-side MOSFET power dissipation is:

$$PD_{TOTAL}(HS) \approx PD_{COND}(HS) + PD_{SW}(HS) + PD_{CRSS}(HS) + PD_{QRR}(HS)$$

Switching losses in the high-side MOSFET can become an insidious heat problem when maximum AC adapter voltages are applied. If the high-side MOSFET chosen for adequate  $R_{DS(ON)}$  at low-battery voltages becomes hot when biased from  $V_{DCIN(MAX)}$ , consider choosing another MOSFET with lower parasitic capacitance.

For the low-side MOSFET (N2), the worst-case power dissipation always occurs at maximum input voltage:

$$PD_{COND}(LS) = \left( 1 - \frac{V_{BATT(MIN)}}{V_{CSP(MAX)}} \right) \times I_{CHG}^2 \times R_{DS(ON)}$$

The following additional loss occurs in the low-side MOSFET due to the body diode conduction losses:

$$PD_{BDY}(LS) = 0.05 \times I_{PEAK} \times 0.4V$$

The total power low-side MOSFET dissipation is:

$$PD_{TOTAL}(LS) \approx PD_{COND}(LS) + PD_{BDY}(LS)$$

These calculations provide an estimate and are not a substitute for breadboard evaluation, preferably including a verification using a thermocouple mounted on the MOSFET.

## Inductor Selection

The selection of the inductor has multiple trade-offs between efficiency, transient response, size, and cost. Small inductance is cheap and small, and has a better transient response due to higher slew rate; however, the efficiency is lower because of higher RMS current. High inductance results in lower ripple so that the need of the output capacitors for output voltage ripple goes low.

The MAX17005/MAX17006/MAX17015 combine all the inductor trade-offs in an optimum way by controlling switching frequency. High-frequency operation permits the use of a smaller and cheaper inductor, and consequently results in smaller output ripple and better transient response.

The charge current, ripple, and operating frequency (off-time) determine the inductor characteristics. For optimum efficiency, choose the inductance according to the following equation:

$$L = \frac{k \times V_{IN}^2}{4 \times I_{CHG} \times LIR_{MAX}}$$

where  $k = 35ns/V$ .

# 1.2MHz Low-Cost, High-Performance Chargers

For optimum size and inductor current ripple, choose  $LIR_{MAX} = 0.4$ , which sets the ripple current to 40% the charge current and results in a good balance between inductor size and efficiency. Higher inductor values decrease the ripple current. Smaller inductor values save cost but require higher saturation current capabilities and degrade efficiency.

Inductor L1 must have a saturation current rating of at least the maximum charge current plus 1/2 the ripple current ( $\Delta I_L$ ):

$$I_{SAT} = I_{CHG} + (1/2) \Delta I_L$$

The ripple current is determined by:

$$\Delta I_L = \frac{k \times V_{IN}^2}{4L}$$

## Input Capacitor Selection

The input capacitor must meet the ripple current requirement ( $I_{RMS}$ ) imposed by the switching currents. Nontantalum chemistries (ceramic, aluminum, or OS-CON) are preferred due to their resilience to power-up and surge currents:

$$I_{RMS} = I_{CHG} \times \left( \frac{\sqrt{V_{BATT} \times (V_{DCIN} - V_{BATT})}}{V_{DCIN}} \right)$$

The input capacitors should be sized so that the temperature rise due to ripple current in continuous conduction does not exceed approximately 10°C. The maximum ripple current occurs at 50% duty factor or  $V_{DCIN} = 2 \times V_{BATT}$ , which equates to  $0.5 \times I_{CHG}$ . If the application of interest does not achieve the maximum value, size the input capacitors according to the worst-case conditions.

## Output Capacitor Selection

The output capacitor absorbs the inductor ripple current and must tolerate the surge current delivered from the battery when it is initially plugged into the charger. As such, both capacitance and ESR are important parameters in specifying the output capacitor as a filter and to ensure the stability of the DC-to-DC converter (see the *Compensation* section.) Beyond the stability requirements, it is often sufficient to make sure that the output capacitor's ESR is much lower than the battery's ESR. Either tantalum or ceramic capacitors can be used on the output. Ceramic devices are preferable because of their good voltage ratings and resilience to surge currents. Choose the output capacitor based on:

$$C_{OUT} = \frac{I_{RIPPLE}}{f_{SW} \times 8 \times \Delta V_{BATT}} \times k_{CAP-BIAS}$$

Choose  $k_{CAP-BIAS}$  is a derating factor of 2 for typical 25V-rated ceramic capacitors.

For  $f_{SW} = 800\text{kHz}$ ,  $I_{RIPPLE} = 1\text{A}$ , and to get  $\Delta V_{BATT} = 70\text{mV}$ , choose  $C_{OUT}$  as  $4.7\mu\text{F}$ .

If the internal resistance of battery is close to the ESR of the output capacitor, the voltage ripple is shared with the battery and is less than calculated.

## Applications Information

### Setting Input Current Limit

The input current limit should be set based on the current capability of the AC adapter and the tolerance of the input current limit. The upper limit of the input current threshold should never exceed the adapter's minimum available output current. For example, if the adapter's output current rating is  $5\text{A} \pm 10\%$ , the input current limit should be selected so that its upper limit is less than  $5\text{A} \times 0.9 = 4.5\text{A}$ . Since the input current-limit accuracy of the MAX17005/MAX17006/MAX17015 is  $\pm 3\%$ , the typical value of the input current limit should be set at  $4.5\text{A}/1.03 \approx 4.36\text{A}$ . The lower limit for input current must also be considered. For chargers at the low end of the spec, the input current limit for this example could be  $4.36\text{A} \times 0.95$  or approximately  $4.14\text{A}$ .

### Layout and Bypassing

Bypass  $DCIN$  with a  $0.1\mu\text{F}$  ceramic to ground (Figure 1). N1 and N2 protect the MAX17005/MAX17006/MAX17015 when the DC power source input is reversed. Bypass  $V_{AA}$ ,  $CSSP$ , and  $LDO$  as shown in Figure 1.

Good PCB layout is required to achieve specified noise immunity, efficiency, and stable performance. The PCB layout designer must be given explicit instructions—preferably, a sketch showing the placement of the power switching components and high current routing. Refer to the PCB layout in the MAX17005/MAX17006/MAX17015 evaluation kit for examples. A ground plane is essential for optimum performance. In most applications, the circuit is located on a multilayer board, and full use of the four or more copper layers is recommended. Use the top layer for high-current connections, the bottom layer for quiet connections, and the inner layers for an uninterrupted ground plane.

Use the following step-by-step guide:

- 1) Place the high-power connections first, with their grounds adjacent:
  - a) Minimize the current-sense resistor trace lengths, and ensure accurate current sensing with Kelvin connections.
  - b) Minimize ground trace lengths in the high-current paths.

# 1.2MHz Low-Cost, High-Performance Chargers

- c) Minimize other trace lengths in the high-current paths.
- d) Use > 5mm wide traces in the high-current paths.
- e) Connect  $C_{IN}$  to high-side MOSFET (10mm max length).
- f) Minimize the LX node (MOSFETs, rectifier cathode, inductor (15mm max length)). Keep LX on one side of the PCB to reduce EMI radiation.

Ideally, surface-mount power components are flush against one another with their ground terminals almost touching. These high-current grounds are then connected to each other with a wide, filled zone of top-layer copper, so they do not go through vias. The resulting top-layer subground plane is connected to the normal inner-layer ground plane at the paddle. Other high-current paths should also be minimized, but focusing primarily on short ground and current-sense connections eliminates about 90% of all PCB layout problems.

- 2) Place the IC and signal components. Keep the main switching node (LX node) away from sensitive analog components (current-sense traces and  $V_{AA}$

capacitor). **Important:** the IC must be no further than 10mm from the current-sense resistors. Quiet connections to  $V_{AA}$  and CC should be returned to a separate ground (GND) island. There is very little current flowing in these traces, so the ground island need not be very large. When placed on an inner layer, a sizable ground island can help simplify the layout because the low-current connections can be made through vias. The ground pad on the backside of the package should also be connected to this quiet ground island.

- 3) Keep the gate drive traces (DHI and DLO) as short as possible ( $L < 20\text{mm}$ ), and route them away from the current-sense lines and  $V_{AA}$ . These traces should also be relatively wide ( $W > 1.25\text{mm}$ ).
- 4) Place ceramic bypass capacitors close to the IC. The bulk capacitors can be placed further away. Place the current-sense input filter capacitors under the part, connected directly to the GND pin.
- 5) Use a single-point star ground placed directly below the part at the PGND pin. Connect the power ground (ground plane) and the quiet ground island at this location.

# 1.2MHz Low-Cost, High-Performance Chargers

## Minimal Operating Circuit

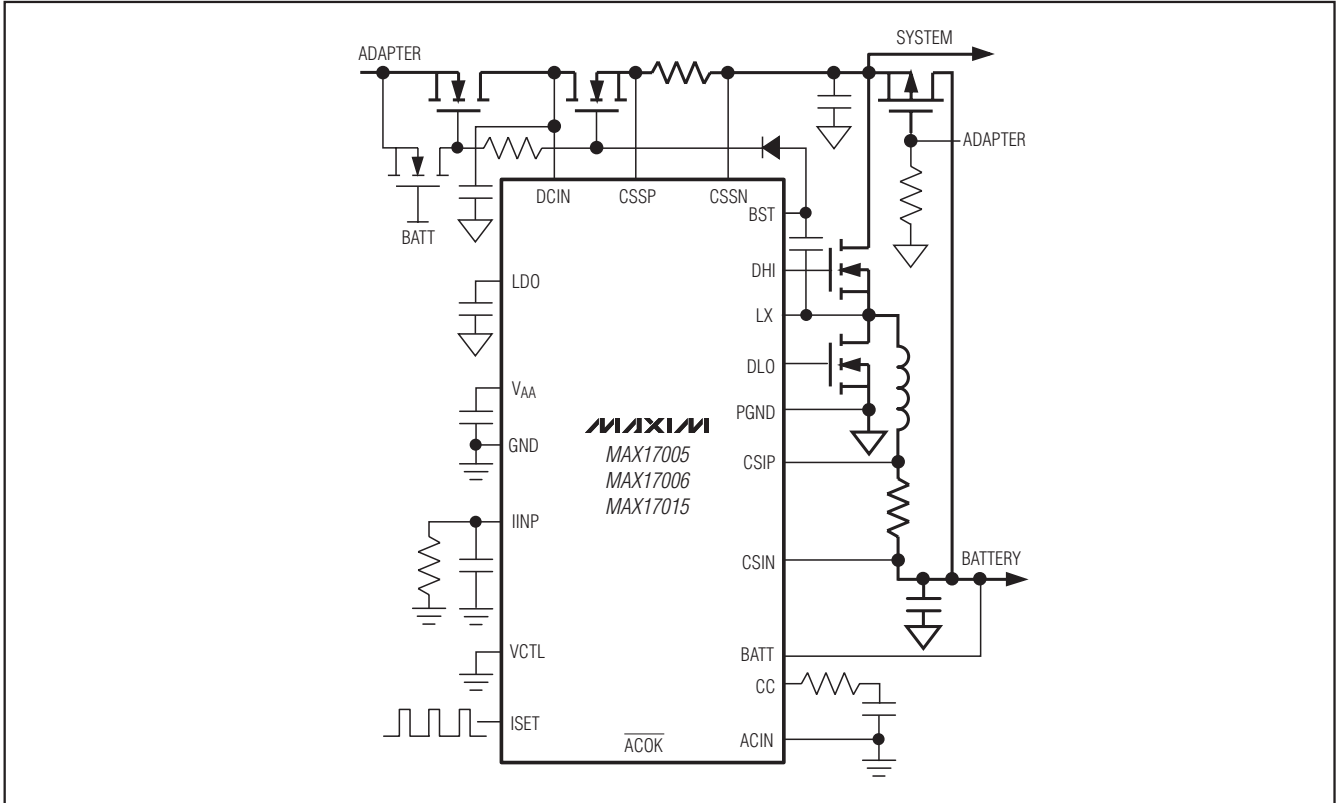

## Pin Configuration

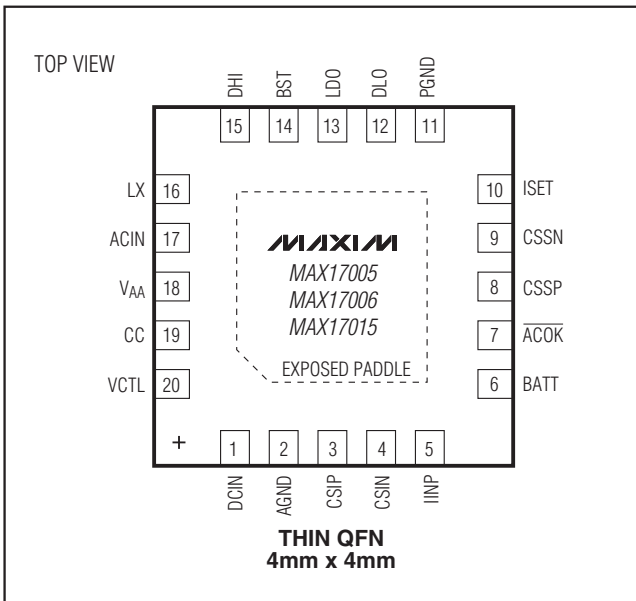

## Chip Information

TRANSISTOR COUNT: 12,990  
PROCESS: BiCMOS

# 1.2MHz Low-Cost, High-Performance Chargers

## Package Information

(The package drawing(s) in this data sheet may not reflect the most current specifications. For the latest package outline information go to [www.maxim-ic.com/packages](http://www.maxim-ic.com/packages).)

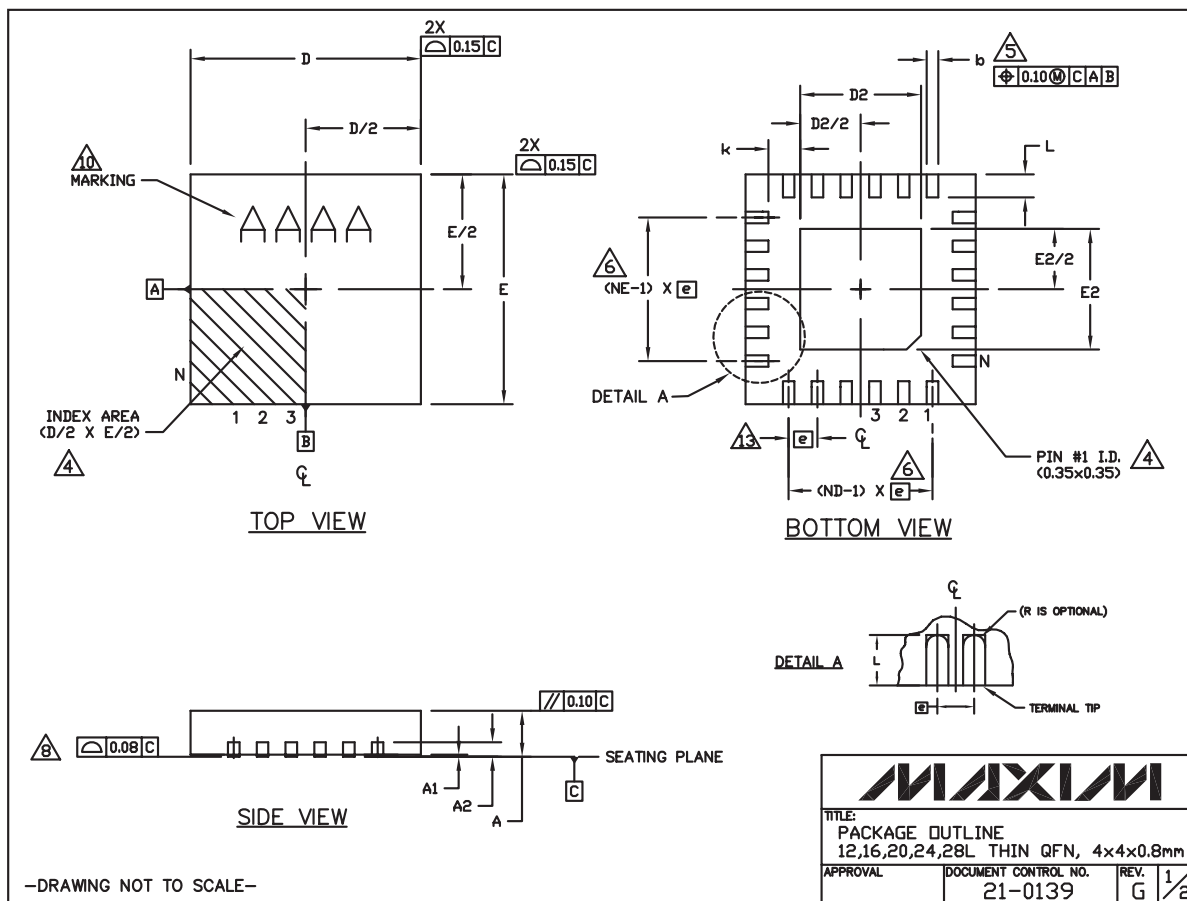

24L QFN THIN EPS

MAX17005/MAX17006/MAX17015

-DRAWING NOT TO SCALE-

# 1.2MHz Low-Cost, High-Performance Chargers

## Package Information (continued)

(The package drawing(s) in this data sheet may not reflect the most current specifications. For the latest package outline information go to [www.maxim-ic.com/packages](http://www.maxim-ic.com/packages).)

COMMON DIMENSIONS															
PKG	12L 4x4			16L 4x4			20L 4x4			24L 4x4			28L 4x4		
REF.	MIN.	NDM.	MAX.	MIN.	NDM.	MAX.	MIN.	NDM.	MAX.	MIN.	NDM.	MAX.	MIN.	NDM.	MAX.
A	0.70	0.75	0.80	0.70	0.75	0.80	0.70	0.75	0.80	0.70	0.75	0.80	0.70	0.75	0.80
A1	0.0	0.02	0.05	0.0	0.02	0.05	0.0	0.02	0.05	0.0	0.02	0.05	0.0	0.02	0.05
A2	0.20 REF			0.20 REF			0.20 REF			0.20 REF			0.20 REF		
b	0.25	0.30	0.35	0.25	0.30	0.35	0.20	0.25	0.30	0.18	0.23	0.30	0.15	0.20	0.25
D	3.90	4.00	4.10	3.90	4.00	4.10	3.90	4.00	4.10	3.90	4.00	4.10	3.90	4.00	4.10
E	3.90	4.00	4.10	3.90	4.00	4.10	3.90	4.00	4.10	3.90	4.00	4.10	3.90	4.00	4.10
e	0.80 BSC.			0.65 BSC.			0.50 BSC.			0.50 BSC.			0.40 BSC.		
k	0.25	-	-	0.25	-	-	0.25	-	-	0.25	-	-	0.25	-	-
L	0.45	0.55	0.65	0.45	0.55	0.65	0.45	0.55	0.65	0.30	0.40	0.50	0.30	0.40	0.50
N	12			16			20			24			28		
ND	3			4			5			6			7		
NE	3			4			5			6			7		
Jedec Var.	WGBB			WGGC			WGGD-1			WGGD-2			WGGE		

EXPOSED PAD VARIATIONS							
PKG. CODES	D2			E2			
	MIN.	NDM.	MAX.	MIN.	NDM.	MAX.	
T1244-3	1.95	2.10	2.25	1.95	2.10	2.25	
T1244-4	1.95	2.10	2.25	1.95	2.10	2.25	
T1644-3	1.95	2.10	2.25	1.95	2.10	2.25	
T1644-4	1.95	2.10	2.25	1.95	2.10	2.25	
T2044-2	1.95	2.10	2.25	1.95	2.10	2.25	
T2044-3	1.95	2.10	2.25	1.95	2.10	2.25	
T2444-2	1.95	2.10	2.25	1.95	2.10	2.25	
T2444-3	2.45	2.60	2.63	2.45	2.60	2.63	
T2444-4	2.45	2.60	2.63	2.45	2.60	2.63	
T2844-1	2.50	2.60	2.70	2.50	2.60	2.70	

NOTES:

- DIMENSIONING & TOLERANCING CONFORM TO ASME Y14.5M-1994.
- ALL DIMENSIONS ARE IN MILLIMETERS. ANGLES ARE IN DEGREES.
- N IS THE TOTAL NUMBER OF TERMINALS.
- THE TERMINAL #1 IDENTIFIER AND TERMINAL NUMBERING CONVENTION SHALL CONFORM TO JESD 95-1 SPP-012. DETAILS OF TERMINAL #1 IDENTIFIER ARE OPTIONAL, BUT MUST BE LOCATED WITHIN THE ZONE INDICATED. THE TERMINAL #1 IDENTIFIER MAY BE EITHER A MOLD OR MARKED FEATURE.
- DIMENSION b APPLIES TO METALLIZED TERMINAL AND IS MEASURED BETWEEN 0.25mm AND 0.30mm FROM TERMINAL TIP.
- ND AND NE REFER TO THE NUMBER OF TERMINALS ON EACH D AND E SIDE RESPECTIVELY.
- DEPOPULATION IS POSSIBLE IN A SYMMETRICAL FASHION.
- COPLANARITY APPLIES TO THE EXPOSED HEAT SINK SLUG AS WELL AS THE TERMINALS.
- DRAWING CONFORMS TO JEDEC MO220, EXCEPT FOR T2444-3, T2444-4 AND T2844-1.
- MARKING IS FOR PACKAGE ORIENTATION REFERENCE ONLY.
- COPLANARITY SHALL NOT EXCEED 0.08mm.
- WARPAGE SHALL NOT EXCEED 0.10mm.
- LEAD CENTERLINES TO BE AT TRUE POSITION AS DEFINED BY BASIC DIMENSION 'e', ±0.05.
- NUMBER OF LEADS SHOWN ARE FOR REFERENCE ONLY.
- ALL DIMENSIONS ARE THE SAME FOR LEADED (-) & PbFREE (+) PACKAGE CODES.



TITLE:  
PACKAGE OUTLINE  
12,16,20,24,28L THIN QFN, 4x4x0.8mm

APPROVAL	DOCUMENT CONTROL NO. 21-0139	REV. G	2/2
----------	---------------------------------	-----------	-----

-DRAWING NOT TO SCALE-

Maxim cannot assume responsibility for use of any circuitry other than circuitry entirely embodied in a Maxim product. No circuit patent licenses are implied. Maxim reserves the right to change the circuitry and specifications without notice at any time.

24 **Maxim Integrated Products, 120 San Gabriel Drive, Sunnyvale, CA 94086 408-737-7600**

## Looking for pricing, stock, or lifecycle information?

Click below to explore more details on WIN SOURCE:

 [View MAX17006ETP+ on WIN SOURCE](#)

 [Maxim Integrated](#) Information

## Optimize Your Supply Chain with WIN SOURCE Solutions

-  Global Sourcing Solution
-  Obsolete Management
-  Cost Control Management
-  Shortage Management
-  Alternative Solution
-  Excess Inventory Management