



**THE DATASHEET OF  
MAX1647EAP**





# Chemistry-Independent Battery Chargers

MAX1647/MAX1648

## General Description

## Features

The MAX1647/MAX1648 provide the power control necessary to charge batteries of any chemistry. In the MAX1647, all charging functions are controlled through the Intel System Management Bus (SMBus™) interface. The SMBus 2-wire serial interface sets the charge voltage and current, and provides thermal status information. The MAX1647 functions as a level 2 charger, compliant with the Duracell/Intel Smart Battery Charger Specification. The MAX1648 omits the SMBus serial interface, and instead sets the charge voltage and current proportional to the voltage applied to external control pins.

- ◆ Charges Any Battery Chemistry: Li-Ion, NiCd, NiMH, Lead Acid, etc.
- ◆ Intel SMBus 2-Wire Serial Interface (MAX1647)
- ◆ Intel/Duracell Level 2 Smart Battery Compliant (MAX1647)
- ◆ 4A, 2A, or 1A Maximum Battery-Charge Current
- ◆ 11-Bit Control of Charge Current
- ◆ Up to 18V Battery Voltage
- ◆ 10-Bit Control of Voltage
- ◆ ±0.75% Voltage Accuracy with External ±0.1% Reference
- ◆ Up to 28V Input Voltage
- ◆ Battery Thermistor Fail-Safe Protection

In addition to the feature set required for a level 2 charger, the MAX1647 generates interrupts to signal the host when power is applied to the charger or a battery is installed or removed. Additional status bits allow the host to check whether the charger has enough input voltage, and whether the voltage on or current into the battery is being regulated. This allows the host to determine when lithium-ion batteries have completed charge without interrogating the battery.

The MAX1647 is available in a 20-pin SSOP with a 2mm profile height. The MAX1648 is available in a 16-pin SO package.

## Ordering Information

## Applications

- Notebook Computers
- Personal Digital Assistants
- Charger Base Stations
- Phones

PART	TEMP RANGE	PIN-PACKAGE
MAX1647EAP	-40°C to +85°C	20 SSOP
MAX1648ESE	-40°C to +85°C	16 Narrow SO

## Pin Configurations

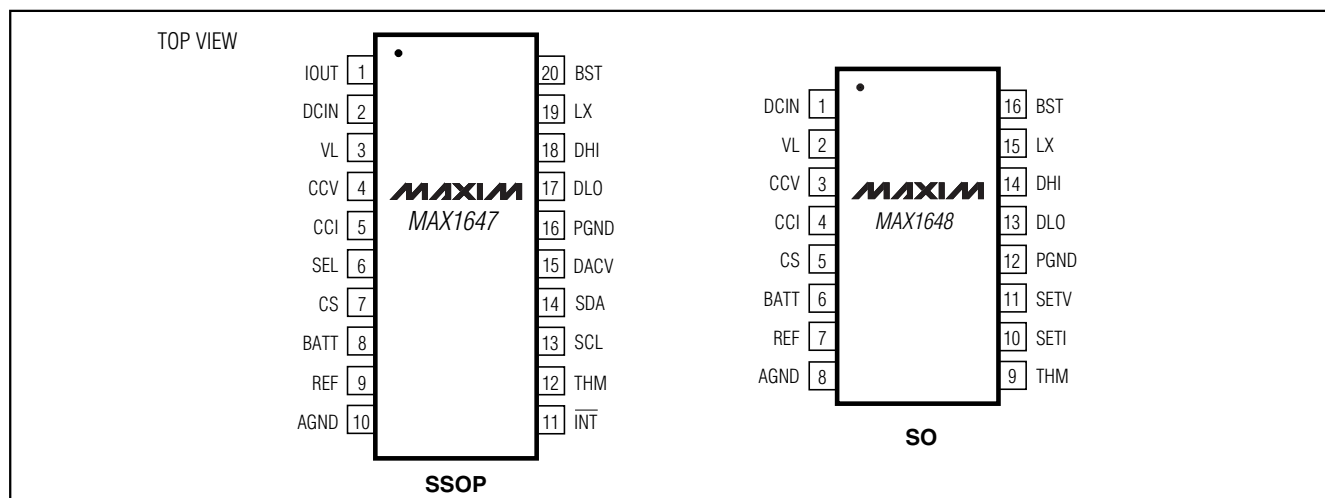

SMBus is a trademark of Intel Corp.



**For pricing, delivery, and ordering information, please contact Maxim/Dallas Direct! at 1-888-629-4642, or visit Maxim's website at [www.maxim-ic.com](http://www.maxim-ic.com).**

# Chemistry-Independent Battery Chargers

## ABSOLUTE MAXIMUM RATINGS

DCIN to AGND	-0.3V to 30V	PGND to AGND	-0.3V to +0.3V
DCIN to IOUT	-0.3V to 7.5V	SDA, INT Current	50mA
BST to AGND	-0.3V to 36V	VL Current	50mA
BST, DHI to LX	-0.3V to 6V	Continuous Power Dissipation (T <sub>A</sub> = +70°C)	
LX to AGND	-0.3V to 30V	16-Pin SO (derate 8.7mW/°C above +70°C)	696mW
THM, CCI, CCV, DACV, REF,		20-Pin SSOP (derate 8mW/°C above +70°C)	640mW
DLO to AGND	-0.3V to (VL + 0.3V)	Operating Temperature Range	
VL, SEL, INT, SDA, SCL to AGND (MAX1647)	-0.3V to 6V	MAX1647EAP, MAX1648ESE	-40°C to +85°C
SETV, SETI to AGND (MAX1648)	-0.3V to 6V	Storage Temperature	-60°C to +150°C
BATT, CS+ to AGND	-0.3V to 20V	Lead Temperature (soldering, 10s)	+300°C

Stresses beyond those listed under "Absolute Maximum Ratings" may cause permanent damage to the device. These are stress ratings only, and functional operation of the device at these or any other conditions beyond those indicated in the operational sections of the specifications is not implied. Exposure to absolute maximum rating conditions for extended periods may affect device reliability.

## ELECTRICAL CHARACTERISTICS

(V<sub>DCIN</sub> = 18V, V<sub>REF</sub> = 4.096V, T<sub>A</sub> = 0°C to +85°C. Typical values are at T<sub>A</sub> = +25°C, unless otherwise noted.)

PARAMETER	CONDITIONS	MIN	TYP	MAX	UNITS
<b>SUPPLY AND REFERENCE</b>					
DCIN Input Voltage Range		7.5		28.0	V
DCIN Quiescent Current	7.5V < V <sub>DCIN</sub> < 28V, logic inputs = VL		4	6	mA
VL Output Voltage	7.5V < V <sub>DCIN</sub> < 28V, no load	5.15	5.4	5.65	V
VL Load Regulation	I <sub>LOAD</sub> = 10mA			100	mV
VL AC_PRESENT Trip Point	MAX1647	3.20	4	5.15	V
REF Output Voltage	0μA < I <sub>SOURCE</sub> < 500μA	3.74	3.9	4.07	V
REF Overdrive Input Current				700	μA
<b>SWITCHING REGULATOR</b>					
Oscillator Frequency		200	250	300	kHz
DHI Maximum Duty Cycle		89	93		%
DHI On-Resistance	High or low		4	7	Ω
DLO On-Resistance	High or low		6	14	Ω
BATT Input Current (Note 1)	VL < 3.2V, V <sub>BATT</sub> = 12V		1	5	μA
	VL < 5.15V, V <sub>BATT</sub> = 12V		350	500	
CS Input Current (Note 1)	VL < 3.2V, V <sub>CS</sub> = 12V		1	5	μA
	VL < 5.15V, V <sub>CS</sub> = 12V		170	400	
BATT, CS Input Voltage Range		0		19	V
CS to BATT Single-Count Current-Sense Voltage	MAX1647, SEL = open, ChargingCurrent( ) = 0x0020		2.94		mV
CS to BATT Full-Scale Current-Sense Voltage	MAX1647, SEL = open, ChargingCurrent( ) = 0x07F0; MAX1648, V <sub>SETI</sub> = 1.024V	170	185	200	mV
Voltage Accuracy	MAX1647, ChargingVoltage( ) = 0x1060, ChargingVoltage( ) = 0x3130; MAX1648, V <sub>SETV</sub> = 3.15V, V <sub>SETV</sub> = 1.05V	-0.65		+0.65	%

# Chemistry-Independent Battery Chargers

MAX1647/MAX1648

## ELECTRICAL CHARACTERISTICS (continued)

(V<sub>DCIN</sub> = 18V, V<sub>REF</sub> = 4.096V, T<sub>A</sub> = 0°C to +85°C. Typical values are at T<sub>A</sub> = +25°C, unless otherwise noted.)

PARAMETER	CONDITIONS		MIN	TYP	MAX	UNITS
<b>ERROR AMPLIFIERS</b>						
GMV Amplifier Transconductance				1.4		mA/V
GMI Amplifier Transconductance				0.2		mA/V
GMV Amplifier Maximum Output Current				±80		μA
GMI Amplifier Maximum Output Current				±200		μA
CCI Clamp Voltage with Respect to CCV	1.1V < V <sub>CCV</sub> < 3.5V		25	80	200	mV
CCV Clamp Voltage with Respect to CCI	1.1V < V <sub>CCI</sub> < 3.5V		25	80	200	mV
<b>TRIP POINTS AND LINEAR CURRENT SOURCES</b>						
BATT POWER_FAIL Trip Point	MAX1647		86.5	89	91.5	% of V <sub>DCIN</sub>
THM THERMISTOR_OR Over-Range Trip Point	MAX1647		89.5	91	92.5	% of V <sub>REF</sub>
THM THERMISTOR_COLD Trip Point			74	75.5	77	% of V <sub>REF</sub>
THM THERMISTOR_HOT Trip Point			22	23.5	25	% of V <sub>REF</sub>
THM THERMISTOR_UR Under-Range Trip Point	MAX1647		3	4.5	6	% of V <sub>REF</sub>
IOUT Output Current	MAX1647, V <sub>DCIN</sub> = 7.5V, V <sub>IOUT</sub> = 0V	ChargingCurrent( ) = 0x001F	25	31	38	mA
		ChargingCurrent( ) = 0x0000			10	μA
IOUT Operating Voltage Range	With respect to DCIN voltage		-7.5		-1.0	V
<b>CURRENT- AND VOLTAGE-SETTING DACs (MAX1647)</b>						
CDAC Current-Setting DAC Resolution	Guaranteed monotonic		6			Bits
VDAC Voltage-Setting DAC Resolution	Guaranteed monotonic		10			Bits
<b>SETV, SETI (MAX1648)</b>						
SETV Input Bias Current					1	μA
SETI Input Bias Current					5	μA
SETV Input Voltage Range			0		4.2	V
SETI Input Voltage Range			0		1.024	V
<b>LOGIC LEVELS (MAX1647)</b>						
SDA, SCL Input Low Voltage					0.8	V
SDA, SCL Input High Voltage			2.8			V
SDA, SCL Input Bias Current			-1		+1	μA
SDA Output Low Sink Current	V <sub>SDA</sub> = 0.6V		6			mA

**Note 1:** When DCIN is less than 4V, VL is less than 3.2V, causing the battery current to be typically 2μA (CS plus BATT input current).

# Chemistry-Independent Battery Chargers

MAX1647/MAX1648

## ELECTRICAL CHARACTERISTICS

( $V_{DCIN} = 18V$ ,  $V_{REF} = 4.096V$ ,  $T_A = -40^{\circ}C$  to  $+85^{\circ}C$ . Typical values are at  $T_A = +25^{\circ}C$ , unless otherwise noted. Limits over this temperature range are guaranteed by design.)

PARAMETER	CONDITIONS	MIN	TYP	MAX	UNITS
<b>SUPPLY AND REFERENCE</b>					
DCIN Quiescent Current	$7.5V < V_{DCIN} < 28V$ , logic inputs = VL		4	6	mA
VL Output Voltage	$7.5V < V_{DCIN} < 28V$ , no load	5.15	5.4	5.65	V
REF Output Voltage	$0\mu A < I_{SOURCE} < 500\mu A$	3.74	3.9	4.07	V
<b>SWITCHING REGULATOR</b>					
Oscillator Frequency		200	250	310	kHz
DHI Maximum Duty Cycle		89			%
DHI On-Resistance	High or low		4	7	$\Omega$
DLO On-Resistance	High or low		6	14	$\Omega$
BATT Input Current	$VL < 3.2V$ , $V_{BATT} = 12V$			5	$\mu A$
CS Input Current	$VL < 3.2V$ , $V_{CS} = 12V$			5	$\mu A$
CS to BATT Full-Scale Current-Sense Voltage	MAX1647, SEL = open, ChargingCurrent( ) = 0x07F0; MAX1648, VSETI = 1.024V	160	185	200	mV
Voltage Accuracy	MAX1647, ChargingVoltage( ) = 0x1060, ChargingVoltage( ) = 0x3130; MAX1648, VSETV = 3.15V, VSETV = 1.05V	-0.65		+0.65	%
<b>ERROR AMPLIFIERS</b>					
GMV Amplifier Transconductance			1.4		mA/V
GMI Amplifier Transconductance			0.2		mA/V
GMV Amplifier Maximum Output Current			$\pm 130$		$\mu A$
GMI Amplifier Maximum Output Current			$\pm 320$		$\mu A$
<b>TRIP POINTS AND LINEAR CURRENT SOURCES</b>					
THM THERMISTOR_OR Over-Range Trip Point	MAX1647	89.5	91	92.5	% of $V_{REF}$
THM THERMISTOR_COLD Trip Point		74	75.5	77	% of $V_{REF}$
THM THERMISTOR_HOT Trip Point		22	23.5	25	% of $V_{REF}$
THM THERMISTOR_UR Under-Range Trip Point	MAX1647	3	4.5	6	% of $V_{REF}$
<b>SETV, SETI (MAX1648)</b>					
SETV Input Bias Current				1	$\mu A$
SETI Input Bias Current				5	$\mu A$
<b>LOGIC LEVELS (MAX1647)</b>					
SDA, SCL Input Low Voltage				0.8	V
SDA, SCL Input High Voltage		2.8			V
SDA, SCL Input Bias Current		-1		+1	$\mu A$
SDA Output Low Sink Current	$V_{SDA} = 0.6V$	6			mA

# Chemistry-Independent Battery Chargers

MAX1647/MAX1648

## TIMING CHARACTERISTICS—MAX1647

( $T_A = 0^{\circ}\text{C}$  to  $+85^{\circ}\text{C}$ , unless otherwise noted.)

PARAMETER	SYMBOL	CONDITIONS	MIN	TYP	MAX	UNITS
SCL Serial-Clock High Period	$t_{\text{HIGH}}$		4			$\mu\text{s}$
SCL Serial-Clock Low Period	$t_{\text{LOW}}$		4.7			$\mu\text{s}$
Start-Condition Setup Time	$t_{\text{SU:STA}}$		4.7			$\mu\text{s}$
Start-Condition Hold Time	$t_{\text{HD:STA}}$		4			$\mu\text{s}$
SDA Valid to SCL Rising-Edge Setup Time, Slave Clocking in Data	$t_{\text{SU:DAT}}$		250			ns
SCL Falling Edge to SDA Transition	$t_{\text{HD:DAT}}$		0			ns
SCL Falling Edge to SDA Valid, Master Clocking in Data	$t_{\text{DV}}$				1	$\mu\text{s}$

## TIMING CHARACTERISTICS—MAX1647

( $T_A = -40^{\circ}\text{C}$  to  $+85^{\circ}\text{C}$ , unless otherwise noted. Limits over this temperature range are guaranteed by design.)

PARAMETER	SYMBOL	CONDITIONS	MIN	TYP	MAX	UNITS
SCL Serial-Clock High Period	$t_{\text{HIGH}}$		4			$\mu\text{s}$
SCL Serial-Clock Low Period	$t_{\text{LOW}}$		4.7			$\mu\text{s}$
Start-Condition Setup Time	$t_{\text{SU:STA}}$		4.7			$\mu\text{s}$
Start-Condition Hold Time	$t_{\text{HD:STA}}$		4			$\mu\text{s}$
SDA Valid to SCL Rising-Edge Setup Time, Slave Clocking in Data	$t_{\text{SU:DAT}}$		250			ns
SCL Falling Edge to SDA Transition	$t_{\text{HD:DAT}}$		0			ns
SCL Falling Edge to SDA Valid, Master Clocking in Data	$t_{\text{DV}}$				1	$\mu\text{s}$

# Chemistry-Independent Battery Chargers

## Typical Operating Characteristics

(Circuit of Figure 3,  $T_A = +25^\circ\text{C}$ , unless otherwise noted.)

**MAX1647  
BATT LOAD TRANSIENT**

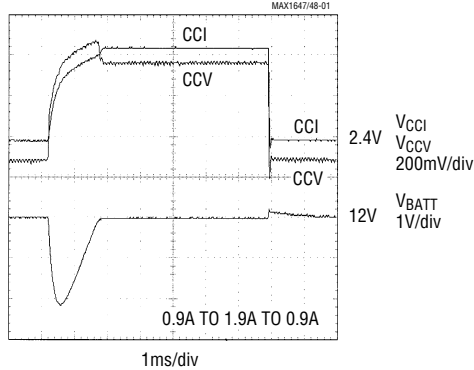

ChargingVoltage( ) = 0x2EE0 = 12000mV  
 ChargingCurrent( ) = 0xFFFF = MAX VALUE  
 ACDCIN = 18.0V, SEL = OPEN, R1 = 0.1 $\Omega$   
 R2 = 10k $\Omega$ , C1 = 68 $\mu\text{F}$ , C2 = 0.1 $\mu\text{F}$ , C3 = 47nF  
 L1 = 22 $\mu\text{H}$ , VREF = 4.096V

**MAX1647  
BATT LOAD TRANSIENT**

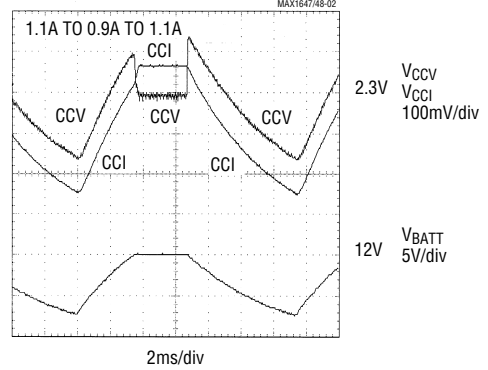

ChargingVoltage( ) = 0x2EE0 = 12000mV  
 ChargingCurrent( ) = 0x03E8 = 1000mA  
 ACDCIN = 18.0V, SEL = OPEN, C1 = 68 $\mu\text{F}$ ,  
 C2 = 0.1 $\mu\text{F}$ , C3 = 47nF, R1 = 0.1 $\Omega$   
 R2 = 10k $\Omega$ , L1 = 22 $\mu\text{H}$ , VREF = 4.096V

**VL VOLTAGE vs. LOAD CURRENT**

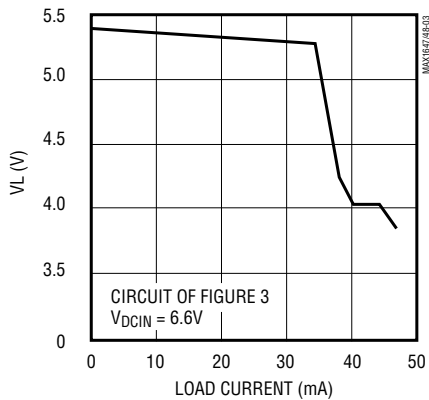

**INTERNAL REFERENCE VOLTAGE**

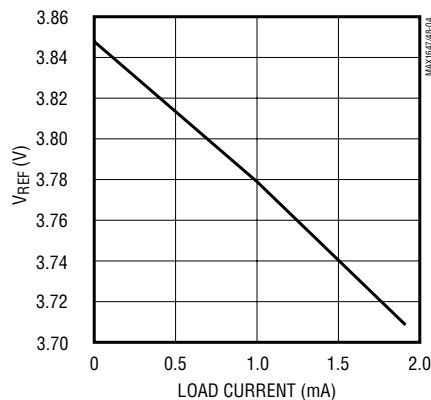

**INPUT AND OUTPUT POWER**

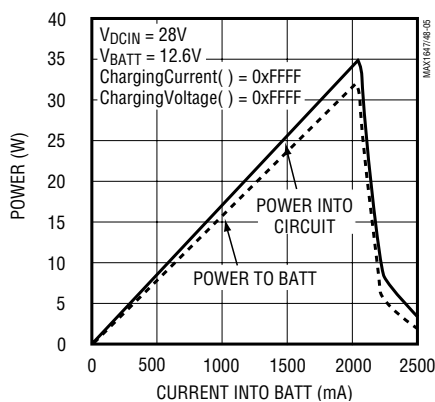

**MAX1647  
OUTPUT V-I CHARACTERISTIC**

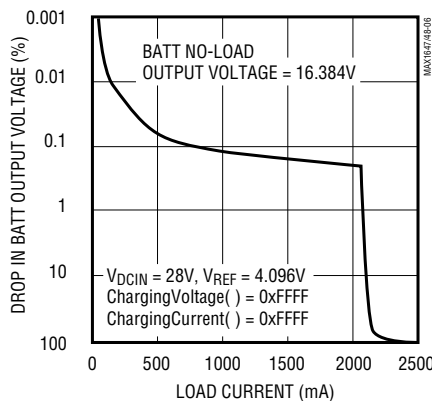

**OUTPUT VOLTAGE ERROR**

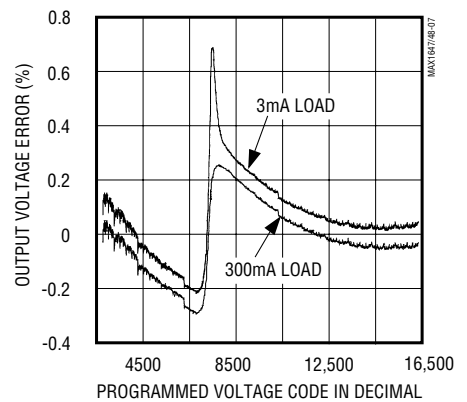

# Chemistry-Independent Battery Chargers

## Pin Description

**MAX1647/MAX1648**

PIN		NAME	FUNCTION
MAX1647	MAX1648		
1	—	IOUT	Linear Current-Source Output
2	1	DCIN	Input Voltage for Powering Charger
3	2	VL	Chip Power Supply. 5.4V linear regulator output from DCIN.
4	3	CCV	Voltage-Regulation-Loop Compensation Point
5	4	CCI	Current-Regulation-Loop Compensation Point
6	—	SEL	Current-Range Selector. Tying SEL to VL sets a 4A full-scale current. Leaving SEL open sets a 2A full-scale current. Tying SEL to AGND sets a 1A full-scale current.
7	5	CS	Current-Sense Positive Input
8	6	BATT	Battery Voltage Input and Current-Sense Negative Input
9	7	REF	3.9V Reference Voltage Output or External Reference Input
10	8	AGND	Analog Ground
—	10	SETI	Current-Regulation-Loop Set Point
11	—	$\overline{\text{INT}}$	Open-Drain Interrupt Output
—	11	SETV	Voltage-Regulation-Loop Set Point
12	9	THM	Thermistor Sense Voltage Input
13	—	SCL	Serial Clock
14	—	SDA	Serial Data
15	—	DACV	Voltage DAC Output
16	12	PGND	Power Ground
17	13	DLO	Low-Side Power MOSFET Driver Output
18	14	DHI	High-Side Power MOSFET Driver Output
19	15	LX	Power Connection for the High-Side Power MOSFET Driver
20	16	BST	Power Connection for the High-Side Power MOSFET Driver

# Chemistry-Independent Battery Chargers

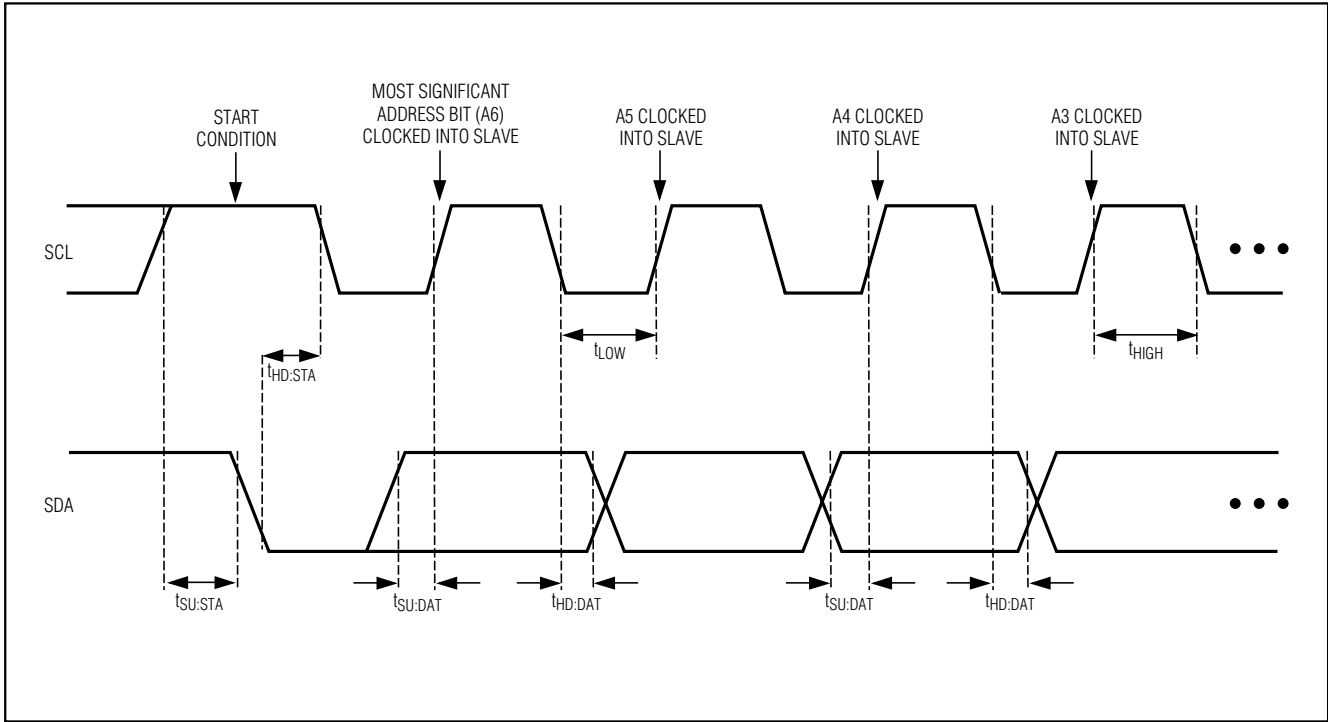

Figure 1. SMBus Serial Interface Timing—Address

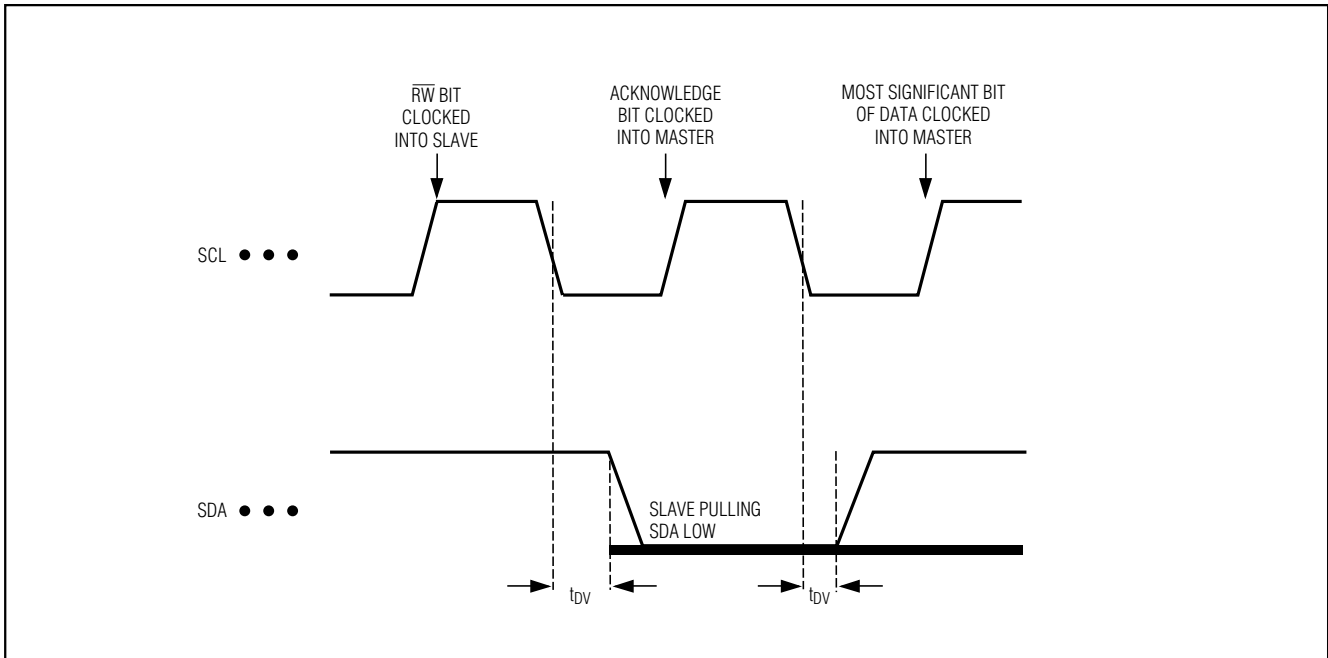

Figure 2. SMBus Serial Interface Timing—Acknowledge

# Chemistry-Independent Battery Chargers

MAX1647/MAX1648

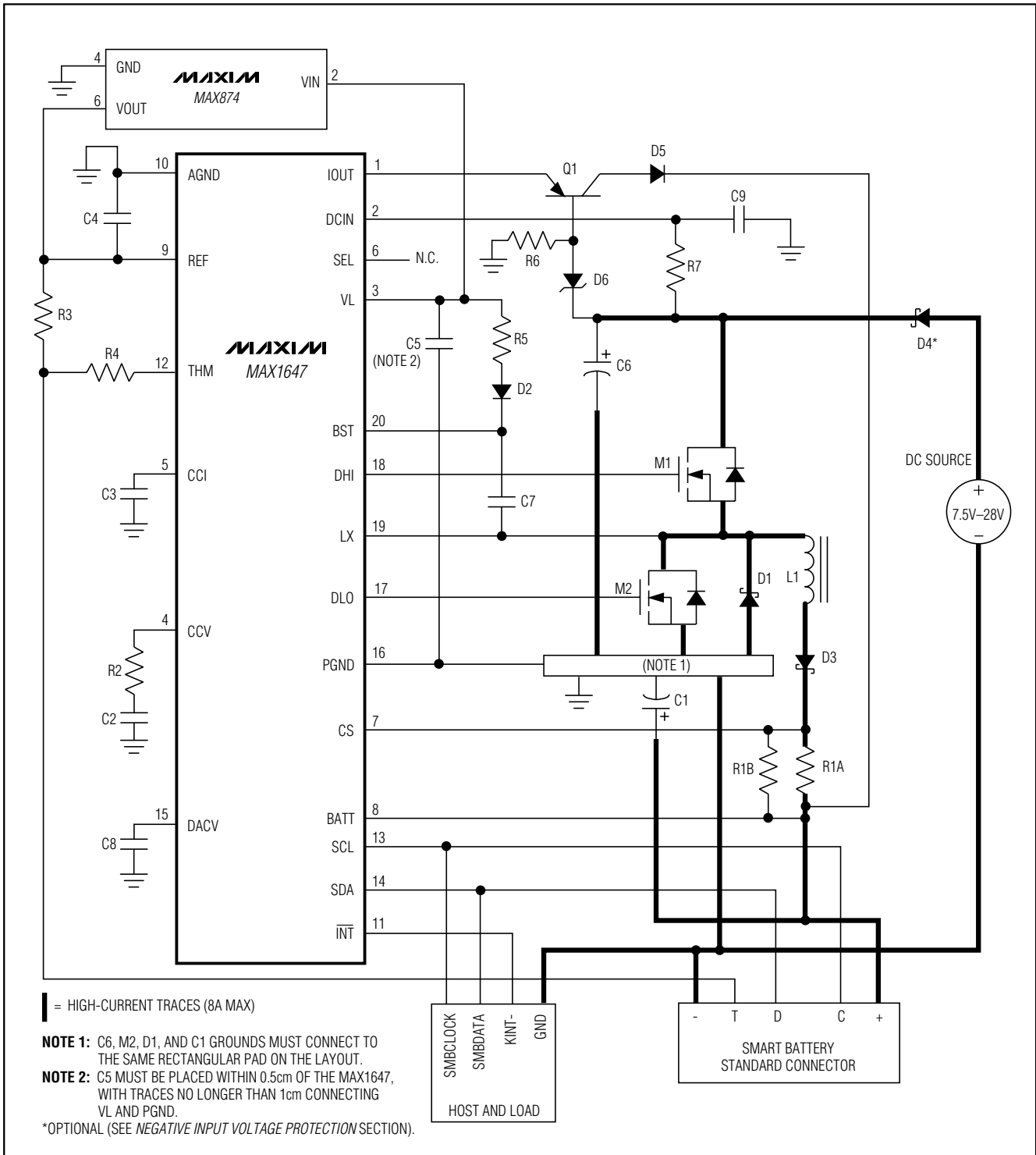

Figure 3. MAX1647 Typical Application Circuit

# Chemistry-Independent Battery Chargers

MAX1647/MAX1648

Table 1a. Component Selection for Figure 3 Circuit (Also Use for Figure 4)

DESIGNATION	QTY	UNITS	NOTES	SOURCE/TYPE
C1	47	$\mu\text{F}$	20V, ESR at 250kHz $\leq 0.4\Omega$	Sprague, 595D476X0020D7T, D case AVX, TPSE476M020R0150, E case
C2, C4, C7, C9	0.1	$\mu\text{F}$		
C3	47	nF		
C5	1	$\mu\text{F}$	10V, ceramic or low ESR	
C6	22	$\mu\text{F}$	35V	
C8	22	nF	10V	
D1, D3, D4			3A $I_{DC}$ , 30V Schottky diode, $P_D > 0.8\text{W}$ , 1N5821 equivalent	NIEC, NSQ03A04, FLAT-PAK (SMC) NIEC, 30VQ04F, TO-252AA (SMD) Motorola, MBRS340T3, SMC Motorola, MBRD340T4, DPAK Diodes Inc., SK33, SMC IR, 30BQ040, SMC
D2, D5			50mA $I_{DC}$ , 40V fast-recovery diode, 1N4150 equivalent	
D6			4.3V zener diode, 1N4731 or equivalent	
L1	22	$\mu\text{H}$	$\pm 20\%$ , 3A $I_{SAT}$ Note: size in L x W x H	Sumida, RCH-110/220M, 10mm x 10mm x 10mm Coiltronics, UP2-220, 0.541" x 0.345" x 0.231" Coilcraft, DO3340P-223, 0.510" x 0.370" x 0.450" Coilcraft, DO5022P-223, 0.730" x 0.600" x 0.280"
M1			$R_{DS, ON} \leq 0.1\Omega$ , $V_{DSS} \geq 30\text{V}$ , $P_D > 0.5\text{W}$ , logic level, N-channel power MOSFET	Motorola, MMSF5N03HD, SO-8 Motorola, MMDF3N03HD, SO-8 Motorola, MTD20N03HDL, DPAK IR, IRF7201, SO-8 IR, IRF7303, SO-8 IR, IRF7603, Micro8 Siliconix, Si9410DY, SO-8 Siliconix, Si9936DY, SO-8 Siliconix, Si6954DQ, TSSOP-8
M2			$R_{DS, ON} \leq 10\Omega$ , $V_{DSS} \geq 30\text{V}$ , logic level, N-channel power MOSFET, 2N7002 equivalent	Motorola, 2N7002LT1, SOT23 Motorola, MMBF170LT1, SOT23 Diodes Inc., 2N7002, SOT23 Diodes Inc., BS870, SOT23 Zetex, ZVN3306F, SOT23 Central Semiconductor, 2N7002, SOT23
Q1			$V_{CE, MAX} \leq -30\text{V}$ , 50mA $I_C$ , CONT, 2N3906 equivalent	
R1A	100	$\text{m}\Omega$	$\pm 1\%$ , 1W	IRC, CHP1100R100F13, 2512 IRC, LR251201R100F, 2512 Dale, WSL-2512/0.1 $\Omega$ / $\pm 1\%$ , 2512
R1B	1	$\Omega$	$\pm 5\%$ , 1/8W	
R2, R4	10	$\text{k}\Omega$	$\pm 5\%$ , 1/16W	
R3	10	$\text{k}\Omega$	$\pm 1\%$ , 1/16W	
R5, R7	10	$\Omega$	$\pm 5\%$ , 1/16W	
R6	10	$\text{k}\Omega$	$\pm 5\%$ , 1/8W	

# Chemistry-Independent Battery Chargers

**Table 1b. Component Suppliers**

MANUFACTURER	PHONE	FAX
AVX	803-946-0690	803-626-3123
Central Semiconductor	516-435-1110	516-435-1824
Coilcraft	847-639-6400	847-639-1469
Coiltronics	561-241-7876	561-241-9339
Dale	605-668-4131	605-665-1627
IR	310-322-3331	310-322-3332
IRC	512-992-7900	512-992-3377
NIEC	805-867-2555	805-867-2698
Siliconix	408-988-8000	408-970-3950
Sprague	603-224-1961	603-224-1430
Sumida	847-956-0666	847-956-0702
Zetex	516-543-7100	516-864-7630

## Detailed Description

### Output Characteristics

The MAX1647/MAX1648 contain both a voltage-regulation loop and a current-regulation loop. Both loops operate independently of each other. The voltage-regulation loop monitors BATT to ensure that its voltage never exceeds the voltage set point (V0). The current-regulation loop monitors current delivered to BATT to ensure that it never exceeds the current-limit set point (I0). The current-regulation loop is in control as long as BATT voltage is below V0. When BATT voltage reaches V0, the current loop no longer regulates, and the voltage-regulation loop takes over. Figure 5 shows the V-I characteristic at the BATT pin.

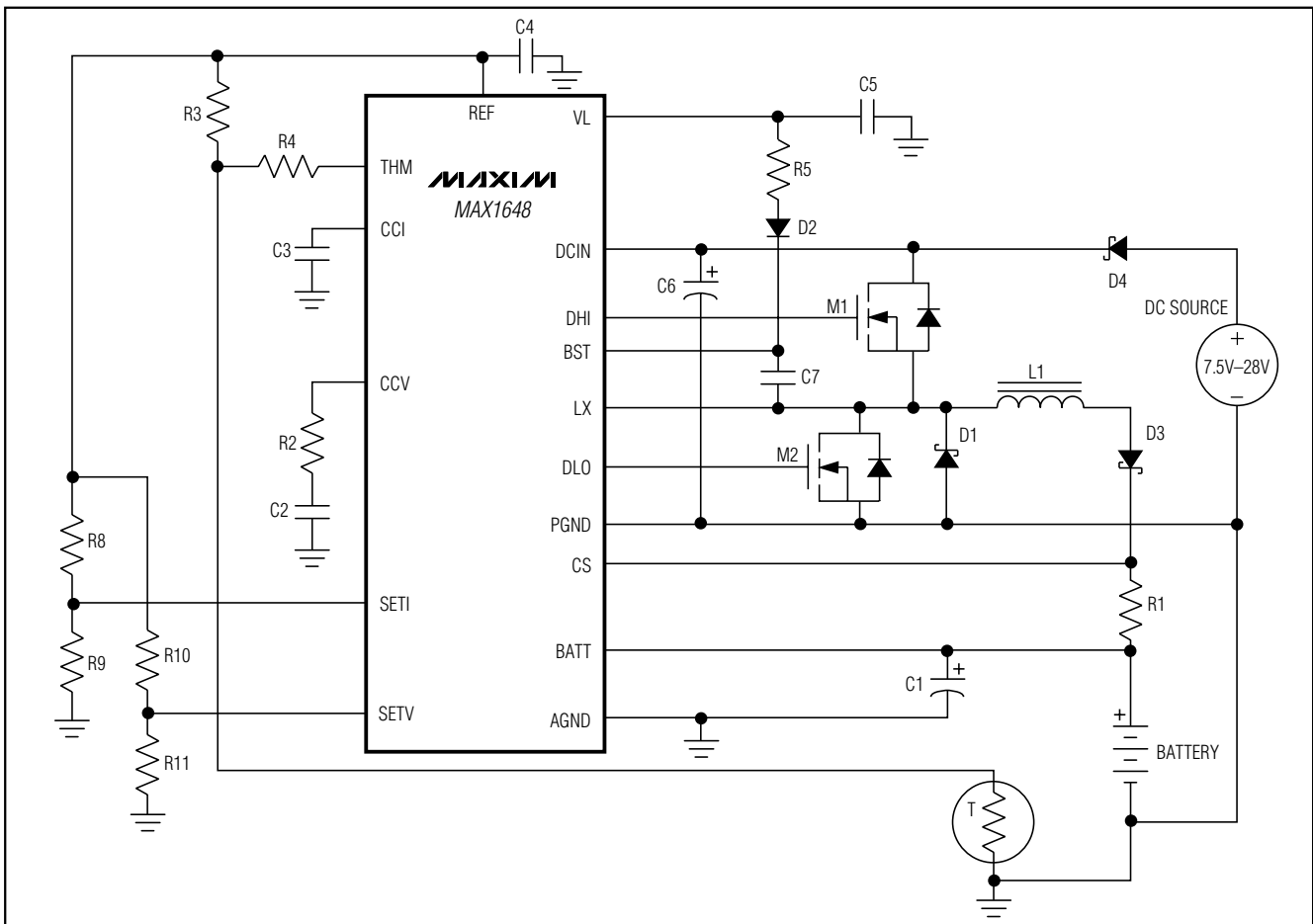

Figure 4. MAX1648 Typical Operating Circuit

# Chemistry-Independent Battery Chargers

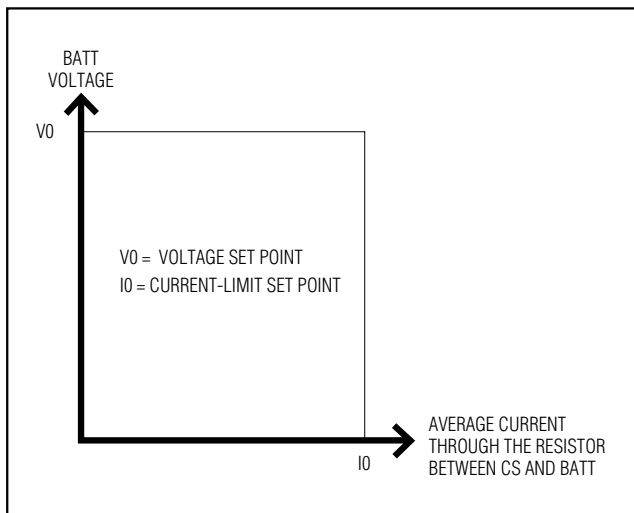

Figure 5. Output V-I Characteristic

### Setting V0 and I0 (MAX1647)

Set the MAX1647's voltage and current-limit set points through the Intel System Management Bus (SMBus) 2-wire serial interface. The MAX1647's logic interprets the serial-data stream from the SMBus interface to set internal digital-to-analog converters (DACs) appropriately. See the *MAX1647 Logic* section for more information.

### Setting V0 and I0 (MAX1648)

Set the MAX1648's voltage- and current-limit set points (V0 and I0, respectively) using external resistive dividers. Figure 6b is the MAX1648 block diagram. V0 equals four times the voltage on the SETV pin. I0 equals the voltage on SETI divided by 5.5, divided by R1 (Figure 4).

## Analog Section

The MAX1647/MAX1648 analog section consists of a current-mode PWM controller and two transconductance error amplifiers: one for regulating current and the other for regulating voltage. The MAX1647 uses DACs to set the current and voltage level, which are controlled through the SMBus interface. The MAX1648 eliminates the DACs and controls the error amplifiers directly from SETI (for current) and SETV (for voltage). Since separate amplifiers are used for voltage and current control, both control loops can be compensated separately for optimum stability and response in each state. The following discussion relates to the MAX1647; however, MAX1648 operation can easily be inferred from the MAX1647.

Whether the MAX1647 is controlling the voltage or current at any time depends on the battery's state. If the battery has been discharged, the MAX1647's output reaches the current-regulation limit before the voltage limit, causing the system to regulate current. As the battery charges, the voltage rises until the voltage limit is reached, and the charger switches to regulating voltage. The transition from current to voltage regulation is done by the charger, and need not be controlled by the host.

### Voltage Control

The internal GMV amplifier controls the MAX1647's output voltage. The voltage at the amplifier's noninverting input amplifier is set by a 10-bit DAC, which is controlled by a `ChargingVoltage()` command on the SMBus (see the *MAX1647 Logic* section for more information). The battery voltage is fed to the GMV amplifier through a 4:1 resistive voltage divider. With an external 4.096V reference, the set voltage ranges between 0 and 16.38V with 16mV resolution.

This poses a challenge for charging four lithium-ion cells in series: because the lithium-ion battery's typical per-cell voltage is 4.2V maximum, 16.8V is required. A larger reference voltage can be used to circumvent this. Under this condition, the maximum battery voltage no longer matches the programmed voltage. The solution is to use a 4.2V reference and host software. Contact Maxim's applications department for more information.

The GMV amplifier's output is connected to the CCV pin, which compensates the voltage-regulation loop. Typically, a series-resistor/capacitor combination can be used to form a pole-zero couplet. The pole introduced rolls off the gain starting at low frequencies. The zero of the couplet provides sufficient AC gain at mid-frequencies. The output capacitor then rolls off the mid-frequency gain to below 1, to guarantee stability before encountering the zero introduced by the output capacitor's equivalent series resistance (ESR). The GMV amplifier's output is internally clamped to between one-fourth and three-fourths of the voltage at REF.

### Current Control

The internal GMI amplifier and an internal current source control the battery current while the charger is regulating current. Since the regulator current's accuracy is not adequate to ensure full 11-bit accuracy, an internal linear current source is used in conjunction with the PWM regulator to set the battery current. The current-control DAC's five least significant bits set the

# Chemistry-Independent Battery Chargers

**MAX1647/MAX1648**

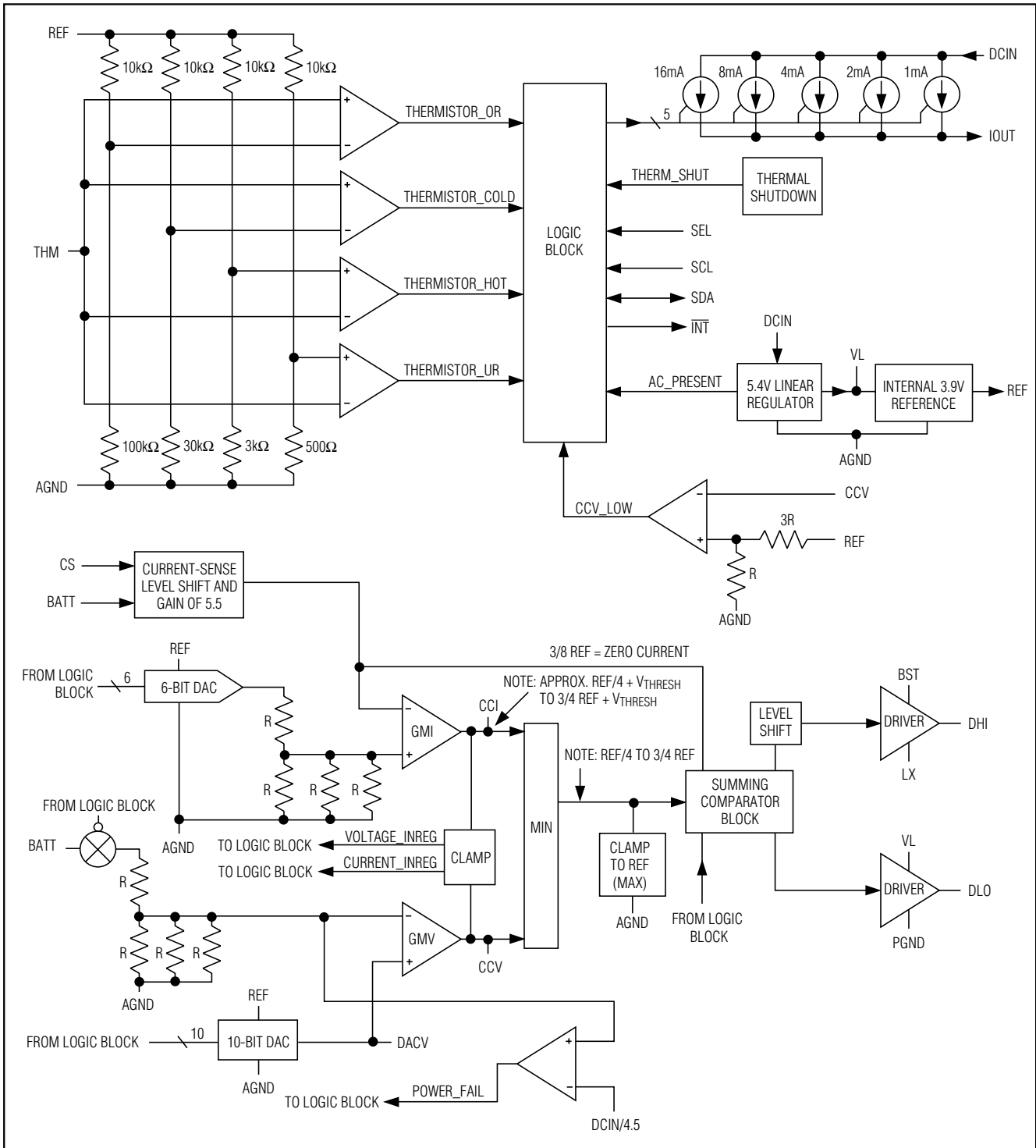

Figure 6a. MAX1647 Block Diagram

# Chemistry-Independent Battery Chargers

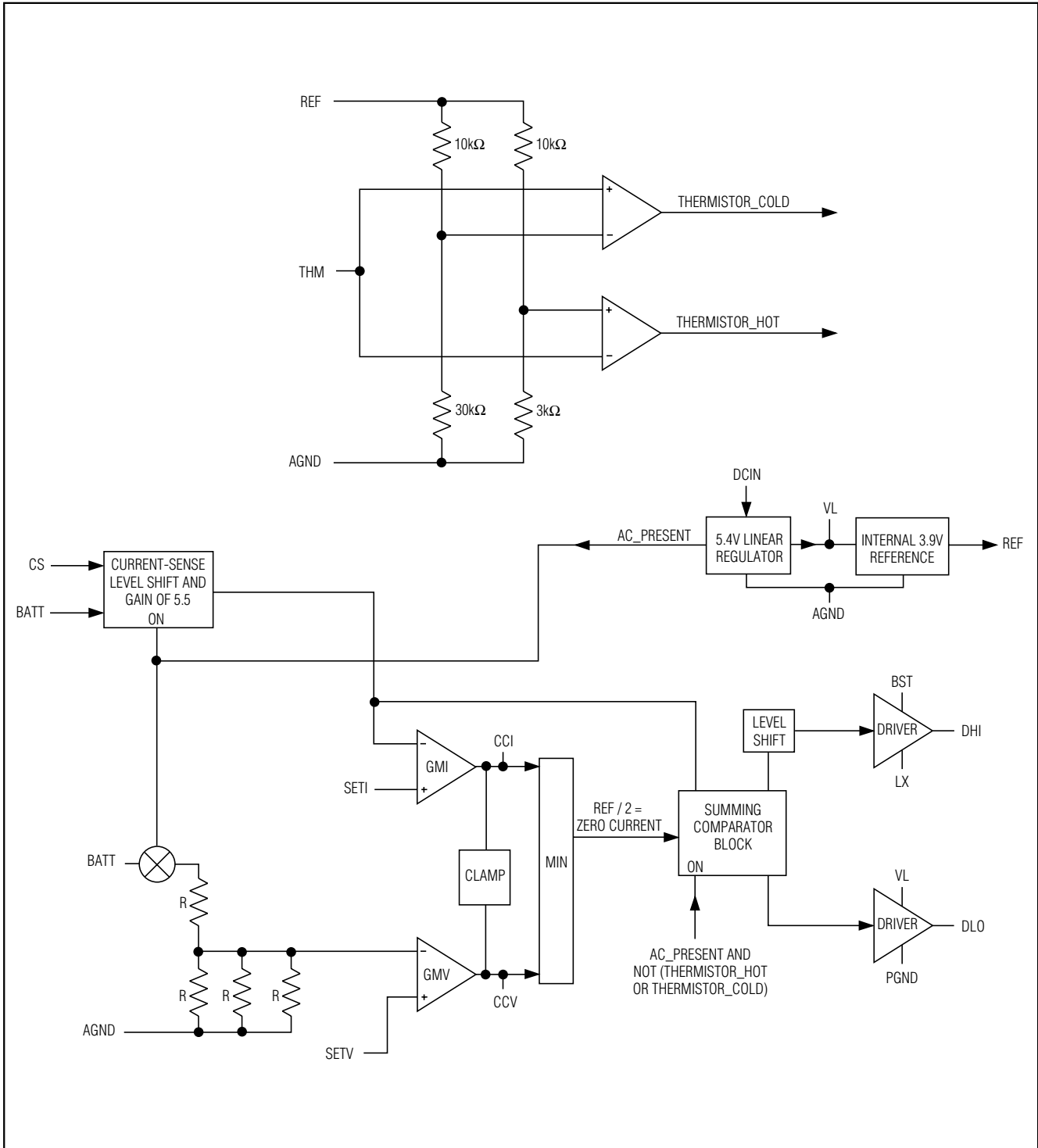

Figure 6b. MAX1648 Block Diagram

# Chemistry-Independent Battery Chargers

internal current sources' state, and the six most significant bits control the switching regulator's current. The internal current source supplies 1mA resolution to the battery to comply with the smart-battery specification. When the current is set to a number greater than 32, the internal current source remains at 31mA. This guarantees that battery-current setting is monotonic regardless of current-sense resistor choice and current-sense amplifier offset.

The GMI amplifier's noninverting input is driven by a 4:1 resistive voltage divider, which is driven by the 6-bit DAC. If an external 4.096V reference is used, this input is approximately 1.0V at full scale, and the resolution is 16mV. The current-sense amplifier drives the inverting input to the GMI amplifier. It measures the voltage across the current-sense resistor ( $R_{SEN}$ ) (which is between the CS and BATT pins), amplifies it by approximately 5.45, and level shifts it to ground. The full-scale current is approximately  $0.2V / R_{SEN}$ , and the resolution is  $3.2mV / R_{SEN}$ .

The current-regulation-loop is compensated by adding a capacitor to the CCI pin. This capacitor sets the current-feedback loop's dominant pole. The GMI amplifier's output is clamped to between approximately one-fourth and three-fourths of the REF voltage. While the current is in regulation, the CCV voltage is clamped to within 80mV of the CCI voltage. This prevents the battery voltage from overshooting when the DAC voltage setting is updated. The converse is true when the voltage is in regulation and the current is not at the current DAC setting. Since the linear range of CCI or CCV is about 1.5V to 3.5V or about 2V, the 80mV clamp results in a relatively negligible overshoot when the loop switches from voltage to current regulation or vice versa.

## PWM Controller

The battery voltage or current is controlled by the current-mode, pulse-width-modulated (PWM), DC-DC converter controller. This controller drives two external N-channel MOSFETs, which switch the voltage from the input source. This switched voltage feeds an inductor, which filters the switched rectangular wave. The controller sets the pulse width of the switched voltage so that it supplies the desired voltage or current to the battery.

The heart of the PWM controller is the multi-input comparator. This comparator sums three input signals to determine the pulse width of the switched signal, setting the battery voltage or current. The three signals are the current-sense amplifier's output, the GMV or GMI error amplifier's output, and a slope-compensation signal, which ensures that the controller's internal current-control loop is stable.

The PWM comparator compares the current-sense amplifier's output to the higher output voltage of either the GMV or the GMI amplifier (the error voltage). This current-mode feedback corrects the duty ratio of the switched voltage, regulating the peak battery current and keeping it proportional to the error voltage. Since the average battery current is nearly the same as the peak current, the controller acts as a transconductance amplifier, reducing the effect of the inductor on the output filter LC formed by the output inductor and the battery's parasitic capacitance. This makes stabilizing the circuit easy, since the output filter changes from a complex second-order RLC to a first-order RC. To preserve the inner current-control loop's stability, slope compensation is also fed into the comparator. This damps out perturbations in the pulse width at duty ratios greater than 50%.

At heavy loads, the PWM controller switches at a fixed frequency and modulates the duty cycle to control the battery voltage or current. At light loads, the DC current through the inductor is not sufficient to prevent the current from going negative through the synchronous rectifier (Figure 3, M2). The controller monitors the current through the sense resistor  $R_{SEN}$ ; when it drops to zero, the synchronous rectifier turns off to prevent negative current flow.

## MOSFET Drivers

The MAX1647 drives external N-channel MOSFETs to regulate battery voltage or current. Since the high-side N-channel MOSFET's gate must be driven to a voltage higher than the input source voltage, a charge pump is used to generate such a voltage. The capacitor C7 (Figure 3) charges to approximately 5V through D2 when the synchronous rectifier turns on. Since one side of C7 is connected to the LX pin (the source of M1), the high-side driver (DHI) can drive the gate up to the voltage at BST, which is greater than the input voltage, when the high-side MOSFET turns on.

The synchronous rectifier behaves like a diode, but with a smaller voltage drop to improve efficiency. A small dead time is added between the time that the high-side MOSFET turns off and the synchronous rectifier turns on, and vice versa. This prevents crowbar currents (currents that flow through both MOSFETs during the brief time that one is turning on and the other is turning off). Connect a Schottky rectifier from ground to LX (across the source and drain of M2) to prevent the synchronous rectifier's body diode from conducting. The body diode typically has slower switching-recovery times, so allowing it to conduct would degrade efficiency.

# Chemistry-Independent Battery Chargers

The synchronous rectifier may not be completely replaced by a diode because the BST capacitor charges while the synchronous rectifier is turned on. Without the synchronous rectifier, the BST capacitor may not fully charge, leaving the high-side MOSFET with insufficient gate drive to turn on. However, the synchronous rectifier can be replaced with a small MOSFET, such as a 2N7002, to guarantee that the BST capacitor is allowed to charge. In this case, most of the current at high currents is carried by the diode and not by the synchronous rectifier.

## Internal Regulator and Reference

The MAX1647 uses an internal low-dropout linear regulator to create a 5.4V power supply (VL), which powers its internal circuitry. VL can supply up to 20mA. A portion of this current powers the internal circuitry, but the remaining current can power the external circuitry. The current used to drive the MOSFETs comes from this supply, which must be considered when calculating how much power can be drawn. To estimate the current required to drive the MOSFETs, multiply the total gate charge of each MOSFET by the switching frequency (typically 250kHz). The internal circuitry requires as much as 6mA from the VL supply. To ensure VL stability, bypass the VL pin with a 1µF or greater capacitor.

The MAX1647 has an internal ±2% accurate 3.9V reference voltage. An external reference can be used to increase the charger's accuracy. Use a 4.096V reference, such as the MAX874, for compliance with the Intel/Duracell smart-battery specification. Voltage-setting accuracy is ±0.65%, so the total voltage accuracy is the accuracy added to the reference accuracy. For 1% total voltage accuracy, use a reference with ±0.35% or greater accuracy. If the internal reference is used, bypass it with a 0.1µF or greater capacitor.

## MAX1647 Logic

The MAX1647 uses serial data to control its operation. The serial interface complies with the SMBus specification (see *System Management Bus Specification*, from Intel Architecture Labs; <http://www.intel.com/IAL/power-mgm.html>; Intel Architecture Labs: 800-253-3696). Charger functionality complies with the Intel/Duracell Smart Charger Specification for a level 2 charger.

The MAX1647 uses the SMBus Read-Word and Write-Word protocols to communicate with the battery it is charging, as well as with any host system that monitors the battery to charger communications. The MAX1647 never initiates communication on the bus; it only receives commands and responds to queries for status information. Figure 7 shows examples of the SMBus Write-Word and Read-Word protocols.

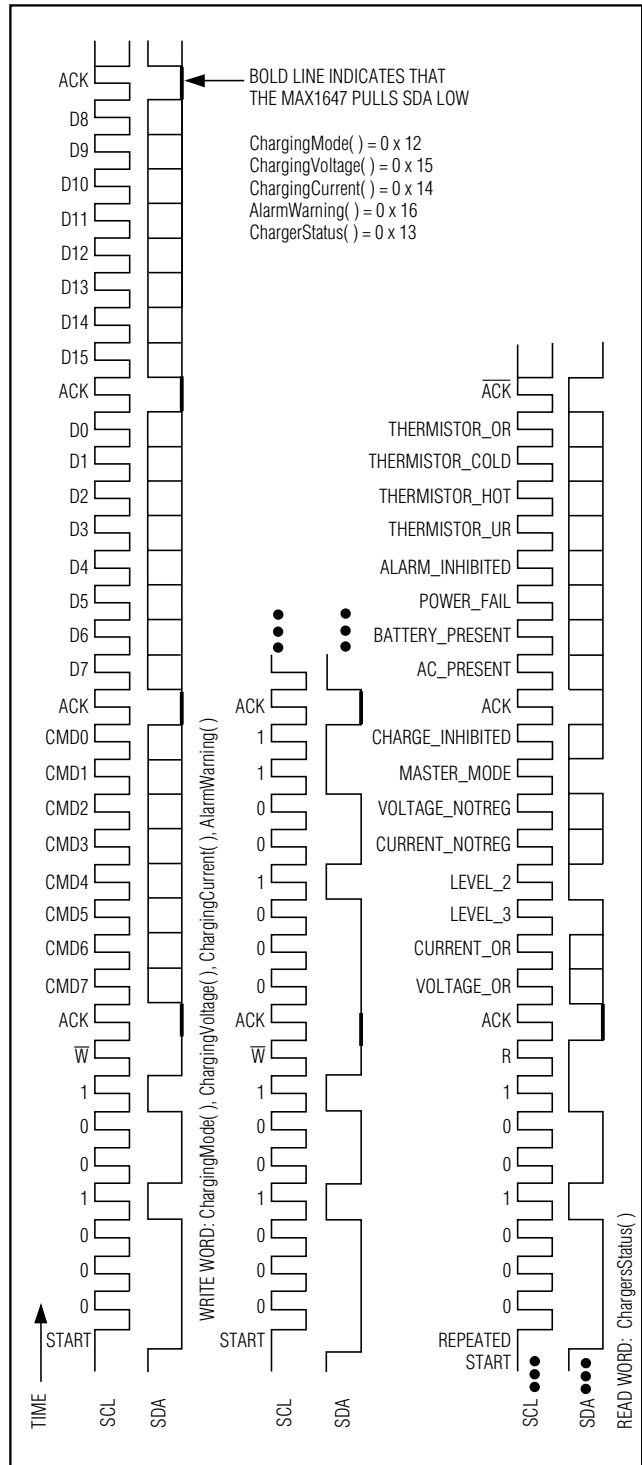

Figure 7. Write-Word and Read-Word Examples

# Chemistry-Independent Battery Chargers

Each communication with the MAX1647 begins with a start condition that is defined as a falling edge on SDA with SCL high. The device address follows the start condition. The MAX1647 device address is 0b0001001 (0b indicates a binary number), which may also be denoted as 0x12 (0x indicates a hexadecimal number) for Write-Word commands, or 0x13 in hexadecimal for Read-Word commands (note that the address is only seven bits, and the hexadecimal representation uses R/W as its least significant bit).

## ChargerMode( )

The ChargerMode( ) command uses Write-Word protocol. The command code for ChargerMode( ) is 0x12; thus the CMD7–CMD0 bits in Write-Word protocol should be 0b00010010. Table 2 describes the functions of the 16 different data bits (D0–D15). Bit 0 refers to the D0 bit in the Write-Word protocol (Figure 7).

Whenever the BATTERY\_PRESENT status bit is clear, the HOT\_STOP bit is set, regardless of any previous ChargerMode( ) command. To charge a battery that has a thermistor impedance in the HOT range (i.e., THERMISTOR\_HOT = 1 and THERMISTOR\_UR = 0), the host must use the ChargerMode( ) command to clear HOT\_STOP **after** the battery is inserted. The HOT\_STOP bit returns to its default power-up condition ('1') whenever the battery is removed.

## ChargingVoltage( )

The ChargingVoltage( ) command uses Write-Word protocol. The command code for ChargingVoltage( ) is 0x15; thus, the CMD7–CMD0 bits in Write-Word protocol should be 0b00010101. The 16-bit binary number formed by D15–D0 represents the voltage set point (V0) in millivolts; however, since the MAX1647 has only 16mV resolution in setting V0, the D0, D1, D2, and D3 bits are ignored. For D15 = D14 = 0:

$$\text{VOLTAGE\_OR} = 0 \text{ and } V0 \text{ (in Volts)} = 4 \times \text{REF} \times \frac{\text{VDAC}}{2^{10}}$$

In equation 1, VDACC is the decimal equivalent of the binary number represented by bits D13, D12, D11, D10, D9, D8, D7, D6, D5, and D4 programmed with the ChargingVoltage( ) command. For example, if D4–D13 are all set, VDACC is the decimal equivalent of 0b1111111111 (1023). If either D15 or D14, or both D15 and D14, are set, all the bits in the voltage DAC (Figure 6a) are set, regardless of D13–D0, and the status register's VOLTAGE\_OR bit is set. For D15 = 1 and/or D14 = 1:

$$\text{VOLTAGE\_OR} = 1 \text{ and } V0 \text{ (in Volts)} = 4 \times \text{REF} \times \frac{2^{10} - 1}{2^{10}}$$

**Table 2. ChargerMode( ) Bit Functions**

BIT NAME	BIT POSITION*	POR VALUE**	FUNCTION
INHIBIT_CHARGE	0	0	0 = Allow normal operation; clear the CHG_INHIBITED status bit. 1 = Turn the charger off; set the CHG_INHIBITED status bit.
ENABLE_POLLING	1	—	Not implemented. Write 0 into this bit.
POR_RESET	2	—	0 = No change in any non-ChargerMode( ) settings. 1 = Change the voltage and current settings to 0xFFFF and 0x00C0 respectively; clear the THERMISTOR_HOT and ALARM_INHIBITED bits.
RESET_TO_ZERO	3	—	Not implemented. Write 0 into this bit.
N/A	4, 7, 8, 9, 11–15	—	Not implemented. Write 1 into this bit.
BATTERY_PRESENT_MASK	5	0	0 = Interrupt on either edge of the BATTERY_PRESENT status bit. 1 = Do not interrupt because of a BATTERY_PRESENT bit change.
POWER_FAIL_MASK	6	1	0 = Interrupt on either edge of the POWER_FAIL status bit. 1 = Do not interrupt because of a POWER_FAIL bit change.
HOT_STOP	10	1	0 = The THERMISTOR_HOT status bit does not turn the charger off. 1 = THERMISTOR_HOT turns the charger off.

\*Bit position in the D15–D0 data.

\*\*Power-on reset value.

N/A = Not available.

# Chemistry-Independent Battery Chargers

Figure 8 shows the mapping between V0 (the voltage-regulation-loop set point) and the ChargingVoltage( ) data.

The power-on reset value for the ChargingVoltage( ) register is 0xFFF0; thus, the first time a MAX1647 is powered on, the BATT voltage regulates to 16.368V with VREF = 4.096V. Any time the BATTERY\_PRESENT status bit is clear, the ChargingVoltage( ) register returns to its power-on reset state.

## ChargingCurrent( )

The ChargingCurrent( ) command uses Write-Word protocol. The command code for ChargingCurrent( ) is 0x14; thus, the CMD7–CMD0 bits in Write-Word protocol should be 0b00010100. The 16-bit binary number formed by D15–D0 represents the current-limit set point (I0) in milliamps. Tying SEL to AGND selects a 1.023A maximum setting for I0. Leaving SEL open selects a 2.047A maximum setting for I0. Tying SEL to VL selects a 4.095A maximum setting for I0.

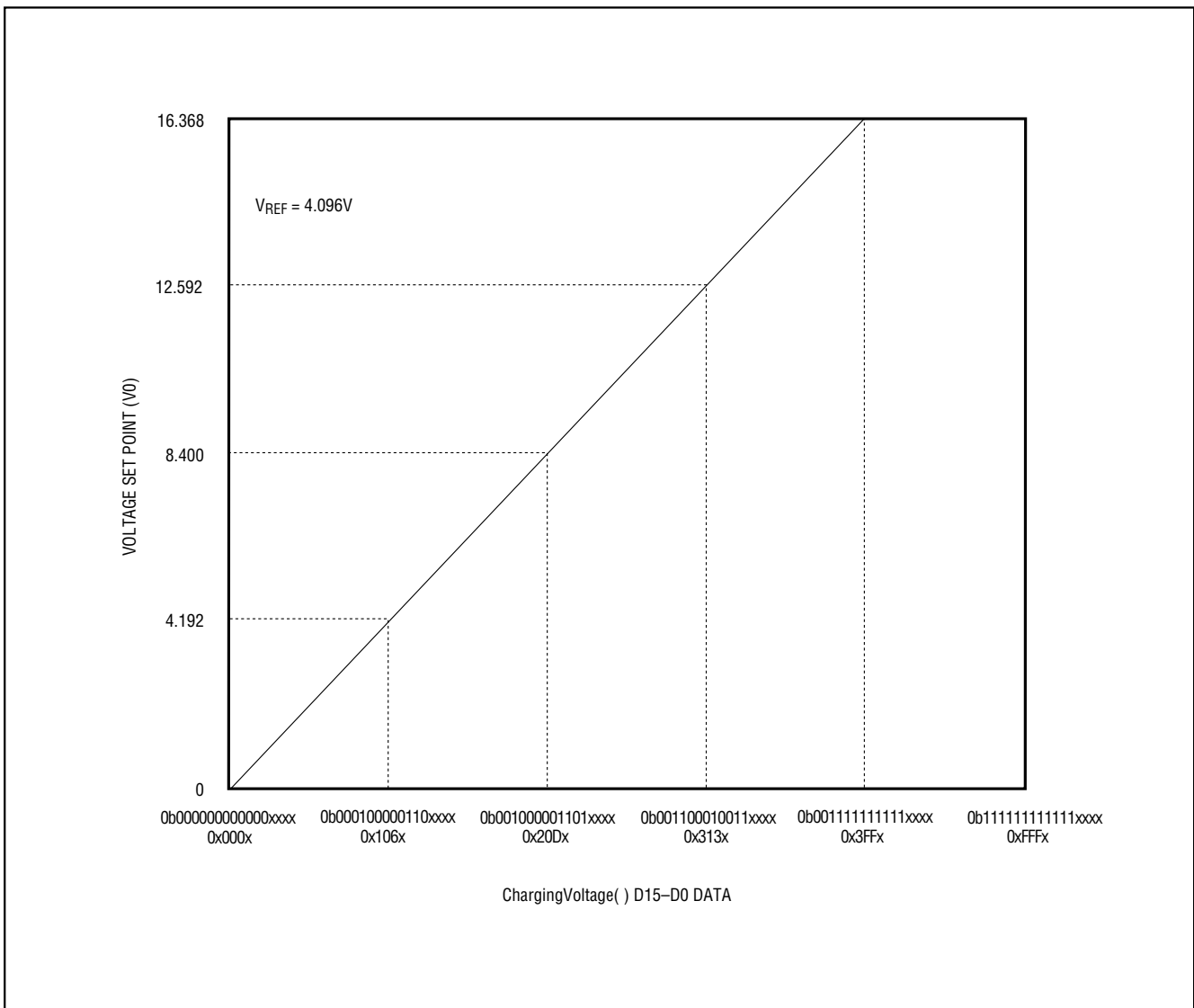

Figure 8. ChargingVoltage( ) Data to Voltage Mapping

# Chemistry-Independent Battery Chargers

Two sources of current in the MAX1647 charge the battery: a binary-weighted linear current source sources from IOUT, and a switching regulator controls the current flowing through the current-sense resistor (R1). IOUT provides a small maintenance charge current to compensate for battery self-discharge, while the switching regulator provides large currents for fast charging.

IOUT sources from 1mA to 31mA. Table 3 shows the relationship between the value programmed with the

ChargingCurrent( ) command and IOUT source current. The CCV\_LOW comparator checks to see if the output voltage is too high by comparing CCV to REF / 4. If CCV\_LOW = 1 (when CCV < REF / 4), IOUT shuts off, preventing the output voltage from exceeding the voltage set point specified by the ChargingVoltage( ) register. VOLTAGE\_NOTREG = 1 whenever the internal clamp pulls down on CCV. (The internal clamp pulls down on CCV to keep its voltage close to CCI's voltage.)

**Table 3. Relationship Between IOUT Source Current and ChargingCurrent( ) Value**

CHARGE_INHIBITED	(NOTE 1)	ALARM_INHIBITED	ChargingVoltage( )	ChargingCurrent( )	CCV_LOW	VOLTAGE_NOTREG	IOUT OUTPUT CURRENT
0	0	0	0x0010–0xFFFF	0x0001–0x001F	0	x	1mA–31mA
0	0	0	0x0010–0xFFFF	0x0001–0x001F	1	0	0mA
0	0	0	0x0010–0xFFFF	0x0001–0x001F	1	1	1mA–31mA
0	0	0	0x0010–0xFFFF	0x0020–0xFFFF	0	x	31mA
0	0	0	0x0010–0xFFFF	0x0020–0xFFFF	1	0	0mA
0	0	0	0x0010–0xFFFF	0x0020–0xFFFF	1	1	31mA
0	0	0	x	0x0000	x	x	0mA
0	0	0	0x0000–0x000F	x	x	x	0mA
0	x	1	x	x	x	x	0mA
0	1	x	x	x	x	x	0mA
1	x	x	x	x	x	x	0mA

**Note 1:** Logical AND of THERMISTOR\_HOT, HOT\_STOP, NOT(THERMISTOR\_UR).

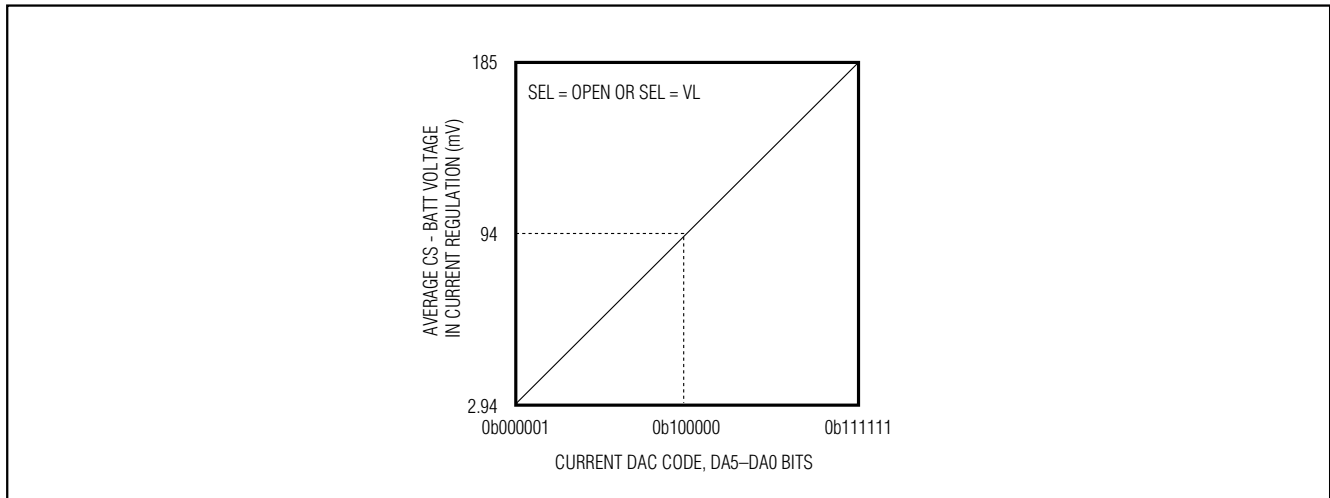

Figure 9. Average Voltage Between CS and BATT vs. Current DAC Code

# Chemistry-Independent Battery Chargers

**Table 4. Relationship Between Current DAC Code and the ChargingCurrent( ) Value**

CHARGE_INHIBITED	(NOTE 1)	ALARM_INHIBITED	ChargingVoltage( )	SEL	ChargingCurrent( )	CURRENT DAC CODE	SW REG ON?	(NOTE 2)
0	0	0	0x0010–0xFFFF	0V	0x0001–0x001F	0	No	0
0	0	0	0x0010–0xFFFF	0V	0x0020–0x003F	2	Yes	0
0	0	0	0x0010–0xFFFF	0V	0x0040–0x03DF	4–60	Yes	0
0	0	0	0x0010–0xFFFF	0V	0x03E0–0x03FF	62	Yes	0
0	0	0	0x0010–0xFFFF	0V	0x0400–0xFFFF	62	Yes	1
0	0	0	0x0010–0xFFFF	open	0x0001–0x001F	0	No	0
0	0	0	0x0010–0xFFFF	open	0x0020–0x003F	1	Yes	0
0	0	0	0x0010–0xFFFF	open	0x0040–0x07DF	2–62	Yes	0
0	0	0	0x0010–0xFFFF	open	0x07E0–0x07FF	63	Yes	0
0	0	0	0x0010–0xFFFF	open	0x0800–0xFFFF	63	Yes	1
0	0	0	0x0010–0xFFFF	VL	0x0001–0x001F	0	No	0
0	0	0	0x0010–0xFFFF	VL	0x0020–0x003F	1	Yes	0
0	0	0	0x0010–0xFFFF	VL	0x0040–0x007F	1	Yes	0
0	0	0	0x0010–0xFFFF	VL	0x0080–0x0F9F	2–62	Yes	0
0	0	0	0x0010–0xFFFF	VL	0x0FA0–0x0FBF	63	Yes	0
0	0	0	0x0010–0xFFFF	VL	0x0FC0–0x0FFF	63	Yes	0
0	0	0	0x0010–0xFFFF	VL	0x0001–0xFFFF	63	Yes	1
0	0	0	x	x	0x0000	0	No	0
0	0	0	0x0010–0xFFFF	x	x	N/C	No	N/C
0	x	1	x	x	x	N/C	No	N/C
0	1	x	x	x	x	N/C	No	N/C
1	x	x	x	x	x	N/C	No	N/C

**Note 1:** Logical AND of THERMISTOR\_HOT, HOT\_STOP, NOT(THERMISTOR\_UR).

**Note 2:** Value of CURRENT\_OR bit in the ChargerStatus( ) register.

N/C = No change.

**Table 5. Effect of SEL Pin-Strapping on the ChargingCurrent( ) Data Bits**

SEL	R1 (mΩ)	D15	D14	D13	D12	D11	D10	D9	D8	D7	D6	D5	D4	D3	D2	D1	D0
AGND	181	0	0	0	0	0	0	DA5	DA4	DA3	DA2	DA1	I4	I3	I2	I1	I0
Open	90	0	0	0	0	0	DA5	DA4	DA3	DA2	DA1	DA0	I4	I3	I2	I1	I0
VL	45	0	0	0	0	DA5	DA4	DA3	DA2	DA1	DA0	*	I4	I3	I2	I1	I0

\*When SEL = VL, D5 = 1 forces DA0 to be 1 regardless of the D6 bit value.

With the switching regulator on, the current through R1 (Figure 3) is regulated by sensing the average voltage between CS and BATT. A 6-bit current DAC controls the current-limit set point. DA5–DA0 denote the bits in the current DAC code. Figure 9 shows the relationship between the current DAC code and the average voltage between CS and BATT.

When the switching regulator is off, DHI is forced to LX and DLO is forced to ground. This prevents current from flowing through inductor L1. Table 4 shows the relationship between the ChargingCurrent( ) register value and the switching regulator current DAC code.

# Chemistry-Independent Battery Chargers

With SEL = AGND, R1 should be as close as possible to  $0.185 / 1.023 = 181\text{m}\Omega$  to ensure that the actual output current matches the data value programmed with the ChargingCurrent( ) command. With SEL = open, R1 should be as close as possible to  $90\text{m}\Omega$ . With SEL = VL, R1 should be as close as possible to  $45\text{m}\Omega$ . Table 5 summarizes how SEL affects the R1 value and the meaning of data bits D15–D0 in the ChargingCurrent( ) command. DA5–DA0 denote the current DAC code bits, and I4–I0 denote the IOUT linear-current source binary weighting bits. Note that whenever any current DAC bits are set, the linear-current source is set to full scale (31mA).

The power-on reset value for the ChargingCurrent( ) register is 0x000C. Irrespective of the SEL pin setting, the MAX1647 powers on with I0 set to 12mA (i.e., DA5–DA0, I1, and I0 all equal to zero, and only I3 and I2 set). Anytime the BATTERY\_PRESENT status bit is clear (battery removed), the ChargingCurrent( ) register returns to its power-on reset state. This ensures that upon insertion of a battery, the initial charging current is 12mA.

### AlarmWarning( )

The AlarmWarning( ) command uses Write-Word protocol. The command code for AlarmWarning( ) is 0x16; thus the CMD7–CMD0 in Write-Word protocol should be 0b00010110. The AlarmWarning( ) command sets the ALARM\_INHIBITED status bit in the MAX1647 if D15, D14, or D12 of the Write-Word protocol data equals 1. Table 6 summarizes the AlarmWarning( ) command's function. The ALARM\_INHIBITED status bit remains set until BATTERY\_PRESENT = 0 (battery removed) or a ChargerMode( ) command is written with the POR\_RESET bit set. As long as ALARM\_INHIBITED = 1, the MAX1647 switching regulator and IOUT current source remain off.

### ChargerStatus( )

The ChargerStatus( ) command uses Read-Word protocol. The command code for ChargerStatus( ) is 0x13; thus, the CMD7–CMD0 bits in Write-Word protocol should be 0b00010011. The ChargerStatus( ) command returns information about thermistor impedance and the MAX1647's internal state. The Read-Word

protocol returns D15–D0 (Figure 7). Table 7 describes the meaning of the individual bits. The latched bits, THERMISTOR\_HOT and ALARM\_INHIBITED, are cleared whenever BATTERY\_PRESENT = 0 or ChargerMode( ) is written with POR\_RESET = 1.

### Interrupts and the Alert-Response Address

An interrupt is triggered ( $\overline{\text{INT}}$  goes low) whenever power is applied to DCIN, the BATTERY\_PRESENT bit changes, or the POWER\_FAIL bit changes. BATTERY\_PRESENT and POWER\_FAIL have interrupt masks that can be set or cleared via the ChargerMode( ) command.  $\overline{\text{INT}}$  stays low until the interrupt is cleared. There are two methods for clearing the interrupt: issuing a ChargerStatus( ) command, and using the Receive Byte protocol with a 0x19 Alert-Response address. The MAX1647 responds to the Alert-Response address with the 0x89 byte.

### Applications Information

#### Using the MAX1647 with Duracell Smart Batteries

The following pseudo-code describes an interrupt routine that is triggered by the MAX1647  $\overline{\text{INT}}$  output going low. This interrupt routine keeps the host informed of any changes in battery-charger status, such as DCIN power detection, or battery removal and insertion.

```

DOMAX1647:
{ This is the beginning of the routine that handles
MAX1647 interrupts. }
{ Check the status of the MAX1647. }
TEMPWORD = ReadWord( SMBADDR = 0b00010011
= 0x13, COMMAND = 0x13 )
{ Check for the normal power-up case without a battery
installed. THERMISTOR_OR = 1, BATTERY_PRESENT =
0. Use 0b1011111011111111 = 0xBEFF as the mask. }
IF (TEMPWORD OR 0xBEFF) = 0xBFFF THEN GOTO
NOBATT:
{ Check to see if the battery is installed. BATTERY_
PRESENT = 1. Use 0b1011111111111111 = 0xBFFF as
the mask. }
    
```

**Table 6. Effect of the AlarmWarning( ) Command**

AlarmWarning( ) WRITE-WORD PROTOCOL DATA																RESULT
D15	D14	D13	D12	D11	D10	D9	D8	D7	D6	D5	D4	D3	D2	D1	D0	
1	x	x	x	x	x	x	x	x	x	x	x	x	x	x	x	Set ALARM_INHIBITED
x	1	x	x	x	x	x	x	x	x	x	x	x	x	x	x	Set ALARM_INHIBITED
x	x	x	1	x	x	x	x	x	x	x	x	x	x	x	x	Set ALARM_INHIBITED

# Chemistry-Independent Battery Chargers

**IF (TEMPWORD OR 0xBEFF) = 0xFFFF THEN GOTO**

**HAVEBATT:**

**GOTO ENDINT:**

*HAVEBATT:*

{ A battery is installed. Turn the battery's broadcast mode off to monitor the charging process. Using the BatteryMode( ) command, make sure the CHARGER\_MODE bit is set. }

**WriteWord(SMBADDR = 0b00010110 = 0x16, COMMAND = 0X03, DATA = 0x4000)**

**GOTO ENDINT:**

*NOBATT:*

{ Notify the system that AC power is present, but no battery is present. }

**GOTO ENDINT:**

*ENDINT:*

{ This is the end of the interrupt routine. }

The following pseudo-code describes a polling routine that queries the battery for its desired charge voltage and charge current, checks to make sure that the requested charge current and charge voltage are valid, and instructs the MAX1647 to comply with the request.

*DOPOLLING:*

{ This is the beginning of the polling routine. }

{ Ask the battery what voltage it wants using the battery's ChargingVoltage( ) command. }

**TEMPVOLTAGE = ReadWord( SMBADDR = 0b00010111 = 0x17, COMMAND = 0x15 )**

{ Ask the battery what current it wants using the battery's ChargingCurrent( ) command. }

**TEMPCURRENT = ReadWord( SMBADDR = 0b00010111 = 0x17, COMMAND = 0x14 )**

{ Now the routine can check that the TEMPVOLTAGE and TEMPCURRENT values make sense and that the battery is not malfunctioning. }

{ With valid TEMPVOLTAGE and TEMPCURRENT values, instruct the MAX1647 to comply with the request. }

**WriteWord( SMBADDR = 0b00010010 = 0x12, COMMAND = 0x15, DATA = TEMPVOLTAGE )**

**WriteWord( SMBADDR = 0b00010010 = 0x12, COMMAND = 0x14, DATA = TEMPCURRENT )**

*ENDPOL:*

{ This is the end of the polling routine. }

## Negative Input Voltage Protection

In most portable equipment, the DC power to charge batteries enters via a two-conductor cylindrical power jack. It is easy for the end user to add an adapter to switch the DC power's polarity. Polarized capacitor C6 would be destroyed if a negative voltage were applied. Diode D4 in Figure 3 prevents this from happening.

If reverse-polarity protection for the DC input power is not necessary, diode D4 can be omitted. This eliminates the power lost due to the voltage drop on diode D4.

## Selecting External Components for the MAX1647 4A Application

The MAX1647 can be configured to charge at a maximum current of 4A (instead of 2A, as shown in Figure 3) by changing the external power components and tying SEL to REF. The following paragraphs discuss the selection requirements for each component in Figure 3 that must be changed to accommodate the 4A application.

Diode D4 in Figure 3 has to support both the charge current and the current required to operate the host load (i.e., what the batteries normally power when not charging). This means that the continuous current flowing through D4 exceeds 4A. One possible choice for D4 is the Motorola MBRD835L 8A Schottky barrier diode in a DPAK surface-mount package. Care must be taken in thermal management of the circuit board when using the 4A application circuit, by mounting D4 on a three-square-inch piece of copper.

Motorola's MBRD835L can also be used for D3. The Siliconix Si4410DY is a good choice for M1 and M2 in the 4A application. Changing M2 from a 2N7002 (Table 1) to a Si4410DY increases the power dissipated by the MAX1647's 20-pin SSOP.

High-current inductors are difficult to find in surface-mount packages. Low-cost solutions use toroidal powdered-iron cores with exposed windings of heavy-gauge wire. The Coiltronics CTX20-5-52 20μH 5A inductor provides a high-efficiency solution.

R1A must also dissipate more power in the 4A application circuit than in the circuit of Figure 3. R1A's value decreases to 50mΩ in the 4A application. IRC's LR2512-01-R050-F meets this requirement with a 1W maximum power-dissipation rating.

# Chemistry-Independent Battery Chargers

MAX1647/MAX1648

**Table 7. ChargerStatus( ) Bit Descriptions**

NAME	BIT POSITION	LATCHED?	DESCRIPTION
CHARGE_INHIBITED	0	Yes	0 = Ready to charge a smart battery 1 = Charger is off; IOUT current = 0mA; DLO = PGND; DHI = LX
MASTER_MODE	1	N/A	Always returns '0'
VOLTAGE_NOTREG	2	No	0 = BATT voltage is limited at the voltage set point (BATT = V0). 1 = BATT voltage is less than the voltage set point (BATT < V0).
CURRENT_NOTREG	3	No	0 = Current through R1 is at its limit (IBATT = I0). 1 = Current through R1 is less than its limit (IBATT < I0).
LEVEL_2	4	N/A	Always returns 1
LEVEL_3	5	N/A	Always returns 0
CURRENT_OR	6	No	0 = ChargingCurrent( ) value is valid for MAX1647. 1 = ChargingCurrent( ) value exceeds what MAX1647 can actually deliver.
VOLTAGE_OR	7	No	0 = ChargingVoltage( ) value is valid for MAX1647. 1 = ChargingVoltage( ) value exceeds what MAX1647 can actually deliver.
THERMISTOR_OR	8	No	0 = THM voltage < 91% of REF voltage 1 = THM voltage > 91% of REF voltage
THERMISTOR_COLD	9	No	0 = THM voltage < 75% of REF voltage 1 = THM voltage > 75% of REF voltage
THERMISTOR_HOT	10	Yes	This bit reports the state of an internal SR flip-flop (denoted THERMISTOR_HOT flip-flop). The THERMISTOR_HOT flip-flop is set whenever THM is below 23% of REF. It is cleared whenever BATTERY_PRESENT = 0 or ChargerMode( ) is written with POR_RESET = 1.
THERMISTOR_UR	11	No	0 = THM voltage > 5% of REF voltage 1 = THM voltage < 5% of REF voltage
ALARM_INHIBITED	12	Yes	This bit reports the state of an internal SR flip-flop (denoted ALARM_INHIBITED flip-flop). The ALARM_INHIBITED flip-flop is set whenever the AlarmWarning( ) command is written with D15, D14, or D12 set. The ALARM_INHIBITED flip-flop is cleared whenever BATTERY_PRESENT = 0 or ChargerMode( ) is written with POR_RESET = 1.
POWER_FAIL	13	No	0 = BATT voltage < 89% of DCIN voltage 1 = BATT voltage > 89% of DCIN voltage
BATTERY_PRESENT	14	No	0 = No battery is present (THERMISTOR_OR = 1). 1 = A battery is present (THERMISTOR_OR = 0).
AC_PRESENT	15	No	0 = VL voltage < 4V 1 = VL voltage > 4V

\*Bit position in the D15-D0 data.

N/A = Not applicable.

## Chip Information

TRANSISTOR COUNT: 3612

SUBSTRATE CONNECTED TO AGND

# Chemistry-Independent Battery Chargers

## Package Information

(The package drawing(s) in this data sheet may not reflect the most current specifications. For the latest package outline information, go to [www.maxim-ic.com/packages](http://www.maxim-ic.com/packages).)

DIM	INCHES		MILLIMETERS	
	MIN	MAX	MIN	MAX
A	0.068	0.078	1.73	1.99
A1	0.002	0.008	0.05	0.21
B	0.010	0.015	0.25	0.38
C	0.004	0.008	0.09	0.20
D	SEE VARIATIONS			
E	0.205	0.212	5.20	5.38
e	0.0256 BSC		0.65 BSC	
H	0.301	0.311	7.65	7.90
L	0.025	0.037	0.63	0.95
$\alpha$	0 $^\infty$	8 $^\infty$	0 $^\infty$	8 $^\infty$

D	INCHES		MILLIMETERS		N
	MIN	MAX	MIN	MAX	
D	0.239	0.249	6.07	6.33	14L
D	0.239	0.249	6.07	6.33	16L
D	0.278	0.289	7.07	7.33	20L
D	0.317	0.328	8.07	8.33	24L
D	0.397	0.407	10.07	10.33	28L

NOTES:

1. D&E DO NOT INCLUDE MOLD FLASH.
2. MOLD FLASH OR PROTRUSIONS NOT TO EXCEED .15 MM (.006").
3. CONTROLLING DIMENSION: MILLIMETERS.
4. MEETS JEDEC MO150.
5. LEADS TO BE COPLANAR WITHIN 0.10 MM.

<small>PROPRIETARY INFORMATION</small>	
<small>TITLE:</small> PACKAGE OUTLINE, SSOP, 5.3 MM	
<small>APPROVAL</small>	<small>DOCUMENT CONTROL NO.</small> 21-0056
<small>REV.</small> C	<small>1/1</small>

SSOP.EPS

# Chemistry-Independent Battery Chargers

## Package Information (continued)

(The package drawing(s) in this data sheet may not reflect the most current specifications. For the latest package outline information, go to [www.maxim-ic.com/packages](http://www.maxim-ic.com/packages).)

MAX1647/MAX1648

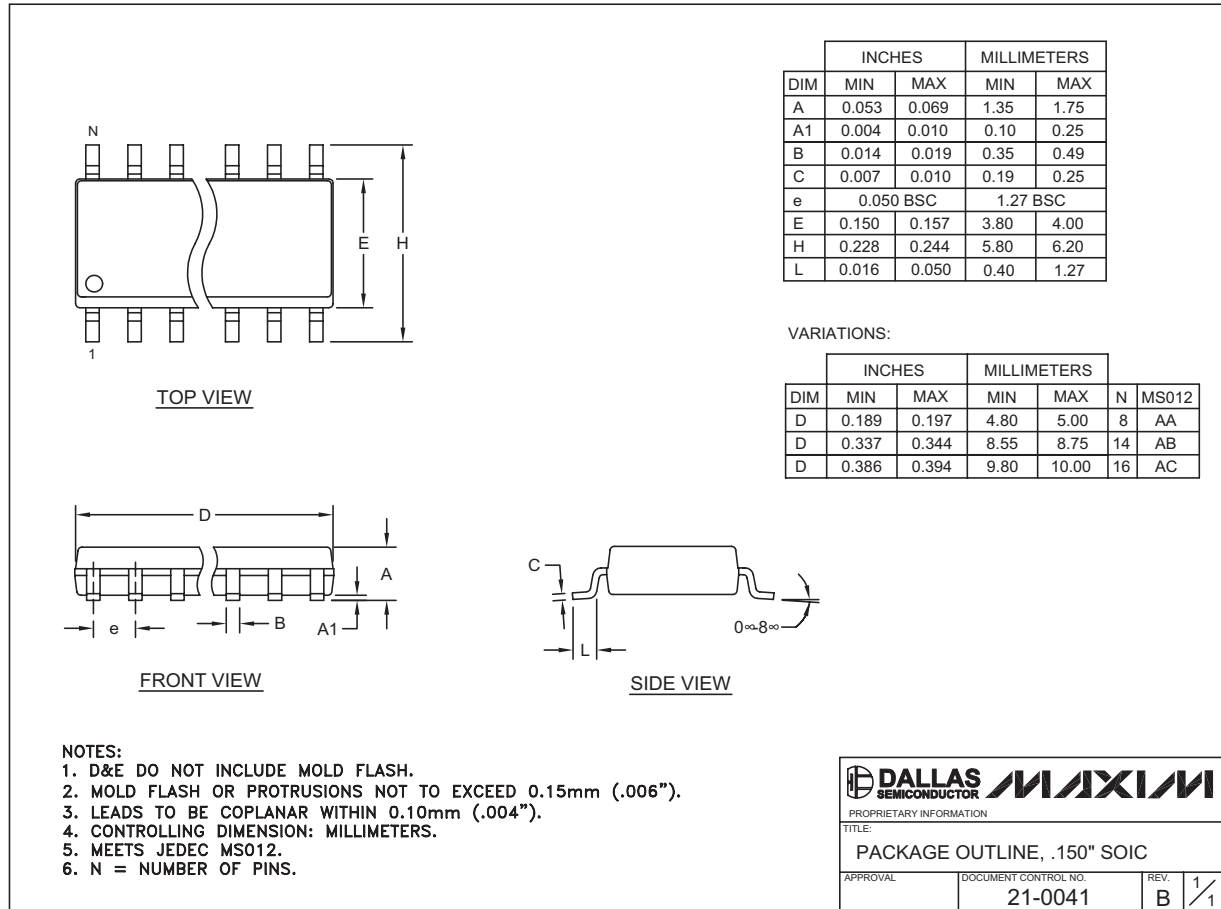

Maxim cannot assume responsibility for use of any circuitry other than circuitry entirely embodied in a Maxim product. No circuit patent licenses are implied. Maxim reserves the right to change the circuitry and specifications without notice at any time.

Maxim Integrated Products, 120 San Gabriel Drive, Sunnyvale, CA 94086 408-737-7600 \_\_\_\_\_ 25

## Looking for pricing, stock, or lifecycle information?

Click below to explore more details on WIN SOURCE:

- ⊖ [View MAX1647EAP](#) on WIN SOURCE
- ⊖ [Maxim Integrated](#) Information

## Optimize Your Supply Chain with WIN SOURCE Solutions

- ✓ Global Sourcing Solution
- ✓ Obsolete Management
- ✓ Cost Control Management
- ✓ Shortage Management
- ✓ Alternative Solution
- ✓ Excess Inventory Management