



**THE DATASHEET OF
MAX1576ETG+**



480mA White LED 1x/1.5x/2x Charge Pump for Backlighting and Camera Flash

General Description

The MAX1576 charge pump drives up to 8 white LEDs with regulated constant current for uniform intensity. The main group of LEDs (LED1–LED4) can be driven up to 30mA per LED for backlighting. The flash group of LEDs (LED5–LED8) are independently controlled and can be driven up to 100mA per LED (or 400mA total). By utilizing adaptive 1x/1.5x/2x charge-pump modes and very-low-dropout current regulators, the MAX1576 achieves high efficiency over the full 1-cell lithium-battery voltage range. The 1MHz fixed-frequency switching allows for tiny external components, and the regulation scheme is optimized to ensure low EMI and low input ripple.

The MAX1576 uses two external resistors to set the main and flash full-scale (100%) LED currents. Four control pins are used for LED dimming by either serial control or 2-bit logic per group. ENM1 and ENM2 set the main LEDs to 10%, 30%, or 100% of full scale. ENF1 and ENF2 set the flash LEDs to 20%, 40%, or 100% of full scale. In addition, connect either pair of control pins together for single-wire, serial pulse dimming control.

The MAX1576 is available in a 24-pin thin QFN, 4mm x 4mm package (0.8mm max height).

Applications

Camera Phones
LCD Backlights
LED Camera Flashes
Cell Phones and Smart Phones
PDAs, Digital Cameras, and Camcorders

Features

- ◆ Powers Up to 8 LEDs
 - Up to 30mA/LED Drive for Backlight
 - Up to 400mA Total Drive for Flash
- ◆ 85% Average Efficiency (PLED / PBATT) Over Li+ Battery Discharge
- ◆ 0.7% Typical LED Current Matching
- ◆ Adaptive 1x/1.5x/2x Mode Switchover
- ◆ Flexible Brightness Control
 - Single-Wire, Serial Pulse Interface (5% to 100%)
 - 2-Bit (3 Levels) Logarithmic Logic
- ◆ Low Input Ripple and EMI
- ◆ Low 0.1µA Shutdown Current
- ◆ 2.7V to 5.5V Supply Voltage Range
- ◆ Soft-Start Limits Inrush Current
- ◆ Output Overvoltage Protection
- ◆ Thermal-Shutdown Protection
- ◆ 24-Pin Thin QFN, 4mm x 4mm Package

Ordering Information

PART	TEMP RANGE	PIN-PACKAGE
MAX1576ETG	-40°C to +85°C	24 Thin QFN 4mm x 4mm (T2444-4)
MAX1576ETG+	-40°C to +85°C	24 Thin QFN 4mm x 4mm (T2444-4)

+ Denotes lead-free package.

Pin Configuration appears at end of data sheet.

Typical Operating Circuit

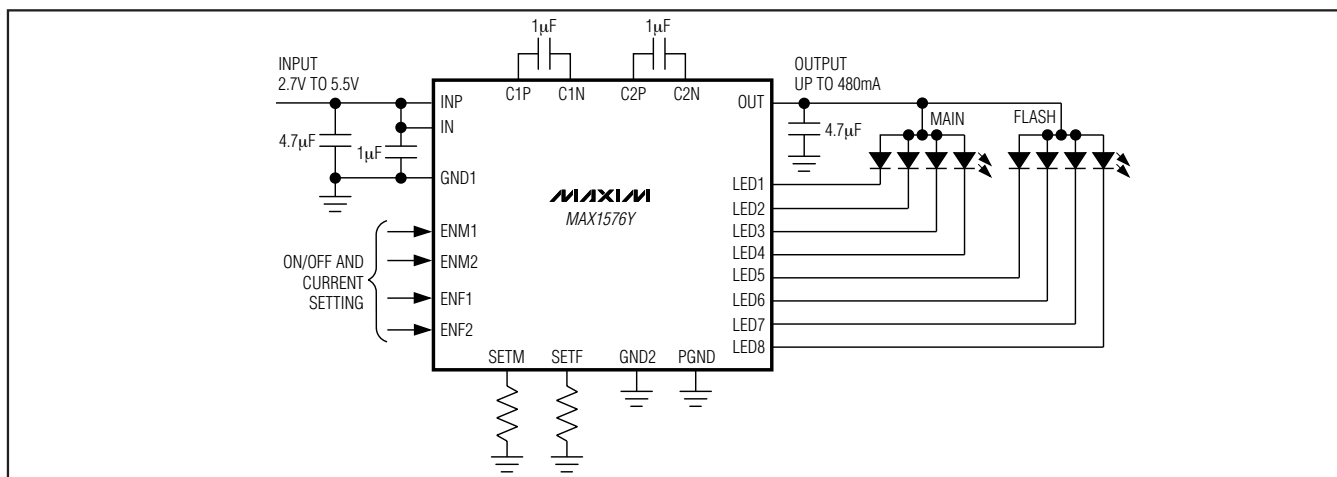

480mA White LED 1x/1.5x/2x Charge Pump for Backlighting and Camera Flash

ABSOLUTE MAXIMUM RATINGS

INP, IN, OUT, ENM1, ENM2, ENF1,
 ENF2 to GND1-0.3V to +6.0V
 SETF, SETM, LED1, LED2, LED3, LED4, LED5,
 LED6, LED7, LED8 to GND1-0.3V to (V_{IN} + 0.3V)
 C1N, C2N to GND1-0.3V to (V_{IN} + 1V)
 C1P, C2P to
 GND1 -0.3V to Greater of (V_{OUT} + 1V) or (V_{IN} + 1V)
 GND2, PGND to GND1-0.3V to +0.3V

OUT Short Circuit to GNDContinuous
 Continuous Power Dissipation (T_A = +70°C)
 24-Pin Thin QFN (derate 20.8mW/°C)
 above +70°C).....1666mW
 Operating Temperature Range-40°C to +85°C
 Junction Temperature+150°C
 Storage Temperature Range-65°C to +150°C
 Lead Temperature (soldering, 10s).....+300°C

Stresses beyond those listed under "Absolute Maximum Ratings" may cause permanent damage to the device. These are stress ratings only, and functional operation of the device at these or any other conditions beyond those indicated in the operational sections of the specifications is not implied. Exposure to absolute maximum rating conditions for extended periods may affect device reliability.

ELECTRICAL CHARACTERISTICS

(V_{IN} = 3.6V, V_{GND1} = V_{GND2} = V_{PGND} = 0V, ENM1 = ENM2 = ENF1 = ENF2 = IN, R_{SETM} = R_{SETF} = 6.8kΩ, T_A = -40°C to +85°C, unless otherwise noted. Typical values are at T_A = +25°C.) (Note 1)

PARAMETER	CONDITIONS	MIN	TYP	MAX	UNITS
IN Operating Voltage		2.7		5.5	V
Undervoltage-Lockout Threshold	V _{IN} rising or falling	2.25	2.45	2.60	V
Undervoltage-Lockout Hysteresis			50		mV
Oversvoltage Protection Threshold	V _{OUT} rising		5		V
Supply Current	1MHz switching, no load, 1.5x or 2x mode 1x mode 10% setting, LED5–LED8 off		3.8 0.3	6.0	mA
Shutdown Supply Current	ENM1 = ENM2 = ENF1 = ENF2 = GND		0.1	3	μA
Soft-Start Time			2		ms
SET_ Bias Voltage			0.604		V
SET_ Leakage in Shutdown	ENM1 = ENM2 = ENF1 = ENF2 = GND, V _{SET_} = 0V or V _{IN}		0.01	1	μA
SETM Current Range		40		130	μA
SETF Current Range		40		145	μA
SETM to Main LED_ Current Ratio (I _{LED} / I _{SETM})	100% setting, LED1–4		233		A/A
SETF to Flash LED_ Current Ratio (I _{LED} / I _{SETF})	100% setting, LED5–8		708		A/A
LED_ Current Accuracy	LED1–4 LED5–8	-6 -8		+6 +8	%
LED_ to LED_ Current Matching	(Note 2)	-3.5	±0.7	+3.5	%
Maximum LED_ Sink Current	LED1–LED4, R _{SETM} = 4.64kΩ LED5–LED8, R _{SETF} = 4.12kΩ	27 90	30 100		mA
LED_ Dropout Voltage	(Note 3)		40	90	mV
LED_ 1.5x and 2x Regulation Voltage			150		mV
LED_ 1x to 1.5x or 1.5x to 2x Mode Transition Threshold		90	100	110	mV
Input-Voltage-Mode Transition Hysteresis			150		mV

480mA White LED 1x/1.5x/2x Charge Pump for Backlighting and Camera Flash

MAX1576

ELECTRICAL CHARACTERISTICS (continued)

($V_{IN} = 3.6V$, $V_{GND1} = V_{GND2} = V_{PGND} = 0V$, $ENM1 = ENM2 = ENF1 = ENF2 = IN$, $R_{SETM} = R_{SETF} = 6.8k\Omega$, $T_A = -40^{\circ}C$ to $+85^{\circ}C$, unless otherwise noted. Typical values are at $T_A = +25^{\circ}C$.) (Note 1)

PARAMETER	CONDITIONS	MIN	TYP	MAX	UNITS
LED_ Leakage in Shutdown	$ENM1 = ENM2 = ENF1 = ENF2 = GND$		0.1	2	μA
Charge-Pump Maximum OUT Current	$V_{IN} \geq 3.15V$, $V_{OUT} = 3.9V$	480			mA
Open-Loop OUT Resistance	1x mode, $(V_{IN} - V_{OUT}) / I_{OUT}$			2.5	Ω
	1.5x mode, $(1.5V_{IN} - V_{OUT}) / I_{OUT}$			5.0	
	2x mode, $(2V_{IN} - V_{OUT}) / I_{OUT}$			5.0	
Switching Frequency			1		MHz
EN_ High Voltage	$V_{IN} = 2.7V$ to $5.5V$	1.6			V
EN_ Low Voltage	$V_{IN} = 2.7V$ to $5.5V$			0.4	V
EN_ Input Current	$V_{EN_} = 0V$ or $5.5V$		0.01	1	μA
EN_ Low Shutdown Delay t_{SHDN} (See Figure 3)		225	470	800	μs
EN_ t_{LO} (See Figure 3)		0.5		250.0	μs
EN_ t_{HI} (See Figure 3)		0.5			μs
Initial EN_ t_{HI} (See Figure 3)	Only required for first EN_ pulse	50			μs
OUT Pulldown Resistance in Shutdown	$ENM1 = ENM2 = ENF1 = ENF2 = GND$		5		$k\Omega$
Thermal-Shutdown Threshold			+160		$^{\circ}C$
Thermal-Shutdown Hysteresis			20		$^{\circ}C$

Note 1: Specifications to $-40^{\circ}C$ are guaranteed by design and not production tested.

Note 2: LED current matching is defined as: $(I_{LED_} - I_{AVG}) / I_{AVG}$. Matching is for LEDs within the main group (LED1–LED4) or the flash group (LED5–LED8).

Note 3: Dropout voltage is defined as the LED_ to GND_ voltage at which current into LED_ drops 10% from the value at $V_{LED_} = 0.2V$.

480mA White LED 1x/1.5x/2x Charge Pump for Backlighting and Camera Flash

Typical Operating Characteristics

($V_{IN} = 3.6V$, $EN_{-} = IN$, Circuit of Figure 1, $R_{SETM} = 9.09k\Omega$, $R_{SETF} = 4.12k\Omega$, $T_A = +25^{\circ}C$, unless otherwise noted.)

EFFICIENCY vs. Li+ BATTERY VOLTAGE DRIVING FOUR MAIN LEDs

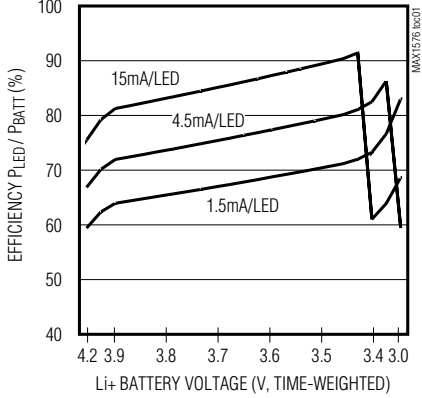

EFFICIENCY vs. Li+ BATTERY VOLTAGE DRIVING FLASH LED MODULE

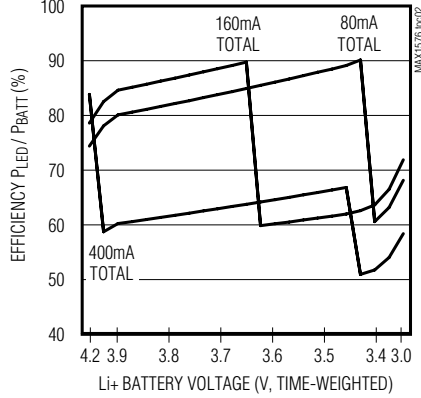

BATTERY CURRENT vs. SUPPLY VOLTAGE DRIVING FOUR MAIN LEDs

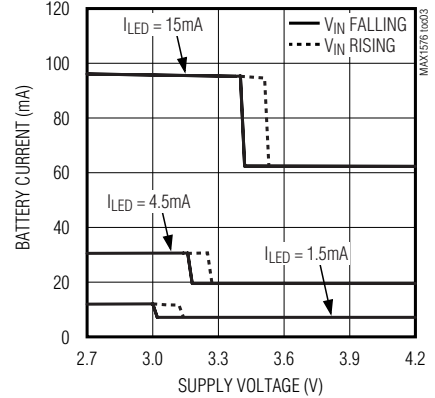

BATTERY CURRENT vs. SUPPLY VOLTAGE DRIVING FLASH

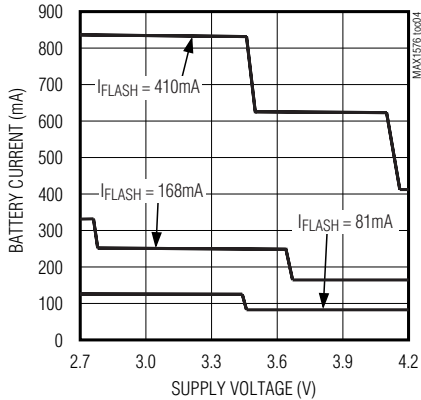

INPUT RIPPLE VOLTAGE vs. SUPPLY VOLTAGE WITH FOUR MAIN LEDs

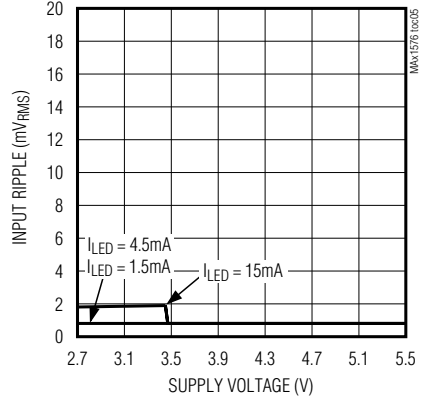

INPUT RIPPLE VOLTAGE vs. SUPPLY VOLTAGE WITH FLASH AND MAIN LEDs

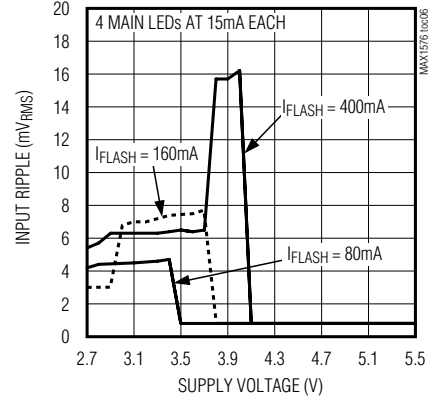

LED CURRENT MATCHING vs. SUPPLY VOLTAGE WITH FOUR MAIN LEDs

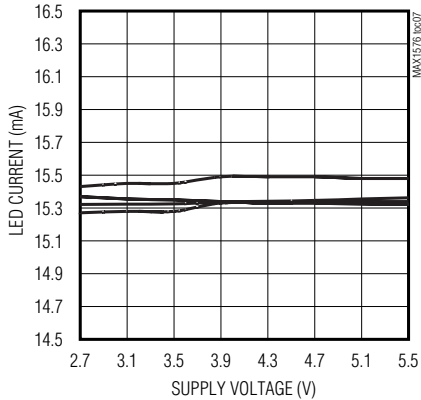

LED CURRENT vs. AMBIENT TEMPERATURE WITH FOUR MAIN LEDs

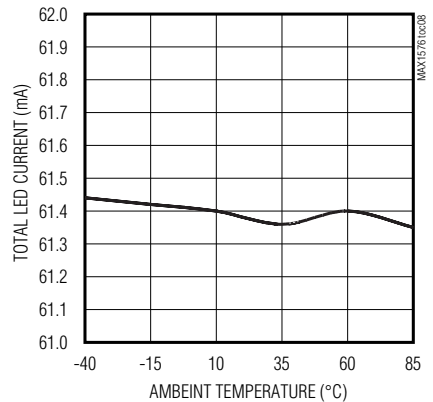

LED CURRENT vs. AMBIENT TEMPERATURE WITH FLASH

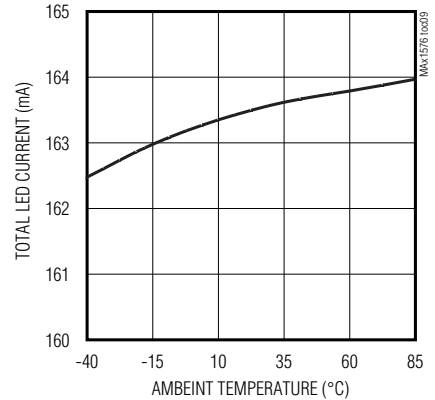

480mA White LED 1x/1.5x/2x Charge Pump for Backlighting and Camera Flash

MAX1576

Typical Operating Characteristics (continued)

($V_{IN} = 3.6V$, $EN_{-} = IN$, Circuit of Figure 1, $R_{SETM} = 9.09k\Omega$, $R_{SETF} = 4.12k\Omega$, $T_A = +25^{\circ}C$, unless otherwise noted.)

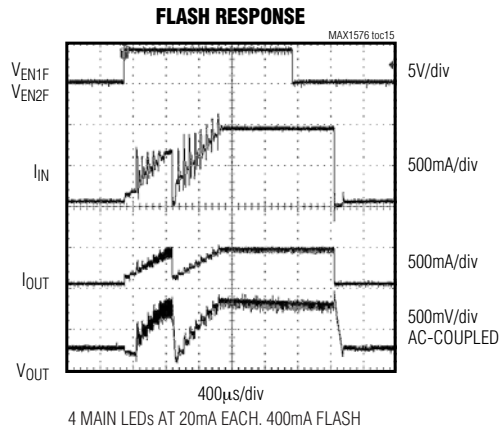
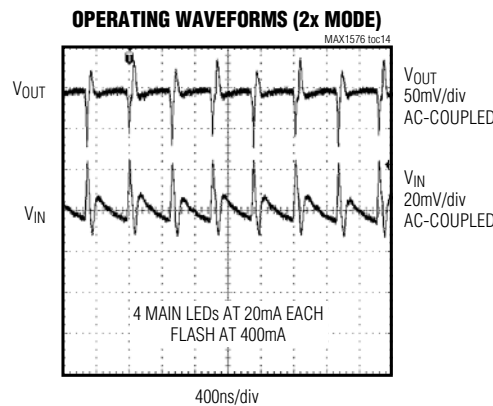
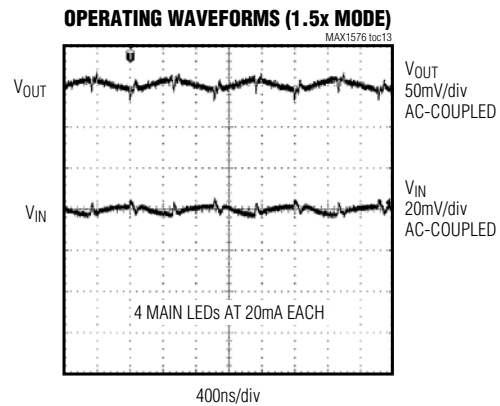
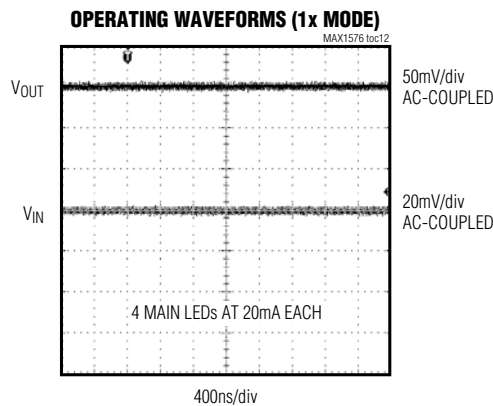
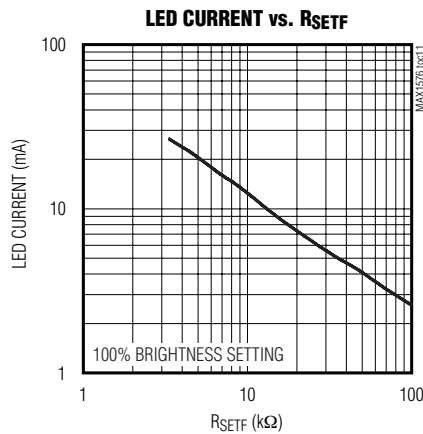
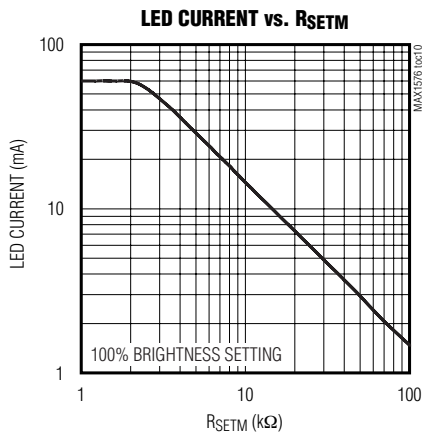

480mA White LED 1x/1.5x/2x Charge Pump for Backlighting and Camera Flash

Typical Operating Characteristics (continued)

($V_{IN} = 3.6V$, $EN_ = IN$, Circuit of Figure 1, $R_{SETM} = 9.09k\Omega$, $R_{SETF} = 4.12k\Omega$, $T_A = +25^\circ C$, unless otherwise noted.)

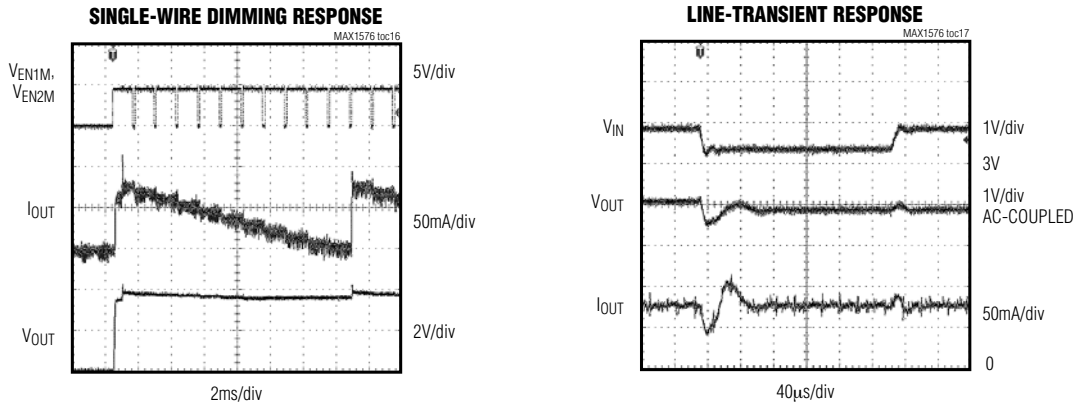

Pin Description

PIN	NAME	FUNCTION
1	OUT	Output. Bypass to ground with a 4.7µF ceramic capacitor. Connect to the anodes of all the LEDs. OUT is internally pulled to ground through a 5kΩ resistor during shutdown.
2	ENM1	Enable and Brightness Control for LED1–LED4 (Backlight). See Table 1 and Figure 3.
3	ENM2	
4	ENF1	Enable and Brightness Control for LED5–LED8 (Flash). See Table 2 and Figure 3.
5	ENF2	
6	LED8	Flash LED_ Cathode Connection and Charge-Pump Feedback. Current flowing into LED_ is based on the ENF_ logic levels and R _{SETF} . The charge pump regulates the lowest LED_ voltage to 0.15V. Grounding any LED_ forces OUT to operate at approximately 5V. Connect LED_ to IN if this LED is not populated.
7	LED7	
9	LED6	
10	LED5	
8	GND2	
14	GND1	
11	LED4	Main LED_ Cathode Connection and Charge-Pump Feedback. Current flowing into LED_ is based on the ENM_ logic levels and R _{SETM} . The charge-pump regulates the lowest LED_ voltage to 0.15V. Grounding any LED_ forces OUT to operate at approximately 5V. Connect LED_ to IN if this LED is not populated.
12	LED3	
13	LED2	
15	LED1	
16	SETM	
17	SETF	Bias Current Set Input for LED5–LED8. The current flowing out of SETF sets the maximum (100%) bias current into each LED. SETF is internally biased to 0.604V. Connect a resistor (R _{SETF}) from SETF to ground to set the flash LED current, $R_{SETF} = (708 \times 0.604) / I_{LED(MAX)}$. SETF is high impedance during shutdown.

480mA White LED 1x/1.5x/2x Charge Pump for Backlighting and Camera Flash

MAX1576

Pin Description (continued)

PIN	NAME	FUNCTION
18	IN	Supply Voltage Input. Bypass to ground with a 1μF ceramic capacitor. The input voltage range is 2.7V to 5.5V. IN is high impedance during shutdown.
19	PGND	Power Ground. Connect PGND to system ground. PGND is used for charge-pump switching currents.
20	C1N	Transfer Capacitor 1 Negative Connection. Connect to a 1μF ceramic capacitor between C1P and C1N. C1N is internally shorted to IN during shutdown.
21	C2N	Transfer Capacitor 2 Negative Connection. Connect to a 1μF ceramic capacitor between C2P and C2N. C2N is internally shorted to IN during shutdown.
22	INP	Supply Voltage Input. Bypass to PGND with a 4.7μF ceramic capacitor. The input voltage range is 2.7V to 5.5V. INP is high impedance during shutdown.
23	C2P	Transfer Capacitor 2 Positive Connection. Connect a 1μF ceramic capacitor from C2P to C2N. During shutdown, if OUT > IN, C2P is shorted to OUT, and if OUT < IN, C2P is shorted to IN.
24	C1P	Transfer Capacitor 1 Positive Connection. Connect a 1μF ceramic capacitor from C1P to C1N. During shutdown, if OUT > IN, C1P is shorted to OUT, and if OUT < IN, C1P is shorted to IN.
—	EP	Exposed Paddle. Connect the exposed paddle to ground. Connect PGND, GND1, and GND2 to the exposed paddle directly under the IC.

Detailed Description

The MAX1576 charge pump drives up to four white LEDs in the main display for backlighting and up to four white LEDs for flash with regulated constant current for uniform intensity. By utilizing adaptive 1x/1.5x/2x charge-pump modes and very-low-dropout current regulators, it achieves high efficiency over the 1-cell lithium-battery input voltage range. 1MHz fixed-frequency switching allows for tiny external components and low input ripple.

1x to 1.5x Switchover

When V_{IN} is higher than V_{OUT} , the MAX1576 operates in 1x mode and V_{OUT} is pulled up to V_{IN} . The internal current regulators regulate the LED current. As V_{IN} drops, $V_{LED_}$ eventually falls below the switchover threshold of 100mV and the MAX1576 starts switching in 1.5x mode. When the input voltage rises above V_{OUT} by approximately 50mV, the MAX1576 switches back to 1x mode.

1.5x to 2x Switchover

When V_{IN} is less than V_{OUT} but greater than two-thirds V_{OUT} , the MAX1576 operates in 1.5x mode. The internal current regulators regulate the LED current. As V_{IN} drops, $V_{LED_}$ eventually falls below the switchover threshold of 100mV, and the MAX1576 starts switching in 2x mode. When the input voltage rises above two-thirds V_{OUT} by approximately 50mV, the MAX1576 switches back to 1.5x mode.

True Shutdown is a trademark of Maxim Integrated Products, Inc.

Soft-Start

The MAX1576 includes soft-start circuitry to limit inrush current at turn-on. Once the input voltage is applied, the output capacitor is charged directly from the input with a ramped current source (with no charge-pump action) until the output voltage approaches the input voltage. Once this occurs, the charge pump determines if 1x, 1.5x, or 2x mode is required. In the case of 1x mode, the soft-start is terminated and normal operation begins. In the case of 1.5x or 2x mode, soft-start operates until the lowest of LED1–LED4 reaches regulation. If the output is shorted to ground or is pulled less than 1.25V, the output current is limited by soft-start.

True Shutdown™ Mode

When ENM1, ENM2, ENF1, and ENF2 are simultaneously held low, the MAX1576 is shut down after a 0.5ms shutdown delay and the input is isolated from the output. OUT is internally pulled to GND with 5kΩ during shutdown.

Thermal Shutdown

The MAX1576 includes a thermal-limit circuit that shuts down the IC at approximately +160°C. Turn-on occurs after the IC cools by approximately 20°C.

Applications Information

Setting the Main Output Current

SETM controls LED1–LED4 bias current. Current flowing into LED1, LED2, LED3, and LED4 is a multiple of the current flowing out of SETM.

$$I_{LED1} = I_{LED2} = I_{LED3} = I_{LED4} = K \times (0.604V / R_{SETM})$$

480mA White LED 1x/1.5x/2x Charge Pump for Backlighting and Camera Flash

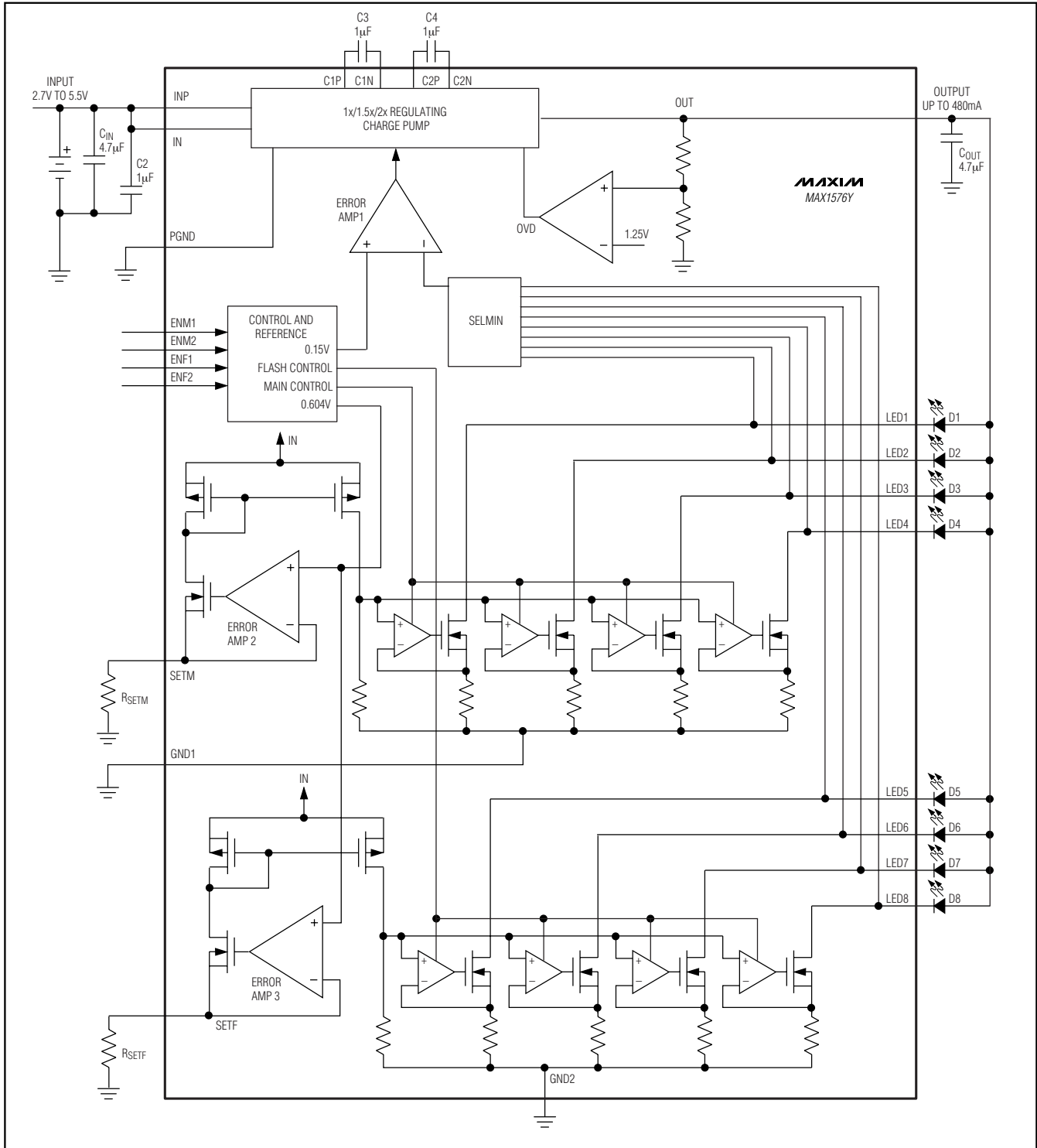

Figure 1. Block Diagram and Typical Application Circuit

480mA White LED 1x/1.5x/2x Charge Pump for Backlighting and Camera Flash

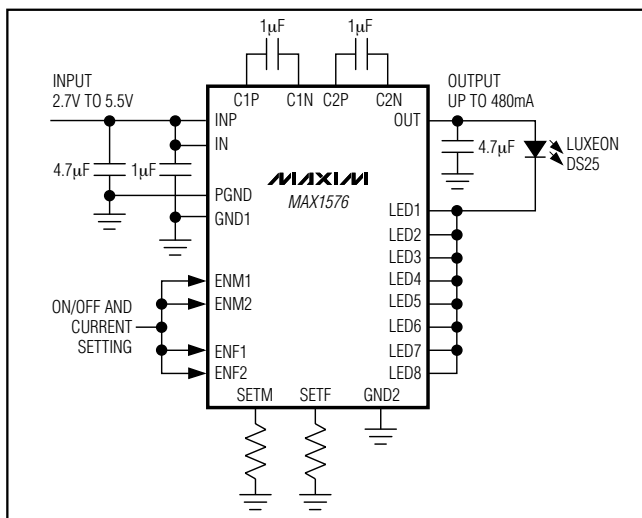

Figure 2. Typical Application Circuit for Driving a Single High-Brightness LED

Table 1. ENM1/ENM2 States

ENM1/ENM2 STATES	BRIGHTNESS	LED1–LED4 CURRENT
ENM1 = low, ENM2 = low	Shutdown	0
ENM1 = low, ENM2 = high	1/10 Brightness	23 x I _{SETM}
ENM1 = high, ENM2 = low	3/10 Brightness	70 x I _{SETM}
ENM1 = high, ENM2 = high	Full Brightness	233 x I _{SETM}

Table 2. ENF1/ENF2 States

ENF1/ENF2 STATES	BRIGHTNESS	LED5–LED8 CURRENT
ENF1 = low, ENF2 = low	Shutdown	0
ENF1 = low, ENF2 = high	1/5 Brightness	142 x I _{SETM}
ENF1 = high, ENF2 = low	2/5 Brightness	283 x I _{SETM}
ENF1 = high, ENF2 = high	Full Brightness	708 x I _{SETM}

where K = 23, 70, or 233 (depending upon the state of ENM1 and ENM2, see Table 1), and R_{SETM} is the resistor connected between SETM and ground (see the *Typical Operating Circuit*).

Setting the Flash Output Current

SETF controls the LED5–LED8 bias current. Current flowing into LED5, LED6, LED7, and LED8 is a multiple of the current flowing out of SETF.

$$I_{LED5} = I_{LED6} = I_{LED7} = I_{LED8} = N \times (0.604V / R_{SETF})$$

where N = 142, 283, or 708 (depending upon ENF1 and ENF2, see Table 2), and R_{SETF} is the resistor connected between SETF and ground (see the *Typical Operating Circuit*).

Single-Wire Pulse Dimming

For more dimming flexibility or to reduce the number of control traces, the MAX1576 supports serial pulse dimming. Connect ENM1 and ENM2 (or ENF1 and ENF2) together to enable single-wire pulse dimming of the main (or flash) LEDs. When ENM1 and ENM2 (or ENF1 and ENF2) go high simultaneously, the main (or flash) LEDs are enabled at full brightness. Each subsequent low-going pulse (500ns to 250µs pulse width) reduces the LED current by 10%, so after one pulse the LED current is 0.9 x I_{LED_}. The 10th pulse reduces the current by 5% so the LED current reduces from 0.1 x I_{LED_} to 0.05 x I_{LED_}. The 11th pulse sets the LED current back to I_{LED_}. Figure 3 shows a timing diagram for single-wire pulse dimming. Because soft-start is longer than the initial t_{HI}, apply dimming pulses quickly upon startup (after initial t_{HI}) to avoid LED_ current transitioning through full brightness.

Simple On/Off Control

If dimming control is not required, connect ENM1 to ENM2 (or ENF1 to ENF2) for simple on/off control. In this case, LED current is set by the values of R_{SETM} (or R_{SETF}).

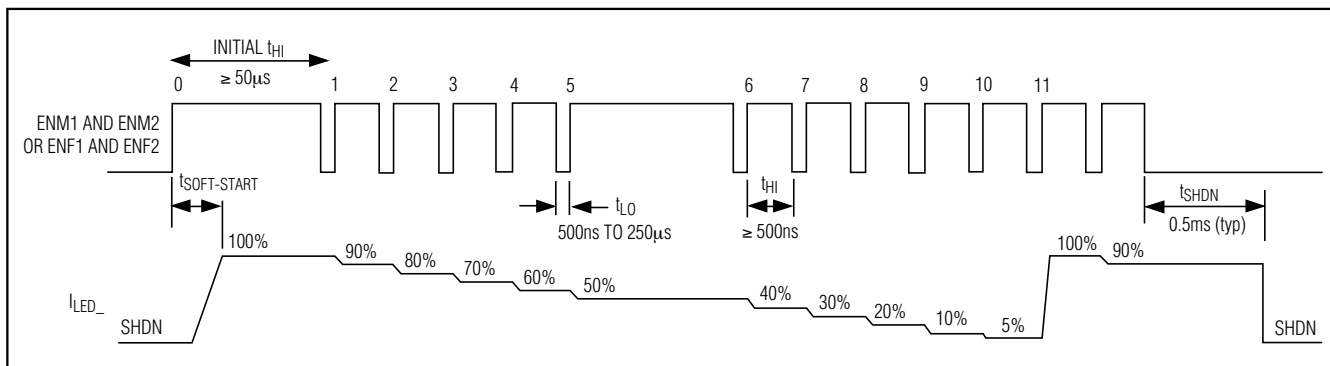

Figure 3. EN_ Timing Diagram

480mA White LED 1x/1.5x/2x Charge Pump for Backlighting and Camera Flash

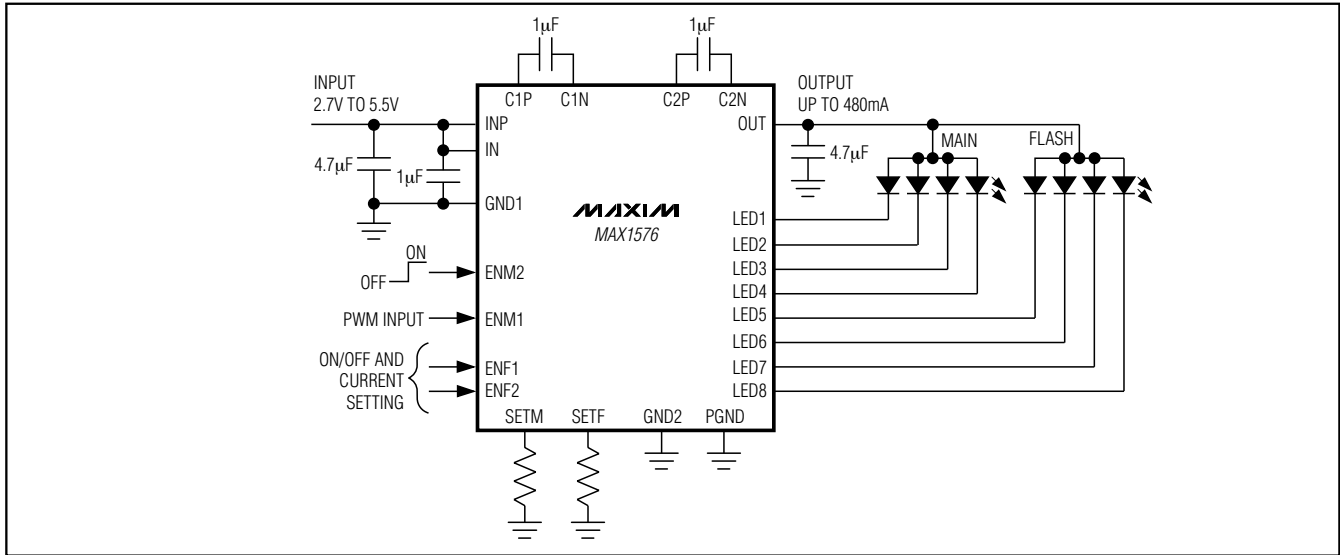

Figure 4. Dimming Using PWM Signal into ENM1

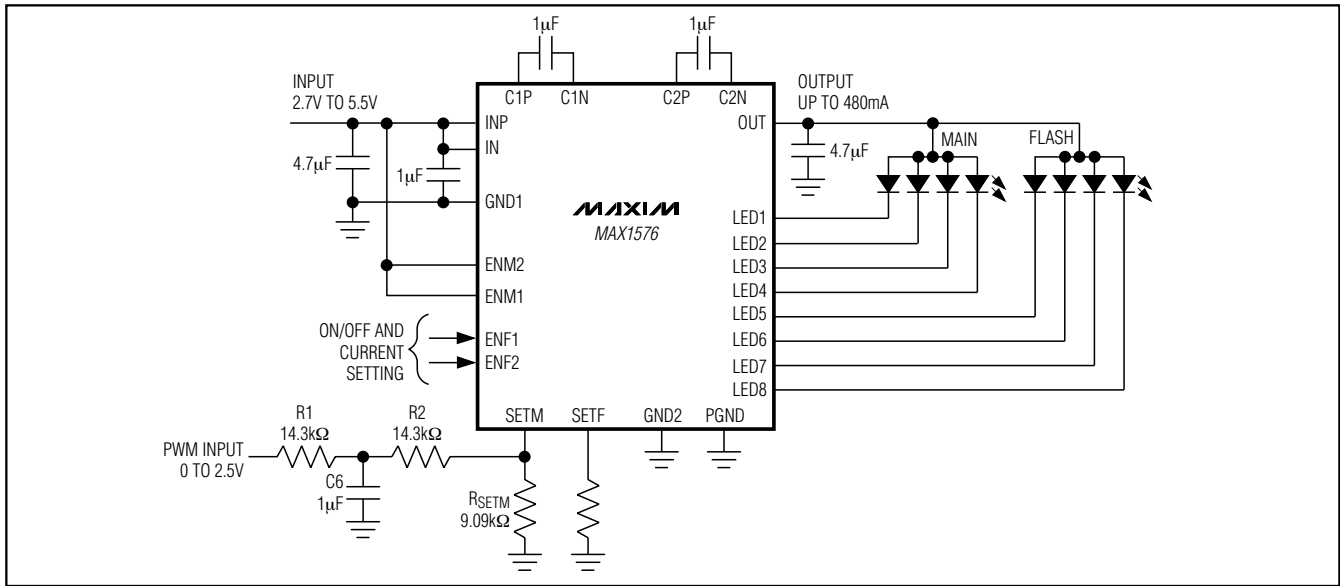

Figure 5. Dimming Using Filtered PWM Signal

Dimming Using PWM into ENM1

Use ENM2 for shutdown and drive ENM1 with a PWM signal. LED brightness can be varied from 1/10 to full brightness based on the duty cycle of the PWM signal. The waveforms in the *Typical Operating Characteristics* show the response time of dimming. Drive ENM2 high to keep the IC on, eliminating any soft-start delay that would impede PWM control and allowing a PWM frequency up to 5kHz (Figure 4).

Dimming Using a DAC or Filtered PWM

Both the main LEDs and flash LEDs allow dimming using a DAC or filtered PWM. Use a DAC output to sum a current into the SET₋ node, or use a high-frequency PWM signal to drive an RCR filter on SET₋ (Figure 5). With the component values shown in Figure 5, a 0% PWM duty cycle corresponds to 20mA/LED, while a 100% PWM duty cycle corresponds to 0mA/LED. At PWM frequencies above 5kHz, C6 may be reduced.

480mA White LED 1x/1.5x/2x Charge Pump for Backlighting and Camera Flash

MAX1576

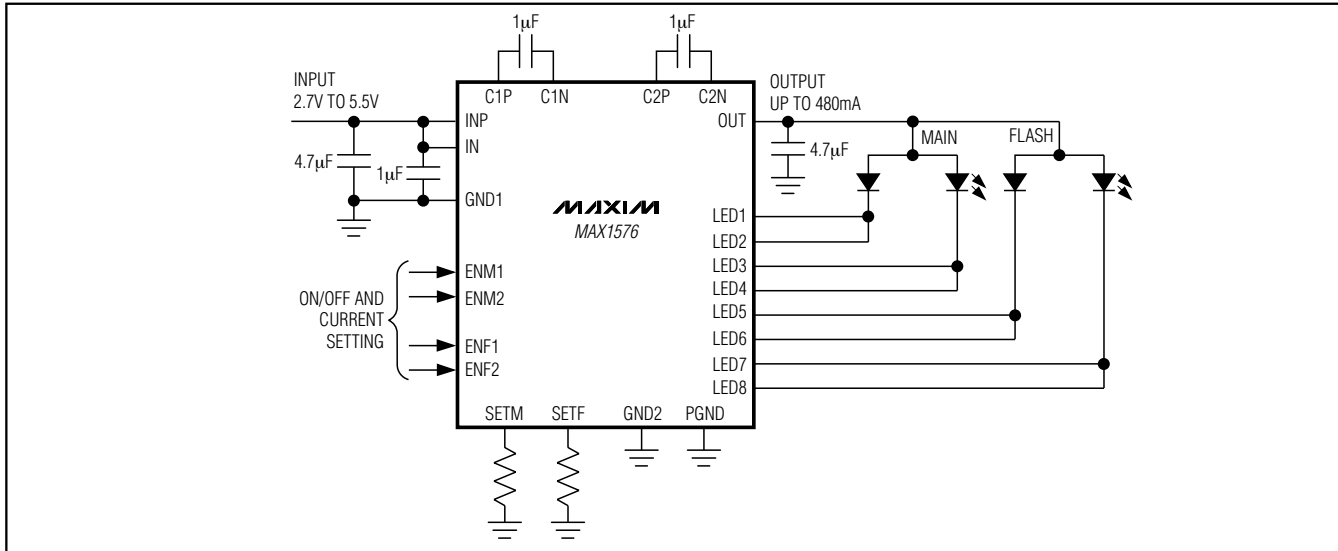

Figure 6. Providing Increased LED Current per LED

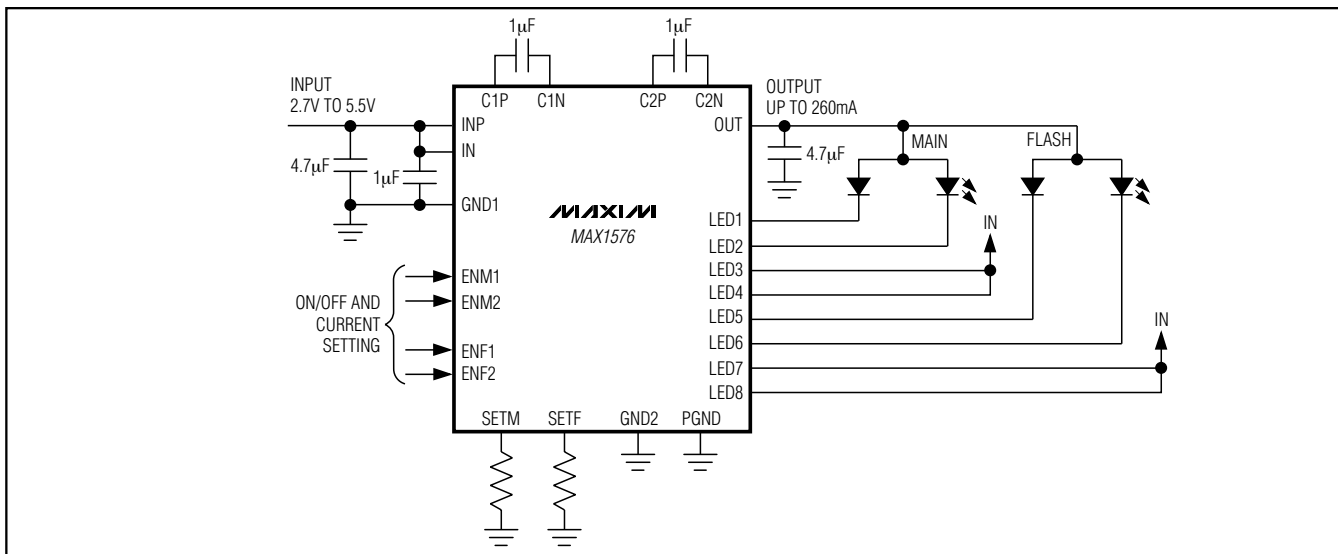

Figure 7. Schematic for when Fewer than 8 LEDs is Acceptable

Driving Fewer than 8 LEDs

When driving fewer than 8 LEDs, two different connection schemes can be used. The first scheme is shown in Figures 2 and 6, where LED_n is connected to the adjacent LED_{n-1}. This method allows increased current through the LED and effectively allows total LED current to be I_{LED} multiplied by the number of pins connected. The second method of connection is shown in Figure 7, where standard white LEDs are used and fewer than 8 are connected. This scheme does not alter current

through each LED but ensures that the unused LED_n is properly terminated.

Input Ripple

For LED drivers, input ripple is more important than output ripple. Input ripple is highly dependent on the source supply's impedance. Adding a lowpass filter to the input further reduces input ripple. Alternately, increasing C_{IN} to 10µF cuts input ripple in half with only a small increase in footprint. The 1x mode always has very low input ripple.

480mA White LED 1x/1.5x/2x Charge Pump for Backlighting and Camera Flash

Table 3. Recommended Components

DESIGNATION	VALUE	MANUFACTURER	PART NUMBER	DESCRIPTION
C _{IN} , C _{OUT}	4.7 μ F	Murata	GRM188R60J475K	4.7 μ F \pm 10%, 6.3V X5R ceramic capacitors (0603)
C ₂ , C ₃ , C ₄	1 μ F	Murata	GRM155R60J105K	1 μ F \pm 10%, 6.3V X5R ceramic capacitors (0402)
D1–D4	—	Nichia	NSCW215T	White LEDs
D5 (D5–D8)	—	Nichia	NBCW011T	White LEDs, four LEDs in one package
R _{SETM} , R _{SETF}	As required	Kamaya	—	1% resistors

Typical operating waveforms shown in the *Typical Operating Characteristics* show input ripple in 1x, 1.5x, and 2x mode.

Component Selection

Use only ceramic capacitors with an X5R, X7R, or better dielectric. See Table 3 for a list of recommended parts.

PC Board Layout and Routing

The MAX1576 is a high-frequency switched-capacitor voltage regulator. For best circuit performance, use a solid ground plane and place C_{IN}, C_{OUT}, C₂, C₃, and C₄ as close to the MAX1576 as possible. There should be no vias on C_{IN}. Connect GND1, GND2, and PGND to the exposed paddle directly under the IC. Refer to the MAX1576 evaluation kit for an example.

Chip Information

TRANSISTOR COUNT: 6679

PROCESS: BiCMOS

Pin Configuration

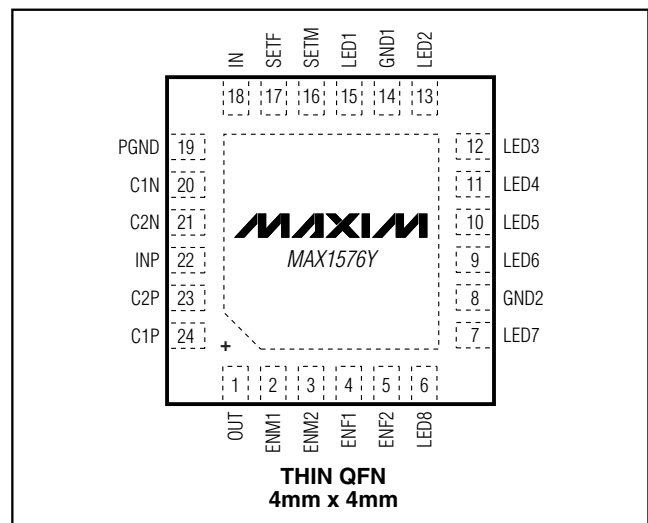

480mA White LED 1x/1.5x/2x Charge Pump for Backlighting and Camera Flash

Package Information (continued)

(The package drawing(s) in this data sheet may not reflect the most current specifications. For the latest package outline information, go to www.maxim-ic.com/packages.)

COMMON DIMENSIONS															
PKG	12L 4x4			16L 4x4			20L 4x4			24L 4x4			28L 4x4		
REF.	MIN.	NDM.	MAX.	MIN.	NDM.	MAX.	MIN.	NDM.	MAX.	MIN.	NDM.	MAX.	MIN.	NDM.	MAX.
A	0.70	0.75	0.80	0.70	0.75	0.80	0.70	0.75	0.80	0.70	0.75	0.80	0.70	0.75	0.80
A1	0.0	0.02	0.05	0.0	0.02	0.05	0.0	0.02	0.05	0.0	0.02	0.05	0.0	0.02	0.05
A2	0.20 REF			0.20 REF			0.20 REF			0.20 REF			0.20 REF		
b	0.25	0.30	0.35	0.25	0.30	0.35	0.20	0.25	0.30	0.18	0.23	0.30	0.15	0.20	0.25
D	3.90	4.00	4.10	3.90	4.00	4.10	3.90	4.00	4.10	3.90	4.00	4.10	3.90	4.00	4.10
E	3.90	4.00	4.10	3.90	4.00	4.10	3.90	4.00	4.10	3.90	4.00	4.10	3.90	4.00	4.10
e	0.80 BSC.			0.65 BSC.			0.50 BSC.			0.50 BSC.			0.40 BSC.		
k	0.25	-	-	0.25	-	-	0.25	-	-	0.25	-	-	0.25	-	-
L	0.45	0.55	0.65	0.45	0.55	0.65	0.45	0.55	0.65	0.30	0.40	0.50	0.30	0.40	0.50
N	12			16			20			24			28		
ND	3			4			5			6			7		
NE	3			4			5			6			7		
JeDEC Ver.	VGGB			VGGC			WGGD-1			WGGD-2			VGGE		

EXPOSED PAD VARIATIONS							
PKG. CODES	D2			E2			DOWN BONDS ALLOWED
	MIN.	NDM.	MAX.	MIN.	NDM.	MAX.	
T1244-3	1.95	2.10	2.25	1.95	2.10	2.25	YES
T1244-4	1.95	2.10	2.25	1.95	2.10	2.25	NO
T1644-3	1.95	2.10	2.25	1.95	2.10	2.25	YES
T1644-4	1.95	2.10	2.25	1.95	2.10	2.25	NO
T2044-2	1.95	2.10	2.25	1.95	2.10	2.25	YES
T2044-3	1.95	2.10	2.25	1.95	2.10	2.25	NO
T2444-2	1.95	2.10	2.25	1.95	2.10	2.25	YES
T2444-3	2.45	2.60	2.63	2.45	2.60	2.63	YES
T2444-4	2.45	2.60	2.63	2.45	2.60	2.63	NO
T2844-1	2.50	2.60	2.70	2.50	2.60	2.70	NO

NOTES:

- DIMENSIONING & TOLERANCING CONFORM TO ASME Y14.5M-1994.
 - ALL DIMENSIONS ARE IN MILLIMETERS. ANGLES ARE IN DEGREES.
 - N IS THE TOTAL NUMBER OF TERMINALS.
- ⚠ THE TERMINAL #1 IDENTIFIER AND TERMINAL NUMBERING CONVENTION SHALL CONFORM TO JEDEC 95-1 SPP-012. DETAILS OF TERMINAL #1 IDENTIFIER ARE OPTIONAL, BUT MUST BE LOCATED WITHIN THE ZONE INDICATED. THE TERMINAL #1 IDENTIFIER MAY BE EITHER A MOLD OR MARKED FEATURE.
- ⚠ DIMENSION b APPLIES TO METALLIZED TERMINAL AND IS MEASURED BETWEEN 0.25 mm AND 0.30 mm FROM TERMINAL TIP.
- ⚠ ND AND NE REFER TO THE NUMBER OF TERMINALS ON EACH D AND E SIDE RESPECTIVELY.
- DEPOPULATION IS POSSIBLE IN A SYMMETRICAL FASHION.
 - COPLANARITY APPLIES TO THE EXPOSED HEAT SINK SLUG AS WELL AS THE TERMINALS.
 - DRAWING CONFORMS TO JEDEC MO220, EXCEPT FOR T2444-3, T2444-4 AND T2844-1.
- ⚠ MARKING IS FOR PACKAGE ORIENTATION REFERENCE ONLY.
- COPLANARITY SHALL NOT EXCEED 0.08mm
 - WARPAGE SHALL NOT EXCEED 0.10mm
 - LEAD CENTERLINES TO BE AT TRUE POSITION AS DEFINED BY BASIC DIMENSION "e", ±0.05.
 - NUMBER OF LEADS SHOWN ARE FOR REFERENCE ONLY

-DRAWING NOT TO SCALE-

TITLE PACKAGE OUTLINE, 12, 16, 20, 24, 28L THIN QFN, 4x4x0.8mm	
APPROVAL	DOCUMENT CONTROL NO. 21-0139
REV. E	2/2

Maxim cannot assume responsibility for use of any circuitry other than circuitry entirely embodied in a Maxim product. No circuit patent licenses are implied. Maxim reserves the right to change the circuitry and specifications without notice at any time.

14 **Maxim Integrated Products, 120 San Gabriel Drive, Sunnyvale, CA 94086 408-737-7600**

Looking for pricing, stock, or lifecycle information?

Click below to explore more details on WIN SOURCE:

 [View MAX1576ETG+ on WIN SOURCE](#)

 [Maxim Integrated](#) Information

Optimize Your Supply Chain with WIN SOURCE Solutions

-  Global Sourcing Solution
-  Obsolete Management
-  Cost Control Management
-  Shortage Management
-  Alternative Solution
-  Excess Inventory Management