



**THE DATASHEET OF
MAX1574ETB+T**



EVALUATION KIT
AVAILABLE

MAXIM

180mA, 1x/2x, White LED Charge Pump in 3mm x 3mm TDFN

MAX1574

General Description

The MAX1574 charge pump drives up to three white LEDs with regulated constant current for uniform intensity. By utilizing adaptive 1x/2x charge-pump modes and very-low-dropout current regulators, it achieves 180mA output drive capability and high efficiency over the 1-cell lithium-battery input voltage range. Fixed-frequency (1MHz) switching allows for tiny external components, and the regulation scheme is optimized to ensure low EMI and low input ripple.

The MAX1574 uses an external resistor to set the full-scale 100% LED current. An enable input (EN) is used for simple on/off control or can be pulsed repeatedly to set lower LED current in multiple steps down to 5%. Once the desired brightness is set, the MAX1574 maintains constant LED current as long as EN is kept high. If EN is kept low for more than 2ms, the MAX1574 enters shutdown.

The MAX1574 is available in a 10-pin 3mm x 3mm TDFN package (0.8mm max height).

Applications

LCD Backlighting
Camera Strobes/Flashes and Movie Lights
Cell Phones/Smart Phones
PDAs, Digital Cameras, and Camcorders

Typical Operating Circuit

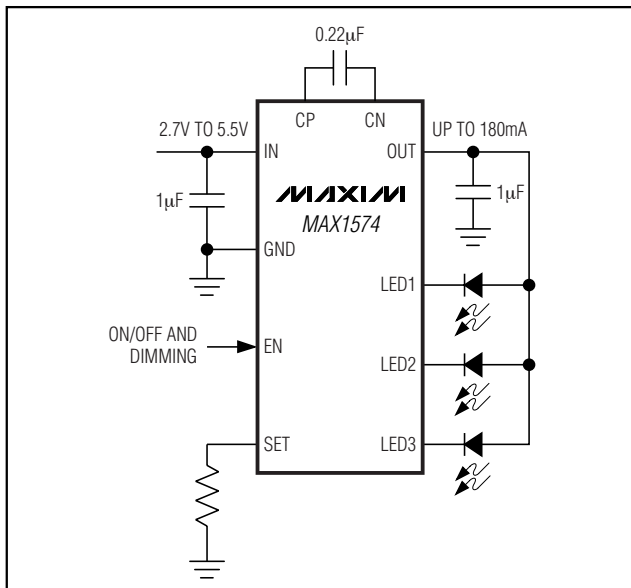

Features

- ◆ Up to 180mA (60mA/LED) Drive Capability
- ◆ 83% Average Efficiency (P_{LED} / P_{BATT}) Over Li+ Battery Discharge
- ◆ 0.5% (typ) LED Current Matching
- ◆ Adaptive 1x/2x Mode Switchover
- ◆ Low Input Ripple and EMI
- ◆ 5% to 100% Dimming Through Single-Wire Serial Pulse Interface
- ◆ Low 0.1µA Shutdown Current
- ◆ 2.7V to 5.5V Supply Voltage Range
- ◆ Soft-Start Limits Inrush Current
- ◆ Output Overvoltage Protection
- ◆ Thermal-Shutdown Protection
- ◆ 10-Pin 3mm x 3mm TDFN Package

Ordering Information

PART	TEMP RANGE	PIN-PACKAGE	TOP MARK
MAX1574ETB	-40°C to +85°C	10 TDFN 3mm x 3mm	ABB

Pin Configuration

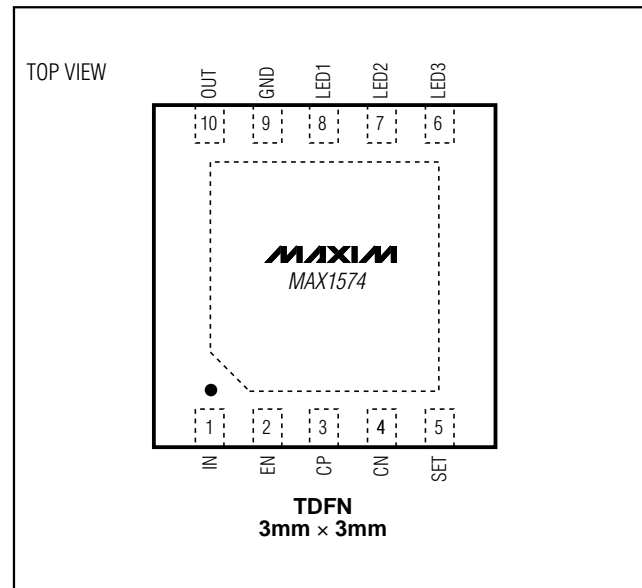

180mA, 1x/2x, White LED Charge Pump in 3mm x 3mm TDFN

ABSOLUTE MAXIMUM RATINGS

IN, OUT, EN to GND-0.3V to +6.0V
 SET, LED1, LED2, LED3, CN to GND-0.3V to (VIN + 0.3V)
 CP to GND-0.3V to
 the greater of (VOUT + 1V) or (VIN + 1V)
 OUT Short Circuit to GNDContinuous

Continuous Power Dissipation (TA = +70°C)
 10-Pin TDFN (derate 18.2mW/°C above +70°C)1454mW
 Operating Temperature Range-40°C to +85°C
 Junction Temperature+150°C
 Storage Temperature Range-65°C to +150°C
 Lead Temperature (soldering, 10s)+300°C

Stresses beyond those listed under "Absolute Maximum Ratings" may cause permanent damage to the device. These are stress ratings only, and functional operation of the device at these or any other conditions beyond those indicated in the operational sections of the specifications is not implied. Exposure to absolute maximum rating conditions for extended periods may affect device reliability.

ELECTRICAL CHARACTERISTICS

(VIN = 3.6V, VGND = 0V, EN = IN, RSET = 13.7kΩ, TA = -40°C to +85°C, unless otherwise noted. Typical values are at TA = +25°C.)
 (Note 1)

PARAMETER	CONDITIONS	MIN	TYP	MAX	UNITS
IN Operating Voltage		2.7		5.5	V
Undervoltage-Lockout Threshold	VIN falling	2.25	2.45	2.60	V
Undervoltage-Lockout Hysteresis			40		mV
Output Overvoltage-Protection Threshold	VOUT rising		5		V
No-Load Supply Current	2x mode		2		mA
	10% setting, 1x mode		0.35		
Shutdown Supply Current	EN = GND, TA = +25°C		0.01	1	μA
	EN = GND, TA = +85°C		0.1		
Soft-Start Time			2		ms
SET Bias Voltage			0.6		V
SET Leakage in Shutdown	EN = GND, TA = +25°C		0.01	1	μA
	EN = GND, TA = +85°C		0.1		
SET Current Range		4		153	μA
SET-to-LED_ Current Ratio (ILED/ISET)	100% setting		393		A/A
LED Current Accuracy	TA = +25°C		±0.7		%
LED-to-LED Current Matching	(Note 2)	-4	±0.5	+4	%
Maximum LED_ Sink Current	RSET = 4.12kΩ	52	60		mA
LED_ Dropout Voltage	RSET = 4.12kΩ (Note 3)		80	120	mV
1x to 2x Mode Transition Threshold	VLED_ falling	120	130	140	mV
Input-Voltage-Mode Transition Hysteresis			150		mV
LED Leakage in Shutdown	EN = GND, TA = +25°C		0.01	2	μA
	EN = GND, TA = +85°C		0.1		
Maximum OUT Current	VIN ≥ 3.12V, VOUT = 3.9V	180			mA
Open-Loop OUT Resistance	1x mode, (VIN - VOUT) / IOUT		1.5	2.5	Ω
	2x mode, (2 x VIN - VOUT) / IOUT		9	15	
Switching Frequency			1		MHz
OUT Pulldown Resistance in Shutdown	EN = GND		5		kΩ
EN High Voltage	VIN = 2.7V to 5.5V	1.6			V
EN Low Voltage	VIN = 2.7V to 5.5V			0.4	V

180mA, 1x/2x, White LED Charge Pump in 3mm x 3mm TDFN

ELECTRICAL CHARACTERISTICS (continued)

($V_{IN} = 3.6V$, $V_{GND} = 0V$, $EN = IN$, $R_{SET} = 13.7k\Omega$, $T_A = -40^\circ C$ to $+85^\circ C$, unless otherwise noted. Typical values are at $T_A = +25^\circ C$.)
(Note 1)

PARAMETER	CONDITIONS	MIN	TYP	MAX	UNITS
EN Input Current	EN = GND or 5.5V, $T_A = +25^\circ C$		0.01	1	μA
	EN = GND or 5.5V, $T_A = +85^\circ C$		0.1		
EN Low Shutdown Delay		1.0	2	3.3	ms
EN t_{LO} (Figure 1)		0.5		500	μs
EN t_{HI} (Figure 1)		0.5			μs
Initial EN t_{HI} (Figure 1)	Only required for first EN_ pulse	50			μs
Thermal-Shutdown Threshold			+160		$^\circ C$
Thermal-Shutdown Hysteresis			20		$^\circ C$

Note 1: Limits are 100% production tested at $T_A = +25^\circ C$. Limits over the operating temperature range are guaranteed by design.

Note 2: LED current matching is defined as: $(I_{LED} - I_{AVG}) / I_{AVG}$

Note 3: Dropout voltage is defined as the LED_-to-GND voltage at which current into LED_ drops 10% from the value at $V_{LED_} = 0.2V$.

Typical Operating Characteristics

(Circuit of Figure 2, $V_{IN} = 3.6V$, $EN = IN$, driving three white LEDs, $T_A = +25^\circ C$, unless otherwise noted.)

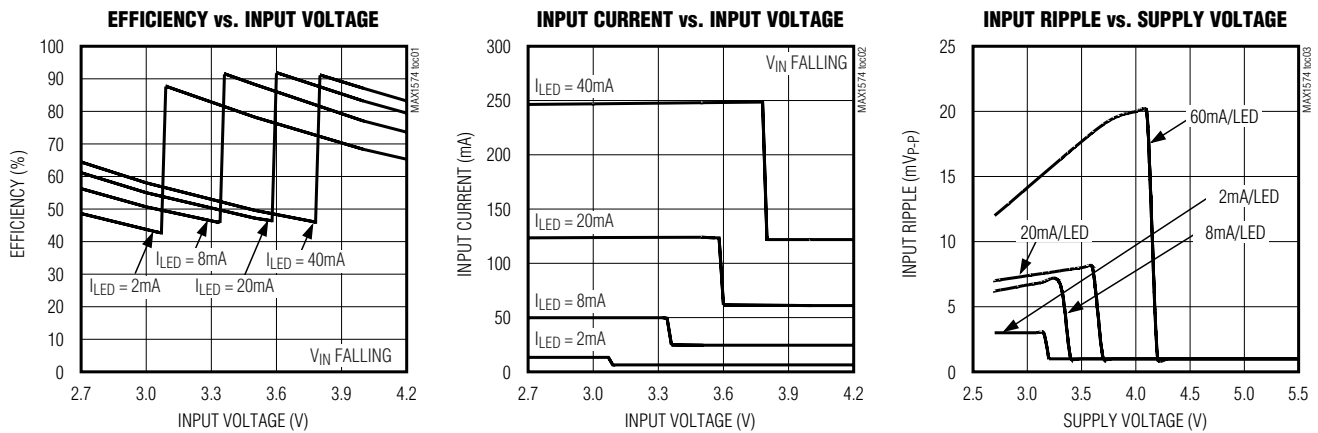

180mA, 1x/2x, White LED Charge Pump in 3mm x 3mm TDFN

Typical Operating Characteristics (continued)

(Circuit of Figure 2, $V_{IN} = 3.6V$, $EN = IN$, driving three white LEDs, $T_A = +25^\circ C$, unless otherwise noted.)

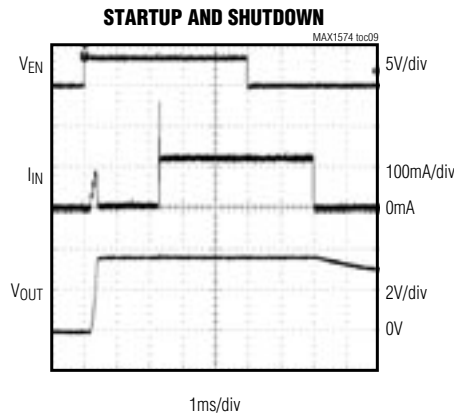
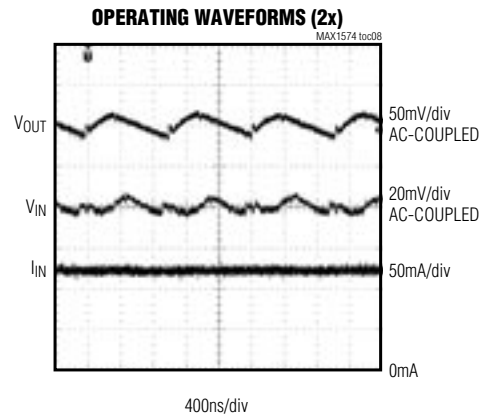
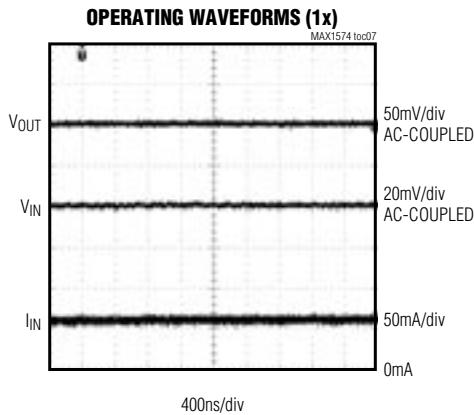
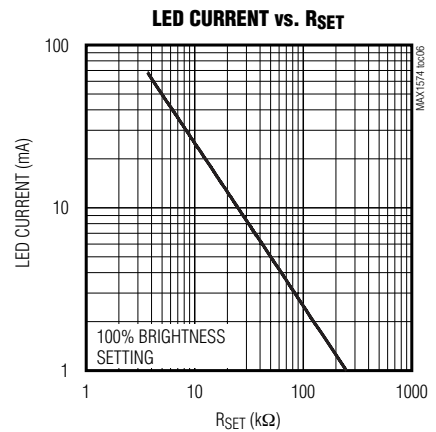
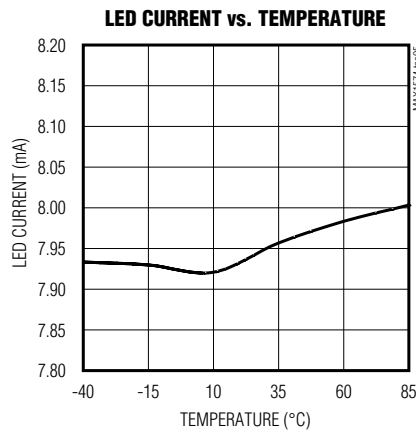
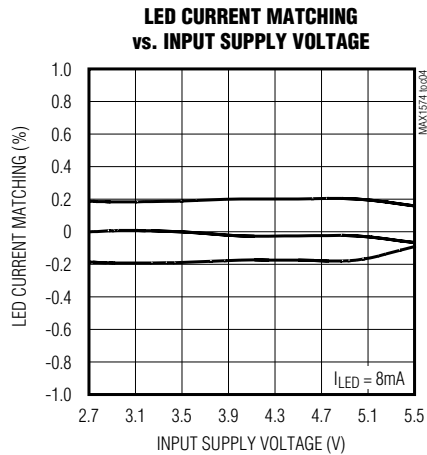

180mA, 1x/2x, White LED Charge Pump in 3mm x 3mm TDFN

MAX1574

Typical Operating Characteristics (continued)

(Circuit of Figure 2, $V_{IN} = 3.6V$, $EN = IN$, driving three white LEDs, $T_A = +25^\circ C$, unless otherwise noted.)

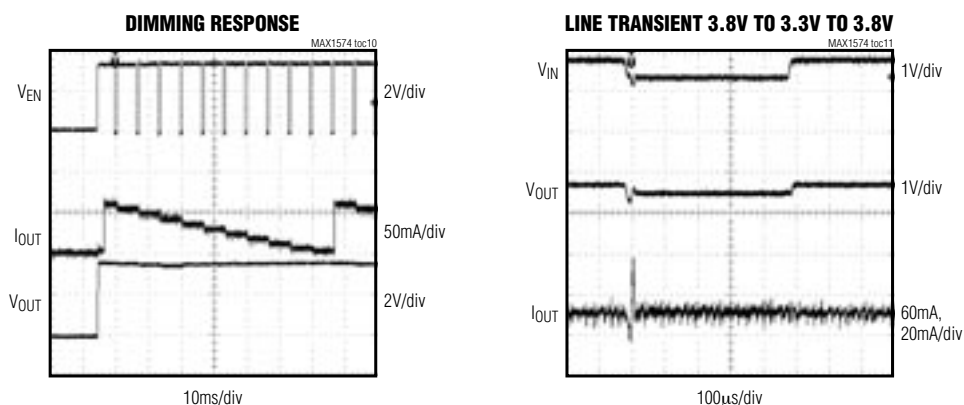

Pin Description

PIN	NAME	FUNCTION
1	IN	Supply Voltage Input. Connect a 0.47µF to 1µF ceramic capacitor from IN to GND. The input voltage range is 2.7V to 5.5V. IN is high impedance during shutdown.
2	EN	Enable and Dimming Control. Pulsing EN low dims the LEDs in multiple steps. Drive low for longer than 2ms (typ) to shut down the IC. From shutdown, drive EN high (50µs min) to set I_{LED} to the maximum current (see the SETfunction). Pulse EN low for 0.5µs to 500µs to dim the LEDs (Figure 1).
3	CP	Transfer-Capacitor Positive Connection. Connect a 0.22µF capacitor from CP to CN.
4	CN	Transfer-Capacitor Negative Connection. Connect a 0.22µF capacitor from CP to CN.
5	SET	Current-Set Input. Connect a resistor (R_{SET}) from SET to GND to set the maximum LED current. $I_{LED(MAX)} = 393 \times 0.6V / R_{SET}$. SET is internally biased to 0.6V. SET is high impedance during shutdown.
6	LED3	LED_ Cathode Connection. Current flowing into LED_ is based on SET description above. In 2x mode, the charge pump regulates the lowest LED_ voltage to 0.18V. Connect LED_ to IN for unpopulated LEDs. LED_ is high impedance during shutdown.
7	LED2	
8	LED1	
9	GND	Ground. Connect GND to system ground and as close as possible to the input-bypass capacitor ground.
10	OUT	Output. Connect a 0.47µF to 1µF ceramic capacitor from OUT to GND, and connect OUT to the anodes of all the LEDs. OUT is pulled to ground through an internal 5kΩ resistor in shutdown.
—	EP	Exposed Paddle. Connect the exposed paddle directly to GND underneath the IC.

180mA, 1x/2x, White LED Charge Pump in 3mm x 3mm TDFN

Detailed Description

The MAX1574 charge pump drives up to three white LEDs with regulated constant current for uniform intensity. By utilizing adaptive 1x/2x charge-pump modes and very-low-dropout current regulators, it achieves 180mA output drive capability and high efficiency over the 1-cell lithium-battery input voltage range. Fixed-frequency switching of 1MHz allows for tiny external components, and the regulation scheme is optimized to ensure low EMI and low input ripple.

1x to 2x Switchover

When V_{IN} is higher than V_{OUT} , the MAX1574 operates in 1x mode and V_{OUT} is pulled up to V_{IN} . The internal current regulators regulate the LED current. As V_{IN} drops, $V_{LED_}$ eventually falls below the switchover threshold of 130mV, and the MAX1574 starts switching in 2x mode. When the input voltage rises above V_{OUT} by approximately 50mV, the MAX1574 switches back to 1x mode.

Soft-Start

The MAX1574 includes soft-start circuitry to limit inrush current at turn-on. When starting up, the output capacitor is charged directly from the input with a ramped current source (with no charge-pump action) until the output voltage approaches the input voltage. Once this occurs, the charge pump determines if 1x or 2x mode is required. In the case of 1x mode, the soft-start is terminated and normal operation begins. During the soft-start time, the output current is set to 5% of the maximum set by R_{SET} . In the case of 2x mode, soft-start operates until the lowest of LED1 to LED3 reaches regulation. If an overload condition occurs, soft-start repeats every 2.1ms. If the output is shorted to ground, the output current is limited by the MAX1574 switching technique.

Setting the Output Current

The LED current at full brightness is set by a resistor, R_{SET} , as follows:

$$R_{SET} = \frac{0.6V \times 393}{I_{LED_}}$$

EN Dimming Control

When the LEDs are enabled by driving EN high, the MAX1574 goes through soft-start, bringing the LED current up to $I_{LED_}$. Dimming is then done by pulsing EN low (500ns to 500 μ s pulse width). Each pulse reduces the LED current by 10%, so after one pulse the LED current is $0.9 \times I_{LED_}$. The tenth pulse reduces the current by 5%, so the $I_{LED_}$ current reduces from $0.1 \times I_{LED_}$ to $0.05 \times I_{LED_}$. The eleventh pulse sets the LED current back to $I_{LED_}$. Figure 1 shows a timing diagram for EN.

If dimming control is not required, EN works as a simple on/off control. Drive EN high to enable the LEDs, or drive EN low for shutdown.

Shutdown Mode

When EN is held low for 2ms or longer, the MAX1574 is shut down and put in a low-current mode. OUT is internally pulled to GND with 5k Ω during shutdown.

Overvoltage Protection

If any LED fails as an open circuit, the output voltage is limited to about 5V by gating on/off the charge pump. If any $LED_$ is floating or grounded, the MAX1574 operates in the same overvoltage-protection mode. To avoid overvoltage-protection mode when using fewer than three LEDs, connect any unused $LED_$ to IN (Figure 3).

Thermal Shutdown

The MAX1574 includes a thermal-limit circuit that shuts down the IC at approximately +160°C. The part turns on after the IC cools by approximately 20°C.

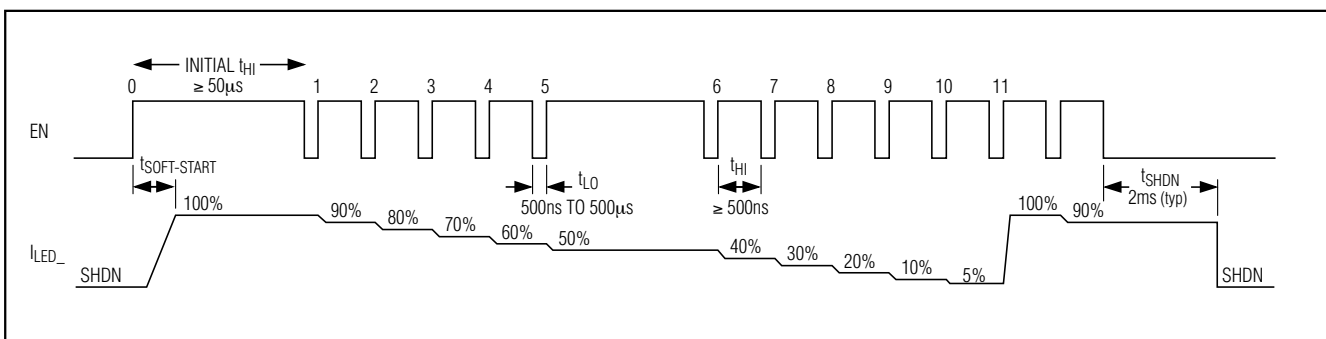

Figure 1. EN Timing Diagram

180mA, 1x/2x, White LED Charge Pump in 3mm x 3mm TDFN

MAX1574

Table 1. Recommended Components

COMPONENT DESIGNATION	VALUE	MANUFACTURER	PART NUMBER	DESCRIPTION
C _{IN} , C _{OUT}	1μF	Taiyo Yuden	JMK107BJ105KA	1μF ±10%, 6.3V X5R ceramic capacitors (0603)
		TDK	C1005X5R0J105M	1μF ±20%, 6.3V X5R ceramic capacitors (0402)
C1	0.22μF	Taiyo Yuden	JMK105BJ224KV	0.22μF ±10%, 6.3V X5R ceramic capacitor (0402)
		TDK	C1005X5R0J224K	0.22μF ±10%, 6.3V X5R ceramic capacitor (0402)
	0.47μF	Taiyo Yuden	JMK105BJ474KV	0.47μF ±10%, 6.3V X5R ceramic capacitor (0402)
		TDK	C1005X5R0J474K	0.47μF ±10%, 6.3V X5R ceramic capacitor (0402)
D1, D2, D3	—	Nichia	NSCW215T	White LEDs
		Citizen	CL-470S	White LED flash module
R _{SET}	As Required	Kamaya	—	1% resistor
		Panasonic		

Applications Information

Driving Fewer than Three LEDs

When driving fewer than three LEDs, connect any unused LED_ directly to IN (Figure 3). When connected in this manner, the corresponding LED driver is disabled.

Driving Camera Strobes/Flashes

The MAX1574's 180mA output capability makes it suitable for driving white LED camera strobes/ flashes. For example, the typical operating circuit drives a 3-LED flash module with up to 60mA/LED. To ensure 180mA total drive capability at low input voltages, increase C1 to 0.47μF.

To drive fewer or more LEDs with regulated total current up to 180mA or to reduce the number of connecting wires, short LED1, LED2, and LED3 together. When connected this way, some LED modules have good LED-to-LED forward-voltage matching, while others may require individual ballast resistors. It is a good idea to keep the ballast resistance as low as practical for reasonable matching because high-ballast resistance reduces the output drive capability due to the higher V_{OUT} requirement.

Input Ripple

For LED drivers, input ripple is more important than output ripple. Input ripple depends on the source supply's impedance. Adding a lowpass filter to the input further reduces input ripple. Alternatively, increasing C_{IN} to 2.2μF cuts input ripple in half with only a small increase in footprint. The 1x mode always has very low input ripple.

Component Selection

Use only ceramic capacitors with an X5R, X7R, or better dielectric. See Table 1 for a list of recommended parts.

PC Board Layout and Routing

The MAX1574 is a high-frequency switched-capacitor voltage regulator. For best circuit performance, use a solid ground plane and place C_{IN}, C_{OUT}, and C1 as close to the MAX1574 as possible. Refer to the MAX1574 evaluation kit for an example.

180mA, 1x/2x, White LED Charge Pump in 3mm x 3mm TDFN

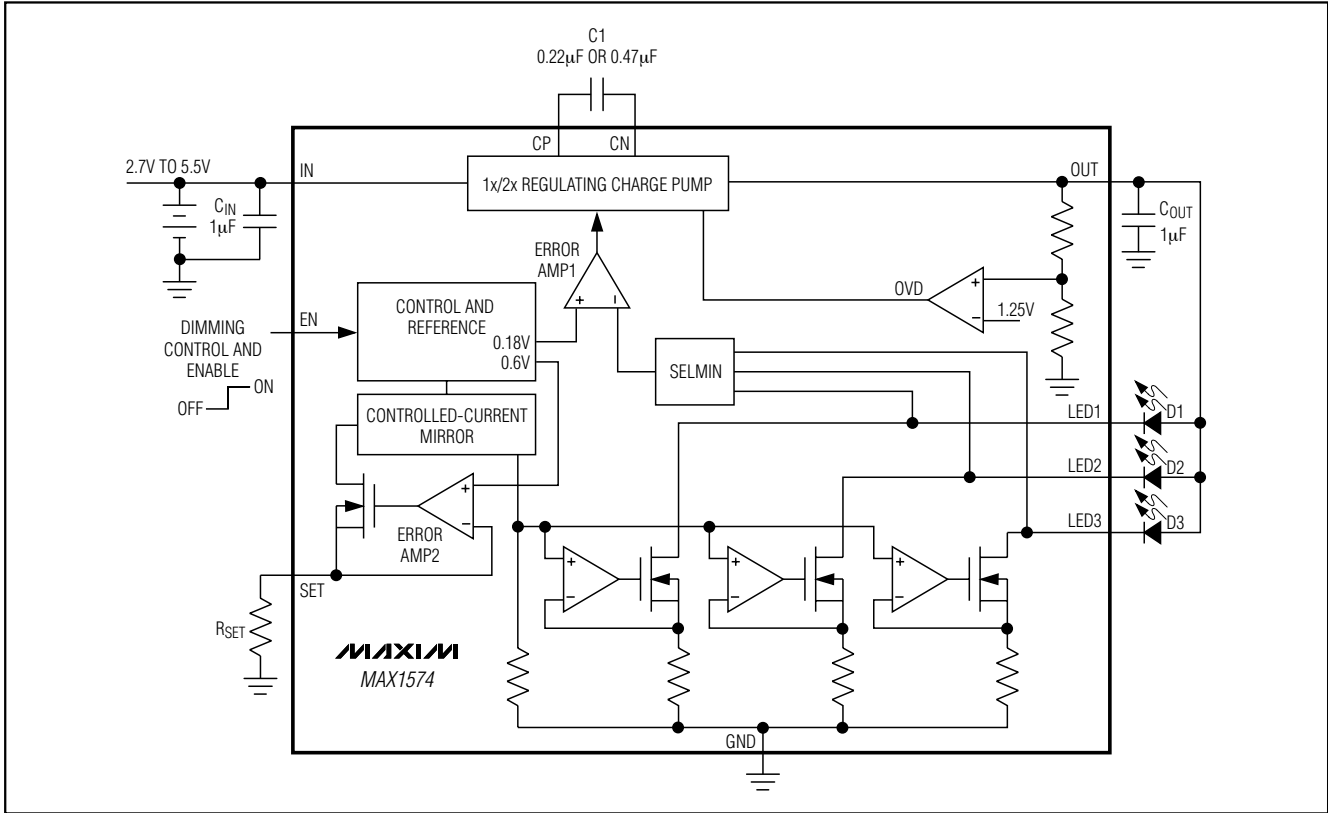

Figure 2. Functional Diagram and Typical Application Circuit

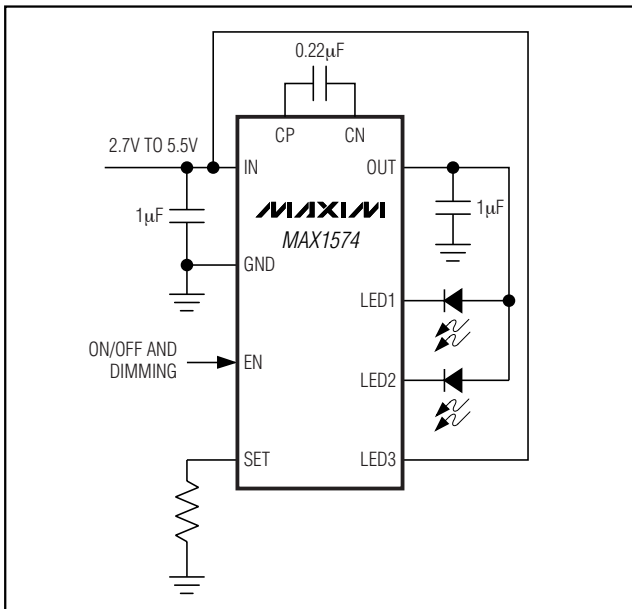

Figure 3. Using the MAX1574 to Drive Fewer Than Three LEDs

Chip Information

TRANSISTOR COUNT: 6063
PROCESS: BiCMOS

180mA, 1x/2x, White LED Charge Pump in 3mm x 3mm TDFN

Package Information

(The package drawing(s) in this data sheet may not reflect the most current specifications. For the latest package outline information, go to www.maxim-ic.com/packages.)

MAX1574

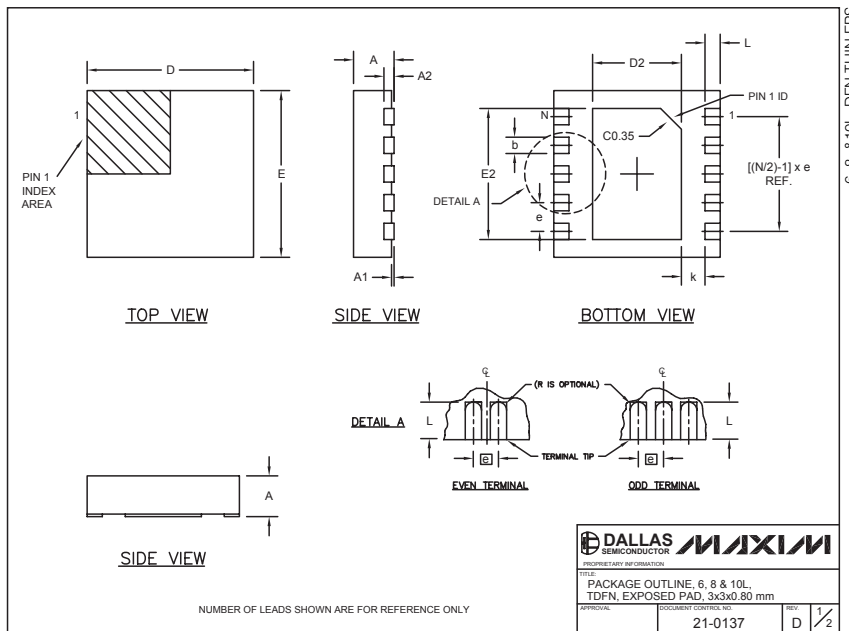

COMMON DIMENSIONS						
SYMBOL	MIN.	MAX.				
A	0.70	0.80				
D	2.90	3.10				
E	2.90	3.10				
A1	0.00	0.05				
L	0.20	0.40				
k	0.25 MIN.					
A2	0.20 REF.					

PACKAGE VARIATIONS							
PKG. CODE	N	D2	E2	e	JEDEC SPEC	b	[(N/2)-1] x e
T633-1	6	1.50±0.10	2.30±0.10	0.95 BSC	MO229 / WEEA	0.40±0.05	1.90 REF
T833-1	8	1.50±0.10	2.30±0.10	0.65 BSC	MO229 / WEEC	0.30±0.05	1.95 REF
T1033-1	10	1.50±0.10	2.30±0.10	0.50 BSC	MO229 / WEED-3	0.25±0.05	2.00 REF

NOTES:

- ALL DIMENSIONS ARE IN mm, ANGLES IN DEGREES.
- COPLANARITY SHALL NOT EXCEED 0.08 mm.
- WARPAGE SHALL NOT EXCEED 0.10 mm.
- PACKAGE LENGTH/PACKAGE WIDTH ARE CONSIDERED AS SPECIAL CHARACTERISTIC(S).
- DRAWING CONFORMS TO JEDEC MO229, EXCEPT DIMENSIONS "D2" AND "E2".
- "N" IS THE TOTAL NUMBER OF LEADS.

DALLAS SEMICONDUCTOR		MAXIM	
PROPERTY OF MAXIM INTEGRATED PRODUCTS			
TITLE: PACKAGE OUTLINE, 6, 8 & 10L, TDFN, EXPOSED PAD, 3x3x0.80 mm			
APPROVAL:	DOCUMENT CONTROL NO:	REV:	2/2
	21-0137	D	

Maxim cannot assume responsibility for use of any circuitry other than circuitry entirely embodied in a Maxim product. No circuit patent licenses are implied. Maxim reserves the right to change the circuitry and specifications without notice at any time.

Maxim Integrated Products, 120 San Gabriel Drive, Sunnyvale, CA 94086 408-737-7600 _____ **9**

Looking for pricing, stock, or lifecycle information?

Click below to explore more details on WIN SOURCE:

 [View MAX1574ETB+T on WIN SOURCE](#)

 [Maxim Integrated Information](#)

Optimize Your Supply Chain with WIN SOURCE Solutions

-  Global Sourcing Solution
-  Obsolete Management
-  Cost Control Management
-  Shortage Management
-  Alternative Solution
-  Excess Inventory Management