



**THE DATASHEET OF
MAX1573ETE+T**





White LED 1x/1.5x Charge Pump in UCSP and Thin QFN

MAX1573

General Description

The MAX1573 fractional charge pump drives up to four white LEDs with regulated constant current for uniform intensity. By utilizing proprietary adaptive 1x/1.5x modes and ultra-low-dropout current regulators, it maintains the highest possible efficiency over the full 1-cell Li+ battery input voltage range. The 1MHz fixed-frequency switching allows for tiny external components and the regulation scheme is optimized to ensure low EMI and low input ripple.

An external resistor sets the full-scale LED current, while two digital inputs control on/off and select amongst three levels of brightness. A pulse-width modulation (PWM) signal can also be used to modulate LED brightness, requiring no additional components.

The MAX1573 is available in the tiny chip-scale UCSP™ (4 x 4 grid) and 16-pin thin QFN packages.

Applications

Cell Phones, Smart Phones
PDAs, Digital Cameras, Camcorders
MP3 Players
Other Handhelds with Color Displays

Features

- ◆ Proprietary Adaptive 1x/1.5x Modes
- ◆ High Efficiency (PLEDs/PBATT), Up to 92%
- ◆ 0.2% LED Current Matching
- ◆ 28mA/LED Drive Capability
- ◆ Low Input Ripple and EMI
- ◆ Eliminates Ballast Resistors
- ◆ Logic or PWM Dimming Control
- ◆ Low 0.1µA Shutdown Current
- ◆ 2.7V to 5.5V Input Voltage Range
- ◆ Soft-Start Limits Inrush Current
- ◆ Output Overvoltage Protection
- ◆ Thermal Shutdown Protection
- ◆ No External Schottky Diode Required
- ◆ Tiny UCSP (2.1mm x 2.1mm x 0.6mm) and Thin QFN (4mm x 4mm) Packages

Ordering Information

PART	TEMP RANGE	PIN-PACKAGE
MAX1573EBE-T	-40°C to +85°C	14 UCSP (4 x 4)
MAX1573ETE	-40°C to +85°C	16 Thin QFN
MAX1573ETE+	-40°C to +85°C	16 Thin QFN

+ Denotes lead-free package.

Typical Operating Circuit

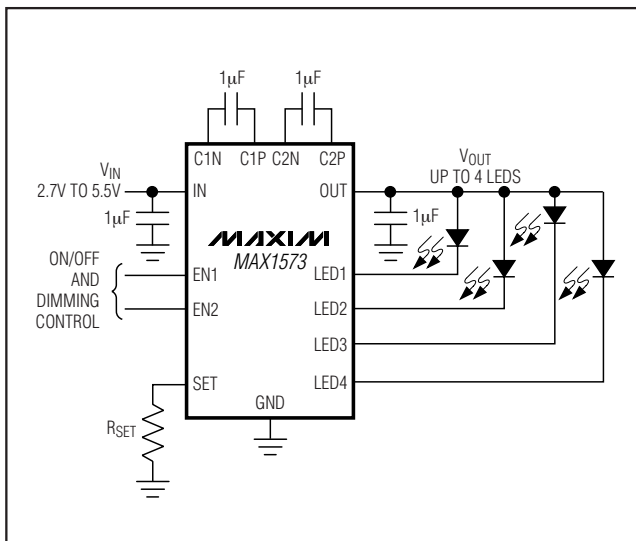

UCSP is a trademark of Maxim Integrated Products, Inc.

Pin Configurations

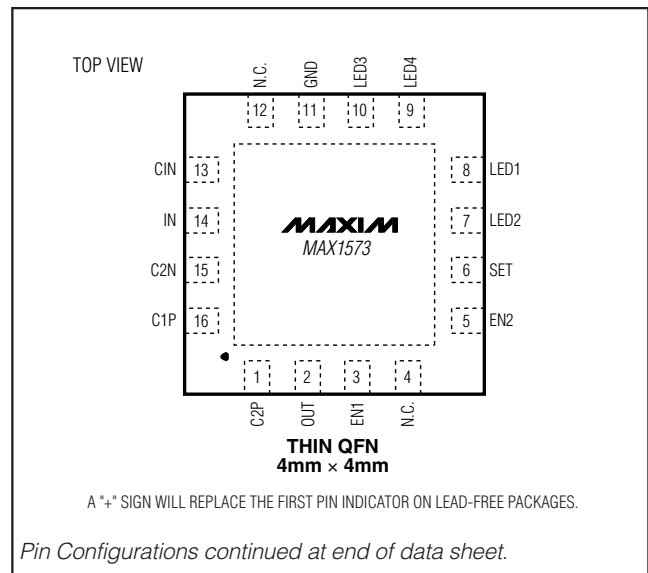

White LED 1x/1.5x Charge Pump in UCSP and Thin QFN

ABSOLUTE MAXIMUM RATINGS

IN, OUT, EN1, EN2 to GND	-0.3V to +6.0V
SET, LED1, LED2, LED3, LED4 to GND	-0.3V to (V _{IN} + 0.3V)
C1N, C2N to GND	-0.3V to (V _{IN} + 1V)
C1P, C2P to GND	-0.3V to greater of (V _{OUT} + 1V) or (V _{IN} + 1V)
OUT Short Circuit to GND	Continuous

Continuous Power Dissipation (T _A = +70°C)	
14-Bump UCSP (derate 7.36mW/°C above +70°C)	589mW
16-Pin Thin QFN (derate 16.9mW/°C above +70°C) .	1349mW
Operating Temperature Range	-40°C to +85°C
Junction Temperature	+150°C
Storage Temperature Range	-65°C to +150°C

Stresses beyond those listed under "Absolute Maximum Ratings" may cause permanent damage to the device. These are stress ratings only, and functional operation of the device at these or any other conditions beyond those indicated in the operational sections of the specifications is not implied. Exposure to absolute maximum rating conditions for extended periods may affect device reliability.

ELECTRICAL CHARACTERISTICS

(V_{IN} = V_{EN1} = V_{EN2} = 3.6V, C_{IN} = C₁ = C₂ = C_{OUT} = 1μF, T_A = -40°C to +85°C. Typical values are at T_A = +25°C, unless otherwise noted.) (Note 1)

PARAMETER	CONDITIONS	MIN	TYP	MAX	UNITS	
IN Operating Voltage		2.7		5.5	V	
Undervoltage Lockout Threshold	V _{IN} rising or falling, 35mV hysteresis	2.25	2.45	2.60	V	
Supply Current	Switching, no load, I _{SET} = 130μA		2	4	mA	
Shutdown Supply Current	EN1 = EN2 = OUT = GND, T _A = +25°C		0.1	10	μA	
Soft-Start Completion Time			2.1		ms	
SET Bias Voltage		0.570	0.6	0.630	V	
SET Leakage in Shutdown	EN1 = EN2 = GND, T _A = +25°C		0.01	1	μA	
SET Current Range		40		130	μA	
SET to LED_ Current Ratio (I _{LED} /I _{SET})	I _{SET} = 60μA	EN1 = EN2 = IN	190	219	245	A/A
		EN1 = IN, EN2 = GND	58	66	74	
		EN1 = GND, EN2 = IN	19.5	22	25.0	
LED_ Current Accuracy	EN1 = EN2 = IN, R _{SET} = 4.64kΩ, T _A = 0°C to +85°C		±0.6		%	
LED_ Current Matching	I _{SET} = 130μA, T _A = 0°C to +85°C (Note 2)		±0.2		%	
Maximum LED_ Sink Current	I _{SET} = 130μA, EN1 = EN2 = IN	25.9	28		mA	
LED_ Dropout Voltage	I _{SET} = 87μA (Note 3)		40	80	mV	
LED_ Minimum Regulation Voltage (1.5x Mode)	EN1 = EN2 = IN, I _{SET} = 87μA	100	150	200	mV	
LED Leakage in Shutdown	EN1 = EN2 = GND, V _{LED} = 5.5V, T _A = +25°C		0.01	1	μA	
Maximum OUT Current	V _{IN} ≥ 3.4V, V _{OUT} ≥ 3.9V, EN1 = EN2 = IN	120			mA	
Open-Loop OUT Resistance	1x mode (1 × V _{IN} - V _{OUT}) / I _{OUT}			1.5	Ω	
	1.5x mode (1.5 × V _{IN} - V _{OUT}) / I _{OUT}			10		
Switching Frequency			1		MHz	
EN1, EN2 Logic High Voltage	V _{IN} = 2.7V to 5.5V	1.6			V	
EN1, EN2 Logic Low Voltage	V _{IN} = 2.7V to 5.5V			0.4	V	
EN1, EN2 Input Current	V _{EN_} = GND or 5.5V, T _A = +25°C		0.01	1	μA	
Thermal-Shutdown Threshold	20°C hysteresis		160		°C	

Note 1: Specifications to -40°C are guaranteed by design and not production tested.

Note 2: LED_ current matching is defined as: (I_{LED} - I_{AVG}) / I_{AVG}.

Note 3: Dropout voltage is defined as the LED_ to GND voltage at which the LED_ current drops 10% from the value at V_{LED} = 200mV.

White LED 1x/1.5x Charge Pump in UCSP and Thin QFN

MAX1573

Typical Operating Characteristics

($V_{IN} = 3.6V$, $EN1 = EN2 = IN$, $C_{IN} = C1 = C2 = C_{OUT} = 1\mu F$, $R_{SET} = 7.50k\Omega$, $T_A = +25^\circ C$, unless otherwise noted.)

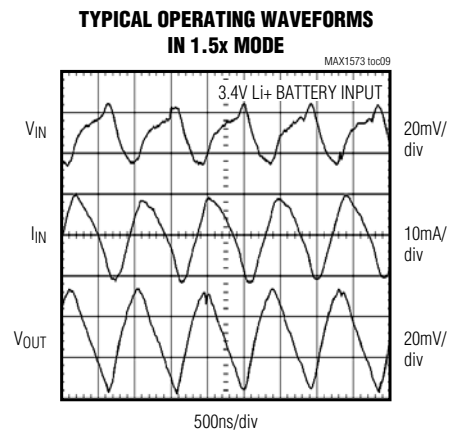
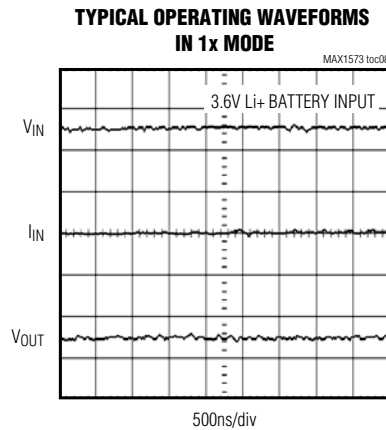
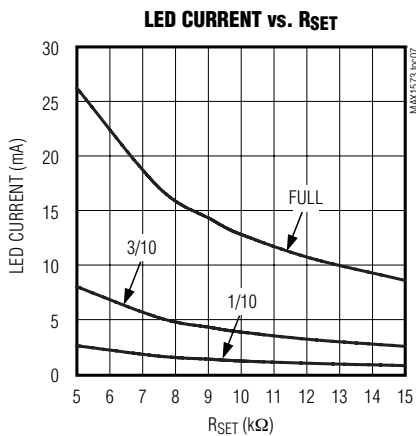
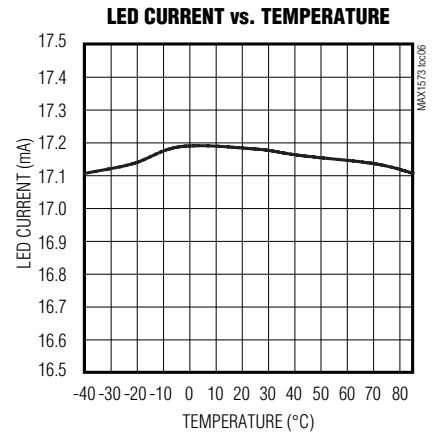
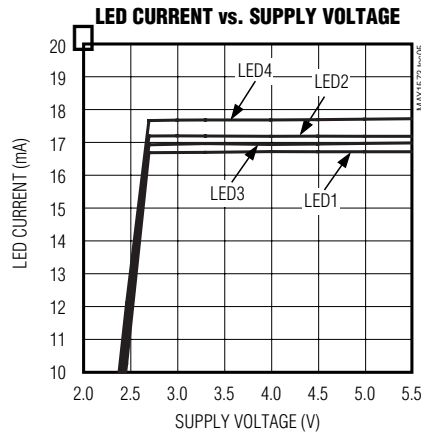
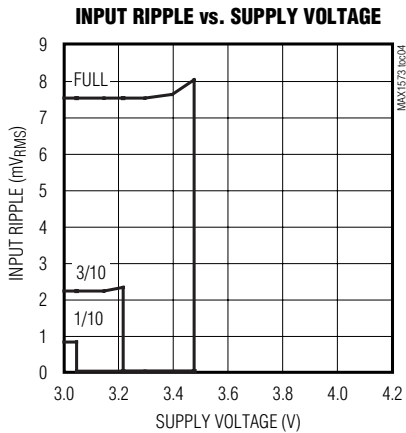
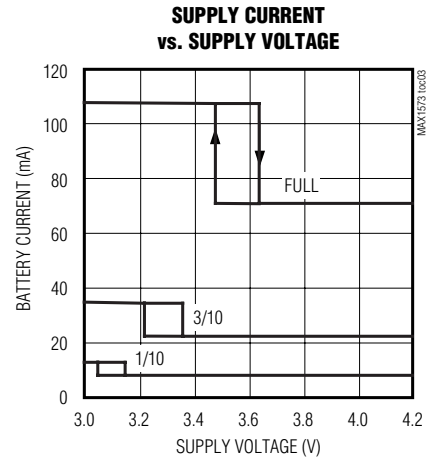
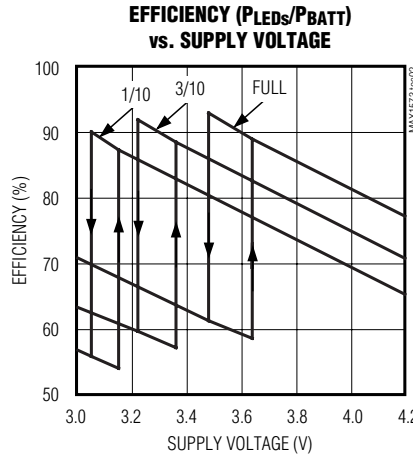
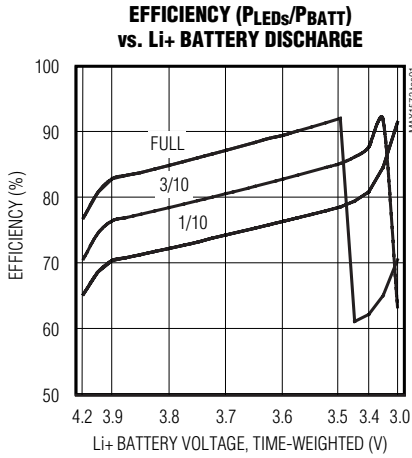

White LED 1x/1.5x Charge Pump in UCSP and Thin QFN

Typical Operating Characteristics (continued)

($V_{IN} = 3.6V$, $EN1 = EN2 = IN$, $C_{IN} = C1 = C2 = C_{OUT} = 1\mu F$, $R_{SET} = 7.50k\Omega$, $T_A = +25^\circ C$, unless otherwise noted.)

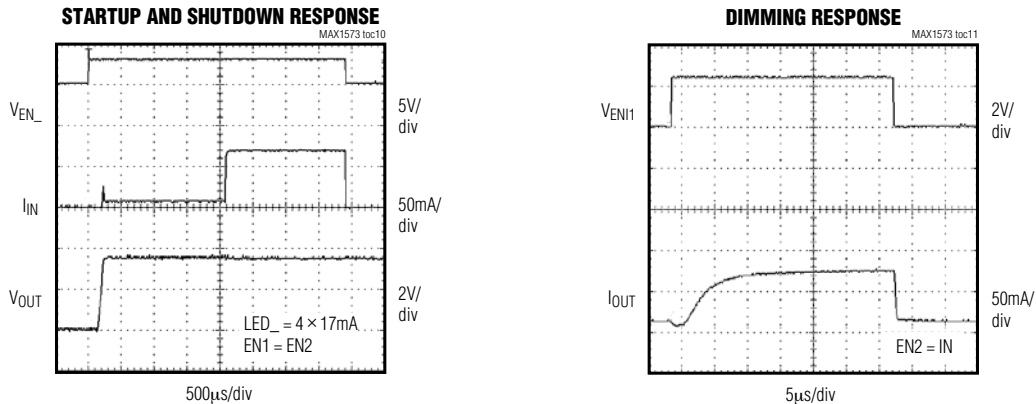

Pin Description

PIN		NAME	FUNCTION
TQFN	UCSP		
1	B2	C2P	Transfer Capacitor 2 Positive Connection. See the <i>Component Selection</i> section for capacitor value.
2	A2	OUT	Output. Bypass to GND with a 1 μF ceramic capacitor. Connect to the anodes of all the LEDs. OUT is high impedance during shutdown.
3	A3	EN1	Enable, Dimming Control Input 1. EN1 and EN2 control shutdown and the LED current. See Table 1.
4	—	N.C.	No Connection
5	A4	EN2	Enable, Dimming Control Input 2. EN1 and EN2 control shutdown and the LED current. See Table 1.
6	B4	SET	Bias-Current Set Input. Connect a resistor from SET to GND to set the LED bias current (I_{SET}). $I_{SET} = 600mV/R_{SET}$.
7	C4	LED2	LED2 Cathode Connection and Charge-Pump Feedback. The charge pump regulates to the lowest voltage on any of the LED_ inputs. Connect LED2 to the cathode of one output LED. Connect LED2 to IN if this LED is not populated.
8	D4	LED1	LED1 Cathode Connection and Charge-Pump Feedback. The charge pump regulates to the lowest voltage on any of the LED_ inputs. Connect LED1 to the cathode of one output LED. Connect LED1 to IN if this LED is not populated.
9	C3	LED4	LED4 Cathode Connection and Charge-Pump Feedback. The charge pump regulates to the lowest voltage on any of the LED_ inputs. Connect LED4 to the cathode of one output LED. Connect LED4 to IN if this LED is not populated.
10	D3	LED3	LED3 Cathode Connection and Charge-Pump Feedback. The charge pump regulates to the lowest voltage on any of the LED_ inputs. Connect LED3 to the cathode of one output LED. Connect LED3 to IN if this LED is not populated.
11	D2	GND	Ground
12	—	N.C.	No Connection

White LED 1x/1.5x Charge Pump in UCSP and Thin QFN

MAX1573

Pin Description (continued)

PIN		NAME	FUNCTION
TQFN	UCSP		
13	D1	C1N	Transfer Capacitor 1 Negative Connection. See the <i>Component Selection</i> section for capacitor value.
14	C1	IN	Supply Voltage Input. IN supplies power for the IC. Bypass IN to GND with a 1 μ F ceramic capacitor.
15	B1	C2N	Transfer Capacitor 2 Negative Connection. See the <i>Component Selection</i> section for capacitor value.
16	A1	C1P	Transfer Capacitor 1 Positive Connection. See the <i>Component Selection</i> section for capacitor value.

Block Diagram

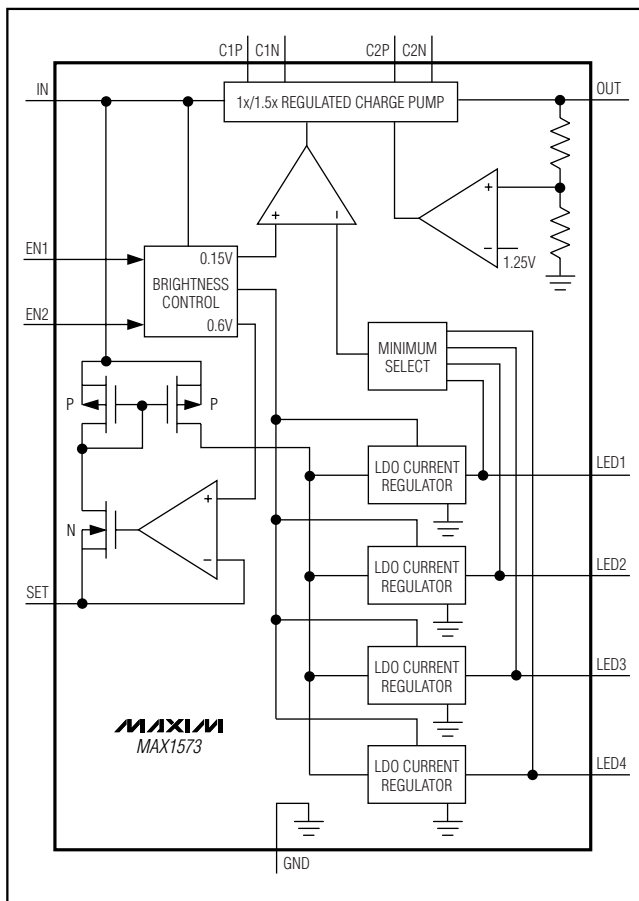

The MAX1573 utilizes a proprietary 1x/1.5x fractional charge-pump topology to drive up to four white LEDs with regulated constant current for uniform intensity. The MAX1573 operates with a 1MHz fixed frequency. An external resistor (R_{SET}) programs the full-scale LED current, while two digital inputs control on/off and provide brightness control.

Output Regulation

The MAX1573 operates in 1x mode until just above dropout. Then the MAX1573 switches to 1.5x charge-pump mode to regulate the lowest of LED1–LED4 to 150mV and maintain constant LED brightness even at very low battery voltages. Using this topology, there is no LED brightness change during the 1x/1.5x switchover, which guarantees no flicker on the display. The switchover scheme has low hysteresis, minimizing operation in the less-efficient 1.5x mode. The 1x mode produces almost no ripple, while the 1.5x mode regulates the output voltage by controlling the rate at which the transfer capacitors are charged. In this way, the switching frequency remains constant for reduced input ripple and stable noise spectrum.

Soft-Start

The MAX1573 includes soft-start circuitry to limit inrush current at turn-on. When starting up with an output voltage that is not near the input voltage, the output capacitor is charged directly from the input with a DAC-ramped current source (with no charge-pump action) until the output voltage is near the input voltage. Once this occurs, the charge pump determines if 1x or 1.5x mode is required. In the case of 1x mode, the soft-start is terminated and normal operation begins. In the case of 1.5x mode, soft-start operates until the lowest of LED1–LED4 reaches regulation. If an overload condition occurs, soft-start repeats every 2.1ms. If the output is shorted to ground, the output current is limited by the MAX1573 fractional-switching technique.

Detailed Description

The MAX1573 is a complete charge-pump buck-boost converter requiring only four small ceramic capacitors.

White LED 1x/1.5x Charge Pump in UCSP and Thin QFN

True Shutdown™ Mode

When EN1 and EN2 are grounded, the MAX1573 is in shutdown, and the charge pump examines whether the input voltage is greater than or less than the output voltage and shorts the transfer capacitor nodes to either IN or OUT as necessary. The output is high impedance in either case.

Thermal Shutdown

The MAX1573 includes a thermal-limit circuit that shuts down the IC at about +160°C. Turn-on occurs after the IC cools by approximately 20°C.

Setting the Output Current

SET controls the LED bias current. Current flowing into LED1, LED2, LED3, and LED4 is a multiple of the current flowing out of SET. Set the output current as follows:

$$I_{LED_} = K \times \left(\frac{0.6V}{R_{SET}} \right)$$

where K = 22, 66, or 219 (depending upon EN1 and EN2, see Table 1), and RSET is the resistor connected between SET and GND (see the *Typical Operating Circuit*).

Table 1. EN1/EN2 States

EN1/EN2 STATES	BRIGHTNESS	LED CURRENT
EN1 = low, EN2 = low	Shutdown	$I_{LED} = 0$
EN1 = low, EN2 = high	1/10 Brightness	$I_{LED} = 22 \times I_{SET}$
EN1 = high, EN2 = low	3/10 Brightness	$I_{LED} = 66 \times I_{SET}$
EN1 = high, EN2 = high	Full Brightness	$I_{LED} = 219 \times I_{SET}$

True Shutdown is a trademark of Maxim Integrated Products, Inc.

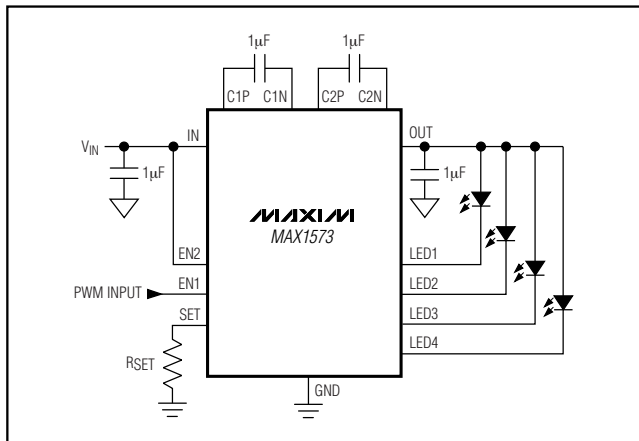

Figure 1. Dimming Using PWM Signal into EN1

Applications Information

Dimming Using EN1 and EN2

Use EN1 and EN2 inputs as a digital 2-bit number to control on/off, 1/10, 3/10, and full current (see Table 1). RSET programs the full current level (see the *Setting the Output Current* section).

Dimming Using PWM into EN1

Use EN2 for shutdown and drive EN1 with a PWM signal. Current can be varied from 1/10 to full. The waveforms in the *Typical Operating Characteristics* show the response time of dimming. EN2 keeps the part on, eliminating any soft-start delay that would impede PWM control, allowing a PWM frequency up to 50kHz (Figure 1).

Dimming Using a Filtered PWM Signal

Use a high-frequency PWM signal to drive an R-C filter on the SET pin (Figure 2). A 0% PWM duty cycle corresponds to 18.7mA/LED, while a 100% PWM duty cycle corresponds to 0mA/LED. At PWM frequencies above 5kHz, C3 may be reduced.

Input Ripple

For LED drivers, input ripple is more important than output ripple. Input ripple depends on the source supply's impedance. Adding a lowpass filter to the input further reduces input ripple. Figure 3 shows a C-R-C filter used to reduce input ripple to less than 2mV_{P-P} when driving a 75mA load. Alternately, increasing C_{IN} to 2.2µF or 4.7µF yields input ripple of 17mV_{P-P} or 9mV_{P-P}, respectively, with only a small increase in footprint. The 1x mode always has very low input ripple.

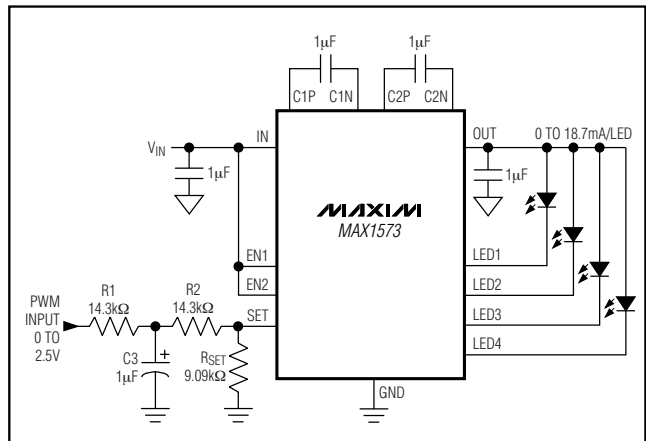

Figure 2. Dimming Using Filtered PWM Signal

White LED 1x/1.5x Charge Pump in UCSP and Thin QFN

PC Board Layout and Routing

The MAX1573 is a high-frequency switched-capacitor voltage regulator. For best circuit performance, use a solid ground plane and place C_{IN} and C_{OUT} as close to the MAX1573 as possible. Also, place their ground pads close together and as close as possible to GND. See the MAX1573 EV kit for an example.

Component Selection

Use ceramic capacitors with an X5R dielectric or better temperature coefficient. The transfer capacitors may be reduced in value if the input voltage does not fall below

3.4V, if only two or three LEDs are used, or if four LEDs are used at 10mA or less. Some typical external component values are shown in Table 2.

Under normal operating conditions, power dissipation is low. Maximum power dissipation occurs at an input voltage of 4.2V and all four LEDs (with V_F = 4V) are driven with 30mA per LED. The power is calculated as:

$$P_D = [(1.5 \times V_{IN}) - V_F] \times 120\text{mA} = 276\text{mW}$$

At higher input voltages, the MAX1573 switches to 1x mode and power dissipation decreases.

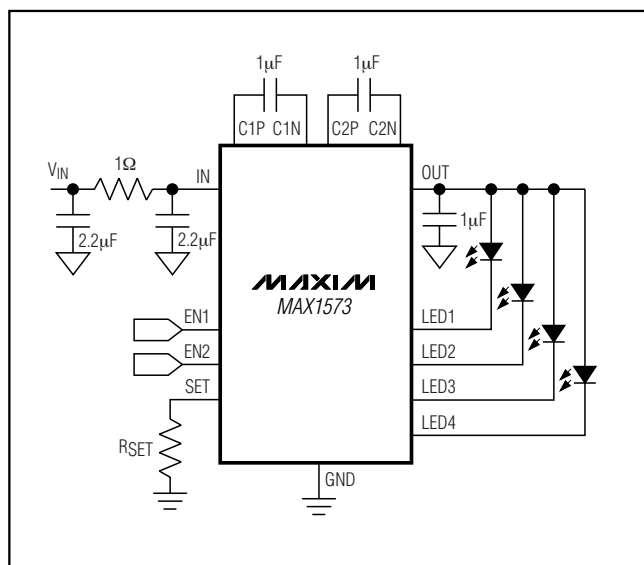

Figure 3. C-R-C Filter Reduces Input Ripple

Pin Configurations (continued)

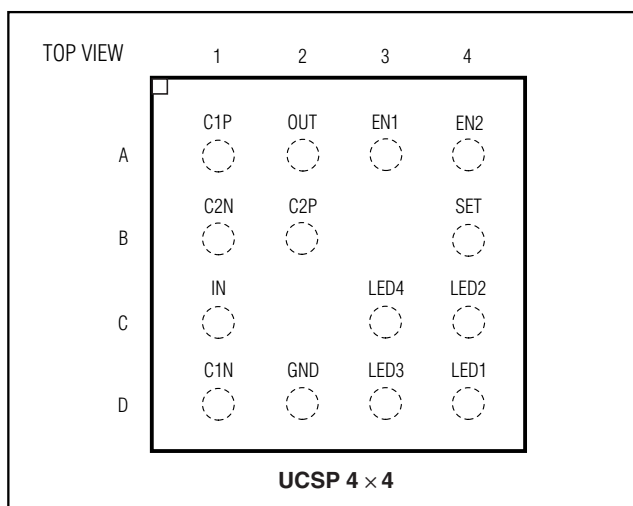

Table 2. Typical Component Values

COMPONENT	VALUE (μF)	MANUFACTURER	PART	DESCRIPTION
Input/Output Capacitors	1	Taiyo Yuden	JMK107BJ105KA	1μF ±10%, 6.3V X5R ceramic capacitor (0603)
Transfer Capacitors	1	Taiyo Yuden	JMK107BJ105KA	1μF ±10%, 6.3V X5R ceramic capacitor (0603)
	0.47	Taiyo Yuden	LMK107BJ474KA	0.47μF ±10%, 10V X5R ceramic capacitor (0603)
	0.22	Taiyo Yuden	LMK107BJ224KA	0.22μF ±10%, 10V X7R ceramic capacitor (0603)
LED	—	Nichia	NSCW215T	White LEDs
RSET	As required	Panasonic	—	±1% resistor (0603)

Chip Information

TRANSISTOR COUNT: 3655

PROCESS: BiCMOS

White LED 1x/1.5x Charge Pump in UCSP and Thin QFN

Package Information

(The package drawing(s) in this data sheet may not reflect the most current specifications. For the latest package outline information, go to www.maxim-ic.com/packages.

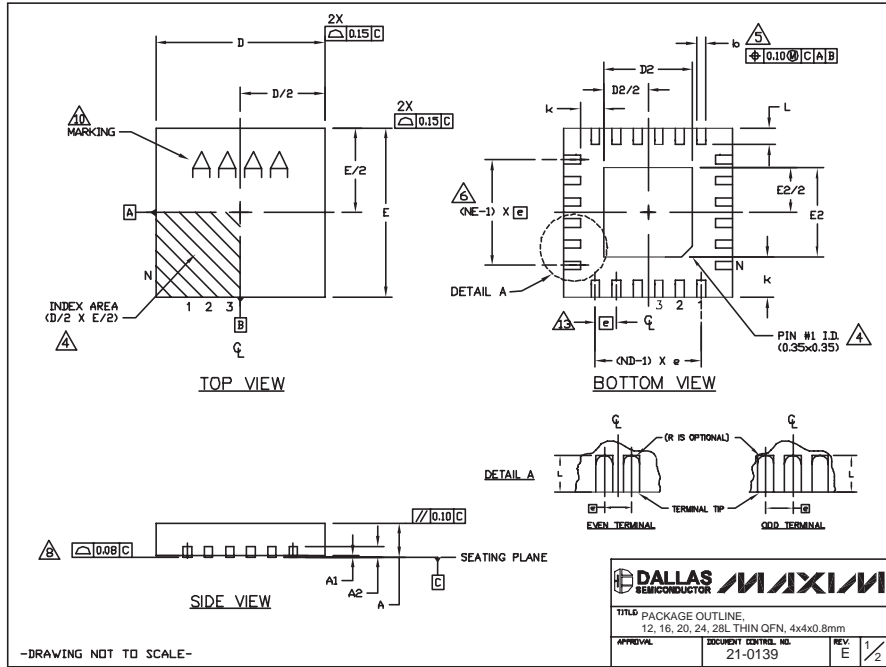

PKG REF.	COMMON DIMENSIONS														
	12L 4x4			16L 4x4			20L 4x4			24L 4x4			28L 4x4		
	MIN.	NOM.	MAX.	MIN.	NOM.	MAX.	MIN.	NOM.	MAX.	MIN.	NOM.	MAX.	MIN.	NOM.	MAX.
A	0.70	0.75	0.80	0.70	0.75	0.80	0.70	0.75	0.80	0.70	0.75	0.80	0.70	0.75	0.80
A1	0.0	0.02	0.05	0.0	0.02	0.05	0.0	0.02	0.05	0.0	0.02	0.05	0.0	0.02	0.05
A2	0.20 REF.			0.20 REF.			0.20 REF.			0.20 REF.			0.20 REF.		
b	0.25	0.30	0.35	0.25	0.30	0.35	0.25	0.30	0.35	0.25	0.30	0.35	0.25	0.30	0.35
D	3.90	4.00	4.10	3.90	4.00	4.10	3.90	4.00	4.10	3.90	4.00	4.10	3.90	4.00	4.10
E	3.90	4.00	4.10	3.90	4.00	4.10	3.90	4.00	4.10	3.90	4.00	4.10	3.90	4.00	4.10
e	0.80 BSC.			0.65 BSC.			0.50 BSC.			0.50 BSC.			0.40 BSC.		
k	0.25	-	-	0.25	-	-	0.25	-	-	0.25	-	-	0.25	-	-
L	0.43	0.53	0.63	0.43	0.53	0.63	0.43	0.53	0.63	0.30	0.40	0.50	0.30	0.40	0.50
N	12			16			20			24			28		
ND	3			4			5			6			7		
NE	3			4			5			6			7		
WDec Var.	WGGB			WGGC			WGGD-1			WGGD-2			WGGE		

PKG CODES	D2			E2			DOWN BONDS ALLOWED
	MIN.	NOM.	MAX.	MIN.	NOM.	MAX.	
T1244-3	1.95	2.10	2.25	1.95	2.10	2.25	YES
T1244-4	1.95	2.10	2.25	1.95	2.10	2.25	NO
T1644-3	1.95	2.10	2.25	1.95	2.10	2.25	YES
T1644-4	1.95	2.10	2.25	1.95	2.10	2.25	NO
T2844-2	1.95	2.10	2.25	1.95	2.10	2.25	YES
T2844-3	1.95	2.10	2.25	1.95	2.10	2.25	NO
T2444-2	1.95	2.10	2.25	1.95	2.10	2.25	YES
T2444-3	2.45	2.60	2.63	2.45	2.60	2.63	YES
T2444-4	2.45	2.60	2.63	2.45	2.60	2.63	NO
T2844-1	2.50	2.60	2.70	2.50	2.60	2.70	NO

DALLAS SEMICONDUCTOR **MAXIM**

TITLE PACKAGE OUTLINE:
12, 16, 20, 24, 28L THIN QFN, 4x4x0.8mm

APPROVAL: 21-0139 REV: E 2/2

- NOTES:
1. DIMENSIONING & TOLERANCING CONFORM TO ASME Y14.5M-1994.
 2. ALL DIMENSIONS ARE IN MILLIMETERS. ANGLES ARE IN DEGREES.
 3. N IS THE TOTAL NUMBER OF TERMINALS.
 4. THE TERMINAL #1 IDENTIFIER AND TERMINAL NUMBERING CONVENTION SHALL CONFORM TO JEDEC 95-1 SPP-012. DETAILS OF TERMINAL #1 IDENTIFIER ARE OPTIONAL, BUT MUST BE LOCATED WITHIN THE ZONE INDICATED. THE TERMINAL #1 IDENTIFIER MAY BE EITHER A MOLD OR MARKED FEATURE.
 5. DIMENSION b APPLIES TO METALLIZED TERMINAL AND IS MEASURED BETWEEN 0.25 mm AND 0.30 mm FROM TERMINAL TIP.
 6. ND AND NE REFER TO THE NUMBER OF TERMINALS ON EACH D AND E SIDE RESPECTIVELY.
 7. DEPOPULATION IS POSSIBLE IN A SYMMETRICAL FASHION.
 8. COPLANARITY APPLIES TO THE EXPOSED HEAT SINK SLUG AS WELL AS THE TERMINALS.
 9. DRAWING CONFORMS TO JEDEC MO220, EXCEPT FOR T2444-3, T2444-4 AND T2844-1.
 10. MARKING IS FOR PACKAGE ORIENTATION REFERENCE ONLY.
 11. COPLANARITY SHALL NOT EXCEED 0.08mm
 12. WARPAGE SHALL NOT EXCEED 0.10mm
 13. LEAD CENTERLINES TO BE AT TRUE POSITION AS DEFINED BY BASIC DIMENSION "e", ±0.05.
 14. NUMBER OF LEADS SHOWN ARE FOR REFERENCE ONLY.

-DRAWING NOT TO SCALE-

White LED 1x/1.5x Charge Pump in UCSP and Thin QFN

Package Information (continued)

(The package drawing(s) in this data sheet may not reflect the most current specifications. For the latest package outline information, go to www.maxim-ic.com/packages.

MAX1573

16LUCSP:EPS

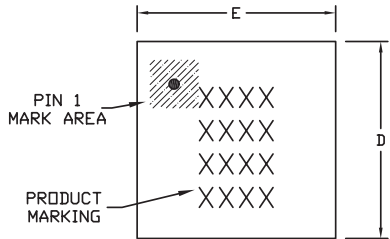

TOP VIEW

COMMON DIMENSIONS	
A	0.62±0.05-0.08
A1	0.29±0.02
A2	0.33 REF.
b	∅0.35±0.03
D1	1.50 BASIC
E1	1.50 BASIC
e	0.50 BASIC
SD	0.25 BASIC
SE	0.25 BASIC

PKG. CODE	VARIABLE DIMENSIONS		DEPOPULATED SOLDER BALLS
	D	E	
B16-1	2.02±0.05	2.02±0.05	NONE
B16-2	2.02±0.05	2.02±0.05	B3, C3
B16-3	2.02±0.05	2.02±0.05	B3, C2
B16-4	2.02±0.05	2.02±0.05	B2, C3
B16-5	2.02±0.05	2.02±0.05	B2, B3, C2, C3
B16-6	2.02±0.05	2.02±0.05	C3

NOTES:

1. ALL DIMENSIONS ARE IN MILLIMETERS.
2. PRODUCT MARKING: NUMBER OF CHARACTERS AND LINES VARY PER PRODUCT.

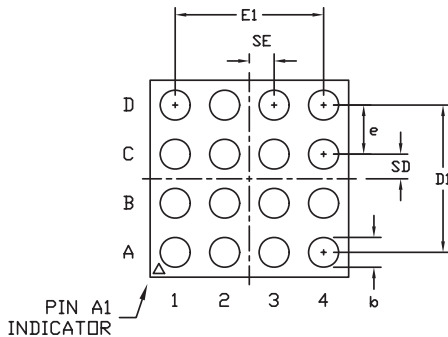

BOTTOM VIEW

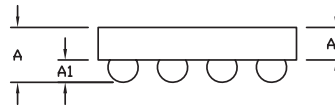

SIDE VIEW

DALLAS SEMICONDUCTOR		MAXIM	
PROPRIETARY INFORMATION			
TITLE: PACKAGE OUTLINE, 4x4 UCSP			
APPROVAL	DOCUMENT CONTROL NO. 21-0101	REV. H	1/1

Maxim cannot assume responsibility for use of any circuitry other than circuitry entirely embodied in a Maxim product. No circuit patent licenses are implied. Maxim reserves the right to change the circuitry and specifications without notice at any time.

Maxim Integrated Products, 120 San Gabriel Drive, Sunnyvale, CA 94086 408-737-7600 _____ 9

Looking for pricing, stock, or lifecycle information?

Click below to explore more details on WIN SOURCE:

 [View MAX1573ETE+T on WIN SOURCE](#)

 [Maxim Integrated Information](#)

Optimize Your Supply Chain with WIN SOURCE Solutions

-  Global Sourcing Solution
-  Obsolete Management
-  Cost Control Management
-  Shortage Management
-  Alternative Solution
-  Excess Inventory Management