



**THE DATASHEET OF
MAX1555EZK+T**



SOT23 Dual-Input USB/AC Adapter 1-Cell Li+ Battery Chargers

General Description

The MAX1551/MAX1555 charge a single-cell lithium-ion (Li+) battery from both USB and AC adapter sources. They operate with no external FETs or diodes, and accept operating input voltages up to 7V.

On-chip thermal limiting simplifies PC board layout and allows optimum charging rate without the thermal limits imposed by worst-case battery and input voltage. When the MAX1551/MAX1555 thermal limits are reached, the chargers do not shut down, but progressively reduce charging current.

The MAX1551 includes a $\overline{\text{POK}}$ output to indicate when input power is present. If either charging source is active, POK goes low. The MAX1555 instead features a CHG output to indicate charging status.

With USB connected, but without DC power, charge current is set to 100mA (max). This allows charging from both powered and unpowered USB hubs with no port communication required. When DC power is connected, charging current is set at 280mA (typ). No input-blocking diodes are required to prevent battery drain.

The MAX1551/MAX1555 are available in 5-pin thin SOT23 packages and operate over a -40°C to +85°C range.

Applications

- PDA's
- Wireless Appliances
- Cell Phones
- Digital Cameras

Pin Configuration

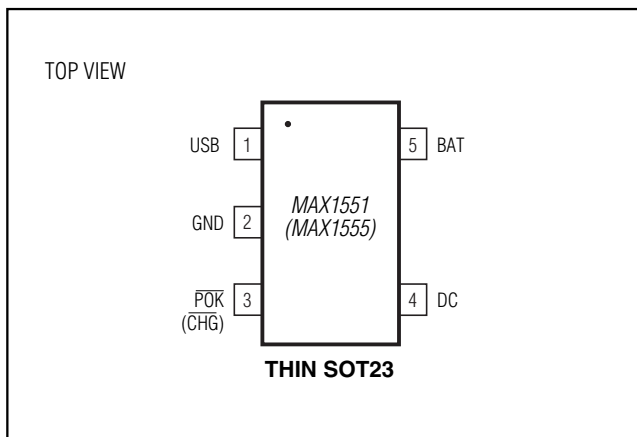

Features

- ◆ Charge from USB or AC Adapter
- ◆ Automatic Switchover when AC Adapter is Plugged In
- ◆ On-Chip Thermal Limiting Simplifies Board Design
- ◆ Charge Status Indicator
- ◆ 5-Pin Thin SOT23 Package

Ordering Information

PART	TEMP RANGE	PIN-PACKAGE
MAX1551EZK-T	-40°C to +85°C	5 Thin SOT23-5
MAX1555EZK-T	-40°C to +85°C	5 Thin SOT23-5

Selector Guide

PART	TOP MARK	FEATURES
MAX1551EZK	ADRT	$\overline{\text{POK}}$ Output
MAX1555EZK	ADRU	CHG Output

Typical Operating Circuit

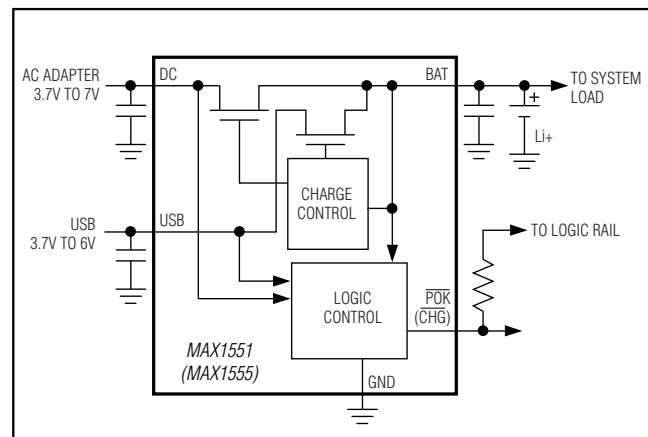

MAX1551/MAX1555

SOT23 Dual-Input USB/AC Adapter 1-Cell Li+ Battery Chargers

ABSOLUTE MAXIMUM RATINGS

DC to GND	0 to +8V	Operating Temperature Range	-40°C to +85°C
DC to BAT	0 to +7V	Junction Temperature Range	-40°C to +150°C
BAT, CHG, POK, USB to GND	-0.3V to +7V	Storage Temperature Range	-65°C to +150°C
Continuous Power Dissipation (T _A = +70°C)		Lead Temperature (soldering, 10s)	+300°C
5-Pin Thin SOT23 (derate 9.1mW/°C above +70°C)	727mW		

Stresses beyond those listed under "Absolute Maximum Ratings" may cause permanent damage to the device. These are stress ratings only, and functional operation of the device at these or any other conditions beyond those indicated in the operational sections of the specifications is not implied. Exposure to absolute maximum rating conditions for extended periods may affect device reliability.

ELECTRICAL CHARACTERISTICS

(V_{DC} = 5V, V_{USB} = 0, I_{BAT} = 0, C_{BAT} = 1μF, T_A = 0°C to +85°C, unless otherwise noted.)

PARAMETER	CONDITIONS	MIN	TYP	MAX	UNITS
DC					
DC Voltage Range	(Note 1)	3.7		7.0	V
DC to BAT Voltage Range		0.1		6.0	V
DC Undervoltage Lockout Threshold	Input rising, 430mV hysteresis, V _{BAT} = 3V (Note 1)	3.75	3.95	4.15	V
DC Supply Current			1.75	3	mA
DC to BAT On-Resistance	V _{DC} = 3.7V, V _{BAT} = 3.6V		1	2	Ω
DC to BAT Dropout Voltage	When charging stops, V _{BAT} = 4V, DC falling, 200mV hysteresis	30	60	90	mV
USB					
USB Voltage Range	(Note 1)	3.7		6.0	V
USB Undervoltage Threshold	Input rising, 430mV hysteresis, V _{DC} = 0, V _{BAT} = 3V (Note 1)	3.75	3.95	4.15	V
USB Supply Current	V _{USB} = 5V, V _{DC} = 0		1.65	3	mA
USB to BAT On-Resistance	V _{USB} = 3.7V, V _{BAT} = 3.6V, V _{DC} = 0		2	4	Ω
USB to BAT Dropout Voltage	When charging stops, V _{BAT} = 4V, USB falling, 200mV hysteresis, V _{DC} = 0	30	60	90	mV
BAT					
BAT Regulation Voltage	V _{DC} or V _{USB} = 5V	4.158	4.2	4.242	V
DC Charging Current	V _{BAT} = 3.3V, V _{USB} = 0, V _{DC} = 5V	220	280	340	mA
USB Charging Current	V _{BAT} = 3.3V, V _{DC} = 0, V _{USB} = 5V	80	90	100	mA
BAT Prequal Threshold	V _{BAT} rising, 100mV hysteresis	2.9	3	3.1	V
Prequalification Charging Current	V _{BAT} = 2.8V	20	40	80	mA
BAT Leakage Current	V _{DC} = V _{USB} = 0, V _{BAT} = 4.2V			5	μA
POK, CHG, AND THERMAL LIMIT					
CHG Threshold	Charge current where CHG goes high, I _{BAT} falling, 50mA hysteresis	25	50	100	mA
CHG, POK Logic-Low Output	I _{CHG} , I _{POK} = 10mA		150	300	mV
CHG, POK Leakage Current	V _{CHG} , V _{POK} = 6V, T _A = +25°C		0.001	1	μA
Thermal-Limit Temperature	Charge current reduced by 17mA/°C above this temperature		+110		°C

MAX1551/MAX1555

SOT23 Dual-Input USB/AC Adapter 1-Cell Li+ Battery Chargers

ELECTRICAL CHARACTERISTICS

($V_{DC} = 5V$, $V_{USB} = 0$, $I_{BAT} = 0$, $C_{BAT} = 1\mu F$, $T_A = -40^\circ C$ to $+85^\circ C$, unless otherwise noted.) (Note 2)

PARAMETER	CONDITIONS	MIN	MAX	UNITS
DC				
DC Voltage Range	(Note 1)	3.7	7.0	V
DC to BAT Voltage Range		0.1	6.0	V
DC Undervoltage Lockout Threshold	Input rising, 430mV hysteresis, $V_{BAT} = 3V$ (Note 1)	3.75	4.15	V
DC Supply Current			3	mA
DC to BAT On-Resistance	$V_{DC} = 3.7V$, $V_{BAT} = 3.6V$		2	Ω
DC to BAT Dropout Voltage	When charging stops, $V_{BAT} = 4V$, DC falling, 200mV hysteresis	30	95	mV
USB				
USB Voltage Range	(Note 1)	3.7	6.0	V
USB Undervoltage Lockout Threshold	Input rising, 430mV hysteresis, $V_{DC} = 0$, $V_{BAT} = 3V$ (Note 1)	3.75	4.15	V
USB Supply Current	$V_{USB} = 5V$, $V_{DC} = 0$		3	mA
USB to BAT On-Resistance	$V_{USB} = 3.7V$, $V_{BAT} = 3.6V$, $V_{DC} = 0$		4	Ω
USB to BAT Dropout Voltage	When charging stops, $V_{BAT} = 4V$, USB falling, 200mV hysteresis, $V_{DC} = 0$	30	95	mV
BAT				
BAT Regulation Voltage	V_{DC} or $V_{USB} = 5V$	4.141	4.259	V
DC Charging Current	$V_{BAT} = 3.3V$, $V_{USB} = 0$, $V_{DC} = 5V$	220	340	mA
USB Charging Current	$V_{BAT} = 3.3V$, $V_{DC} = 0$, $V_{USB} = 5V$	80	100	mA
BAT Prequal Threshold	V_{BAT} rising, 100mV hysteresis	2.9	3.1	V
Prequalification Charging Current	$V_{BAT} = 2.8V$	20	80	mA
BAT Leakage Current	$V_{DC} = V_{USB} = 0$, $V_{BAT} = 4.2V$		5	μA
POK, CHG				
\overline{CHG} Threshold	Charge current where \overline{CHG} goes high, I_{BAT} falling, 50mA hysteresis	25	100	mA
\overline{CHG} , \overline{POK} Logic-Low Output	$I_{\overline{CHG}}$, $I_{\overline{POK}} = 10mA$		300	mV
\overline{CHG} , \overline{POK} Leakage Current	$V_{\overline{CHG}}$, $V_{\overline{POK}} = 6V$, $T_A = +25^\circ C$		1	μA

Note 1: The input undervoltage lockout has 430mV of hysteresis. The charger turns on when an input rises to 3.95V (typ), and turns off when it falls below 3.52V.

Note 2: Specifications to $-40^\circ C$ are guaranteed by design, not production tested.

MAX1551/MAX1555

SOT23 Dual-Input USB/AC Adapter 1-Cell Li+ Battery Chargers

Typical Operating Characteristics

($V_{DC} = 5V$, $V_{USB} = 0$, $I_{BAT} = 0$, $C_{BAT} = 1\mu F$, $T_A = +25^\circ C$, unless otherwise noted.)

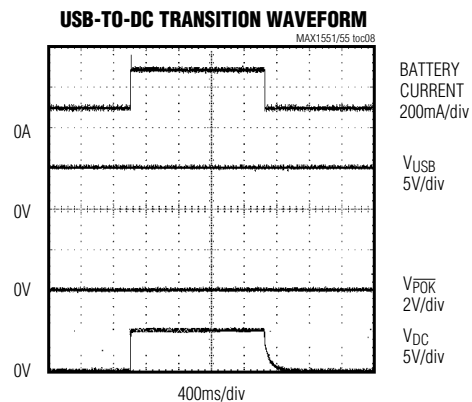
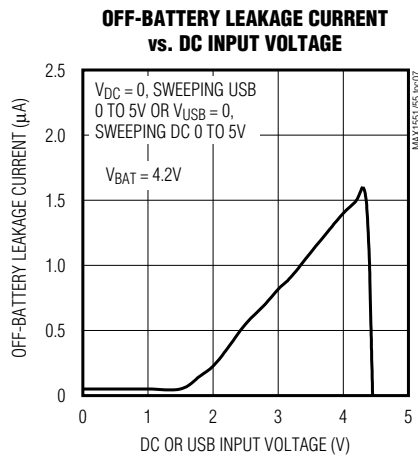
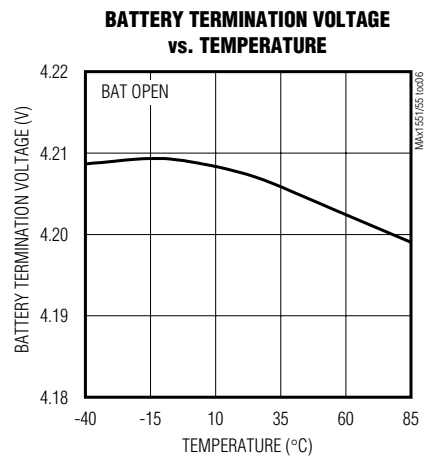
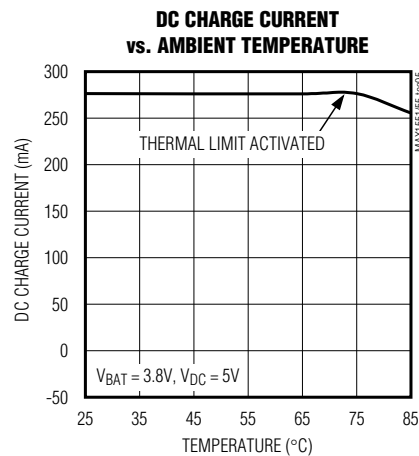
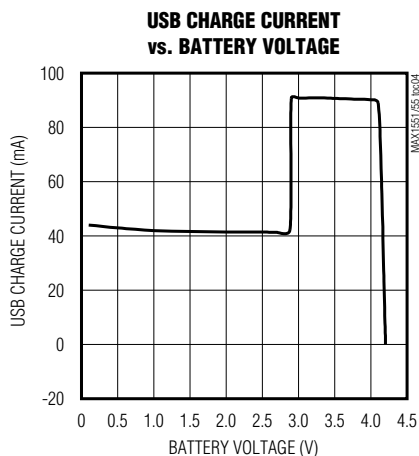
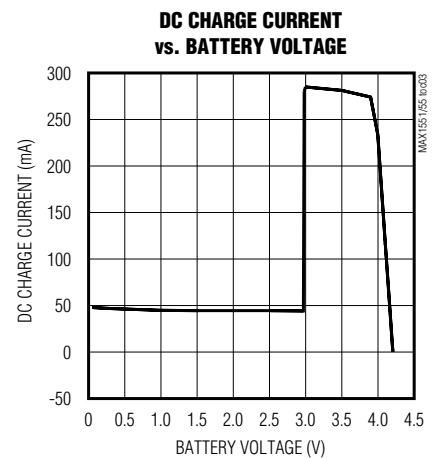
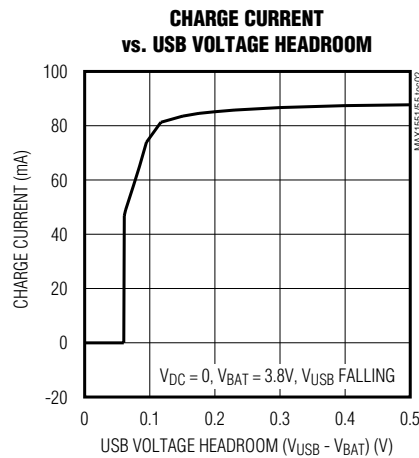
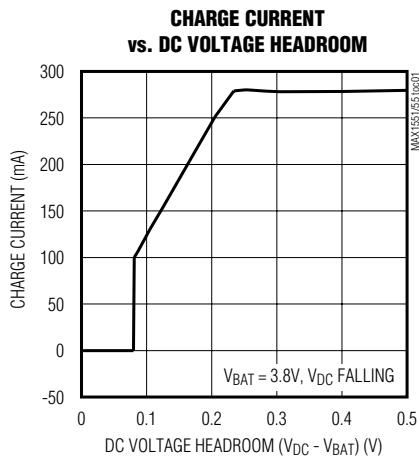

MAX1551/MAX1555

SOT23 Dual-Input USB/AC Adapter 1-Cell Li+ Battery Chargers

Pin Description

PIN	NAME	FUNCTION
1	USB	USB Port Charger Supply Input. USB draws up to 100mA to charge the battery. Decouple USB with a 1µF ceramic capacitor to GND.
2	GND	Ground
3	$\overline{\text{POK}}$	Power-OK Active-Low Open-Drain Charger Status Indicator. $\overline{\text{POK}}$ pulls low when either charger source is present (MAX1551 only).
	$\overline{\text{CHG}}$	Active-Low Open-Drain Charge Status Indicator. $\overline{\text{CHG}}$ pulls low when the battery is charging. $\overline{\text{CHG}}$ goes to a high-impedance state, indicating the battery is fully charged, when the charger is in voltage mode and charge current falls below 50mA. $\overline{\text{CHG}}$ is high impedance when both input sources are low (MAX1555 only).
4	DC	DC Charger Supply Input for an AC Adapter. DC draws 280mA to charge the battery. Decouple DC with a 1µF ceramic capacitor to GND.
5	BAT	Battery Connection. Decouple BAT with a 1µF ceramic capacitor to GND.

Detailed Description

The MAX1551/MAX1555 charge a single-cell Li+ battery from both USB and AC adapter sources, enabling portable users to forgo carrying a wall cube. These devices operate with no external FETs or diodes, and accept operating input voltages up to 7V.

An internal thermal control loop simplifies PC board layout and allows optimum charging rate without the thermal limits imposed by worst-case battery and input voltage. When the MAX1551/MAX1555 thermal limits are reached, the chargers do not shut down, but simply reduce charging current by 17mA/°C above a die temperature of +110°C.

With USB connected, but without DC power, the charge current is set to 100mA (max). This allows charging from both powered and unpowered USB hubs with no port communication required. When DC power is connected, charging current is set at 280mA (typ). The MAX1551/MAX1555 do not feature an enable input. Once power is connected to USB and/or DC, the charger is on.

When input power is removed, battery leakage current is less than 5µA. No input-blocking diodes are required to prevent battery drain. Insert a diode at DC (the adapter input) if protection from negative voltage inputs (reversed-polarity adapter plugs) is required.

Table 1. USB and DC Input Selection

$V_{\text{DC}} > 7\text{V}$ OR $V_{\text{USB}} > 6\text{V}$	$V_{\text{DC}} > 3.95\text{V}$ AND V_{USB} DON'T CARE	$V_{\text{DC}} < 3.52\text{V}$ AND $3.95\text{V} < V_{\text{USB}} < 6\text{V}$	V_{DC} AND $V_{\text{USB}} < 3.52\text{V}$
Exceeds operating input range. Not allowed. See the <i>Absolute Maximum Ratings</i> section.	280mA (typ) charging from DC	100mA (max) charging from USB	Undervoltage lockout

(V_{DC} takes precedence when both inputs are present.)

USB to Adapter Power Handoff

The MAX1551/MAX1555 can charge from either the USB input or the DC input. The battery does not charge from both sources at the same time. The MAX1551/MAX1555 automatically detect the active input and charge from that. If both power sources are active, the DC input takes precedence. The switchover between DC and USB is detailed in Table 1.

MAX1551 Power-OK ($\overline{\text{POK}}$)

The MAX1551's $\overline{\text{POK}}$ is an active-low, open-drain output that goes low when V_{DC} or V_{USB} is above 3.95V. $\overline{\text{POK}}$ can be used as a logic output or can drive an LED. $\overline{\text{POK}}$ indicates the charger is connected to input power and is charging.

MAX1555 Charge Status ($\overline{\text{CHG}}$)

The MAX1555's $\overline{\text{CHG}}$ is an active-low, open-drain charge status indicator. $\overline{\text{CHG}}$ pulls low when the battery is charging (whenever USB or DC are powered) and charge current is greater than 50mA. $\overline{\text{CHG}}$ indicates when the battery is fully charged by going high impedance when the charger is in voltage mode *and* charge current falls below 50mA. Charging does not stop when $\overline{\text{CHG}}$ goes high. $\overline{\text{CHG}}$ is low in precharge mode.

MAX1551/MAX1555

SOT23 Dual-Input USB/AC Adapter 1-Cell Li+ Battery Chargers

Precharge Current

The MAX1551/MAX1555 feature a precharge current to protect deeply discharged cells. If V_{BAT} is less than 3V, the device enters precharge mode where charging current is limited to 40mA.

Package Thermal Limiting

On-chip thermal limiting in the MAX1551/MAX1555 simplifies PC board layout and allows charging rates to be optimized without the limits imposed by worst-case battery and input voltages. The device reduces the power dissipation at BAT to prevent overheating. This allows the board design to be optimized for compact size and typical thermal conditions. When the MAX1551/MAX1555 thermal limits are reached, the chargers do

not shut down, but progressively reduce charging current by 17mA/°C above a die temperature of +110°C. Solder the MAX1551/MAX1555s' GND to a large ground plane to help dissipate power and keep the die temperature below the thermal limit. The USB charge current of 100mA is unlikely to induce thermal limiting.

Bypass Capacitors

Use ceramic bypass capacitors at DC, USB, and BAT. Mount these capacitors within 1cm of their respective pins. X7R and X5R dielectrics are recommended.

Chip Information

TRANSISTOR COUNT: 541

PROCESS: BiCMOS

Typical Application Circuit

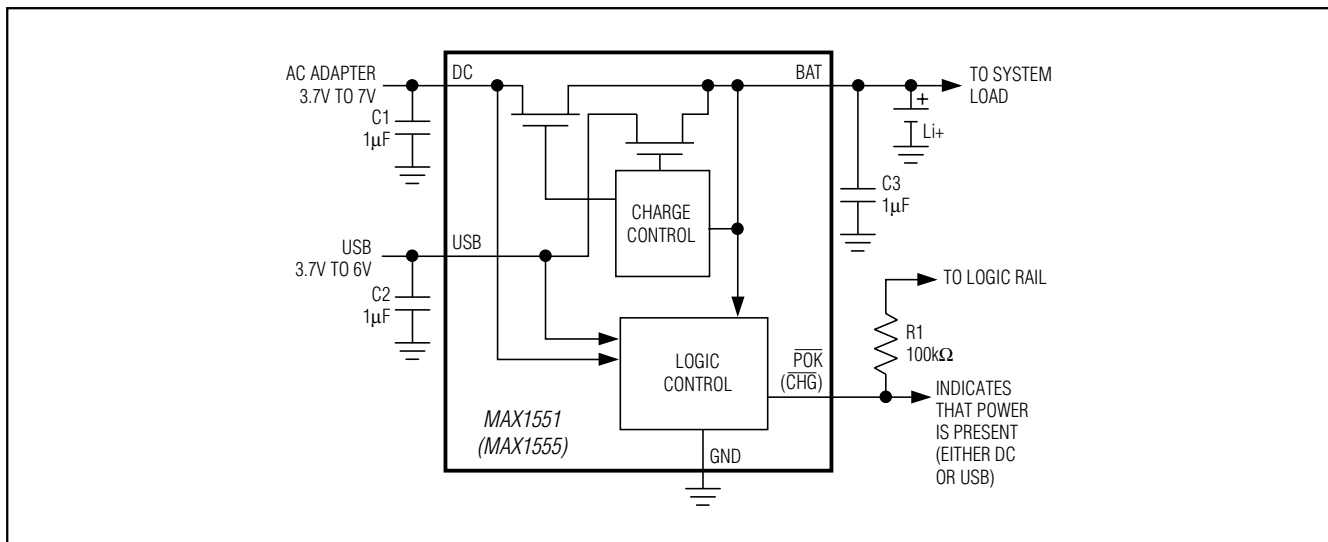

MAX1551/MAX1555

SOT23 Dual-Input USB/AC Adapter 1-Cell Li+ Battery Chargers

Package Information

(The package drawing(s) in this data sheet may not reflect the most current specifications. For the latest package outline information, go to www.maxim-integrated.com/packages.)

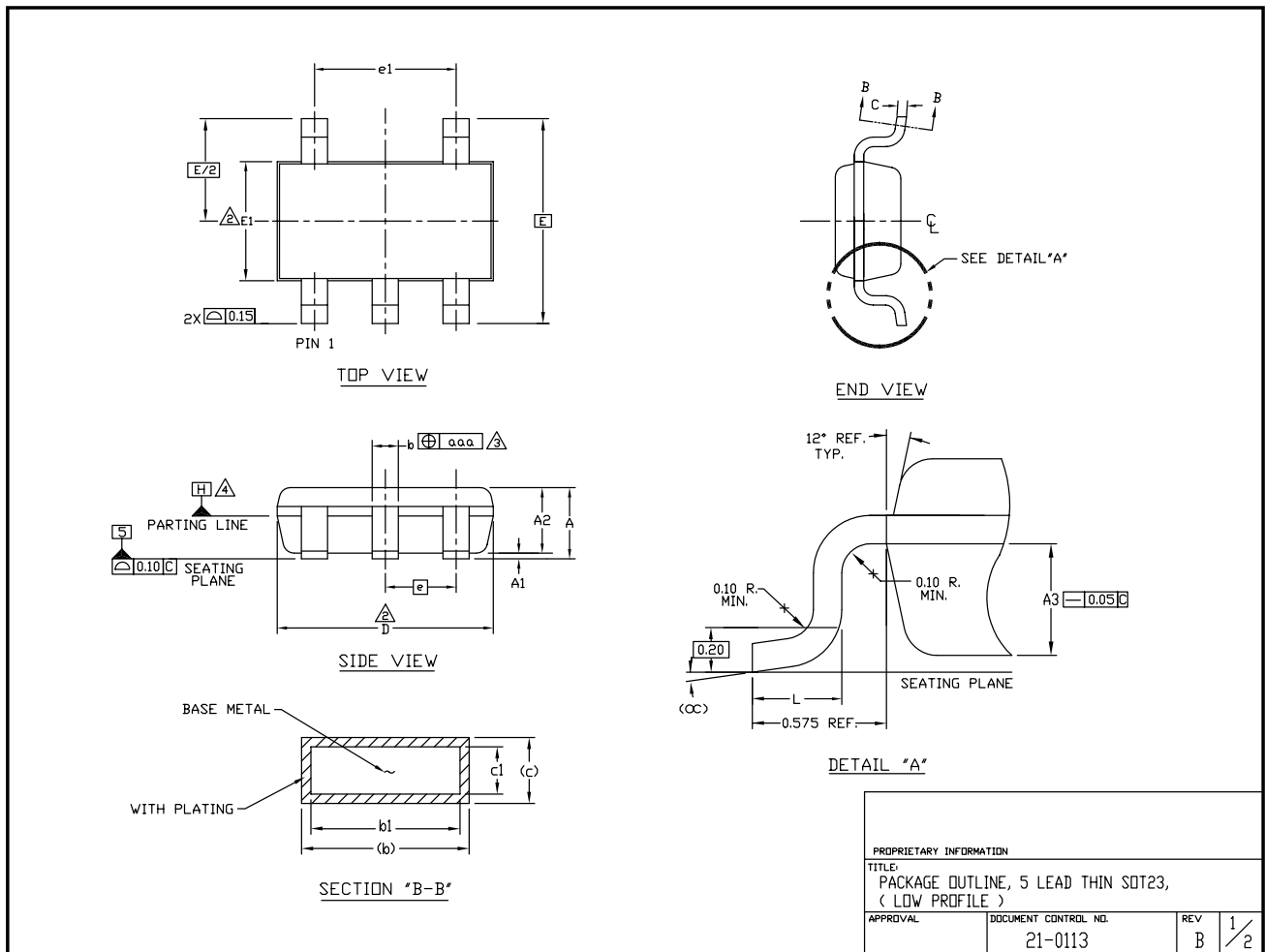

MAX1551/MAX1555

SOT23 Dual-Input USB/AC Adapter 1-Cell Li+ Battery Chargers

Package Information (continued)

(The package drawing(s) in this data sheet may not reflect the most current specifications. For the latest package outline information, go to www.maxim-ic.com/packages.)

NOTES:

1. ALL DIMENSIONS ARE IN MILLIMETERS.

2. "D" AND "E1" ARE REFERENCE DATUM AND DO NOT INCLUDE MOLD FLASH OR PROTRUSIONS, AND ARE MEASURED AT THE BOTTOM PARTING LINE. MOLD FLASH OR PROTRUSION SHALL NOT EXCEED 0.15mm ON "D" AND 0.25mm ON "E" PER SIDE.

3. THE LEAD WIDTH DIMENSION DOES NOT INCLUDE DAMBAR PROTRUSION. ALLOWABLE DAMBAR PROTRUSION SHALL BE 0.07mm TOTAL IN EXCESS OF THE LEAD WIDTH DIMENSION AT MAXIMUM MATERIAL CONDITION.

4. DATUM PLANE "H" LOCATED AT MOLD PARTING LINE AND COINCIDENT WITH LEAD, WHERE LEAD EXITS PLASTIC BODY AT THE BOTTOM OF PARTING LINE.

5. THE LEAD TIPS MUST LINE WITHIN A SPECIFIED TOLERANCE ZONE. THIS TOLERANCE ZONE IS DEFINED BY TWO PARALLEL LINES. ONE PLANE IS THE SEATING PLANE, DATUM [-C-]; AND THE OTHER PLANE IS AT THE SPECIFIED DISTANCE FROM [-C-] IN THE DIRECTION INDICATED. FORMED LEADS SHALL BE PLANAR WITH RESPECT TO ONE ANOTHER WITH 0.10mm AT SEATING PLANE.

6. THIS PART IS COMPLIANT WITH JEDEC SPECIFICATION MO-193 EXCEPT FOR THE "e" DIMENSION WHICH IS 0.95mm INSTEAD OF 1.00mm. THIS PART IS IN FULL COMPLIANCE TO EIAJ SPECIFICATION SC-74.

SYMBOLS			
	MIN	NOM	MAX
A	-	-	1.10
A1	0.05	0.075	0.10
A2	0.85	0.88	0.90
A3	0.50 BSC		
b	0.30	-	0.45
b1	0.25	0.35	0.40
c	0.15	-	0.20
c1	0.12	0.127	0.15
D	2.80	2.90	3.00
E	2.75 BSC		
E1	1.55	1.60	1.65
L	0.30	0.40	0.50
e1	1.90 BSC		
e	0.95 BSC		
CC	0°	4°	8°
aaa	0.20		

PROPRIETARY INFORMATION			
TITLE: PACKAGE OUTLINE, 5 LEAD THIN SOT23, (LOW PROFILE)			
APPROVAL	DOCUMENT CONTROL NO.	REV	2/2
	21-0113	B	



Maxim cannot assume responsibility for use of any circuitry other than circuitry entirely embodied in a Maxim product. No circuit patent licenses are implied. Maxim reserves the right to change the circuitry and specifications without notice at any time. The parametric values (min and max limits) shown in the Electrical Characteristics table are guaranteed. Other parametric values quoted in this data sheet are provided for guidance.

8 **Maxim Integrated 160 Rio Robles, San Jose, CA 95134 USA 1-408-601-1000**

Looking for pricing, stock, or lifecycle information?

Click below to explore more details on WIN SOURCE:

- ⊖ [View MAX1555EZK+T on WIN SOURCE](#)
- ⊖ [Maxim Integrated Information](#)

Optimize Your Supply Chain with WIN SOURCE Solutions

- ✓ Global Sourcing Solution
- ✓ Obsolete Management
- ✓ Cost Control Management
- ✓ Shortage Management
- ✓ Alternative Solution
- ✓ Excess Inventory Management