



**THE DATASHEET OF  
MAX153CWP+T**



# MAX153

# 1MSPS, $\mu$ P-Compatible, 8-Bit ADC with 1 $\mu$ A Power-Down

## General Description

The MAX153 high-speed, microprocessor ( $\mu$ P)-compatible, 8-bit analog-to-digital converter (ADC) uses a half-flash technique to achieve a 660ns conversion time, and digitizes at a rate of 1M samples per second (MSPS). It operates with single +5V or dual  $\pm$ 5V supplies and accepts either unipolar or bipolar inputs. A  $\overline{\text{POWERDN}}$  (power-down) pin reduces current consumption to a typical value of 1 $\mu$ A (with 5V supply). The part returns from power-down to normal operating mode in less than 200ns, providing large reductions in supply current in applications with burst-mode input signals.

The MAX153 is DC and dynamically tested. Its  $\mu$ P interface appears as a memory location or input/output port that requires no external interface logic. The data outputs use latched, three-state buffered circuitry for direct connection to a  $\mu$ P data bus or system input port. The ADC's input/reference arrangement enables ratiometric operation.

## Applications

- Cellular Telephones
- Portable Radios
- Battery-Powered Systems
- Burst-Mode Data Acquisition
- Digital-Signal Processing
- Telecommunications
- High-Speed Servo Loops

**Ordering Information** appears at end of data sheet.

For related parts and recommended products to use with this part, refer to [www.maximintegrated.com/MAX153.related](http://www.maximintegrated.com/MAX153.related).

## Features

- 660ns Conversion Time
- Power-Up/Power-Down in 200ns
- Internal Track/Hold
- 1MSPS Throughput
- Low Power  
40mW (Operating Mode)  
5 $\mu$ W (Power-Down Mode)
- 1MHz Full-Power Bandwidth
- 20-Pin Narrow DIP, SO, and SSOP Packages
- No External Clock Required
- Unipolar/Bipolar Inputs
- Single +5V or Dual  $\pm$ 5V Supplies
- Ratiometric Reference Inputs

## Functional Diagram

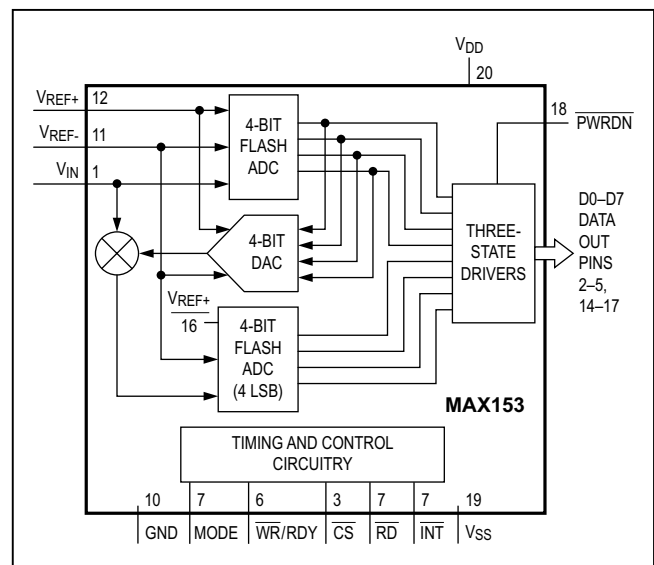

**Absolute Maximum Ratings**

(All voltages referenced to GND.)

|   |  |
|---|--|
| V <sub>DD</sub> .....   | -0.3V to +7V   |
| V <sub>SS</sub> .....   | +0.3V to -7V   |
| Digital Input Voltage .....                                   | +0.3V to (V <sub>DD</sub> + 0.3V)                    |
| Digital Output Voltage.....                                   | -0.3V to (V <sub>DD</sub> + 0.3V)                    |
| V <sub>REF+</sub> , V <sub>REF-</sub> , V <sub>IN</sub> ..... | (V <sub>SS</sub> - 0.3V) to (V <sub>DD</sub> + 0.3V) |
| Continuous Power Dissipation (T <sub>A</sub> = +70°C)         |  |
| PDIP (derate 11.11mW/°C above + 70°C) .....                   | 889mW  |

|  |                 |
|--|-----------------|
| SO(W) (derate 10.00mW/°C above +70°C)..... | 800mW           |
| SSOP (derate 8.00mW/°C above +70°C) .....  | 640mW           |
| Operating Temperature Ranges               |                 |
| MAX153C .....                              | 0 to +70°C      |
| MAX153E .....                              | -40°C to +85°C  |
| Storage Temperature Range .....            | -65°C to +150°C |
| Lead Temperature (soldering, 10s) .....    | +300°C          |
| Soldering Temperature (reflow) .....       | +260°C          |

Stresses beyond those listed under "Absolute Maximum Ratings" may cause permanent damage to the device. These are stress ratings only, and functional operation of the device at these or any other conditions beyond those indicated in the operational sections of the specifications is not implied. Exposure to absolute maximum rating conditions for extended periods may affect device reliability.

**Electrical Characteristics**

(V<sub>DD</sub> = +5V  $\pm$ 5%, V<sub>GND</sub> = 0V; Unipolar Input Range: V<sub>SS</sub> = GND, V<sub>REF+</sub> = 5V, V<sub>REF-</sub> = GND; Bipolar Input Range: V<sub>SS</sub> = -5V  $\pm$ 5%, V<sub>REF+</sub> = 2.5V, V<sub>REF-</sub> = -2.5V; 100% production tested, specifications are given for RD Mode (MODE = GND), T<sub>A</sub> = T<sub>MIN</sub> to T<sub>MAX</sub>, unless otherwise noted.)

| PARAMETER                              | SYMBOL           | CONDITIONS  | MIN               | TYP | MAX               | UNITS      |
|--|------------------|---|-------------------|-----|-------------------|------------|
| <b>ACCURACY</b>                        |                  |   |                   |     |                   |            |
| Resolution                             | N                |   | 8                 |     |                   | Bits       |
| Total Unadjusted Error                 | TUE              | Unipolar range  |                   |     | $\pm$ 1           | LSB        |
| Differential Nonlinearity              | DNL              | No missing codes guaranteed   |                   |     | $\pm$ 1           | LSB        |
| Zero-Code Error                        |                  | Bipolar input range   |                   |     | $\pm$ 1           | LSB        |
| Full-Scale Error                       |                  | Bipolar input range   |                   |     | $\pm$ 1           | LSB        |
| <b>DYNAMIC SPECIFICATIONS (Note 1)</b> |                  |   |                   |     |                   |            |
| Signal-to-Noise Plus Distortion Noise  | SINAD            | f <sub>SAMPLE</sub> = 1MHz, f <sub>IN</sub> = 195.8kHz                              | 45                |     |                   | dB         |
| Total Harmonic Distortion              | THD              | f <sub>SAMPLE</sub> = 1MHz, f <sub>IN</sub> = 195.8kHz                              |                   |     | -50               | dB         |
| Peak Harmonic or Spurious Noise        |                  | f <sub>SAMPLE</sub> = 1MHz, f <sub>IN</sub> = 195.8kHz                              |                   |     | -50               | dB         |
| Conversion Time (WR-RD Mode) (Note 2)  | t <sub>CWR</sub> | T <sub>A</sub> = +25°C, t <sub>RD</sub> < t <sub>INTL</sub> , C <sub>L</sub> = 20pF |                   |     | 660               | ns         |
| Conversion Time (RD Mode)              | t <sub>CRD</sub> | T <sub>A</sub> = +25°C  |                   |     | 700               | ns         |
|  |                  | T <sub>A</sub> = T <sub>MIN</sub> to T <sub>MAX</sub>                               |                   |     | 875               |            |
| Full-Power Bandwidth                   |                  | V <sub>IN</sub> = 5V <sub>P-P</sub>   |                   | 1   |                   | MHz        |
| Input Slew Rate                        |                  |   | 3.14              | 15  |                   | V/ $\mu$ s |
| <b>ANALOG INPUT</b>                    |                  |   |                   |     |                   |            |
| Input Voltage Range                    | V <sub>IN</sub>  |   | V <sub>REF-</sub> |     | V <sub>REF+</sub> | V          |
| Input Leakage Current                  | I <sub>IN</sub>  | -5V $\leq$ V <sub>IN</sub> $\leq$ +5V   |                   |     | $\pm$ 3           | $\mu$ A    |
| Input Capacitance                      | C <sub>IN</sub>  |   |                   | 22  |                   | pF         |
| <b>REFERENCE INPUT</b>                 |                  |   |                   |     |                   |            |
| Reference Resistance                   | R <sub>REF</sub> |   | 1                 | 2   | 4                 | k $\Omega$ |
| V <sub>REF+</sub> Input Voltage Range  |                  |   | V <sub>REF-</sub> |     | V <sub>DD</sub>   | V          |
| V <sub>REF-</sub> Input Voltage Range  |                  |   | V <sub>SS</sub>   |     | V <sub>REF+</sub> | V          |

## Electrical Characteristics (continued)

( $V_{DD} = +5V \pm 5\%$ ,  $V_{GND} = 0V$ ; Unipolar Input Range:  $V_{SS} = GND$ ,  $V_{REF+} = 5V$ ,  $V_{REF-} = GND$ ; Bipolar Input Range:  $V_{SS} = -5V \pm 5\%$ ,  $V_{REF+} = 2.5V$ ,  $V_{REF-} = -2.5V$ ; 100% production tested, specifications are given for RD Mode (MODE = GND),  $T_A = T_{MIN}$  to  $T_{MAX}$ , unless otherwise noted.)

| PARAMETER                                    | SYMBOL    | CONDITIONS  | MIN     | TYP        | MAX       | UNITS   |
|--|-----------|---|---------|------------|-----------|---------|
| <b>LOGIC INPUTS</b>                          |           |   |         |            |           |         |
| Input High Voltage                           | $V_{INH}$ | $\overline{CS}$ , $\overline{WR}$ , $\overline{RD}$ , $\overline{PWRDN}$            | 2.4     |            |           | V       |
|  |           | MODE  | 3.5     |            |           |         |
| Input Low Voltage                            | $V_{INL}$ | $\overline{CS}$ , $\overline{WR}$ , $\overline{RD}$ , $\overline{PWRDN}$            |         |            | 0.8       | V       |
|  |           | MODE  |         |            | 1.5       |         |
| Input High Current                           | $I_{INH}$ | $\overline{CS}$ , $\overline{RD}$ , $\overline{PWRDN}$                              |         |            | 1         | $\mu$ A |
|  |           | $\overline{WR}$   |         |            | 3         |         |
|  |           | MODE  |         | 50         | 200       |         |
| Input Low Current                            | $I_{INL}$ | $\overline{CS}$ , $\overline{WR}$ , $\overline{RD}$ , $\overline{PWRDN}$            |         |            | $\pm 1$   | $\mu$ A |
| Input Capacitance (Note 3)                   | $C_{IN}$  | $\overline{CS}$ , $\overline{WR}$ , $\overline{RD}$ , $\overline{PWRDN}$ , MODE     |         | 5          | 8         | pF      |
| <b>LOGIC OUTPUTS</b>                         |           |   |         |            |           |         |
| Output Low Voltage                           | $V_{OL}$  | $I_{SINK} = 1.6mA$ , $\overline{INT}$ , D0–D7                                       |         |            | 0.4       | V       |
|  |           | RDY, $I_{SINK} = 2.6mA$   |         |            | 0.4       |         |
| Output High Voltage                          | $V_{OH}$  | $I_{SOURCE} = 360\mu A$ , $\overline{INT}$ , D0–D7                                  | 4       |            |           | V       |
| Floating State Current                       | $I_{LKG}$ | D0–D7, RDY  |         |            | $\pm 3$   | $\mu$ A |
| Floating Capacitance (Note 3)                | $C_{OUT}$ | D7–D0, RDY  |         | 5          | 8         | pF      |
| <b>POWER REQUIREMENTS</b>                    |           |   |         |            |           |         |
| Positive Supply Voltage                      | $V_{DD}$  | $\pm 5\%$ for specified accuracy  |         | 5          |           | V       |
| Negative Supply Voltage (Unipolar Operation) | $V_{SS}$  |   |         | GND        |           | V       |
| Negative Supply Voltage (Bipolar Operation)  | $V_{SS}$  | $\pm 5\%$ for specified accuracy  |         | -5         |           | V       |
| $V_{DD}$ Supply Current                      | $I_{DD}$  | $V_{\overline{CS}} = V_{\overline{RD}} = 0V$ ,<br>$V_{\overline{PWRDN}} = 5V$       | MAX153C | 8          | 15        | mA      |
|  |           |   | MAX153E | 8          | 20        |         |
| Power-Down VDD Current                       |           | $V_{\overline{CS}} = V_{\overline{RD}} = 5V$ , $V_{\overline{PWRDN}} = 0V$ (Note 4) |         | 1          | 100       | $\mu$ A |
| $V_{SS}$ Supply Current                      | $I_{SS}$  | $V_{\overline{CS}} = V_{\overline{RD}} = 0V$ , $V_{\overline{PWRDN}} = 5V$          |         | 25         | 100       | $\mu$ A |
| Power-Down $V_{SS}$ Current                  |           | $V_{\overline{CS}} = V_{\overline{RD}} = 5V$ , $V_{\overline{PWRDN}} = 0V$          |         | 12         | 100       | $\mu$ A |
| Power-Supply Rejection                       | PSR       | $V_{DD} = 4.75V$ to $5.25V$ , $V_{REF+} = 4.75V$ (max), unipolar mode               |         | $\pm 1/16$ | $\pm 1/4$ | LSB     |

**Note 1:** Bipolar input range,  $V_{IN} = \pm 2.5V_{P-P}$ . WR-RD mode.

**Note 2:** See Figure 1 for load circuit. Parameter defined as the time required for the output to cross +0.8V or +2.4V.

**Note 3:** Guaranteed by design.

**Note 4:** Tested with  $\overline{CS}$ ,  $\overline{RD}$ ,  $\overline{PWRDN}$  at CMOS logic levels. Power-down current increases to several hundred)  $\mu$ A at TTL levels.

**TIMING CHARACTERISTICS (Note 5)**

( $V_{DD} = +5V \pm 5\%$ ,  $V_{SS} = 0V$  for Unipolar Input Range,  $V_{SS} = -5V \pm 5\%$  for Bipolar Input Range, 100% production tested,  $T_A = +25^\circ C$ , unless otherwise noted.)

| PARAMETER   | SYMBOL      | CONDITIONS  | MIN   | TYP | MAX            | UNITS   |
|---|-------------|---|-------|-----|----------------|---------|
| $\overline{CS}$ TO $\overline{RD}/\overline{WR}$ Setup Time                           | $t_{CSS}$   |   | 0     |     |                | ns      |
| $\overline{CS}$ to $\overline{RD}/\overline{WR}$ Hold Time                            | $t_{CSH}$   |   | 0     |     |                | ns      |
| $\overline{CS}$ to $\overline{RDY}$ Delay (Note 6)                                    | $t_{RDY}$   | $C_L = 50pF$  |       |     | 70             | ns      |
|   |             | $T_A = T_{MIN}$ to $T_{MAX}$ , $C_L = 50pF$             |       |     | 85             |         |
| Data-Access Time (RD Mode) (Note 2)   | $t_{ACC0}$  | $C_L = 20pF$  |       |     | $t_{CRD} + 25$ | ns      |
|   |             | $T_A = T_{MIN}$ to $T_{MAX}$ , $C_L = 20pF$             |       |     | $t_{CRD} + 30$ |         |
|   |             | $C_L = 100pF$   |       |     | $t_{CRD} + 50$ |         |
|   |             | $T_A = T_{MIN}$ to $T_{MAX}$ , $C_L = 100pF$            |       |     | $t_{CRD} + 65$ |         |
| $\overline{RD}$ to $\overline{INT}$ Delay (RD Mode)                                   | $t_{INTH}$  | $C_L = 50pF$  |       | 50  | 80             | ns      |
|   |             | $T_A = T_{MIN}$ to $T_{MAX}$ , $C_L = 50pF$             |       |     |                |         |
| Data-Hold Time (Note 7)   | $t_{DH}$    |   |       |     | 60             | ns      |
|   |             | $T_A = T_{MIN}$ to $T_{MAX}$                            |       |     |                |         |
| Delay Time Between Conversions (Acquisition Time)                                     | $t_p$       |   | 160   |     |                | ns      |
|   |             | $T_A = T_{MIN}$ to $T_{MAX}$                            | 185   |     |                |         |
| Write Pulse Width   | $t_{WR}$    |   | 0.250 |     | 10             | $\mu s$ |
|   |             | $T_A = T_{MIN}$ to $T_{MAX}$                            | 0.280 |     | 10             |         |
| Delay Time Between $\overline{WR}$ and $\overline{RD}$ Pulses                         | $t_{RD}$    |   | 250   |     |                | ns      |
|   |             | $T_A = T_{MIN}$ to $T_{MAX}$                            | 350   |     |                |         |
| RD Pulse Width ( $\overline{WR}$ - $\overline{RD}$ Mode) Determined by $t_{ACC1}$     | $t_{READ1}$ | Figure 6  | 160   |     |                | ns      |
|   |             | $T_A = T_{MIN}$ to $T_{MAX}$ , Figure 6                 | 205   |     |                |         |
| Data-Access Time (WR-RD Mode) (Note 2) $t_{RD} < t_{INL}$                             | $t_{ACC1}$  | $C_L = 20pF$ , Figure 6                                 |       |     | 160            | ns      |
|   |             | $T_A = T_{MIN}$ to $T_{MAX}$ , $C_L = 20pF$ , Figure 6  |       |     | 205            |         |
|   |             | $C_L = 100pF$ , Figure 6                                |       |     | 185            |         |
|   |             | $T_A = T_{MIN}$ to $T_{MAX}$ , $C_L = 100pF$ , Figure 6 |       |     | 235            |         |
| $\overline{RD}$ to $\overline{INT}$ Delay   | $t_{RI}$    |   |       |     | 150            | ns      |
|   |             | $T_A = T_{MIN}$ to $T_{MAX}$                            |       |     |                |         |
| $\overline{WR}$ to $\overline{INT}$ Delay   | $t_{INTL}$  | $C_L = 50pF$  |       | 380 | 500            | ns      |
|   |             | $T_A = T_{MIN}$ to $T_{MAX}$ , $C_L = 50pF$             |       |     |                |         |
| $\overline{RD}$ Pulse Width (WR-RD Mode) Determined by $t_{ACC2}$ $t_{RD} > t_{INTL}$ | $t_{READ2}$ | Figure 5  | 65    |     |                | ns      |
|   |             | $T_A = T_{MIN}$ to $T_{MAX}$ , Figure 5                 | 75    |     |                |         |
| Data-Access Time (WR-RD Mode) (Note 2) $t_{RD} > t_{INTL}$                            | $t_{ACC2}$  | $C_L = 20pF$ , Figure 5                                 |       |     | 65             | ns      |
|   |             | $T_A = T_{MIN}$ to $T_{MAX}$ , $C_L = 20pF$ , Figure 5  |       |     | 75             |         |
|   |             | $C_L = 100pF$ , Figure 5                                |       |     | 90             |         |
|   |             | $T_A = T_{MIN}$ to $T_{MAX}$ , $C_L = 100pF$ , Figure 5 |       |     | 110            |         |

**TIMING CHARACTERISTICS (Note 5) (continued)**

( $V_{DD} = +5V \pm 5\%$ ,  $V_{SS} = 0V$  for Unipolar Input Range,  $V_{SS} = -5V \pm 5\%$  for Bipolar Input Range, 100% production tested,  $T_A = +25^\circ C$ , unless otherwise noted.)

| PARAMETER  | SYMBOL     | CONDITIONS                                   | MIN | TYP | MAX | UNITS |
|--|------------|--|-----|-----|-----|-------|
| $\overline{WR}$ to $\overline{INT}$ Delay (Pipelined Mode) | $t_{IHWR}$ | $C_L = 50pF$                                 |     |     | 80  | ns    |
|  |            | $T_A = T_{MIN}$ to $T_{MAX}$ , $C_L = 50pF$  |     |     | 100 |       |
| Data-Access Time After $\overline{INT}$ (Note 2)           | $t_{ID}$   | $C_L = 20pF$                                 |     |     | 30  | ns    |
|  |            | $T_A = T_{MIN}$ to $T_{MAX}$ , $C_L = 20pF$  |     |     | 35  |       |
|  |            | $C_L = 100pF$                                |     |     | 45  |       |
|  |            | $T_A = T_{MIN}$ to $T_{MAX}$ , $C_L = 100pF$ |     |     | 60  |       |

**Note 5:** Input control signals are specified with  $t_r = t_f = 5ns$ , 10% to 90% of +5V and timed from a 1.6V voltage level.

**Note 6:**  $R_L = 5.1k\Omega$  pullup resistor.

**Note 7:** See Figure 2 for load circuit. Parameter defined as the time required for data lines to change 0.5V.

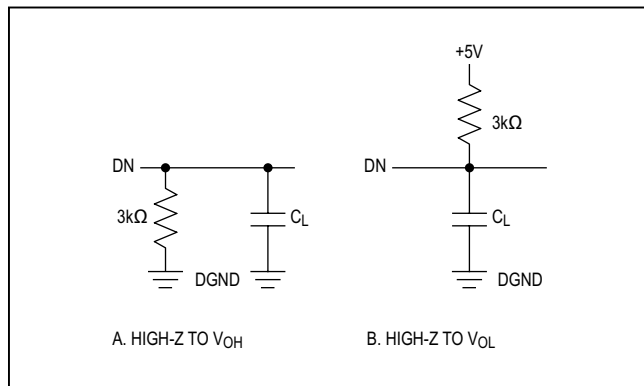

Figure 1. Load Circuits for Data-Access Time Test

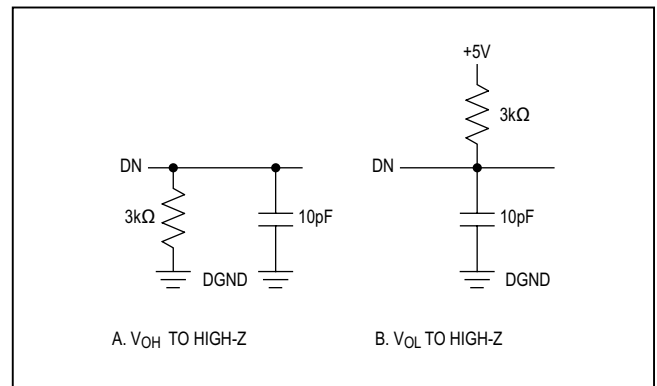
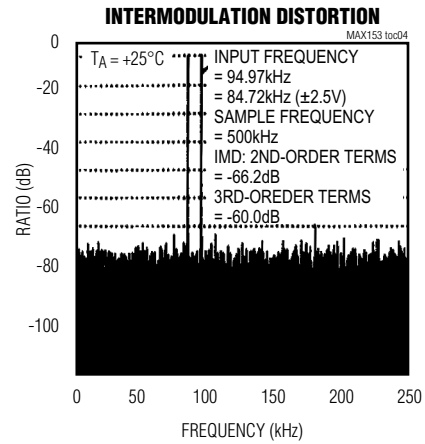
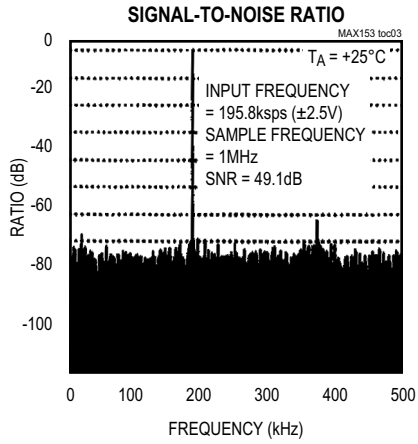
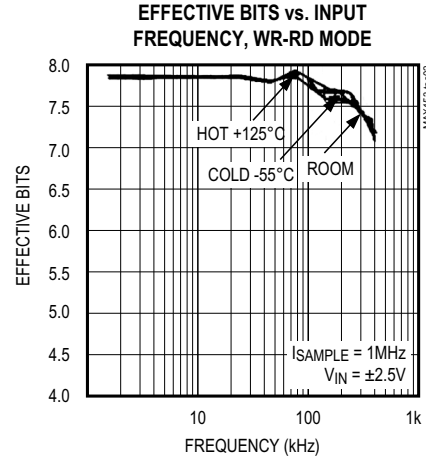
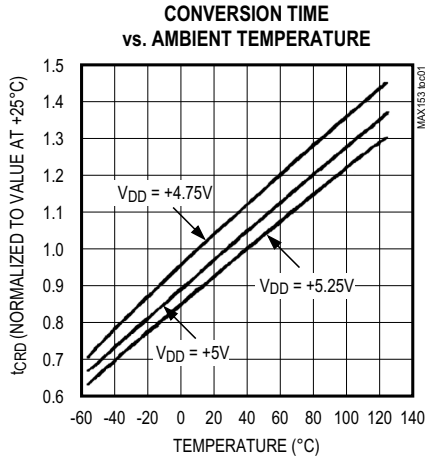
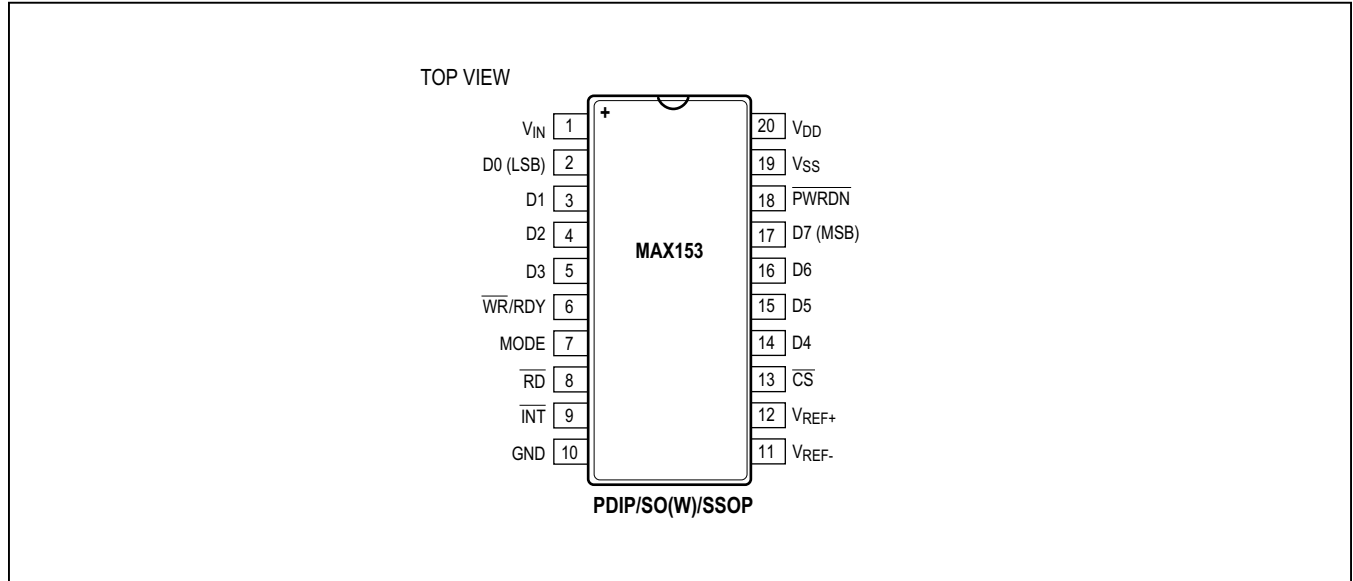

Figure 2. Load Circuits for Data-Hold Time Test

Typical Operating Characteristics



Pin Configuration



Pin Description

| PIN   | NAME              | FUNCTION  |
|-------|-------------------|---|
| 1     | V <sub>IN</sub>   | Analog Input. Range is V <sub>REF-</sub> > V <sub>IN</sub> < V <sub>REF+</sub> .  |
| 2     | D0                | Three-State Data Output (LSB)   |
| 3–5   | D1–D3             | Three-State Data Outputs  |
| 6     | WR/RDY            | WRITE Control Input/READY Status Output*  |
| 7     | MODE              | MODE Selection Input. Internally pulled low with a 50 $\mu$ A current source.<br>MODE = 0 activates read mode.<br>MODE = 1 activates write-read mode* |
| 8     | RD                | READ Input. Must be low to access data*.  |
| 9     | INT               | INTERRUPT Output goes low to indicate end of conversion*.   |
| 10    | GND               | Ground  |
| 11    | V <sub>REF-</sub> | Lower Limit of Reference Span. Sets the zero-code voltage. Range is V <sub>SS</sub> < V <sub>REF-</sub> < V <sub>REF+</sub> .                         |
| 12    | V <sub>REF+</sub> | Upper Limit to Reference Span. Sets the full-scale input voltage. Range is V <sub>REF-</sub> < V <sub>REF+</sub> < V <sub>DD</sub> .                  |
| 13    | CS                | CHIP SELECT Input. Must be low for the device to recognize WR or RD inputs.   |
| 14–16 | D4–D6             | Three-State Data Outputs  |
| 17    | D7                | Three-State Data Output (MSB)   |
| 18    | PWRDN             | POWERDOWN Input. Reduces supply current when low. CS must be high during power-down.  |
| 19    | V <sub>SS</sub>   | Negative Supply. Unipolar: V <sub>SS</sub> = 0V, Bipolar: V <sub>SS</sub> = -5V.  |
| 20    | V <sub>DD</sub>   | Positive Supply, +5V  |

\*See the Digital Interface section.

## Detailed Description

### Converter Operation

The MAX153 uses a half-flash conversion technique (see the *Functional Diagram*) in which two 4-bit flash ADC sections achieve an 8-bit result. Using 15 comparators, the flash ADC compares the unknown input voltage to the reference ladder and provides the upper 4 data bits.

An internal digital-to-analog converter (DAC) uses the 4 most significant bits (MSBs) to generate the analog result from the first flash conversion and a residue voltage that is the difference between the unknown input and the DAC voltage. The residue is then compared again with the flash comparators to obtain the lower 4 data bits (LSBs).

### Power-Down Mode

In burst-mode or low sample-rate applications, the MAX153 can be shut down between conversions, reducing supply current to microamp levels. A TTL/CMOS logic-low on the  $\overline{\text{PWRDN}}$  pin shuts the device down, reducing supply current to typically 1 $\mu$ A when powered from a single 5V supply.  $\overline{\text{CS}}$  must be high when power-down is used. A logic-high on  $\overline{\text{PWRDN}}$  wakes up the MAX153. A new conversion can be started ( $\overline{\text{WR}}$  asserted low) within 360ns of the  $\overline{\text{PWRDN}}$  pin being driven high 200ns to power up plus 160ns for track/hold acquisition). If power-down mode is not required, connect  $\overline{\text{PWRDN}}$  to  $V_{\text{DD}}$ .

Once the MAX153 is in power-down mode, lowest supply current is drawn with MODE low (RD mode) due to an internal 50 $\mu$ A pulldown resistor at this pin.  $\overline{\text{CS}}$  must remain high during shutdown because the MAX153 may attempt to start a conversion that it cannot complete. In addition, for minimum current consumption, other digital inputs should remain stable in power-down. RDY, an open-drain output (in RD mode), will then fall and remain low throughout. Power-down, sinking additional supply current unless  $\overline{\text{CS}}$  remains high. See the *Reference* section for information on reducing reference current during power-down.

### Digital Interface

The MAX153 has two basic interface modes set by the status of the MODE input pin. When MODE is low, the converter is in the RD mode; when MODE is high, the converter is set up for the WR-RD mode.

### Read Mode (MODE = 0)

In RD mode, conversion control and data access are controlled by the  $\overline{\text{RD}}$  input (Figure 3). The comparator inputs track the analog input voltage for the duration of  $t_{\text{p}}$ . A minimum of 160ns is required for the input to be acquired. A conversion is initiated by driving  $\overline{\text{RD}}$  low. With  $\mu$ Ps that can be forced into a wait state, hold  $\overline{\text{RD}}$  low until output data appears. The  $\mu$ P starts the conversion, waits, and then reads data with a single read instruction.

$\overline{\text{WR}}/\text{RDY}$  is configured as a status output (RDY) in RD mode, where it can drive the ready or wait input of a  $\mu$ P. RDY is an open-collector output (with no internal pullup) that goes low after the falling edge of  $\overline{\text{CS}}$  and goes high at the end of the conversion. If not used, the  $\overline{\text{WR}}/\text{RDY}$  pin can be left unconnected. The  $\overline{\text{INT}}$  output goes low at the end of the conversion and returns high on the rising edge of  $\overline{\text{CS}}$  or  $\overline{\text{RD}}$ .

### Write-Read Mode (MODE = 1)

Figures 4 and 5 show the operating sequence for the write-read (WR-RD) mode. The comparator inputs track the analog input voltage for the duration of  $t_{\text{p}}$ . A minimum of 160ns is required for the input voltage to be acquired. The conversion is initiated by a falling edge of  $\overline{\text{WR}}$ . When  $\overline{\text{WR}}$  returns high, the 4 MSBs flash result is latched into the output buffers and the 4 LSBs conversion begins. INT goes low about 380ns later, indicating conversion end, and the lower 4 data bits are latched into the output buffers. The data is then accessible 65ns to 130ns after RD goes low (see the *Timing Characteristics*).

If an externally controlled conversion time is required, drive  $\overline{\text{RD}}$  low 250ns after  $\overline{\text{WR}}$  goes high. This latches the lower 4 data bits and outputs the conversion result on D0–D7. A minimum 160ns delay is required from  $\overline{\text{INT}}$  going low to the start of another conversion ( $\overline{\text{WR}}$  going low).

Options for reading data from the converter include the following:

#### Using Internal Delay

The  $\mu$ P waits for the  $\overline{\text{INT}}$  output to go low before reading the data (Figure 4).  $\overline{\text{INT}}$  typically goes low 380ns after the rising edge of  $\overline{\text{WR}}$ , indicating the conversion is complete, and the result is available in the output latch. With  $\overline{\text{CS}}$  low, data outputs D0–D7 can be accessed by pulling  $\overline{\text{RD}}$  low.  $\overline{\text{INT}}$  is then reset by the rising edge of  $\overline{\text{CS}}$  or  $\overline{\text{RD}}$ .



The internal resistances from  $V_{REF+}$  and  $V_{REF-}$  may be as low as 1k $\Omega$ . Since current is still drawn by the reference inputs during power-down, reference supply current can be reduced during shutdown by using the circuit shown in Figure 7d. A logic-level n-channel MOSFET, connected between  $V_{REF-}$  and ground, disconnects the reference load when the ADC enters power-down. ( $PWRDN = \text{low}$ ). The FET should have no more than 0.5 $\Omega$  of on-resistance to maintain accuracy.

**Bypassing**

A 4.7 $\mu$ F electrolytic in parallel with a 0.1 $\mu$ F ceramic capacitor should be used to bypass  $V_{DD}$  to GND. These capacitors should have minimal lead length.

The reference inputs should be bypassed with 0.1 $\mu$ F capacitors, as shown in Figures 7a–7c.

**Input Current**

Figure 8 shows the equivalent circuit of the converter input. When the conversion starts and  $\overline{WR}$  is low,  $V_{IN}$  is connected to 16 0.6pF capacitors. During this acquisition phase, the input capacitors charge to the input voltage through the resistance of the internal analog switches (about 2k $\Omega$ ). In addition, about 12pF of stray capacitance must be charged. The input can be modeled as an equivalent RC network (Figure 9). As source impedance increases, the capacitors take longer to charge.

The typical 22pF input capacitance allows source resistance as high as 2.2k $\Omega$  without setup problems. For larger resistances, the acquisition time ( $t_p$ ) must be increased

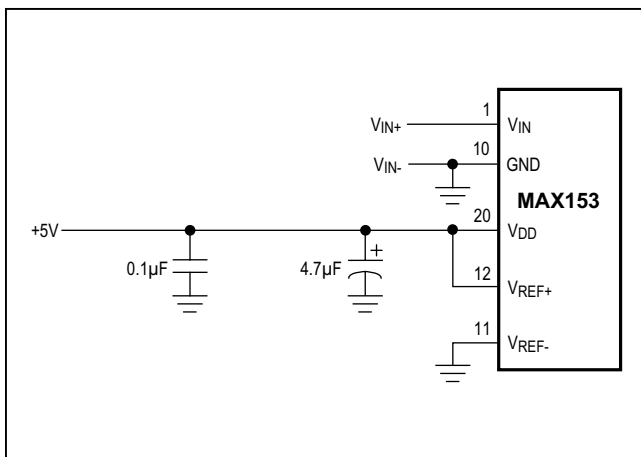

Figure 7a. Power Supply as Reference

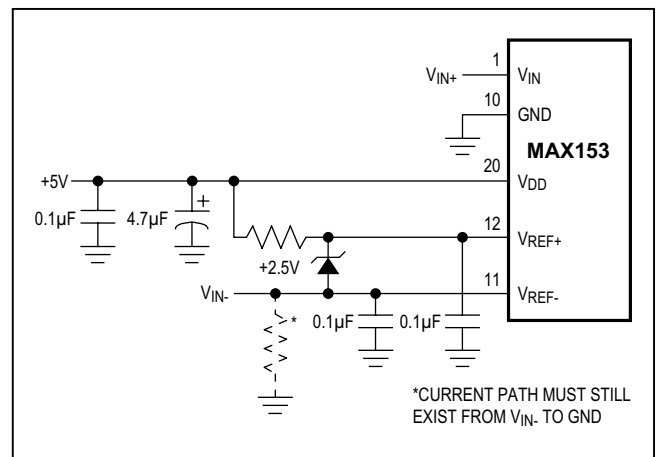

Figure 7c. Input Not Referenced to GND

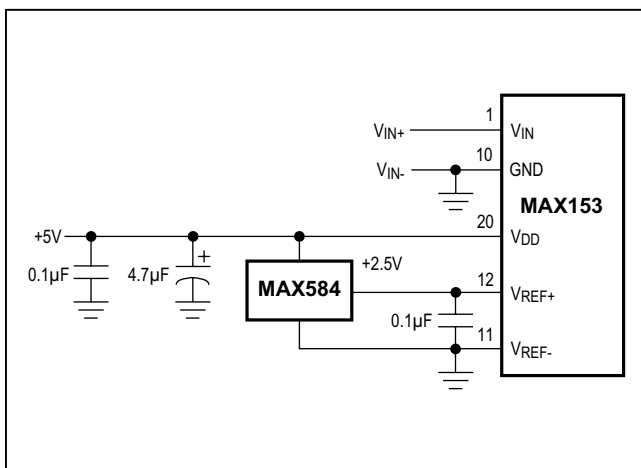

Figure 7b. External Reference, +2.5V Full Scale

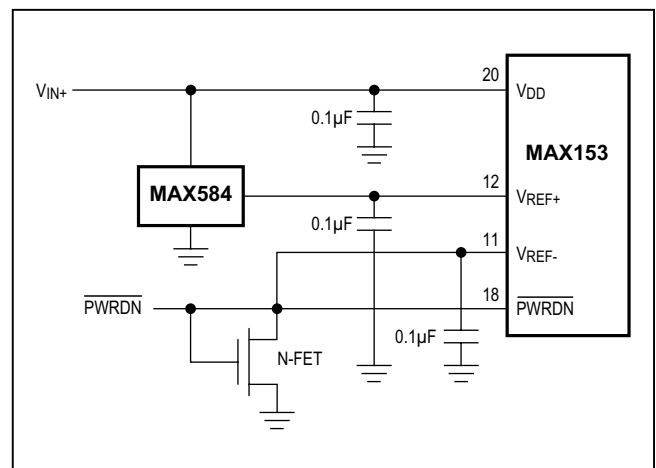

Figure 7d. An n-Channel MOSFET Switches Off the Reference Load During Power-Down

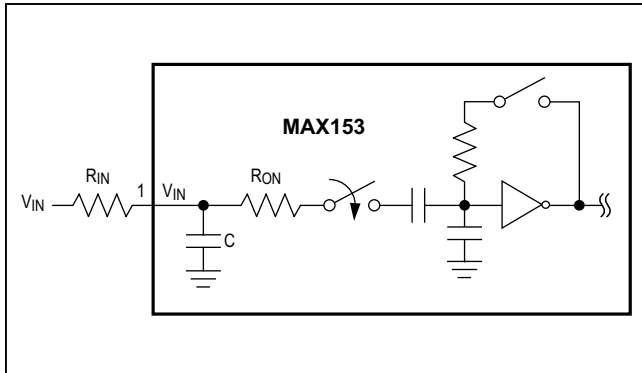

Figure 8. Equivalent Input Circuit

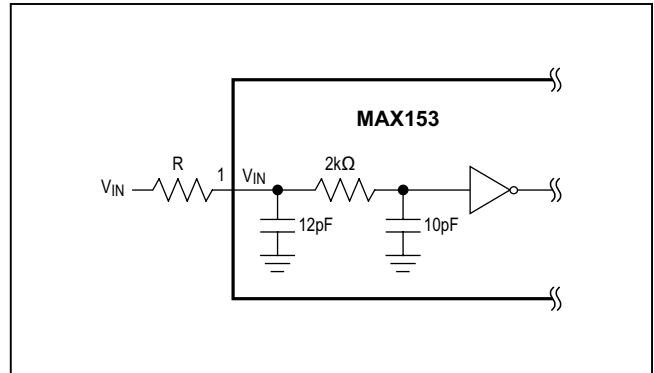

Figure 9. RC Network Equivalent Input Model

### Conversion Rate

The maximum sampling rate ( $f_{MAX}$ ) for the MAX153 is achieved in the WR-RD mode ( $t_{RD} < t_{INTL}$ ) and is calculated as follows:

$$f_{MAX} = \frac{1}{t_{WR} + t_{RD} + t_{RI} + t_p}$$

$$f_{MAX} = \frac{1}{250ns + 250ns + 150ns + 165ns}$$

$$f_{MAX} = 1.23MHz$$

where  $t_{WR}$  = Write pulse width

$t_{RD}$  = Delay between  $\overline{WR}$  and  $\overline{RD}$  pulses

$t_{RI}$  =  $\overline{RD}$  to  $\overline{INT}$  delay

$t_p$  = Delay time between conversions

### Signal-to-Noise Ratio and Effective Number of Bits

Signal-to-noise ratio (SNR) is the ratio of the RMS amplitude of the fundamental input frequency to the RMS amplitude of all other analog-to-digital output values. The output band is limited to one-half the A/D sample (conversion) rate. This ratio usually includes distortion as well as noise components. For this reason, the ratio is sometimes referred to as signal-to-noise plus distortion.

The theoretical minimum A/D noise is caused by quantization error and results directly from the ADC's resolution:  $SNR = (6.02N + 1.76)dB$ , where N is the number of bits of resolution. Therefore, a perfect 8-bit ADC can do no better than 50dB.

The FFT plot (*Typical Operating Characteristics*) shows the result of sampling a pure 200kHz sinusoid at a 1MHz rate. This FFT plot of the output shows the output level in various spectral bands.

The effective resolution, or effective number of bits, the ADC provides can be measured by transposing the equation that converts resolution to SNR:  $N = (SNR - 1.76)/6.02$ .

### Total Harmonic Distortion

Total harmonic distortion (THD) is the ratio of the RMS sum of all harmonics of the input signal (in the frequency band above DC and below one-half the sample rate) to the fundamental itself. This is expressed as:

$$THD = 20 \log \left[ \frac{\sqrt{(V_2^2 + V_3^2 + V_4^2 + \dots + V_N^2)}}{V_1} \right]$$

where  $V_1$  is the fundamental RMS amplitude, and  $V_2$  through  $V_N$  are the amplitudes of the 2nd through Nth harmonics.

### Peak Harmonic or Spurious Noise

Peak harmonic or spurious noise is the ratio of the fundamental RMS amplitude to the amplitude of the next largest spectral component (in the frequency band above DC and below one-half the sample rate). Usually this peak occurs at some harmonic of the input frequency, but if the ADC is exceptionally linear, it may occur only at a random peak in the ADC's noise floor.

### Intermodulation Distortion

An FFT plot of intermodulation distortion (IMD) is generated by sampling an analog input applied to the ADC. This input consists of very low distortion sine waves at two frequencies. A 2048 point plot for IMD of the MAX153 is shown in the *Typical Operating Characteristics*.

# MAX153

# 1Msps, $\mu$ P-Compatible, 8-Bit ADC with 1 $\mu$ A Power-Down

## Ordering Information

| PART       | TEMP RANGE     | PIN-PACKAGE |
|------------|----------------|-------------|
| MAX153CAP+ | 0°C to +70°C   | 20 SSOP**   |
| MAX153CPP+ | 0°C to +70°C   | 20 PDIP     |
| MAX153CWP+ | 0°C to +70°C   | 20 SO(W)    |
| MAX153C/D  | 0°C to +70°C   | Dice*       |
| MAX153EAP+ | -40°C to +85°C | 20 SSOP**   |
| MAX153EPP+ | -40°C to +85°C | 20 PDIP     |
| MAX153EWP+ | -40°C to +85°C | 20 Wide SO  |

+Denotes a lead(Pb)-free/RoHS-compliant package.

\*Contact factory for dice specifications.

\*\*Contact factory for availability of SSOP packages

## Package Information

For the latest package outline information and land patterns (footprints), go to [www.maximintegrated.com/packages](http://www.maximintegrated.com/packages). Note that a "+", "#", or "." in the package code indicates RoHS status only. Package drawings may show a different suffix character, but the drawing pertains to the package regardless of RoHS status.

| PACKAGE TYPE | PACKAGE CODE | OUTLINE NO.             | LAND PATTERN NO.        |
|--------------|--------------|-------------------------|-------------------------|
| 20 PDIP      | P20+3        | <a href="#">21-0043</a> | —                       |
| 20 SO(W)     | W20+2        | <a href="#">21-0042</a> | <a href="#">90-0108</a> |
| 20 SSOP      | A20+1        | <a href="#">21-0056</a> | <a href="#">90-0094</a> |

## Chip Information

PROCESS: BiCMOS

## Revision History

| REVISION NUMBER | REVISION DATE | DESCRIPTION               | PAGES CHANGED |
|-----------------|---------------|---------------------------|---------------|
| 0               | 7/92          | Initial release           | —             |
| 1               | 10/93         | Corrected die topography  | 11            |
| 2               | 1/12          | Removed military packages | 1–5           |

For pricing, delivery, and ordering information, please contact Maxim Direct at 1-888-629-4642, or visit Maxim Integrated's website at [www.maximintegrated.com](http://www.maximintegrated.com).

*Maxim Integrated cannot assume responsibility for use of any circuitry other than circuitry entirely embodied in a Maxim Integrated product. No circuit patent licenses are implied. Maxim Integrated reserves the right to change the circuitry and specifications without notice at any time. The parametric values (min and max limits) shown in the Electrical Characteristics table are guaranteed. Other parametric values quoted in this data sheet are provided for guidance.*

## Looking for pricing, stock, or lifecycle information?

Click below to explore more details on WIN SOURCE:

 [View MAX153CWP+T on WIN SOURCE](#)

 [Maxim Integrated](#) Information

## Optimize Your Supply Chain with WIN SOURCE Solutions

-  Global Sourcing Solution
-  Obsolete Management
-  Cost Control Management
-  Shortage Management
-  Alternative Solution
-  Excess Inventory Management