



# THE DATASHEET OF MAX1512ETA+T



EVALUATION KIT  
AVAILABLE



# EEPROM-Programmable TFT VCOM Calibrator

## General Description

The MAX1512 is a programmable VCOM-adjustment solution for thin-film transistor (TFT) liquid-crystal displays (LCDs). The MAX1512 simplifies the labor-intensive VCOM-adjustment process and replaces mechanical potentiometers, which significantly reduces labor costs, increases reliability, and enables automation.

The MAX1512 attaches to an external resistive voltage-divider and sinks a programmable current to set the VCOM voltage level. An internal 7-bit digital-to-analog converter (DAC) controls the sink current. The DAC is ratiometric relative to AVDD and is guaranteed to be monotonic over all operating conditions. This VCOM calibrator IC includes an EEPROM to store the desired VCOM voltage level. The EEPROM can be programmed repeatedly, giving TFT LCD manufacturers the flexibility to calibrate the display panel as many times as the manufacturing process requires.

The IC features a single-wire interface between the LCD panel and the programming circuit. The single-wire interface delivers both programming power and DAC-adjustment commands to minimize changes to panel connectors and production equipment. The MAX1512 is available in an 8-pin 3mm x 3mm TDFN package. A complete evaluation kit is available to simplify evaluation and production development.

## Applications

LCD Panels  
Notebook Computers  
Monitors  
LCD TVs

## Pin Configuration

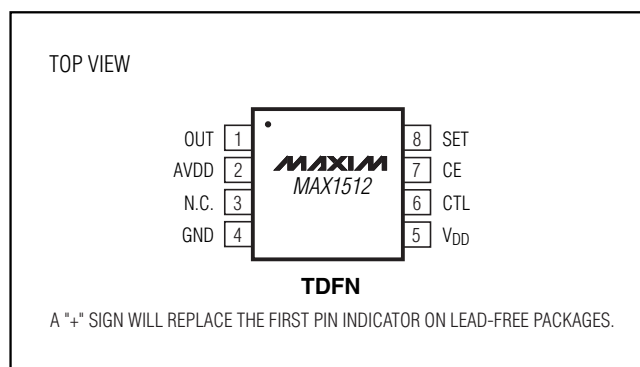

\*Patent Pending.

## Features

- ◆ 7-Bit Adjustable Sink-Current Output
- ◆ Resistor-Adjustable Full-Scale Range
- ◆ Guaranteed Monotonic Output Over Operating Range
- ◆ Single-Wire Adjustment and Programming\*
- ◆ EEPROM Stores VCOM Setting
- ◆ Interface Enable/Disable Control (CE)
- ◆ 2.6V to 3.6V Logic Supply-Voltage Operating Range (VDD)
- ◆ 4.5V to 20V Analog Supply-Voltage Range (VAVDD)
- ◆ VDD UVLO Protection
- ◆ 8-Pin 3mm x 3mm TDFN (0.8mm max)

## Ordering Information

PART	TEMP RANGE	PIN-PACKAGE
MAX1512ETA	-40°C to +85°C	8 TDFN 3mm x 3mm
MAX1512ETA+	-40°C to +85°C	8 TDFN 3mm x 3mm

+ Denotes lead-free package.

## Typical Operating Circuit

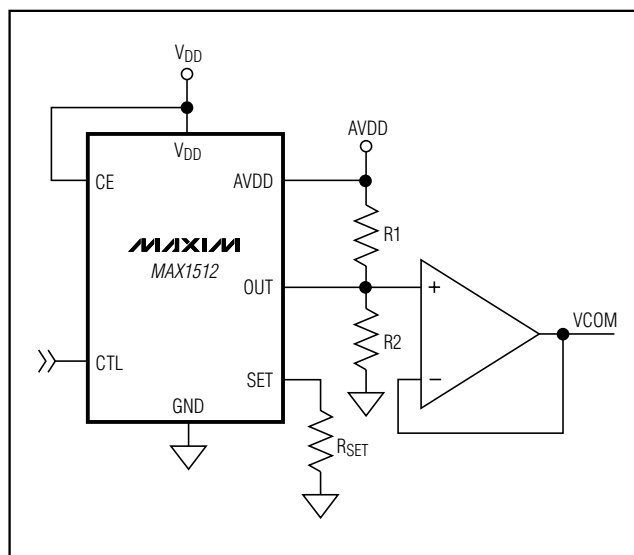

# EEPROM-Programmable TFT VCOM Calibrator

## ABSOLUTE MAXIMUM RATINGS

V <sub>DD</sub> , SET, CE to GND	-0.3V to +4V	above +70°C)	1951mW
OUT to GND	-0.3V to +14V	Operating Temperature Range	-40°C to +85°C
AVDD to GND	-0.3V to +24V	Junction Temperature	+150°C
CTL to GND	-0.3V to +16V	Storage Temperature Range	-65°C to +160°C
Continuous Power Dissipation (T <sub>A</sub> = +70°C)		Lead Temperature (soldering, 10s)	+300°C
8-Pin Thin QFN 3mm x 3mm (derate 24.4mW/°C)			

Stresses beyond those listed under "Absolute Maximum Ratings" may cause permanent damage to the device. These are stress ratings only, and functional operation of the device at these or any other conditions beyond those indicated in the operational sections of the specifications is not implied. Exposure to absolute maximum rating conditions for extended periods may affect device reliability.

## ELECTRICAL CHARACTERISTICS

(Circuit of Figure 1, V<sub>DD</sub> = 3V, V<sub>AVDD</sub> = 10V, V<sub>OUT</sub> = 5V, R<sub>SET</sub> = 30.1kΩ, T<sub>A</sub> = 0°C to +85°C, unless otherwise noted. Typical values are at T<sub>A</sub> = +25°C.) (Note 1)

PARAMETER	SYMBOL	CONDITIONS	MIN	TYP	MAX	UNITS
<b>SINK-CURRENT ADJUSTMENT</b>						
SET Voltage Resolution			7			Bits
SET Differential Nonlinearity		Guaranteed monotonic	-1		+1	LSB
SET Zero-Scale Error			-1	+1	+2	LSB
SET Full-Scale Error			-12		+12	LSB
SET Current	I <sub>SET</sub>				120	μA
SET External Resistance (Note 2)	R <sub>SET</sub>	To GND, V <sub>AVDD</sub> = 20V	10		200	kΩ
		To GND, V <sub>AVDD</sub> = 4.5V	2.25		45.00	
V <sub>SET</sub> / V <sub>AVDD</sub> Voltage Ratio		DAC full scale		0.05		V/V
V <sub>SET</sub> / V <sub>AVDD</sub> Factory-Set Voltage Ratio			0.024	0.025	0.026	V/V
<b>V<sub>DD</sub> SUPPLY</b>						
V <sub>DD</sub> Supply Range	V <sub>DD</sub>		2.6		3.6	V
V <sub>DD</sub> Supply Current	I <sub>DD</sub>	CE = V <sub>DD</sub>		32	55	μA
		CE = GND		12	20	
V <sub>DD</sub> Power-On Reset Threshold		Rising edge	2.2	2.5	2.7	V
		Falling edge	2.1	2.4	2.6	
V <sub>DD</sub> Power-On Reset Hysteresis				100		mV
<b>CONTROL AND PROGRAMMING</b>						
CE Input Low Voltage		2.6V < V <sub>DD</sub> < 3.6V			0.4	V
CE Input High Voltage		2.6V < V <sub>DD</sub> < 3.6V	1.6			V
CE Startup Time		(Note 3)			1	ms
CTL High Voltage		2.6V < V <sub>DD</sub> < 3.6V	0.70 x V <sub>DD</sub>	0.82 x V <sub>DD</sub>		V
CTL Float Voltage		2.6V < V <sub>DD</sub> < 3.6V	0.40 x V <sub>DD</sub>	0.62 x V <sub>DD</sub>		V
CTL Low Voltage		2.6V < V <sub>DD</sub> < 3.6V	0.20 x V <sub>DD</sub>	0.32 x V <sub>DD</sub>		V
CTL Rejected Pulse Width			20			μs
CTL Minimum Pulse Width					200	μs
CTL Minimum Time Between Pulses					10	μs
CTL Input Current		CTL = GND	-10			μA
		CTL = V <sub>DD</sub>			10	

# EEPROM-Programmable TFT VCOM Calibrator

MAX1512

## ELECTRICAL CHARACTERISTICS (continued)

(Circuit of Figure 1,  $V_{DD} = 3V$ ,  $V_{AVDD} = 10V$ ,  $V_{OUT} = 5V$ ,  $R_{SET} = 30.1k\Omega$ ,  $T_A = 0^{\circ}C$  to  $+85^{\circ}C$ , unless otherwise noted. Typical values are at  $T_A = +25^{\circ}C$ .) (Note 1)

PARAMETER	SYMBOL	CONDITIONS	MIN	TYP	MAX	UNITS
CTL EEPROM Program Voltage	$V_{PP}$	(Note 3)	15.25	15.5	15.75	V
<b>OUTPUT VOLTAGE</b>						
OUT Leakage Current		$V_{DD} = 2.1V$		1		nA
OUT Settling Time		To $\pm 0.5$ LSB error band		20		$\mu s$
$V_{OUT}$ Voltage Range	$V_{OUT}$		$V_{SET} + 0.5V$		13	V
<b>AVDD SUPPLY</b>						
$V_{AVDD}$ Supply Range	$V_{AVDD}$		4.5		20.0	V
AVDD Operating Current	$I_{AVDD}$	$V_{DD} = 2.1V$ , $V_{AVDD} = 20V$		0.04		$\mu A$
		$V_{AVDD} = 20V$		10	20	

## ELECTRICAL CHARACTERISTICS

( $V_{DD} = 3V$ ,  $V_{AVDD} = 10V$ ,  $V_{OUT} = 5V$ ,  $R_{SET} = 30.1k\Omega$ ,  $T_A = -40^{\circ}C$  to  $+85^{\circ}C$ , unless otherwise noted.) (Note 1)

PARAMETER	SYMBOL	CONDITIONS	MIN	TYP	MAX	UNITS
<b>SINK-CURRENT ADJUSTMENT</b>						
SET Differential Nonlinearity		Guaranteed monotonic	-1		+1	LSB
SET Zero-Scale Error			-1		+2	LSB
SET Full-Scale Error			-12		+12	LSB
SET Current	$I_{SET}$				120	$\mu A$
SET External Resistance (Note 2)	$R_{SET}$	To GND, $V_{AVDD} = 20V$	10		200	k $\Omega$
		To GND, $V_{AVDD} = 4.5V$	2.25		45.00	
<b>VDD SUPPLY</b>						
$V_{DD}$ Supply Range	$V_{DD}$		2.6		3.6	V
$V_{DD}$ Supply Current	$I_{DD}$	$CE = V_{DD}$			55	$\mu A$
		$CE = GND$			20	
$V_{DD}$ Power-On Reset Threshold		Rising edge	2.2		2.7	V
		Falling edge	2.1		2.6	
<b>CONTROL AND PROGRAMMING</b>						
CE Input Low Voltage		$2.6V < V_{DD} < 3.6V$			0.4	V
CE Input High Voltage		$2.6V < V_{DD} < 3.6V$	1.6			V
<b>AVDD SUPPLY</b>						
$V_{AVDD}$ Supply Range	$V_{AVDD}$		4.5		20.0	V
AVDD Operating Current	$I_{AVDD}$	$V_{AVDD} = 20V$			20	$\mu A$

**Note 1:** Limits are 100% production tested at  $T_A = +25^{\circ}C$ . Limits over the operating temperature range are guaranteed through correlation using standard quality control (SQC) methods.

**Note 2:** SET external resistor range is verified at DAC full scale.

**Note 3:** Guaranteed by design. Not production tested.

# EEPROM-Programmable TFT VCOM Calibrator

## Typical Operating Characteristics

(Circuit of Figure 1,  $V_{DD} = 3V$ ,  $V_{AVDD} = 10V$ ,  $V_{OUT} = 5V$ ,  $R_{SET} = 24.9k\Omega$ ,  $T_A = +25^\circ C$ , DAC half scale, unless otherwise noted.)

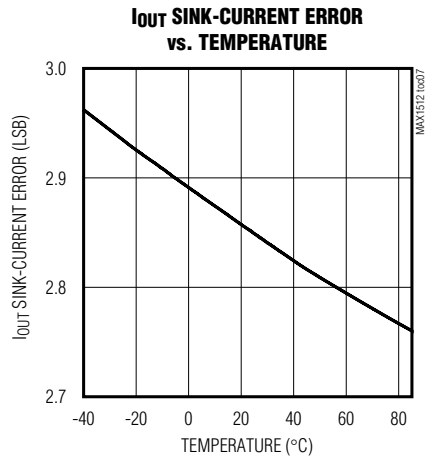
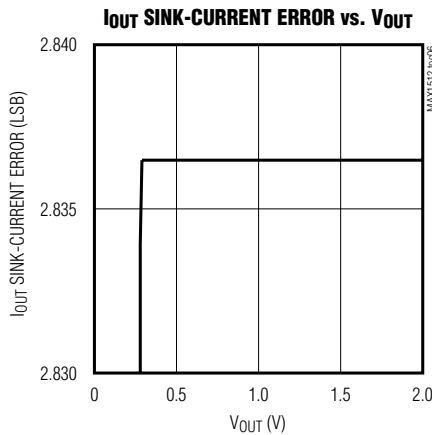
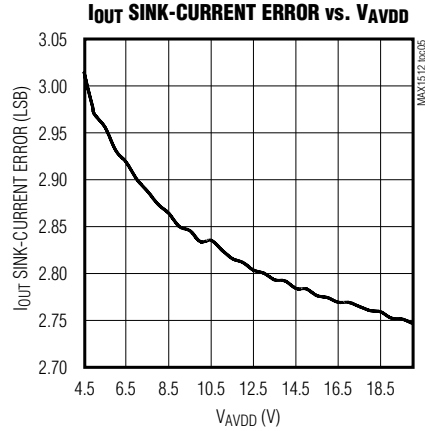
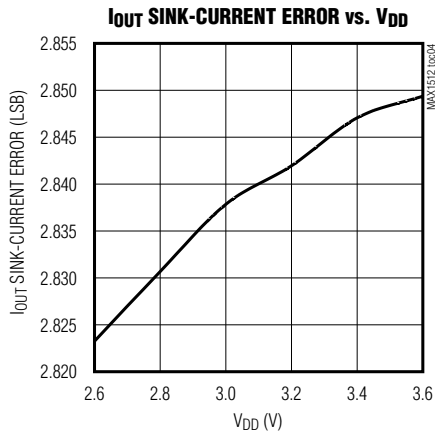
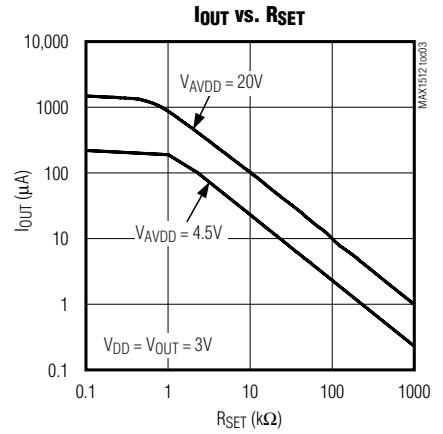
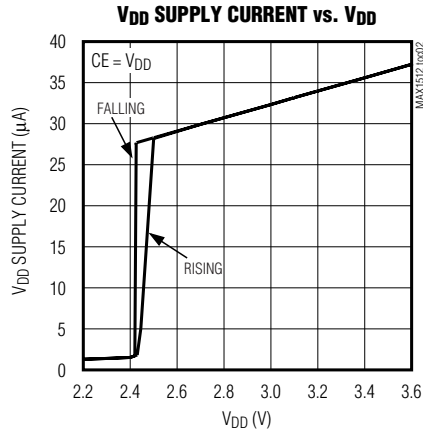
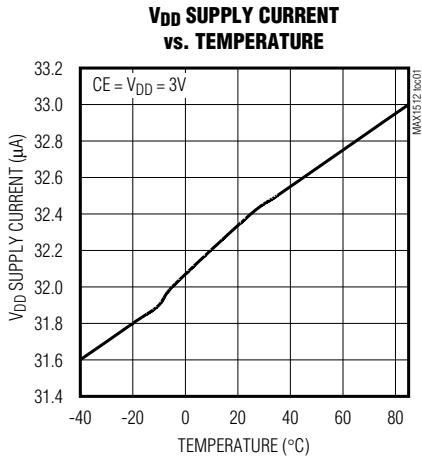

# EEPROM-Programmable TFT VCOM Calibrator

## Typical Operating Characteristics (continued)

(Circuit of Figure 1,  $V_{DD} = 3V$ ,  $V_{AVDD} = 10V$ ,  $V_{OUT} = 5V$ ,  $R_{SET} = 24.9k\Omega$ ,  $T_A = +25^\circ C$ , DAC half scale, unless otherwise noted.)

MAX1512

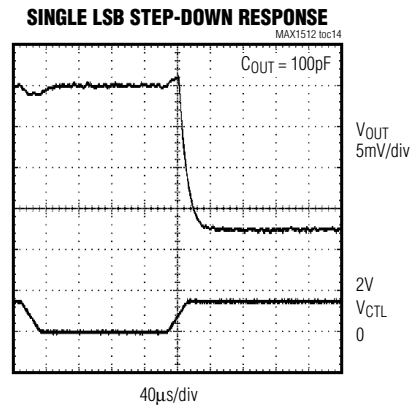
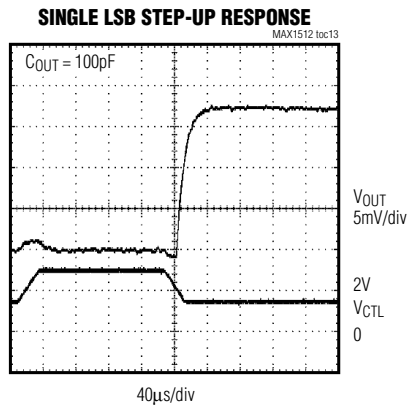
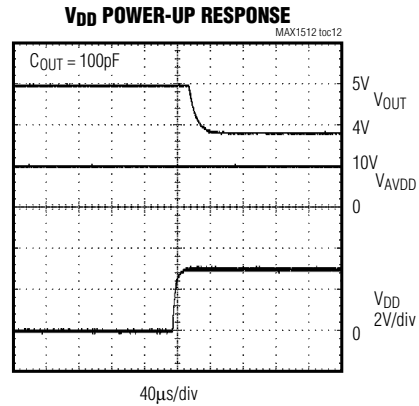
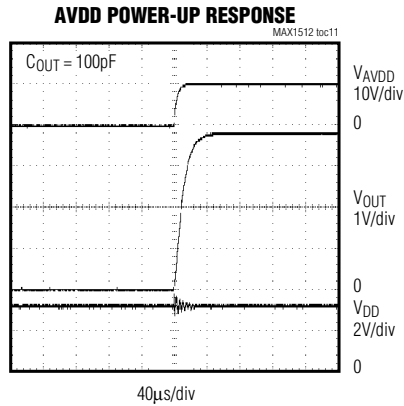
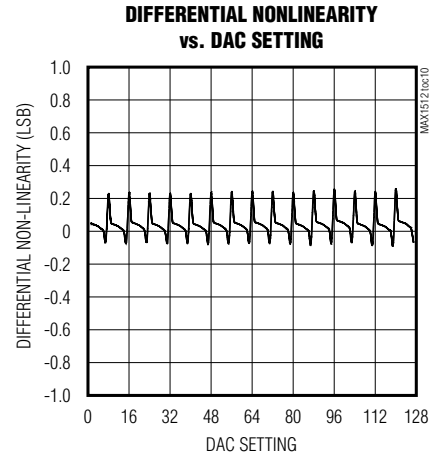
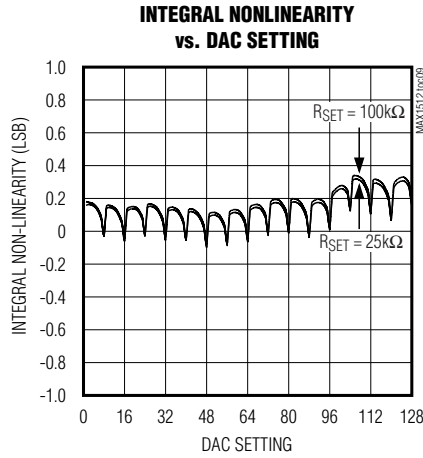
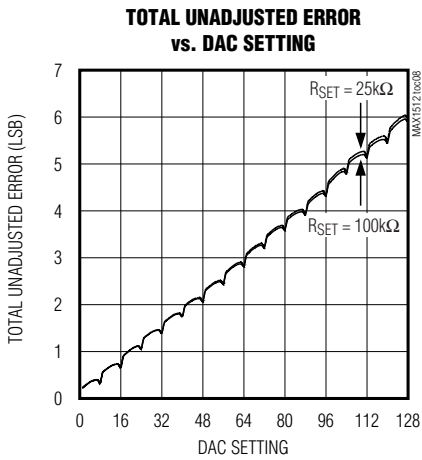

# EEPROM-Programmable TFT VCOM Calibrator

## Pin Description

PIN	NAME	FUNCTION
1	OUT	Adjustable Sink-Current Output. OUT connects to the resistive voltage-divider between AVDD and GND that sets the VCOM voltage. I <sub>OUT</sub> lowers the divider voltage by an adjustable amount. See the SET pin description.
2	AVDD	High-Voltage Analog Supply. Connects to the panel source-driver supply rail.
3	N.C.	No Connect. Not internally connected.
4	GND	Ground
5	VDD	Supply Input. +2.6V to +3.6V input range.
6	CTL	VCOM Adjustment and EEPROM Programming Control. CTL sets the internal DAC code and programs the EEPROM. A pulse-control method is used to adjust the VCOM level. See the <i>VCOM Adjustment (CTL)</i> section. To program the DAC setting into the EEPROM as the power-on default, drive CTL to the EEPROM programming voltage using the correct timing and voltage ramp rates. See the <i>EEPROM Programming (CTL)</i> section.
7	CE	Control Interface Enable. Connect CE to V <sub>DD</sub> to enable the CTL input. Connect CE to GND to disable the CTL input and reduce the supply current.
8	SET	Full-Scale Sink-Current Adjustment Input. Connect a resistor, R <sub>SET</sub> , from SET to GND to set the full-scale adjustable sink current. The full-scale adjustable sink current is equal to: $\left( \frac{V_{AVDD}}{20 \times R_{SET}} \right) I_{OUT}$ is equal to the current through R <sub>SET</sub> .

## Detailed Description

The MAX1512 is a solid-state alternative to mechanical potentiometers used for adjusting the LCD backplane voltage (VCOM) in TFT LCD displays. The MAX1512 attaches to an external resistive voltage-divider and sinks a programmable current (I<sub>OUT</sub>), which sets the VCOM level (Figure 1). An internal 7-bit DAC controls the sink current and allows the user to increase or decrease the VCOM level (Figure 2). The DAC is ratio-metric relative to AVDD and is monotonic over all operating conditions. The user can store the DAC setting in an internal EEPROM. On power-up, the EEPROM presets the DAC to the last stored setting. The single-wire interface between the LCD panel and the programming circuit adjusts the DAC, programs the EEPROM, and provides programming power.

The resistive voltage-divider and the AVDD supply set the maximum value of VCOM. The MAX1512 sinks current from the voltage-divider to reduce the VCOM level. The external resistor R<sub>SET</sub> sets the full-scale sink current and the minimum value of VCOM.

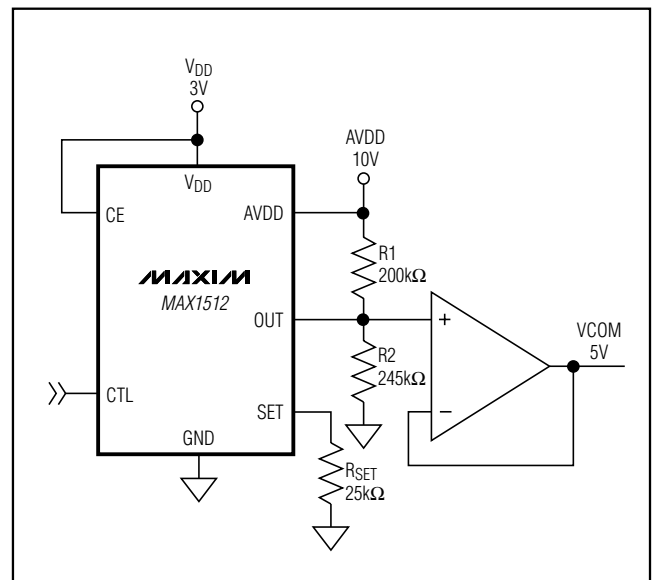

Figure 1. Standard Application Circuit

# EEPROM-Programmable TFT VCOM Calibrator

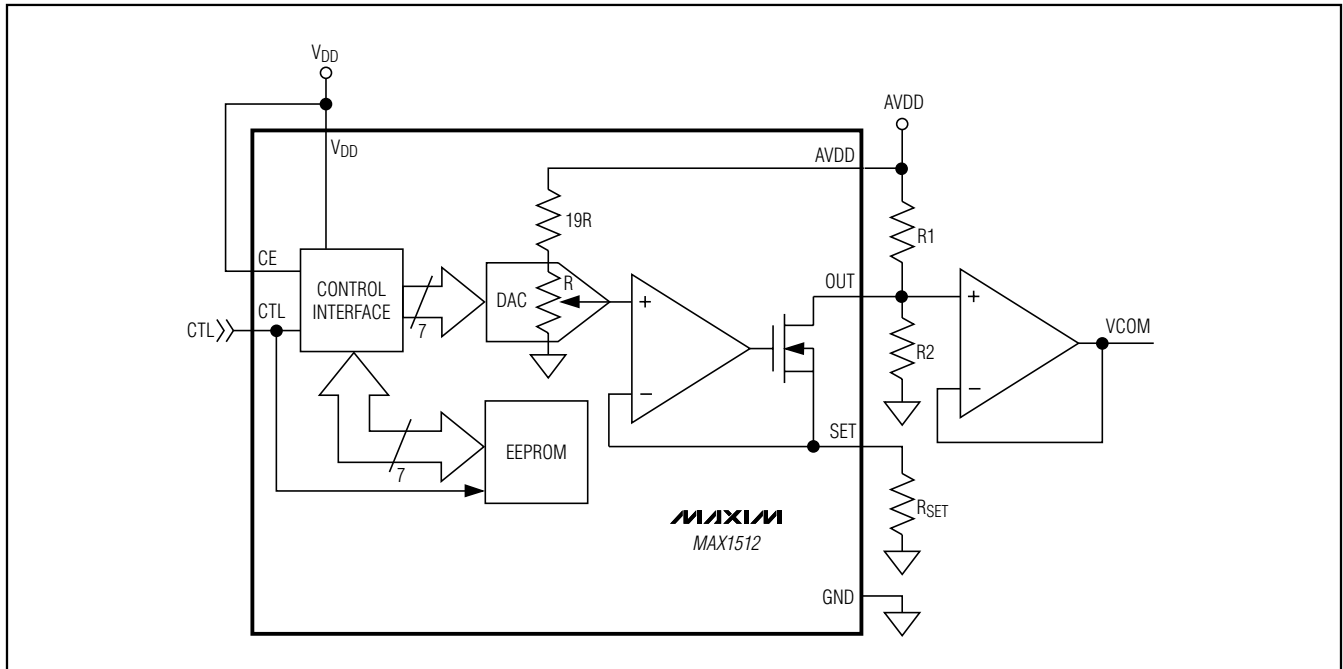

Figure 2. Simplified Functional Diagram

## Setting the VCOM Adjustment Range (RSET)

The external resistive voltage-divider sets the maximum value of the VCOM adjustment range. RSET sets the full-scale sink current, I<sub>OUT</sub>, which determines the minimum value of the VCOM adjustment range. Large RSET values increase resolution but decrease the VCOM adjustment range. Calculate R1, R2, and RSET using the following procedure:

- 1) Choose the maximum VCOM level (V<sub>MAX</sub>), the minimum VCOM level (V<sub>MIN</sub>), and the AVDD supply voltage (V<sub>AVDD</sub>).
- 2) Calculate the R1 / R2 ratio:

$$\frac{R1}{R2} \cong \frac{V_{AVDD}}{V_{MAX}} - 1$$

- 3) Calculate the R1 / RSET ratio:

$$\frac{R1}{R_{SET}} \cong \frac{(V_{MAX} - V_{MIN})}{V_{MAX}} \times 20$$

- 4) Choose RSET according to the limits shown in the *Electrical Characteristics* section and calculate the values for R1 and R2.
- 5) The resulting resolution is:

$$\text{Resolution} = \frac{(V_{MAX} - V_{MIN})}{127}$$

A complete design example is given below:

- 1) V<sub>MAX</sub> = 5V, V<sub>MIN</sub> = 3V, V<sub>AVDD</sub> = 10V
- 2)  $\frac{R1}{R2} \cong \frac{10}{5} - 1 = 1$
- 3)  $\frac{R1}{R_{SET}} = 20 \times \frac{(5-3)}{5} = 8$
- 4) If R<sub>SET</sub> = 24.9kΩ, then R1 = 200kΩ and R2 = 200kΩ
- 5) Resolution = 15.75mV

# EEPROM-Programmable TFT VCOM Calibrator

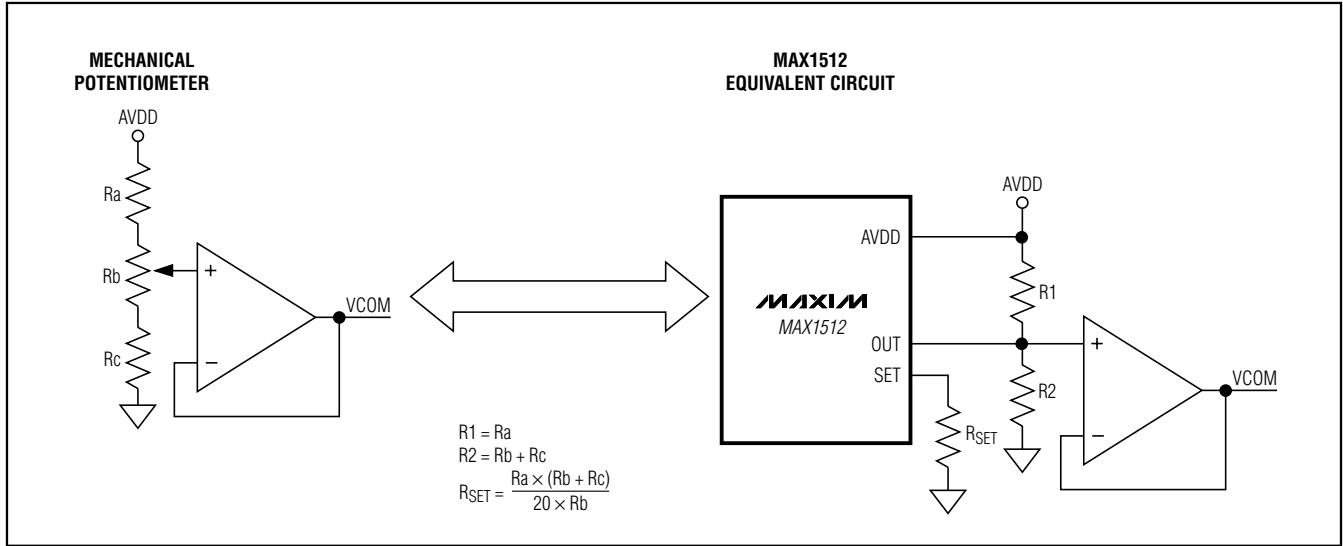

Figure 3. Replacement of Mechanical/Potentiometer Circuit

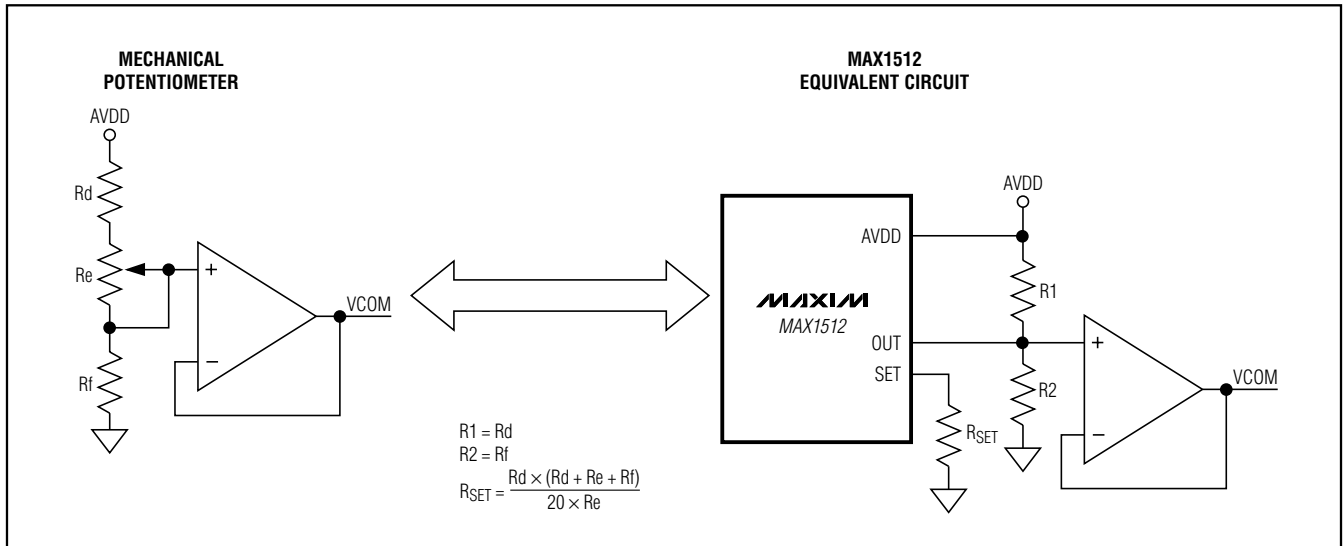

Figure 4. Replacement of Mechanical/Potentiometer Circuit

### Translating Existing Potentiometer Circuits

Existing VCOM adjustment circuits using conventional mechanical potentiometers can be translated into MAX1512 circuits. Figures 3 and 4 show two common adjustment circuits and their equivalent MAX1512 circuits.

### Interface Enable/Disable (CE)

The MAX1512 control interface can be disabled to reduce the VDD supply current. Connect CE to GND to reduce the typical supply current from 32µA to 12µA. Connect CE to VDD to enable the control interface.

# EEPROM-Programmable TFT VCOM Calibrator

MAX1512

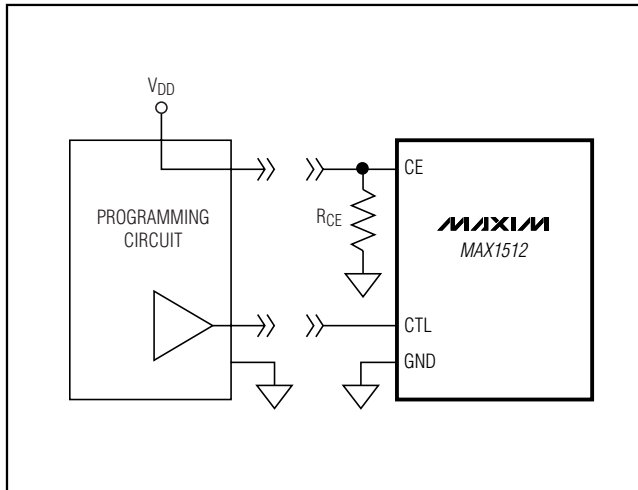

Figure 5. Optional Circuit to Drive CE

The programming circuit in Figure 5 drives CE high to enable the CTL input when it is connected. When the programming circuit is not connected, CE is pulled low through resistor  $R_{CE}$ , which disables the CTL input. The CTL input is relatively immune to noise and brief voltage transients. It can be safely left continuously enabled if higher supply current is acceptable.

## VCOM Adjustment (CTL)

Pulse CTL low for more than  $200\mu\text{s}$  to increment the DAC setting, which increases the OUT sink current and lowers the VCOM level by 1 least-significant bit (LSB) (Figure 6). Similarly, pulse CTL high for more than  $200\mu\text{s}$  to decrement the DAC setting, which decreases the OUT sink current and increases the VCOM level by 1 LSB.

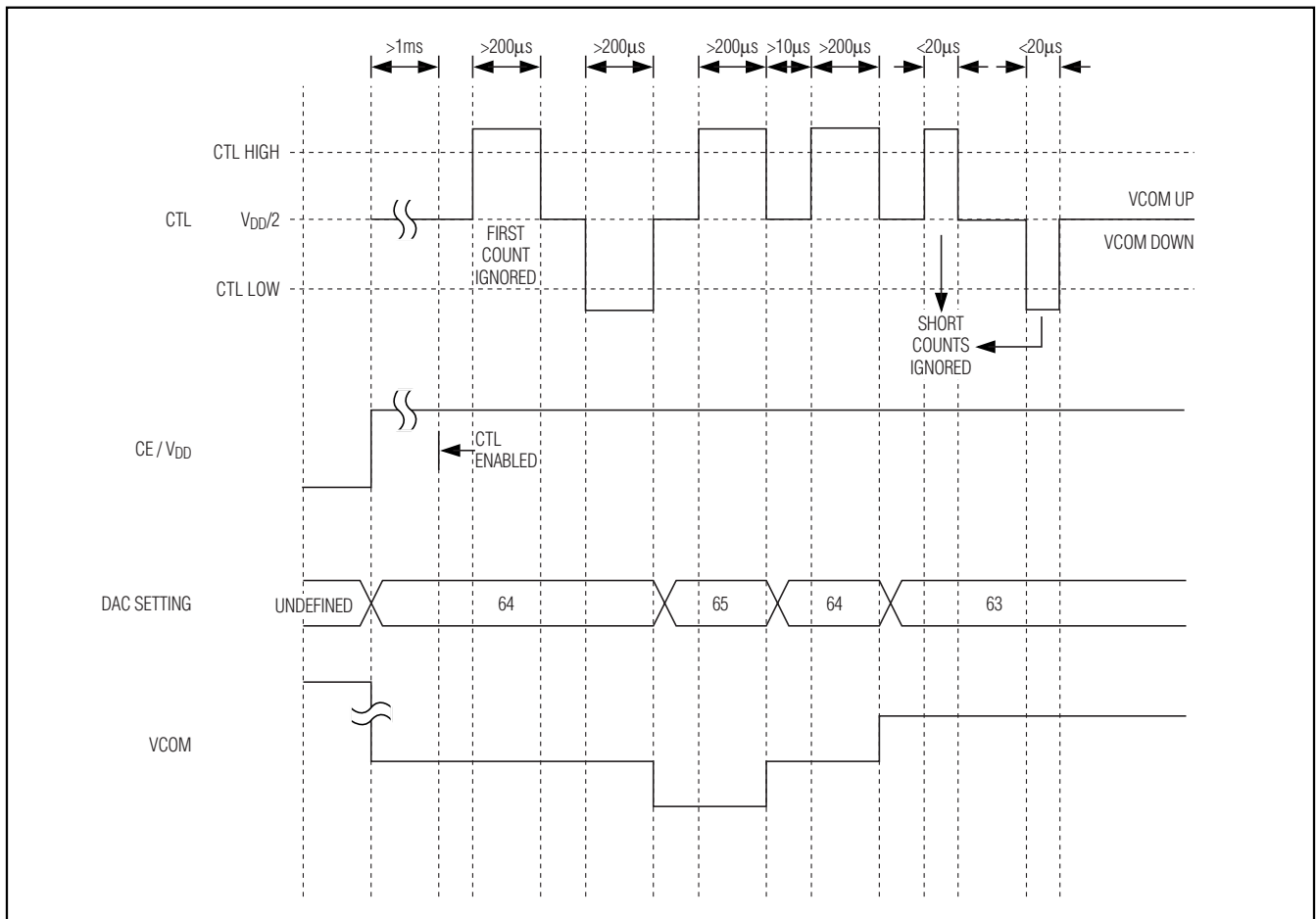

Figure 6. VCOM Adjustment

## EEPROM-Programmable TFT VCOM Calibrator

To avoid unintentional VCOM adjustment, the MAX1512 is guaranteed to reject CTL pulses shorter than 20 $\mu$ s. In addition, to avoid the possibility of a single false pulse caused by power-up sequencing between V<sub>DD</sub> and CTL, the very first pulse is ignored.

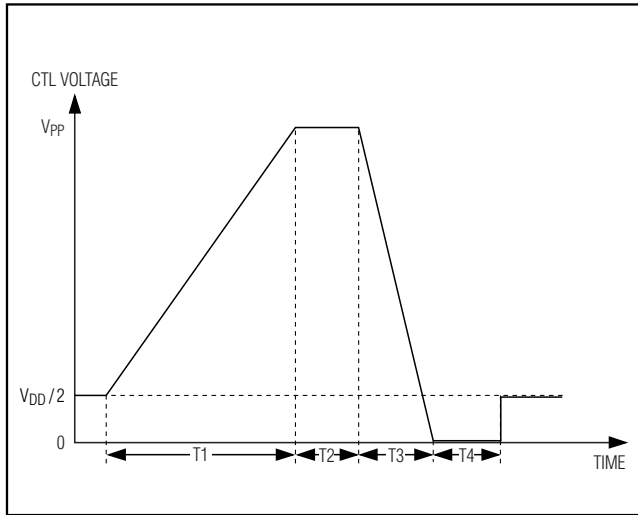

Figure 7. EEPROM Programming

### EEPROM Programming (CTL)

To program the EEPROM, apply the EEPROM programming waveform through the CTL interface (Figure 7). The control interface delivers programming power and DAC adjustment commands on the same wire. This single-wire approach minimizes the number of connections from the programming circuit to the LCD panel.

To apply the EEPROM programming waveform, carefully ramp CTL from midscale (V<sub>DD</sub> / 2) to the programming voltage, V<sub>PP</sub>, in 7.5ms as shown in Figure 7. If the ramp is generated digitally, use at least 45 steps to achieve the required 320mV ramp resolution. During the ramp time, VCOM adjustment is disabled and the EEPROM cells are biased in preparation for programming. After reaching V<sub>PP</sub>, hold CTL at V<sub>PP</sub> for 1ms. During the EEPROM program time, the EEPROM stores the DAC setting. Next, drive CTL to ground in less than 1ms and hold for at least 200 $\mu$ s. Finally, drive CTL to V<sub>DD</sub> / 2 to complete the write cycle. The EEPROM is factory set to half scale. Follow the *EEPROM Programming Specifications* in Table 1 to guarantee reliable EEPROM programming. Violating the specifications can damage the EEPROM or affect data retention.

A complete evaluation kit is available to simplify evaluation and production development.

Table 1. EEPROM Programming Specifications

PARAMETER	SYMBOL	MIN	TYP	MAX	UNITS
CTL Programming Voltage	V <sub>PP</sub>	15.25	15.5	15.75	V
CTL Programming Ramp	T1	7.0	7.5	8.0	ms
EEPROM Program Time	T2	0.9	1.0	1.1	ms
V <sub>PP</sub> Fall Time	T3	10		1000	$\mu$ s
Done Hold Time	T4	200			$\mu$ s

# EEPROM-Programmable TFT VCOM Calibrator

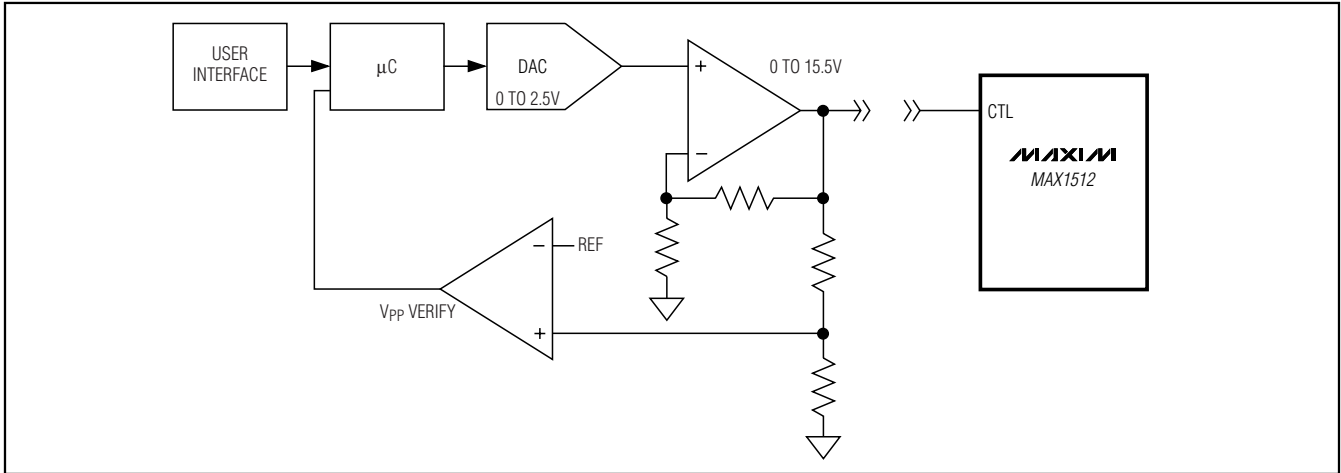

Figure 8. Conceptual Programming Circuit

## Applications Information

The VCOM adjustment and the EEPROM programming must be performed with an external programming circuit. Refer to the MAX1512 evaluation kit for a complete programming circuit solution.

Use a circuit similar to the conceptual diagram shown in Figure 8 to drive CTL. The accuracy of the programming voltage ( $V_{PP}$ ) is critical for proper MAX1512 data retention. The use of a comparator is recommended to verify the correct programming voltage has been reached. A complete design example of a CTL programming circuit is presented in the MAX1512 evaluation kit data sheet.

### Electrostatic Discharge (CTL, CE)

Often, CTL and CE are exposed at the panel connector and are therefore subject to electrostatic discharge (ESD). Resistor-capacitor (RC) filters can be employed at these inputs to improve their ESD performance (Figure 9).

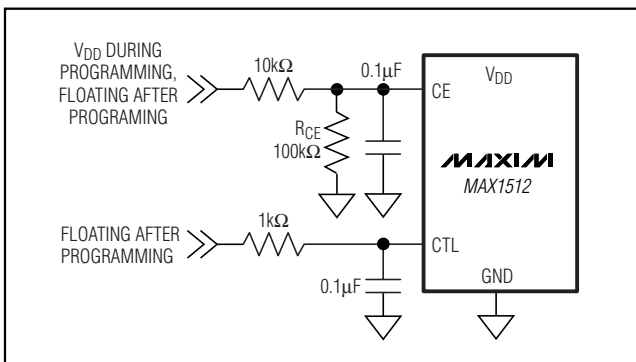

Figure 9. Improved EOS/Surge Performance

If the CE panel connector is to be left floating after programming, be sure to include a resistor to ground ( $R_{CE}$ ) to ensure a valid logic-low on CE. The time constant for a CE filter is not critical but the driving resistor must have a much lower resistance than  $R_{CE}$  to properly drive CE.

If a filter is used at the CTL panel connector, its RC time-constant should be short enough to avoid interfering with CTL pulses or EEPROM programming timing. A time constant less than  $200\mu s$  does not interfere with EEPROM programming. To avoid interfering with CTL pulses, make the time constant small compared to the CTL pulsewidth used.

### Leakage Current (CTL)

The CTL pin is internally biased to  $V_{DD} / 2$ , but it is sensitive to leakage currents above  $0.1\mu A$ . When CTL is not driven, avoid leakage currents around the CTL pin. Otherwise, reinforce the  $V_{DD} / 2$  set point with an external resistive voltage-divider.

### Layout Information

Use the following guidelines for good layout:

- Place the VCOM buffer and the R1/R2 voltage-divider close to the OUT pin (Figure 1). Keep the VCOM buffer and the R1/R2 voltage-divider close to each other.
- Place RSET close to SET.
- In noisy environments, bypass capacitors may be desired on  $V_{DD}$  and/or  $V_{AVDD}$ . Keep any bypass capacitors close to the IC with short connections to the pins.

Refer to the MAX1512 evaluation kit for an example of proper board layout.

# EEPROM-Programmable TFT VCOM Calibrator

## Package Information

(The package drawing(s) in this data sheet may not reflect the most current specifications. For the latest package outline information go to [www.maxim-ic.com/packages](http://www.maxim-ic.com/packages).)

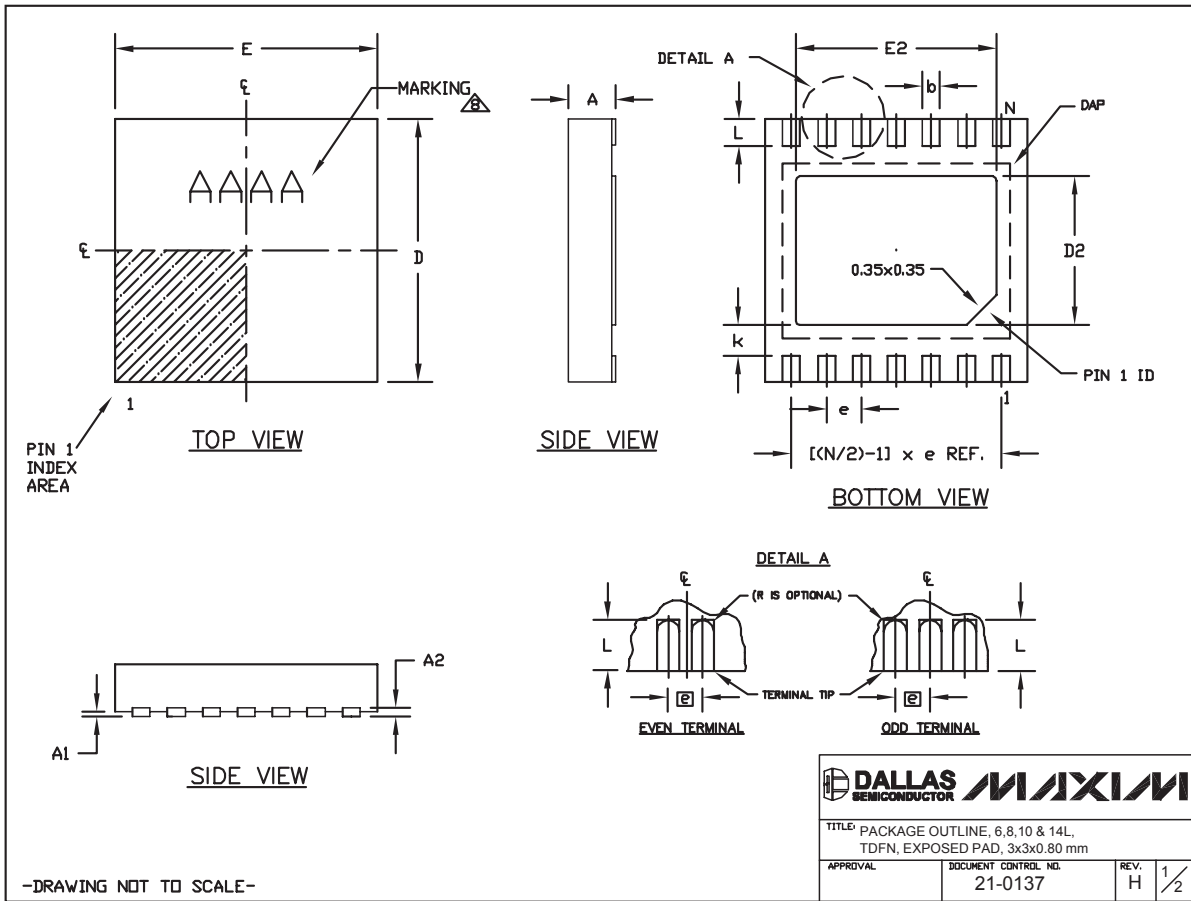

# EEPROM-Programmable TFT VCOM Calibrator

## Package Information (continued)

(The package drawing(s) in this data sheet may not reflect the most current specifications. For the latest package outline information go to [www.maxim-ic.com/packages](http://www.maxim-ic.com/packages).)

MAX1512

COMMON DIMENSIONS			PACKAGE VARIATIONS							
SYMBOL	MIN.	MAX.	PKG. CODE	N	D2	E2	e	JEDEC SPEC	b	[(N/2)-1] x e
A	0.70	0.80	T633-1	6	1.50±0.10	2.30±0.10	0.95 BSC	MO229 / WEEA	0.40±0.05	1.90 REF
D	2.90	3.10	T633-2	6	1.50±0.10	2.30±0.10	0.95 BSC	MO229 / WEEA	0.40±0.05	1.90 REF
E	2.90	3.10	T833-1	8	1.50±0.10	2.30±0.10	0.65 BSC	MO229 / WEEC	0.30±0.05	1.95 REF
A1	0.00	0.05	T833-2	8	1.50±0.10	2.30±0.10	0.65 BSC	MO229 / WEEC	0.30±0.05	1.95 REF
L	0.20	0.40	T833-3	8	1.50±0.10	2.30±0.10	0.65 BSC	MO229 / WEEC	0.30±0.05	1.95 REF
k	0.25 MIN.		T1033-1	10	1.50±0.10	2.30±0.10	0.50 BSC	MO229 / WEED-3	0.25±0.05	2.00 REF
A2	0.20 REF.		T1033-2	10	1.50±0.10	2.30±0.10	0.50 BSC	MO229 / WEED-3	0.25±0.05	2.00 REF
			T1433-1	14	1.70±0.10	2.30±0.10	0.40 BSC	----	0.20±0.05	2.40 REF
			T1433-2	14	1.70±0.10	2.30±0.10	0.40 BSC	----	0.20±0.05	2.40 REF

NOTES:

- ALL DIMENSIONS ARE IN mm. ANGLES IN DEGREES.
- COPLANARITY SHALL NOT EXCEED 0.08 mm.
- WARPAGE SHALL NOT EXCEED 0.10 mm.
- PACKAGE LENGTH/PACKAGE WIDTH ARE CONSIDERED AS SPECIAL CHARACTERISTIC(S).
- DRAWING CONFORMS TO JEDEC MO229, EXCEPT DIMENSIONS "D2" AND "E2", AND T1433-1 & T1433-2.
- "N" IS THE TOTAL NUMBER OF LEADS.
- NUMBER OF LEADS SHOWN ARE FOR REFERENCE ONLY.
- MARKING IS FOR PACKAGE ORIENTATION REFERENCE ONLY.



TITLE: PACKAGE OUTLINE, 6, 8, 10 & 14L,  
TDFN, EXPOSED PAD, 3x3x0.80 mm

APPROVAL	DOCUMENT CONTROL NO.	REV.	
	21-0137	H	2/2

-DRAWING NOT TO SCALE-

## Revision History



Pages changes at Rev 3: 1, 11, 12

Maxim cannot assume responsibility for use of any circuitry other than circuitry entirely embodied in a Maxim product. No circuit patent licenses are implied. Maxim reserves the right to change the circuitry and specifications without notice at any time.

13 **Maxim Integrated Products, 120 San Gabriel Drive, Sunnyvale, CA 94086 408-737-7600**

## Looking for pricing, stock, or lifecycle information?

Click below to explore more details on WIN SOURCE:

-  [View MAX1512ETA+T on WIN SOURCE](#)
-  [Maxim Integrated Information](#)

## Optimize Your Supply Chain with WIN SOURCE Solutions

-  Global Sourcing Solution
-  Obsolete Management
-  Cost Control Management
-  Shortage Management
-  Alternative Solution
-  Excess Inventory Management