



**THE DATASHEET OF
MAX13487EESA+**



MAX13487E/MAX13488E

Half-Duplex RS-485-/RS-422- Compatible Transceiver with AutoDirection Control

General Description

The MAX13487E/MAX13488E +5V, half-duplex, $\pm 15\text{kV}$ ESD-protected RS-485/RS-422-compatible transceivers feature one driver and one receiver. The MAX13487E/MAX13488E include a hot-swap capability to eliminate false transitions on the bus during power-up or live insertion.

The MAX13487E/MAX13488E feature Maxim's proprietary AutoDirection control. This architecture makes the devices ideal for applications, such as isolated RS-485 ports, where the driver input is used in conjunction with the driver-enable signal to drive the differential bus.

The MAX13487E features reduced slew-rate drivers that minimize EMI and reduce reflections caused by improperly terminated cables, allowing error-free transmission up to 500kbps. The MAX13488E driver slew rate is not limited, allowing transmit speeds up to 16Mbps.

The MAX13487E/MAX13488E feature a 1/4-unit load receiver input impedance, allowing up to 128 transceivers on the bus. These devices are intended for half-duplex communications. All driver outputs are protected to $\pm 15\text{kV}$ ESD using the Human Body Model. The MAX13487E/MAX13488E are available in an 8-pin SO package. The devices operate over the extended -40°C to $+85^\circ\text{C}$ temperature range.

Applications

- Isolated RS-485 Interfaces
- Utility Meters
- Industrial Controls
- Industrial Motor Drives
- Automated HVAC Systems

Ordering Information/ Selector Guide

PART	PIN-PACKAGE	SLEW-RATE LIMITED
MAX13487EESA+	8 SO	Yes
MAX13488EESA+	8 SO	No

+Denotes a lead(Pb)-free/RoHS-compliant package.

Note: All devices operate over the -40°C to $+85^\circ\text{C}$ temperature range.

Benefits and Features

- AutoDirection Saves Space and BOM Cost
 - AutoDirection Enables Driver Automatically on Transmission, Eliminating an Opto or Other Discrete Means of Isolation
 - 8-Pin SO Package
- Robust Protection Features for Telecom, Industrial, and Isolated Applications
 - Hot-Swap Capability to Eliminate False Transitions on the Bus During Power-Up or Live Insertion
 - Extended ESD Protection for RS-485 I/O Pins ($\pm 15\text{kV}$ Human Body Model)
- Options Optimize Designs for Speed or Errorless Data Transmission
 - Enhanced Slew-Rate Limiting Facilitates Error-Free Data Transmission (MAX13487E)
 - High-Speed Version (MAX13488E) Allows for Transmission Speeds Up to 16Mbps
- 1/4-Unit Load, Allowing Up to 128 Transceivers on the Bus

Functional Diagram

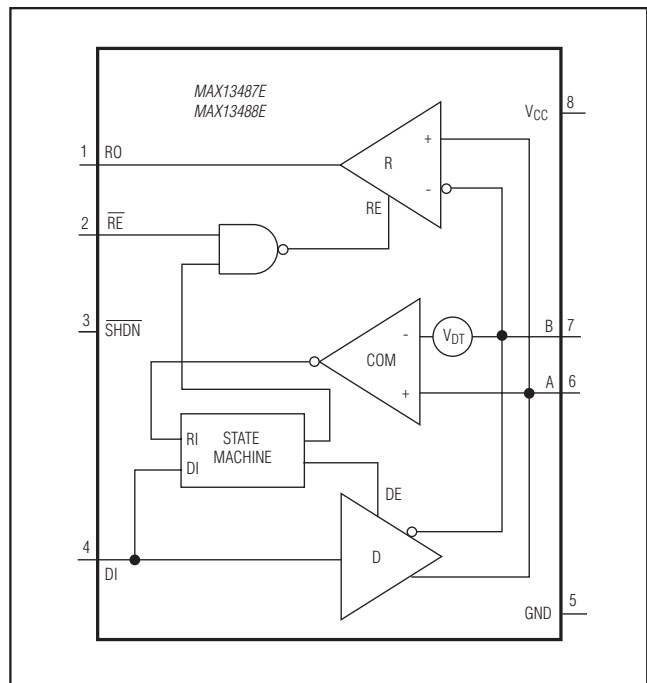

Pin Configuration/Typical Application Circuit appear at end of data sheet.

Absolute Maximum Ratings

(All voltages referenced to GND.)

Supply Voltage V_{CC}	+6V
SHDN, \overline{RE} , DI	-0.3V to +6V
A, B	-8V to +13V
Short-Circuit Duration (RO, A, B) to GND	Continuous
Continuous Power Dissipation ($T_A = +70^\circ\text{C}$) 8-Pin SO (derate 5.9mW/ $^\circ\text{C}$ above $+70^\circ\text{C}$)	471mW

Operating Temperature Range	-40 $^\circ\text{C}$ to +85 $^\circ\text{C}$
Junction Temperature	+150 $^\circ\text{C}$
Storage Temperature Range	-65 $^\circ\text{C}$ to +150 $^\circ\text{C}$
Lead Temperature (soldering 10s)	+300 $^\circ\text{C}$

Stresses beyond those listed under "Absolute Maximum Ratings" may cause permanent damage to the device. These are stress ratings only, and functional operation of the device at these or any other conditions beyond those indicated in the operational sections of the specifications is not implied. Exposure to absolute maximum rating conditions for extended periods may affect device reliability.

Electrical Characteristics

($V_{CC} = +5V \pm 5\%$, $T_A = T_{MIN}$ to T_{MAX} , unless otherwise noted. Typical values are at $V_{CC} = +5V$ and $T_A = +25^\circ\text{C}$.) (Note 1)

PARAMETER	SYMBOL	CONDITIONS	MIN	TYP	MAX	UNITS
DRIVER						
Differential Driver Output	V_{OD}	$R_{DIFF} = 100\Omega$, Figure 1	2.0		V_{CC}	V
		$R_{DIFF} = 54\Omega$, Figure 1	1.5			
		No load			V_{CC}	
Driver Common-Mode Output Voltage	V_{OC}	$R_L = 100\Omega$ or 54Ω , Figure 1		$V_{CC}/2$	3	V
Driver Disable Threshold	V_{DT}	Figure 2 (Note 2)	+0.6		+1	V
Input-High Voltage	V_{IH}	DI, \overline{SHDN} , \overline{RE}	2.0			V
Input-Low Voltage	V_{IL}	DI, \overline{SHDN} , \overline{RE}			0.8	V
Input Current	I_{IN}	DI, \overline{SHDN} , \overline{RE}			± 1	μA
Driver Short-Circuit Output Current (Note 3)	I_{OSD}	$0V \leq V_{OUT} \leq +12V$	+50		+250	mA
		$-7V \leq V_{OUT} \leq 0V$	-250		-50	
Driver Short-Circuit Foldback Output Current (Note 3)	I_{OSDF}	$(V_{CC} - 1V) \leq V_{OUT} \leq +12V$	20			mA
		$-7V \leq V_{OUT} \leq 0V$			-20	
RECEIVER						
Input Current (A and B)	$I_{A, B}$	DI = V_{CC} , $V_{CC} = \text{GND}$ or +5V	$V_{IN} = +12V$		250	μA
			$V_{IN} = -7V$	-200		
Receiver Differential Threshold Voltage	V_{TH}	$-7V \leq V_{CM} \leq +12V$	-200		+200	mV
Receiver Input Hysteresis	ΔV_{TH}	$V_A + V_B = 0V$		25		mV
Output-High Voltage	V_{OH}	$I_O = -1.6\text{mA}$, $V_A - V_B > V_{TH}$		$V_{CC} - 1.5$		V
Output-Low Voltage	V_{OL}	$I_O = 1\text{mA}$, $V_A - V_B < -V_{TH}$			0.4	V
Tri-State Output Current at Receiver	I_{OZR}	$0V \leq V_O \leq V_{CC}$			± 1	μA
Receiver Input Resistance	R_{IN}	$-7V \leq V_{CM} \leq +12V$	48			k Ω
Receiver Output Short-Circuit Current	I_{OSR}	$0V \leq V_{RO} \leq V_{CC}$	± 7		± 95	mA

Electrical Characteristics (continued)(V_{CC} = +5V ±5%, T_A = T_{MIN} to T_{MAX}, unless otherwise noted. Typical values are at V_{CC} = +5V and T_A = +25°C.) (Note 1)

PARAMETER	SYMBOL	CONDITIONS	MIN	TYP	MAX	UNITS
POWER SUPPLY						
Supply Voltage	V _{CC}		4.75		5.25	V
Supply Current	I _{CC}	$\overline{\text{SHDN}} = 1, \overline{\text{RE}} = 0$, no load			4.5	mA
Shutdown Supply Current	$\overline{\text{I}}_{\text{SHDN}}$	$\overline{\text{SHDN}} = 0$			10	μA
ESD PROTECTION						
ESD Protection (A, B)		Air Gap Discharge IEC 61000-4-2 (MAX13487E)	±15			kV
		Human Body Model	±15			
ESD Protection (All Other Pins)		Human Body Model	±2			kV

Switching Characteristics—MAX13487E(V_{CC} = +5V ±5%, T_A = T_{MIN} to T_{MAX}, unless otherwise noted. Typical values are at V_{CC} = +5V and T_A = +25°C.)

PARAMETER	SYMBOL	CONDITIONS	MIN	TYP	MAX	UNITS
DRIVER						
Driver Propagation Delay	t _{DPLH}	R _L = 110Ω, C _L = 50pF, Figures 2 and 3	200		1000	ns
	t _{DPHL}		200		1000	
Driver Differential Output Rise or Fall Time	t _{HL}	R _L = 110Ω, C _L = 50pF, Figures 2 and 3	200		900	ns
	t _{LH}		200		900	
Maximum Data Rate			500			kbps
Driver Disable Delay	t _{DDD}	Figure 3			2500	ns
Driver Enable from Shutdown to Output High	t _{DZH(SHDN)}	Figure 4			5.5	μs
Driver Enable from Shutdown to Output Low	t _{DZL(SHDN)}	Figure 4			5.5	μs
Time to Shutdown	t _{SHDN}		50	340	700	ns
RECEIVER						
Receiver Propagation Delay	t _{RPLH}	C _L = 15pF, Figures 5 and 6			80	ns
	t _{RPHL}				80	
Receiver Output Skew	t _{RSKEW}	C _L = 15pF, Figure 6			13	ns
Maximum Data Rate			500			kbps
Receiver Enable to Output High	t _{RZH}	Figure 7			50	ns
Receiver Enable to Output Low	t _{RZL}	Figure 7			50	ns
Receiver Disable Time from High	t _{RHZ}	Figure 7			50	ns
Receiver Disable Time from Low	t _{RLZ}	Figure 7			50	ns
Receiver Enable from Shutdown to Output High	t _{RZH(SHDN)}	Figure 8			2200	ns

Switching Characteristics—MAX13487E (continued)(V_{CC} = +5V ±5%, T_A = T_{MIN} to T_{MAX}, unless otherwise noted. Typical values are at V_{CC} = +5V and T_A = +25°C.)

PARAMETER	SYMBOL	CONDITIONS	MIN	TYP	MAX	UNITS
Receiver Enable from Shutdown to Output Low	t _{RZL} (SHDN)	Figure 8			2200	ns
Receiver Enable Delay	t _{RED}	Figure 3			70	ns
Time to Shutdown	t _{SHDN}		50	340	700	ns

Switching Characteristics—MAX13488E(V_{CC} = +5V ±5%, T_A = T_{MIN} to T_{MAX}, unless otherwise noted. Typical values are at V_{CC} = +5V and T_A = +25°C.)

PARAMETER	SYMBOL	CONDITIONS	MIN	TYP	MAX	UNITS
DRIVER						
Driver Propagation Delay	t _{DPLH}	R _L = 110Ω, C _L = 50pF, Figures 2 and 3			50	ns
	t _{DPHL}				50	
Driver Differential Output Rise or Fall Time	t _{HL}	R _L = 110Ω, C _L = 50pF, Figures 2 and 3			15	ns
	t _{LH}				15	
Maximum Data Rate			16			Mbps
Driver Disable Delay	t _{DDD}	Figure 3			70	ns
Driver Enable from Shutdown to Output High	t _{DZH} (SHDN)	Figure 4			2.2	μs
Driver Enable from Shutdown to Output Low	t _{DZL} (SHDN)	Figure 4			2.2	μs
Time to Shutdown	t _{SHDN}		50	340	700	ns
RECEIVER						
Receiver Propagation Delay	t _{RPLH}	C _L = 15pF, Figures 5 and 6			80	ns
	t _{RPHL}				80	
Receiver Output Skew	t _{RSKEW}	C _L = 15pF, Figure 6			13	ns
Maximum Data Rate			16			Mbps
Receiver Enable to Output High	t _{RZH}	Figure 7			50	ns
Receiver Enable to Output Low	t _{RZL}	Figure 7			50	ns
Receiver Disable Time from High	t _{RHZ}	Figure 7			50	ns
Receiver Disable Time from Low	t _{RLZ}	Figure 7			50	ns
Receiver Enable from Shutdown to Output High	t _{RZH} (SHDN)	Figure 8			2200	ns

Switching Characteristics—MAX13488E (continued)

(V_{CC} = +5V ±5%, T_A = T_{MIN} to T_{MAX}, unless otherwise noted. Typical values are at V_{CC} = +5V and T_A = +25°C.)

PARAMETER	SYMBOL	CONDITIONS	MIN	TYP	MAX	UNITS
Receiver Enable from Shutdown to Output Low	t _{RZL} (SHDN)	Figure 8			2200	ns
Receiver Enable Delay	t _{RED}	Figure 3			70	ns
Time to Shutdown	t _{SHDN}		50	340	700	ns

Note 1: All currents into the device are positive. All currents out of the device are negative. All voltages referred to device ground, unless otherwise noted.

Note 2: This is a differential voltage from A to B that the driving device must see on the bus to disable its driver.

Note 3: The short-circuit output current applied to peak current just prior to foldback current limiting. The short-circuit foldback output current applies during current limiting to allow a recovery from bus contention.

Typical Operating Characteristics

(V_{CC} = +5.0V, T_A = +25°C, unless otherwise noted.)

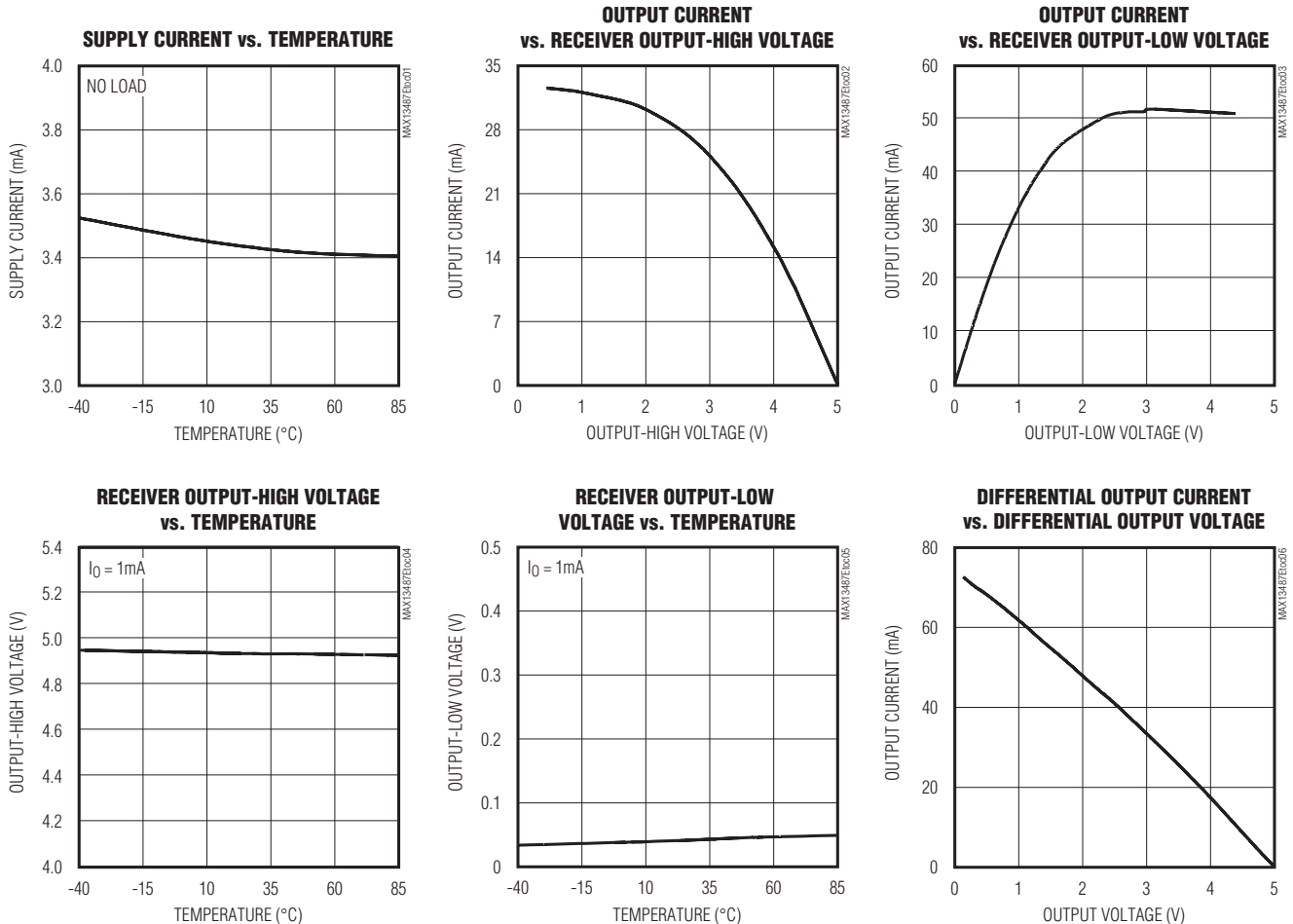

Typical Operating Characteristics (continued)

(V_{CC} = +5.0V, T_A = +25°C, unless otherwise noted.)

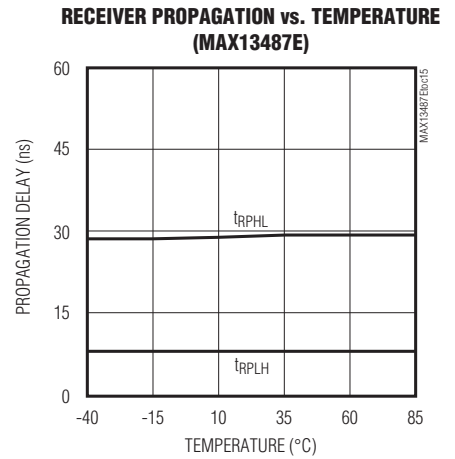
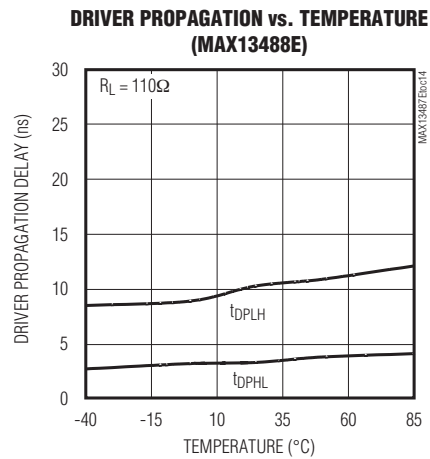
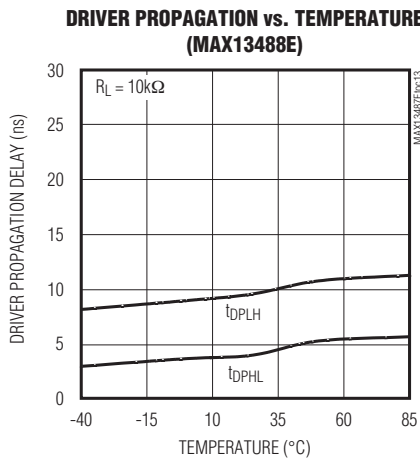
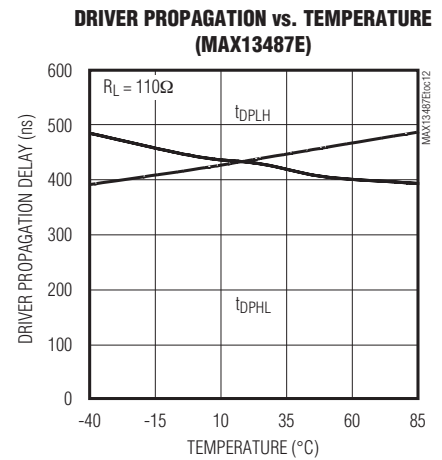
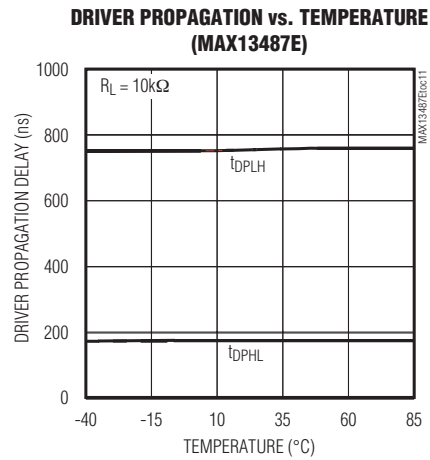
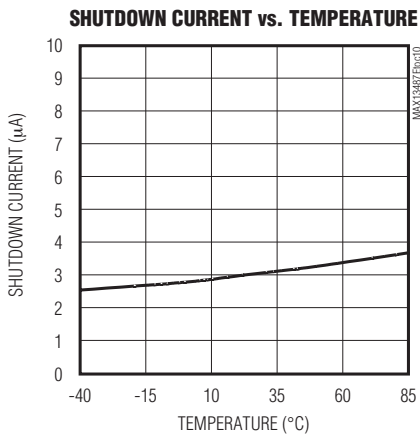
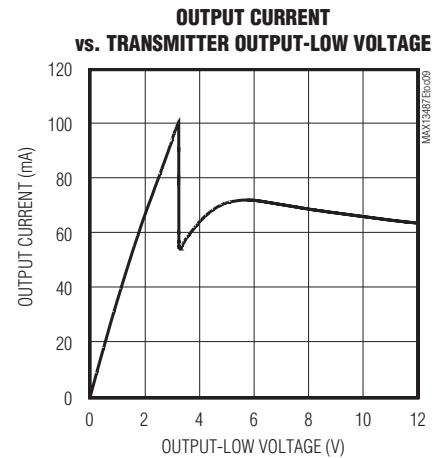
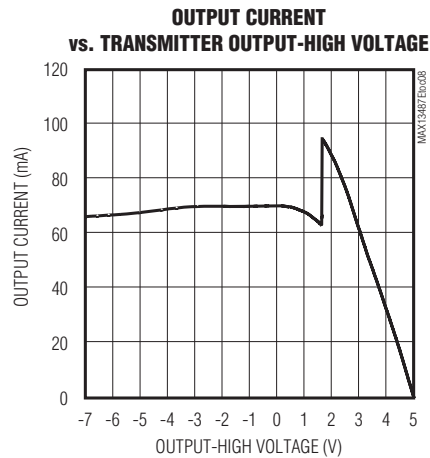
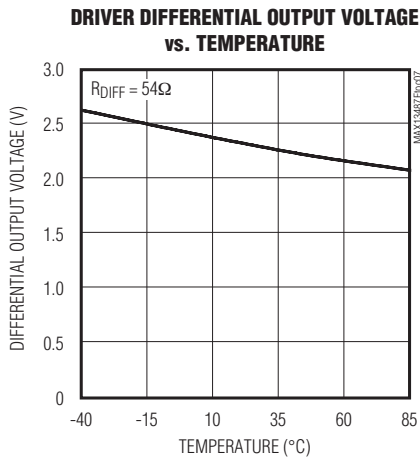

Typical Operating Characteristics (continued)

($V_{CC} = +5.0V$, $T_A = +25^\circ C$, unless otherwise noted.)

**RECEIVER PROPAGATION vs. TEMPERATURE
(MAX13488E)**

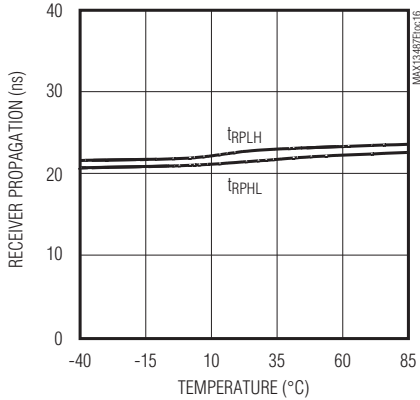

**DRIVER PROPAGATION (500kbps)
(MAX13487E)**

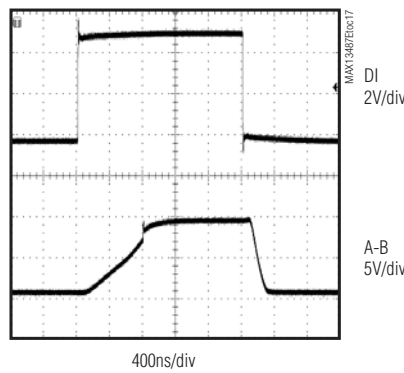

**DRIVER PROPAGATION (16Mbps)
(MAX13488E)**

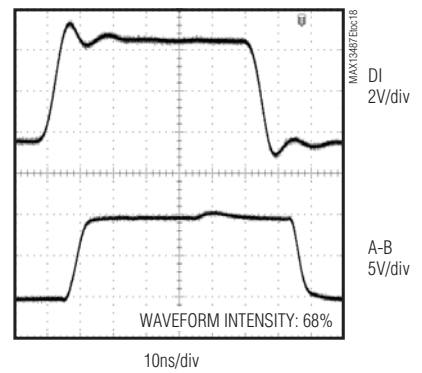

**RECEIVER PROPAGATION (16Mbps)
(MAX13488E)**

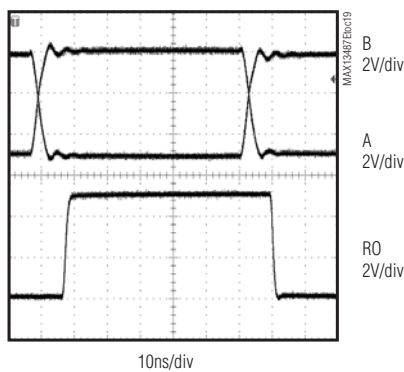

**DRIVING 16nF (19.2kbps)
(MAX13487E)**

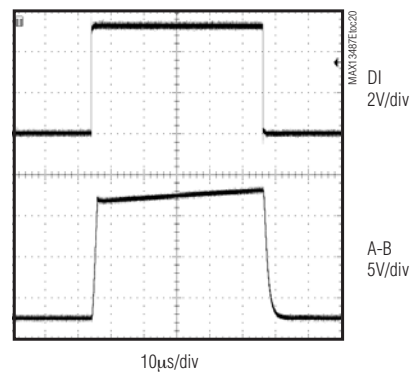

**DRIVING 16nF (19.2kbps)
(MAX13488E)**

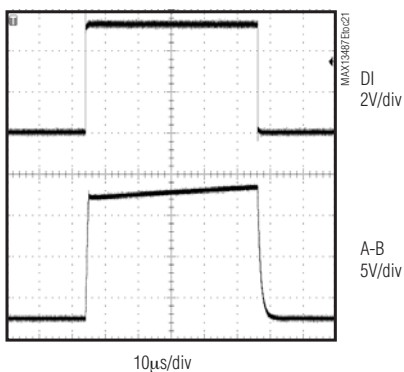

**DRIVING 16nF (750kbps)
(MAX13488E)**

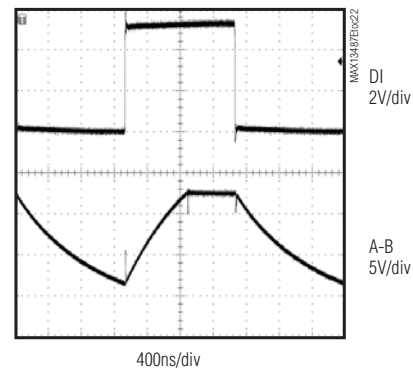

Test Circuits and Waveforms

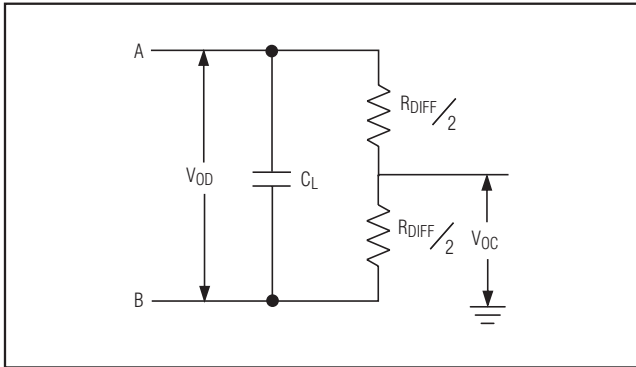

Figure 1. Driver DC Test Load

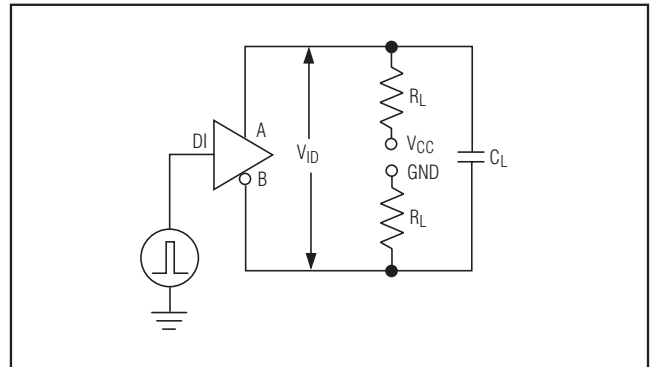

Figure 2. Driver-Timing Test Circuit

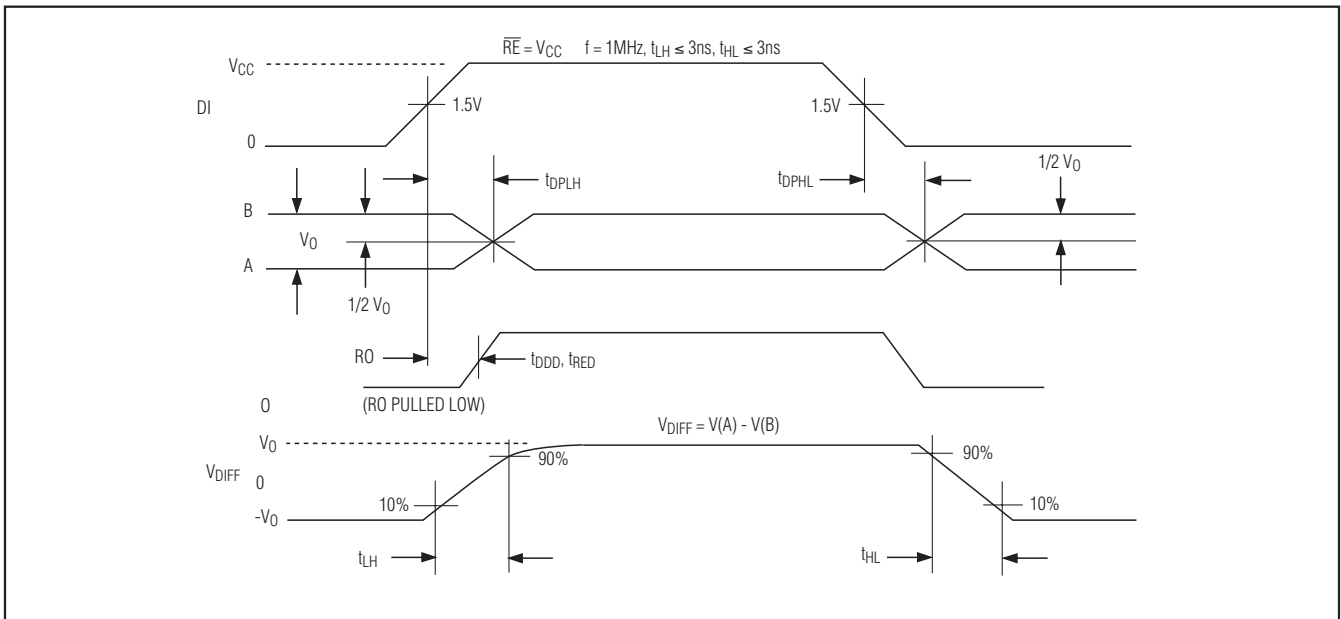

Figure 3. Driver Propagation Delays

Test Circuits and Waveforms (continued)

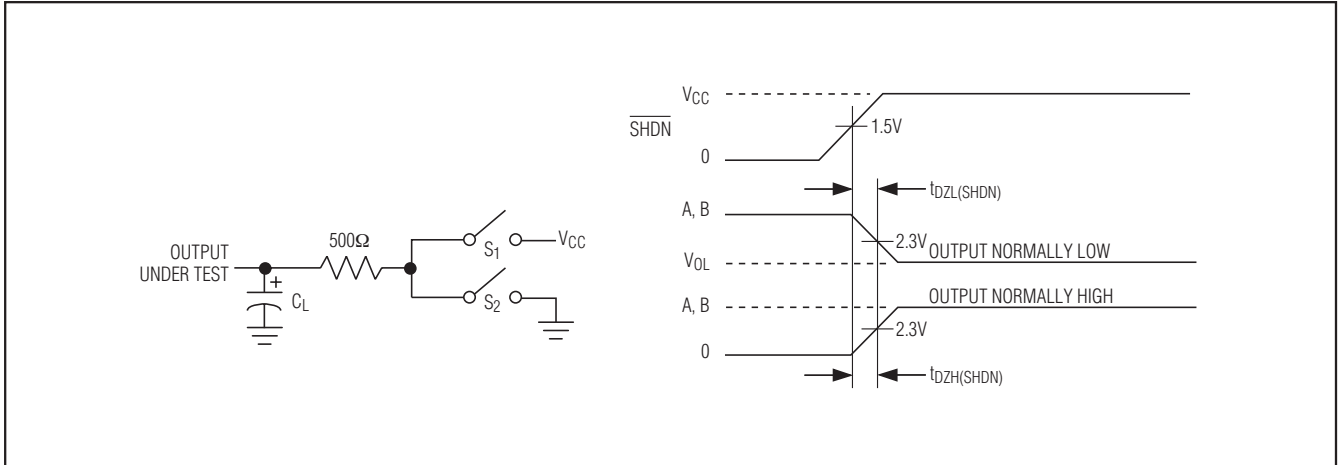

Figure 4. Driver Enable and Disable Times

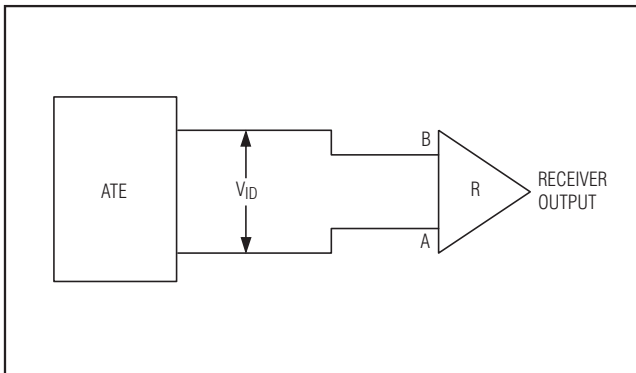

Figure 5. Receiver-Propagation-Delay Test Circuit

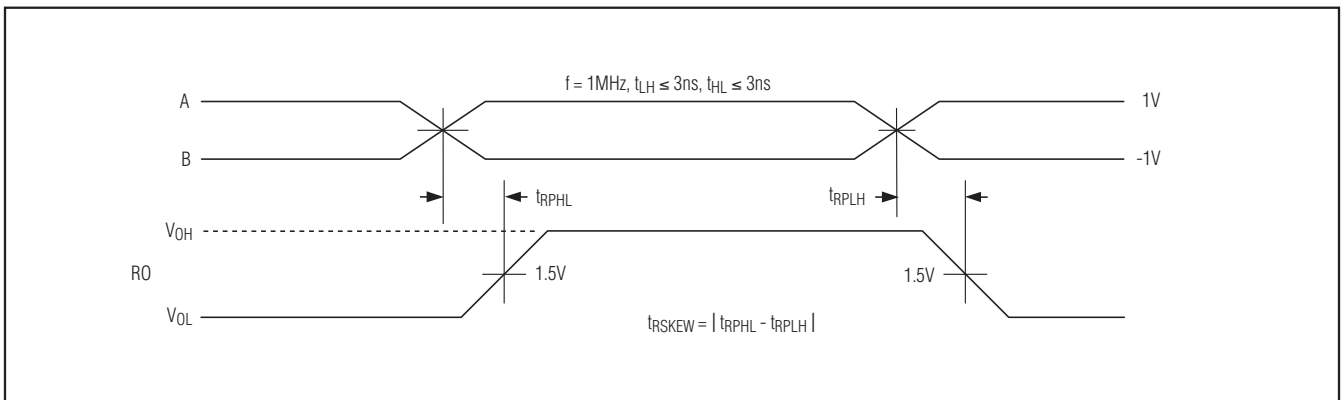

Figure 6. Receiver Propagation Delays

Test Circuits and Waveforms (continued)

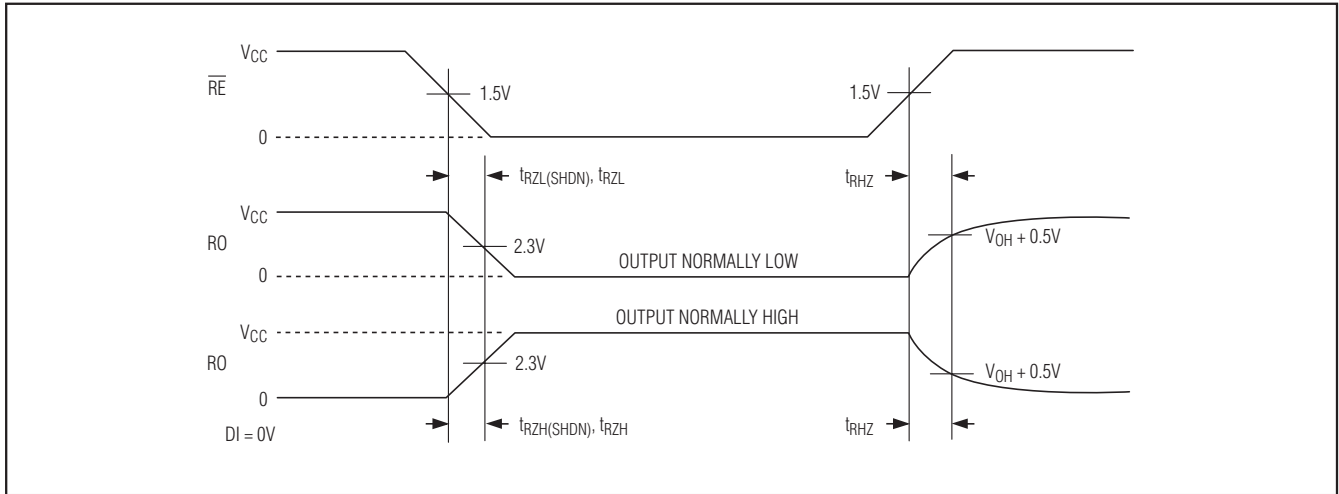

Figure 7. Receiver Enable and Disable Times

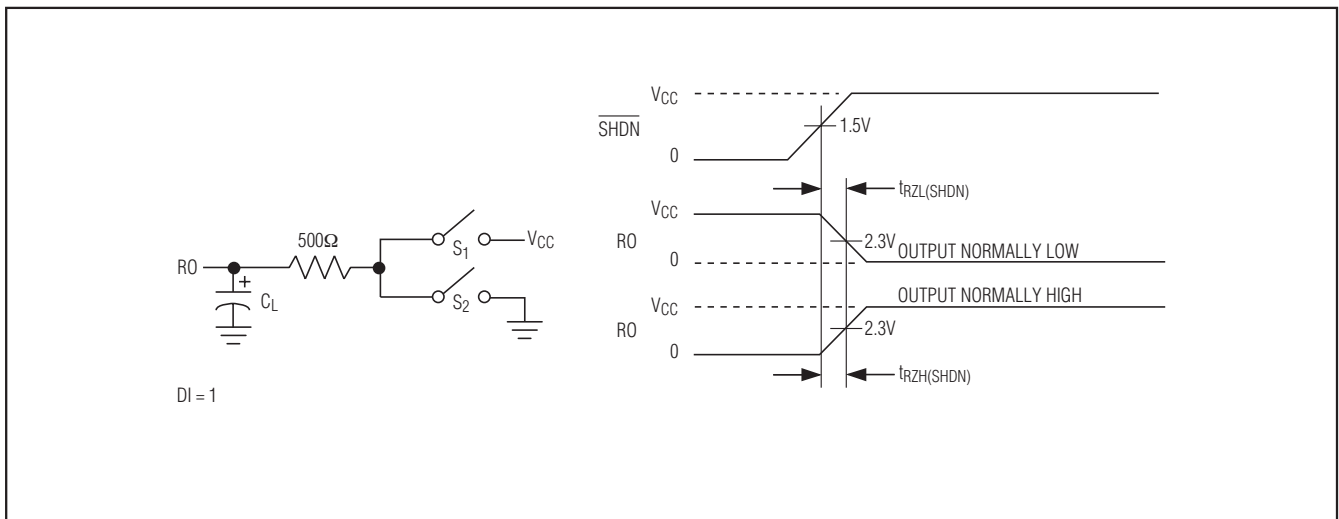

Figure 8. Receiver Enable Time from Shutdown

Pin Description

PIN	NAME	FUNCTION
1	RO	Receiver Output. When receiver is enabled and $V(A) - V(B) > +200\text{mV}$, RO is high. If $V(A) - V(B) < -200\text{mV}$, RO is low.
2	$\overline{\text{RE}}$	Receiver Output Enable. Drive $\overline{\text{RE}}$ low to enable the RO. Drive $\overline{\text{RE}}$ high to let the AutoDirection circuit control the receiver. $\overline{\text{RE}}$ is a hot-swap input (see the <i>Hot-Swap Capability</i> section for more details).
3	$\overline{\text{SHDN}}$	Shutdown. Drive $\overline{\text{SHDN}}$ high to let the device operate in normal operation. Drive $\overline{\text{SHDN}}$ low to put the part in shutdown.
4	DI	Driver Input. Drive DI low to force noninverting output low and inverting output high. Drive DI high to force noninverting output high and inverting output low. DI is an input to the internal state machine that automatically enables and disables the driver. See the <i>Function Tables</i> and <i>General Description</i> for more information. DI is a hot-swap input (see the <i>Hot-Swap Capability</i> section for more details).
5	GND	Ground
6	A	Noninverting Receiver Input and Noninverting Driver Output
7	B	Inverting Receiver Input and Inverting Driver Output
8	V _{CC}	Positive Supply, V _{CC} = +5V ±5%. Bypass V _{CC} to GND with a 0.1µF capacitor.

Function Tables

TRANSMITTING					
INPUTS			OUTPUTS		
$\overline{\text{SHDN}}$	DI	A-B > V _{DT}	ACTION	A	B
1	0	X	Turn driver ON	0	1
1	1	False	If driver was OFF, keep it OFF	HIGH IMPEDANCE	HIGH IMPEDANCE
1	1	False	If driver was ON, keep it ON	1	0
1	1	True	Turn driver OFF	HIGH IMPEDANCE	HIGH IMPEDANCE
0	X	X	X	SHUTDOWN	

RECEIVING					
INPUTS				OUTPUT	
$\overline{\text{SHDN}}$	$\overline{\text{RE}}$	A-B	DRIVER STATE	RECEIVER STATE	RO
1	0	≥+200mV	X	ON	1
1	0	≤-200mV	X	ON	0
1	1	X	ON	OFF	HIGH IMPEDANCE
1	1	≥+200mV	OFF	ON	1
1	1	≤-200mV	OFF	ON	0
0	X	X	X	X	SHUTDOWN

X = Don't care, shutdown mode, driver, and receiver outputs are in high impedance.

Detailed Description

The MAX13487E/MAX13488E half-duplex, high-speed transceivers for RS-485/RS-422 communication contain one driver and one receiver. The MAX13487E/MAX13488E feature a hot-swap capability allowing line insertion without erroneous data transfer (see the *Hot-Swap Capability* section). The MAX13487E features reduced slew-rate drivers that minimize EMI and reduce reflections caused by improperly terminated cables, allowing error-free transmission up to 500kbps. The MAX13488E driver slew rate is not limited, making data throughput of up to 16Mbps possible.

AutoDirection Circuitry

Internal circuitry in the MAX13487E/MAX13488E, in conjunction with an external pullup resistor on A and pulldown resistor on B (see *Typical Application Circuit*), act to automatically disable or enable the driver and receiver to keep the bus in the correct state. This AutoDirection circuitry consists of a state machine and an additional receive comparator that determines whether this device is trying to drive the bus, or another node on the network is driving the bus.

The internal state machine has two inputs:

- DI
- The current state of A-B (determined by a dedicated differential comparator)

The state machine also has two outputs:

- DRIVER_ENABLE—Internal signal that enables and disables the driver
- RECEIVER_ENABLE—Internal signal that is the inverse of the DRIVER_ENABLE signal, but it can be overridden by an external pin

When DI is low, the device always drives the bus low. When DI is high, the device drives the bus for a short time, then disables the driver and allows the external pullup/pulldown resistors to hold the bus in the high state ($A-B > 200\text{mV}$). During each low-to-high transition of DI, the driver stays enabled until $(A-B) > V_{DT}$, and then disables the driver, letting the pullup/pulldown resistors hold the A and B lines in the correct state.

Pullup and Pulldown Resistors

The pullup and pulldown resistors on the A and B lines are required for proper operation of the device although their exact value is not critical. They function to hold the bus in the high state ($A-B > 200\text{mV}$) following a low-to-high transition. Sizing of these resistors is determined in the same way as when using any other RS-485 driver and depends on how the line is terminated and how many nodes are on the bus. The most

important factor when sizing these resistors is to guarantee that the idle voltage on the bus (A-B) is greater than 200mV in order to remain compatible with standard RS-485 receiver thresholds.

Idle State

When not transmitting data, the MAX13487E/MAX13488E require the DI input be driven high to remain in the idle state. A conventional RS-485 transceiver has DE and \overline{RE} inputs that are used to enable and disable the driver and receiver. However, the MAX13487E/MAX13488E does not have a DE input, and instead uses an internal state machine to enable and disable the drivers. DI must be driven high in order to go to the idle state.

Hot-Swap Capability

Hot-Swap Inputs

When circuit boards are inserted into a hot or powered back plane, differential disturbances to the data bus can lead to data errors. Upon initial circuit-board insertion, the data communication processor undergoes its own power-up sequence. During this period, the processor's logic-output drivers are high impedance and are unable to drive the DI and \overline{RE} inputs of these devices to a defined logic level. Leakage currents up to $\pm 10\mu\text{A}$ from the high-impedance state of the processor's logic drivers could cause standard CMOS enable inputs of a transceiver to drift to an incorrect logic level. Additionally, parasitic circuit-board capacitance could cause coupling of V_{CC} or GND to the enable inputs. Without the hot-swap capability, these factors could improperly enable the transceiver's driver.

To overcome both these problems, two different pullup switches (strong and weak) are turned on during the power-up. When V_{CC} rises, an internal power-up signal enables a strong pullup circuit. It holds DI and \overline{RE} high with 1mA for 15 μs . Once the timeout is expired, this strong pullup is switched off. A weak pullup (100 μA) remains active to overcome leakage on the pin. This second weak pullup disappears as soon as the microcontroller forces a low state on these pins. Therefore, in normal operation (after the first activation), these pins can be considered as high-impedance pins (CMOS inputs) without any pullup circuitry.

The AutoDirection state machine is initialized, forcing the driver disabled. The receiver is enabled in AutoDirection mode.

Hot-Swap Input Circuitry

The enable inputs feature hot-swap capability. At the input there are two pMOS devices, M1 and M2 (Figure 9). When V_{CC} ramps from zero, an internal 15 μs timer turns

on M2 and sets the SR latch, which also turns on M1. Transistors M2, a 1.5mA current source, and M1, a 500 μ A current source, pull \overline{RE} to V_{CC} through a 5k Ω resistor. M2 is designed to pull \overline{RE} to the disabled state against an external parasitic capacitance up to 100pF that can drive \overline{RE} high. After 15 μ s, the timer deactivates M2 while M1 remains on, holding DI high against three-state leakages that can drive \overline{RE} low. M1 remains on until an external source overcomes the required input current. At this time, the SR latch resets and M1 turns off. When M1 turns off, \overline{RE} reverts to a standard, high-impedance CMOS input. Whenever V_{CC} drops below 1V, the hot-swap input is reset. DI has similar hot-swap circuitry.

± 15 kV ESD Protection

As with all Maxim devices, ESD-protection structures are incorporated on all pins to protect against electrostatic discharges encountered during handling and assembly. The driver outputs and receiver inputs of the MAX13487E/MAX13488E have extra protection against static electricity. Maxim's engineers have developed state-of-the-art structures to protect these pins against ESD of ± 15 kV without damage. The ESD structures withstand high ESD in all states: normal operation, shut-down, and powered down. After an ESD event, the MAX13487E/MAX13488E keep working without latchup or damage.

ESD protection can be tested in various ways. The transmitter outputs and receiver inputs of the MAX13487E/MAX13488E are characterized for protection to the following limits:

- ± 15 kV using the Human Body Model
- ± 15 kV using the Air Gap Discharge Method specified in IEC 61000-4-2 (MAX13487E only)

ESD Test Conditions

ESD performance depends on a variety of conditions. Contact Maxim for a reliability report that documents test setup, test methodology, and test results.

Human Body Model

Figure 10a shows the Human Body Model, and Figure 10b shows the current waveform it generates when discharged into a low impedance. This model consists of a 100pF capacitor charged to the ESD voltage of interest, which is then discharged into the test device through a 1.5k Ω resistor.

IEC 61000-4-2

The IEC 61000-4-2 standard covers ESD testing and performance of finished equipment. However, it does not specifically refer to integrated circuits. The MAX13487E/MAX13488E help you design equipment to

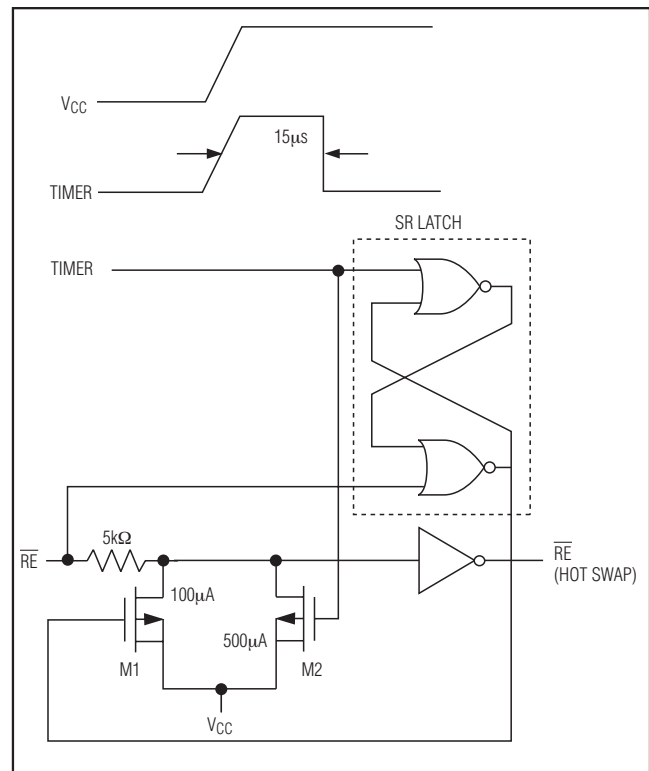

Figure 9. Simplified Structure of the Receiver Enable Pin (\overline{RE})

meet IEC 61000-4-2 without the need for additional ESD-protection components.

The major difference between tests done using the Human Body Model and IEC 61000-4-2 is higher peak current in IEC 61000-4-2 because series resistance is lower in the IEC 61000-4-2 model. Hence, the ESD withstand voltage measured to IEC 61000-4-2 is generally lower than that measured using the Human Body Model. Figure 10c shows the IEC 61000-4-2 model, and Figure 10d shows the current waveform for IEC 61000-4-2 ESD Contact Discharge test.

Machine Model

The machine model for ESD tests all pins using a 200pF storage capacitor and zero discharge resistance.

The objective is to emulate the stress caused when I/O pins are contacted by handling equipment during test and assembly. Of course, all pins require this protection, not just RS-485 inputs and outputs.

The Air-Gap test involves approaching the device with a charged probe. The Contact-Discharge method connects the probe to the device before the probe is energized.

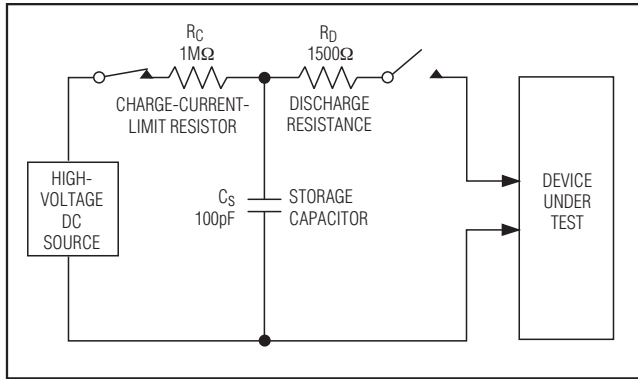

Figure 10a. Human Body ESD Test Model

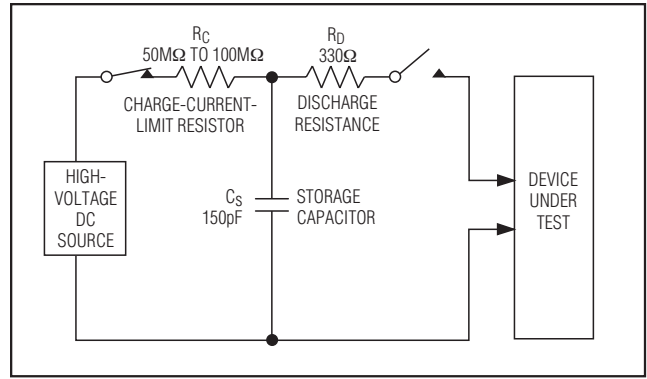

Figure 10c. IEC 61000-4-2 ESD Test Model

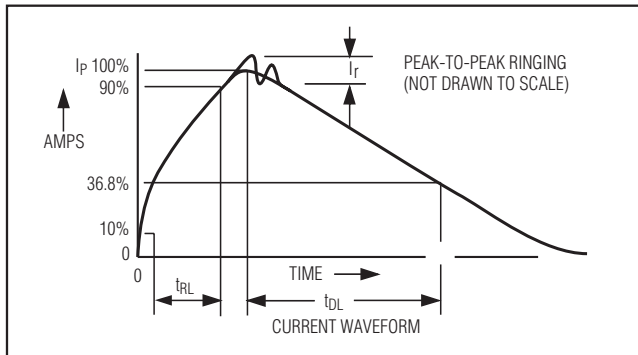

Figure 10b. Human Body Current Waveform

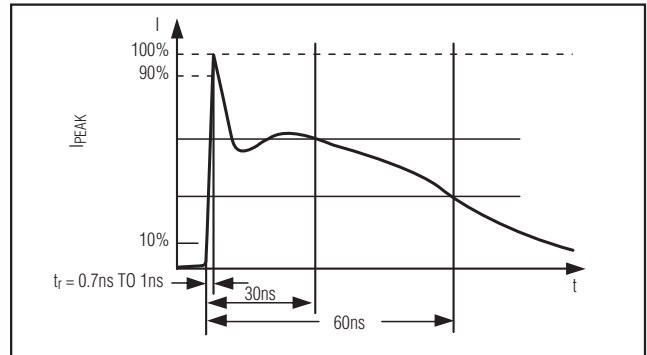

Figure 10d. IEC 61000-4-2 ESD Generator Current Waveform

Applications Information

128 Transceivers on the Bus

The standard RS-485 receiver input impedance is 12kΩ (1-unit load), and the standard driver can drive up to 32-unit loads. The MAX13487E/MAX13488E have a 1/4-unit load receiver input impedance (48kΩ), allowing up to 128 transceivers to be connected in parallel on one communication line. Any combination of these devices, as well as other RS-485 transceivers with a total of 32-unit loads or fewer, can be connected to the line.

Reduced EMI and Reflections

The MAX13487E features reduced slew-rate drivers that minimize EMI and reduce reflections caused by improperly terminated cables, allowing error-free data transmission up to 500kbps.

Low-Power Shutdown Mode

Low-power shutdown mode is initiated by bringing SHDN low. In shutdown, the devices draw a maximum of 10μA of supply current.

The devices are guaranteed not to enter shutdown if SHDN is low for less than 50ns. If the inputs are in this state for at least 700ns, the devices are guaranteed to enter shutdown.

Enable times tZH and tZL (see the *Switching Characteristics* section) assume the devices were not in a low-power shutdown state. Enable times tZH(SHDN) and tZL(SHDN) assume the devices were in shutdown state. It takes drivers and receivers longer to become enabled from low-power shutdown mode (tZH(SHDN), tZL(SHDN)) than from driver/receiver-disable mode (tZH, tZL).

Line Length

The RS-485/RS-422 standard covers line lengths up to 4000ft.

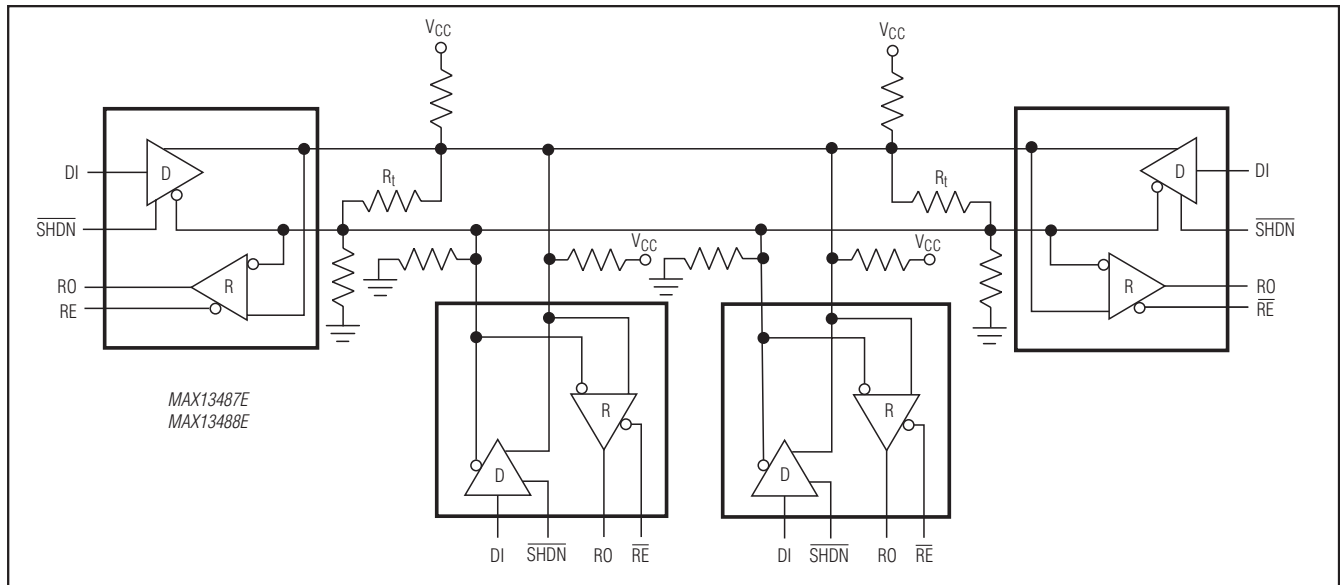

Figure 11. Typical Half-Duplex RS-485 Network

Typical Applications

The MAX13487E/MAX13488E transceivers are designed for half-duplex, bidirectional data communications on multipoint bus transmission lines. Figure 11 shows a typical network application. To minimize reflections, terminate the line at both ends in its characteristic impedance, and keep stub lengths off the main line as short as possible. The slow-rate-limited MAX13487E is more tolerant of imperfect termination.

Isolated RS-485 Interface

An isolated RS-485 interface electrically isolates different nodes on the bus to protect the bus from problems due to high common-mode voltages that exceed the RS-485 common-mode voltage range, conductive noise, and ground loops. The *Typical Application*

Circuit shows an isolated RS-485 interface using the MAX13487E/MAX13488E. The transceiver is powered separately from the controlling circuitry. The AutoDirection feature of the MAX13487E/MAX13488E (see the *AutoDirection Circuitry* section), replaces an external relay allowing faster switching speeds, no contact bounce, better reliability, and better electrical isolation. The MAX13487E/MAX13488E only require two optocouplers to electrically isolate the transceiver.

Chip Information

PROCESS: BiCMOS

Pin Configuration/Typical Application Circuit

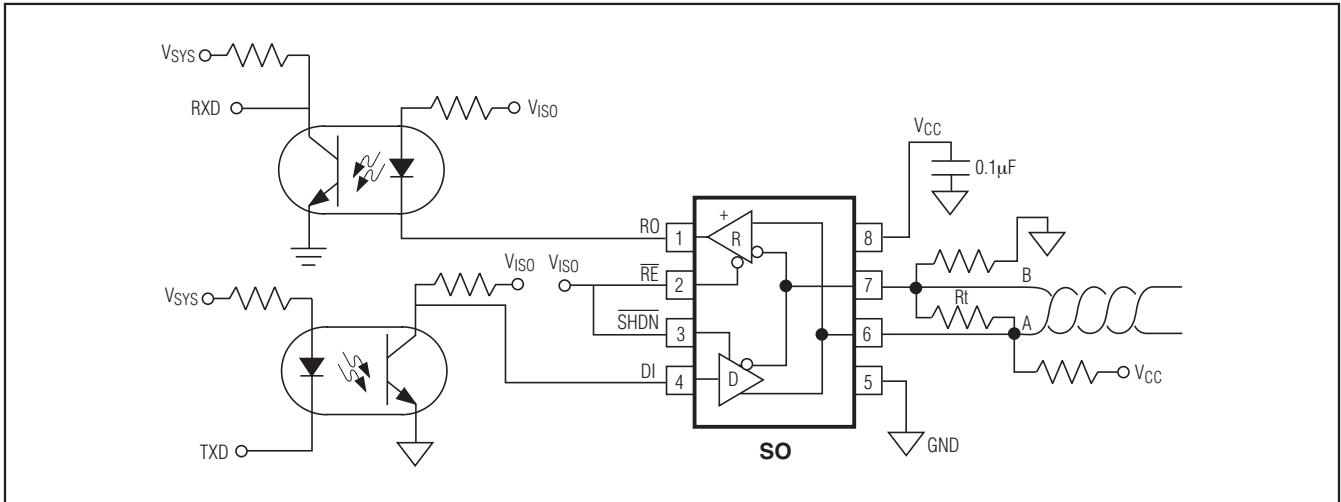

Package Information

For the latest package outline information and land patterns (footprints), go to www.maximintegrated.com/packages. Note that a "+", "#", or "-" in the package code indicates RoHS status only. Package drawings may show a different suffix character, but the drawing pertains to the package regardless of RoHS status.

PACKAGE TYPE	PACKAGE CODE	OUTLINE NO.	LAND PATTERN NO.
8 SO	S8+2	21-0041	90-0096

Revision History

REVISION NUMBER	REVISION DATE	DESCRIPTION	PAGES CHANGED
0	1/07	Initial release	—
1	2/15	Added the <i>Benefits and Features</i> section	1

For pricing, delivery, and ordering information, please contact Maxim Direct at 1-888-629-4642, or visit Maxim Integrated's website at www.maximintegrated.com.

Maxim Integrated cannot assume responsibility for use of any circuitry other than circuitry entirely embodied in a Maxim Integrated product. No circuit patent licenses are implied. Maxim Integrated reserves the right to change the circuitry and specifications without notice at any time. The parametric values (min and max limits) shown in the Electrical Characteristics table are guaranteed. Other parametric values quoted in this data sheet are provided for guidance.

Looking for pricing, stock, or lifecycle information?

Click below to explore more details on WIN SOURCE:

 [View MAX13487EESA+ on WIN SOURCE](#)

 [Maxim Integrated](#) Information

Optimize Your Supply Chain with WIN SOURCE Solutions

-  Global Sourcing Solution
-  Obsolete Management
-  Cost Control Management
-  Shortage Management
-  Alternative Solution
-  Excess Inventory Management