



# Three-Channel, High-Definition Video Filter

## General Description

The MAX11500 integrated three-channel high-definition (HD) video filter includes input video clamps and output buffers. This device is ideal for anti-aliasing and DAC smoothing video applications such as set-top boxes, hard-disk recorders (HDRs), DVD players, and personal video recorders.

The 6th-order channel filters have a typical -3dB bandwidth of 33MHz. Each channel has an output buffer with a gain of +6dB and can drive a full 2V<sub>P-P</sub> video signal into one standard 150Ω video load. These buffers can drive either an AC- or DC-coupled load such that the blanking level voltage after the backmatch resistor is less than 1V.

The video inputs feature a transparent clamp for AC- and DC-coupled input signals. If the input signal does not go below ground, the input clamp is inactive, thus enabling DAC outputs to be DC-coupled to the input.

The device operates from a single +5V supply, is offered in the upper commercial 0°C to +85°C temperature range, and is available in a small 8-pin SO package.

## Applications

High-Definition Set-Top Box Receivers  
 HD Television Sets  
 HD Recorders  
 DVD Players  
 Personal Video Recorders  
 Video-On-Demand

## Typical Operating Circuit

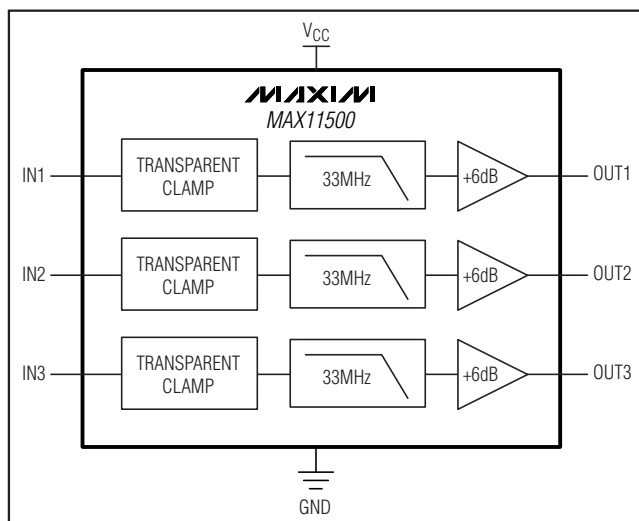

## Features

- ◆ Three-Channel 6th-Order Filter for High-Definition Video
- ◆ +6dB Output Buffers
- ◆ Transparent Input Clamps
- ◆ AC- or DC-Coupled Inputs
- ◆ AC- or DC-Coupled Outputs
- ◆ Output Buffers Drive One Standard 150Ω Video Load
- ◆ 12kV HBM ESD Protection on Outputs
- ◆ Single +5V Power Supply
- ◆ Small 8-Pin SO package

## Ordering Information

| PART         | TEMP RANGE   | PIN-PACKAGE | PKG CODE |
|--------------|--------------|-------------|----------|
| MAX11500USA+ | 0°C to +85°C | 8 SO        | S8-2     |

+Denotes a lead-free package.

## Pin Configuration

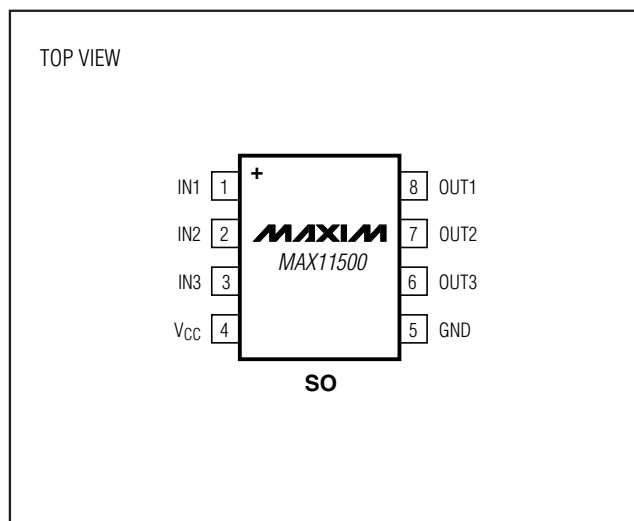

# Three-Channel, High-Definition Video Filter

## ABSOLUTE MAXIMUM RATINGS

V<sub>CC</sub> to GND .....-0.3V to +6V  
 All other pins to GND .....-0.3V to the lower of (V<sub>CC</sub> + 0.3V) and +6V  
 Continuous Power Dissipation (T<sub>A</sub> = +70°C)  
   8-Pin SO (derate 5.9mW/°C above +70°C).....470.6mW  
 Maximum Current into any Pin Except V<sub>CC</sub> and GND.....±50mA

Operating Temperature Range  
 MAX11500USA .....0°C to +85°C  
 Storage Temperature Range .....-65°C to +150°C  
 Lead Temperature (soldering, 10s) .....+300°C  
 Junction Temperature .....+150°C

*Stresses beyond those listed under "Absolute Maximum Ratings" may cause permanent damage to the device. These are stress ratings only, and functional operation of the device at these or any other conditions beyond those indicated in the operational sections of the specifications is not implied. Exposure to absolute maximum rating conditions for extended periods may affect device reliability.*

## ELECTRICAL CHARACTERISTICS

(V<sub>CC</sub> = +5V, R<sub>LOAD</sub> = 150Ω to GND, C<sub>IN</sub> = 0.1μF, T<sub>A</sub> = 0°C to +85°C, unless otherwise specified. All frequency response is relative to 100kHz.)

| PARAMETER                    | SYMBOL                | CONDITIONS   | MIN  | TYP  | MAX  | UNITS |
|------------------------------|-----------------------|--|------|------|------|-------|
| -1dB Bandwidth               | f <sub>1dB</sub>      | T <sub>A</sub> = +25°C   | 23   | 30   |      | MHz   |
| -3dB Bandwidth               | f <sub>3dB</sub>      |  |      | 33   |      | MHz   |
| Stopband Attenuation         | A <sub>SB</sub>       | f = 37.125MHz  |      | 6.5  |      | dB    |
|                              |                       | f = 44.25MHz   |      | 15.5 |      |       |
|                              |                       | f = 74.25MHz, T <sub>A</sub> = +25°C                               | 32   | 48   |      |       |
| Low-Frequency Gain           | A <sub>V</sub>        |  | 5.4  | 6.0  | 6.6  | dB    |
| Low-Frequency Gain Matching  | A <sub>V(MATCH)</sub> |  |      | 0.01 |      | dB    |
| Input Voltage Range          | V <sub>IN</sub>       | Referenced to GND if DC-coupled                                    |      | 1.7  |      | V     |
| Total Harmonic Distortion    | THD                   | V <sub>OUT</sub> = 1.4V <sub>P-P</sub> , f = 10MHz                 |      | 0.15 |      | %     |
|                              |                       | V <sub>OUT</sub> = 1.4V <sub>P-P</sub> , f = 15MHz                 |      | 0.2  |      |       |
|                              |                       | V <sub>OUT</sub> = 1.4V <sub>P-P</sub> , f = 22MHz                 |      | 0.8  |      |       |
| Channel-to-Channel Crosstalk | X <sub>TALK</sub>     | f = 1MHz   |      | -72  |      | dB    |
| Signal-to-Noise Ratio        | SNR                   | Peak signal (2V <sub>P-P</sub> ) to RMS noise, f = 100kHz to 30MHz |      | 68   |      | dB    |
| Group Delay                  | t <sub>g</sub>        | f = 100kHz   |      | 25   |      | ns    |
| Group-Delay Deviation        | Δt <sub>g</sub>       | f = 100kHz to 26MHz  |      | 8    |      | ns    |
| Supply Voltage Range         | V <sub>CC</sub>       |  | 4.75 | 5    | 5.25 | V     |
| Supply Current               | I <sub>CC</sub>       | No load  |      | 24   | 38   | mA    |

**Note 1:** All devices are 100% production tested at T<sub>A</sub> = +25°C.

# Three-Channel, High-Definition Video Filter

## Typical Operating Characteristics

( $V_{CC} = +5V$ , outputs AC-coupled with  $220\mu F$ ,  $R_{LOAD} = 150\Omega$  to GND,  $C_{IN} = 0.1\mu F$ ,  $T_A = +25^\circ C$ . All frequency response is relative to 100kHz.)

**MAX11500**

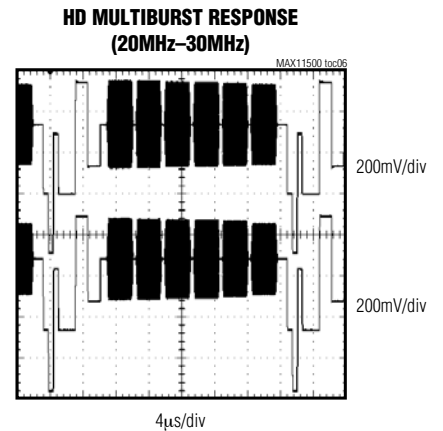
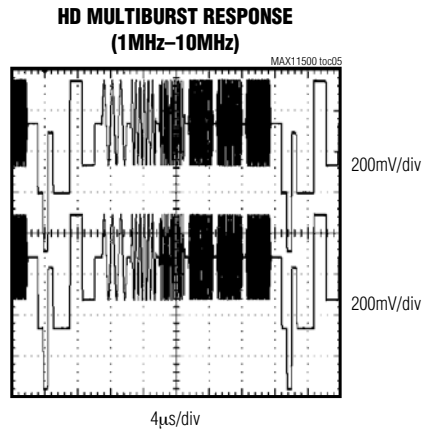
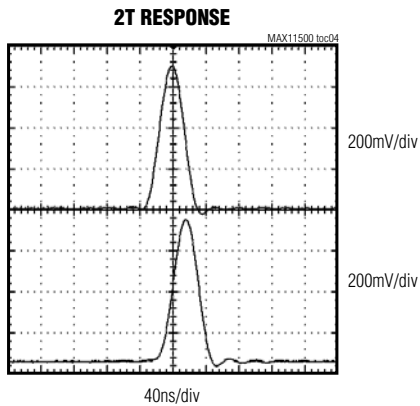
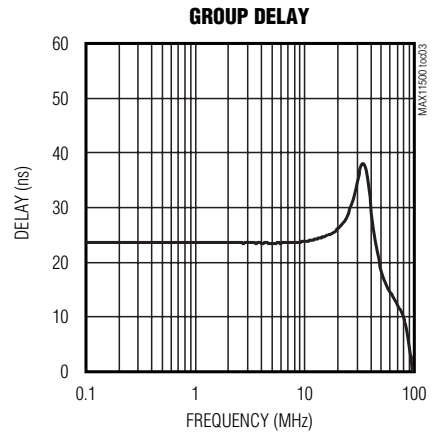
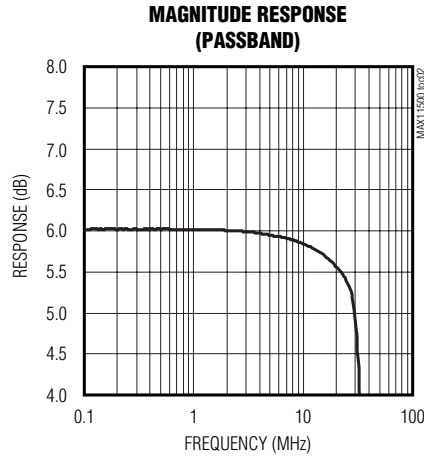
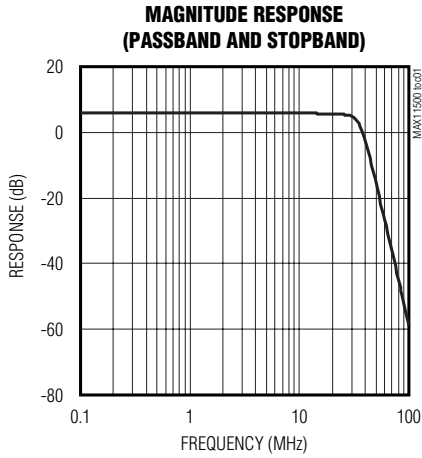

# Three-Channel, High-Definition Video Filter

## Pin Description

| PIN | NAME | FUNCTION   |
|-----|------|--|
| 1   | IN1  | Video Input Channel 1                                      |
| 2   | IN2  | Video Input Channel 2                                      |
| 3   | IN3  | Video Input Channel 3                                      |
| 4   | VCC  | Power Supply. Bypass to GND with 0.1µF and 1µF capacitors. |
| 5   | GND  | Ground   |
| 6   | OUT3 | Video Output Channel 3                                     |
| 7   | OUT2 | Video Output Channel 2                                     |
| 8   | OUT1 | Video Output Channel 1                                     |

## Detailed Description

The MAX11500 integrates three high-definition (HD) video filters, each with a transparent input clamp, a 6th-order lowpass filter with a -3dB bandwidth of 33MHz, and an output stage with a gain of 2V/V. The output signal is offset by typically 550mV to optimize driver performance.

$$V_{OUT} = 2 \times V_{IN} + 0.55V$$

Typical voltage waveforms are shown in Figures 1 and 2.

### Transparent Clamps

All inputs feature a transparent clamp that allows either AC- or DC-coupling of the inputs. The clamp remains inactive while the input signal is above ground, offering true DC input coupling. If the signal goes below ground, as is the case if it is AC-coupled, the clamp sets the sync tip close to the ground level.

### Input Coupling

The choice to AC- or DC-couple the input depends on the video source. Many DACs have a current output and are terminated to ground with a resistor; such signals can be conveniently DC-coupled. In cases where the DC level of the video signal is unknown or outside of the specified input range of the MAX11500, such signals require AC-coupling. Examples of the latter are SCART inputs and DACs terminated to VCC.

### DC-Coupled Inputs

If the input is DC-coupled, the voltage must remain above zero but not exceed the maximum input voltage of 1.7V (typical).

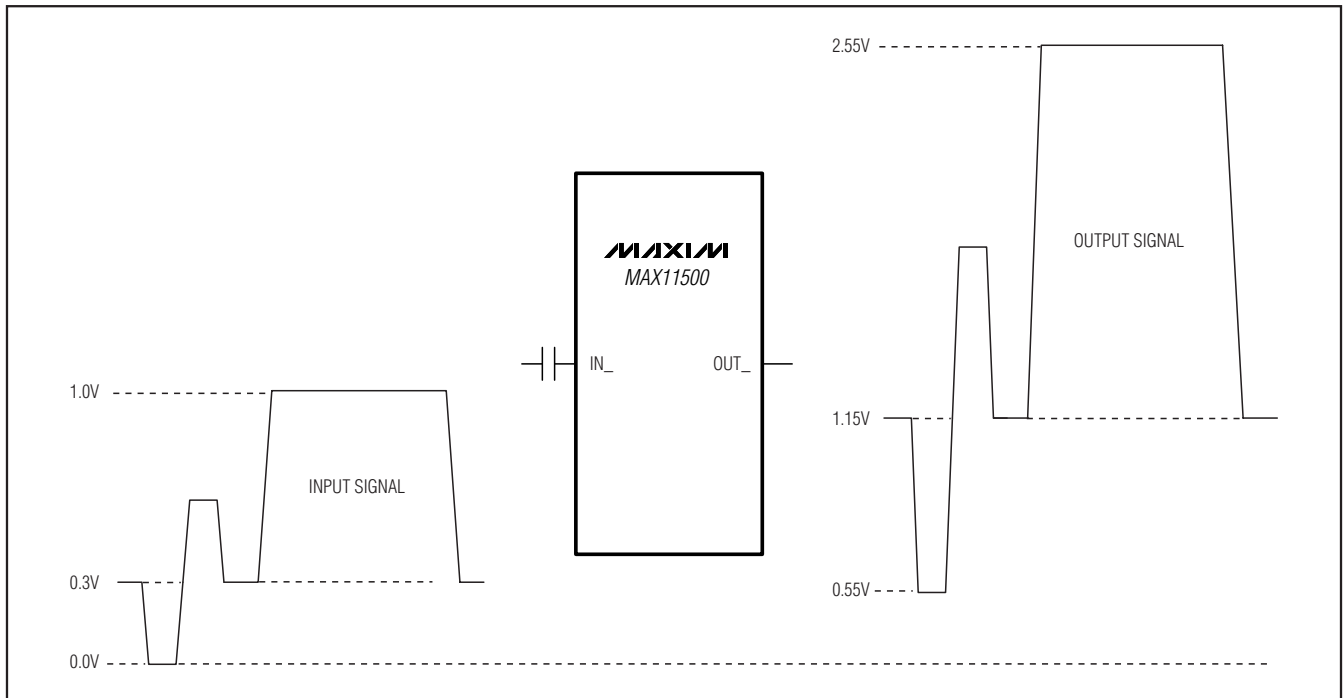

Figure 1. Typical AC-Coupled Signal

# Three-Channel, High-Definition Video Filter

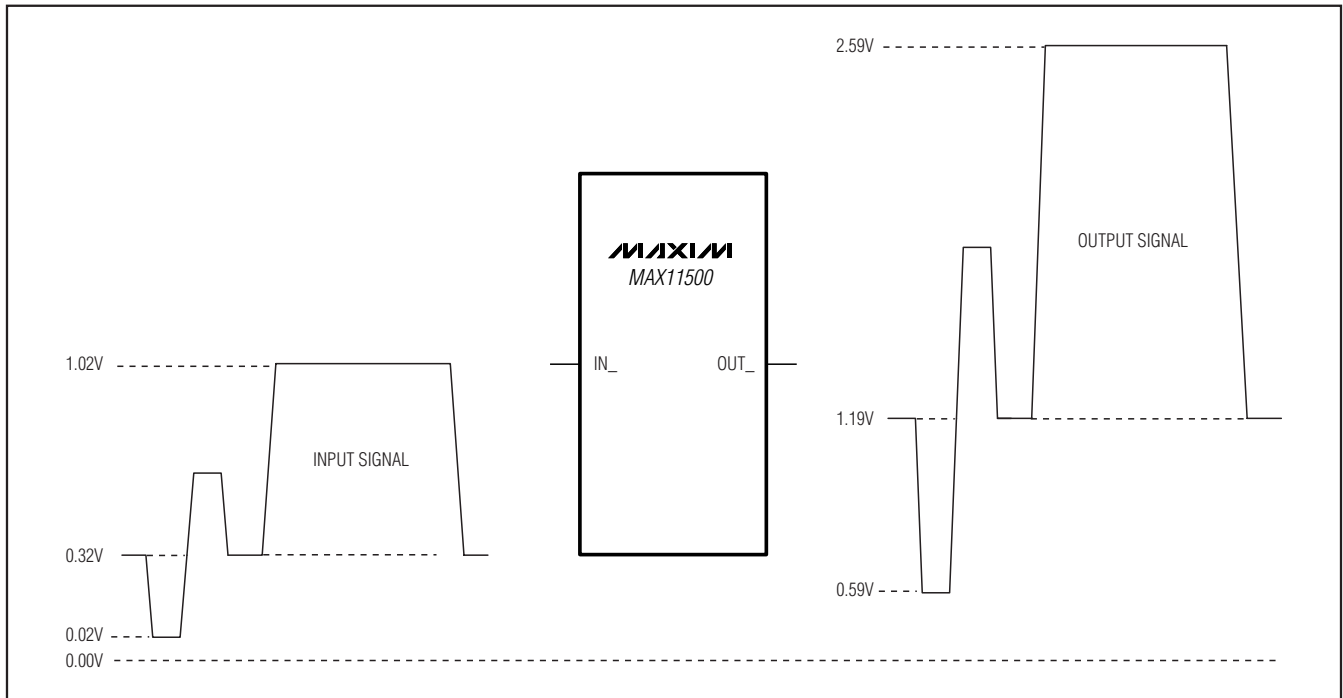

Figure 2. Typical DC-Coupled Signal

### AC-Coupled Inputs

If the input is AC-coupled, the transparent clamp will be active and sets the sync tip or the lowest voltage of the signal close to ground. This clamping behavior is appropriate for unipolar signals such as Y, R, G, or B with or without sync pulse (Figure 3).

For bipolar signals such as Pb, Pr signals, the AC-coupled inputs should be biased to a fixed DC voltage to ensure that the transparent clamp never turns on. A suitable network that biases the input to typically 0.59V is shown in Figure 4. The device has an input leakage current ( $I_L$ ) of typically  $0.5\mu\text{A}$  and thus the bias voltage is derived as follows:

$$V_B = \frac{R_2}{R_1 + R_2} (V_{CC} - I_L \times R_1)$$

### HD Filters

The internal filters are optimized to deliver a flat pass-band along with high stopband attenuation. The filter characteristic has been chosen to provide an excellent time-domain response with low overshoot. The typical -3dB frequency of 33MHz guarantees low attenuation in the passband, while at the same time allowing for a typical attenuation of -48dB at 74.25MHz.

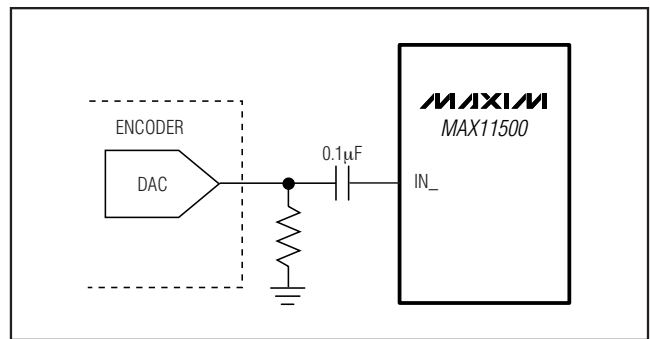

Figure 3. AC-Coupling for Unipolar Signals (Y, R, G, B)

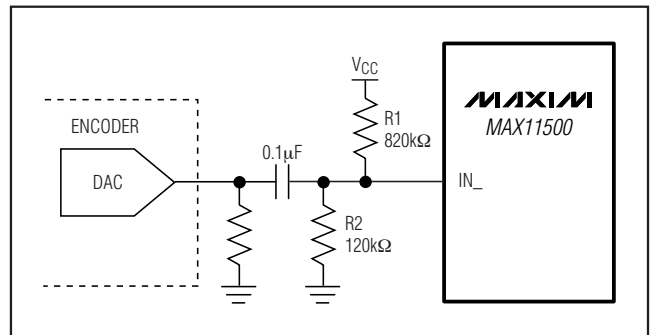

Figure 4. AC-Coupling for Bipolar Signals (Pb, Pr)

## Three-Channel, High-Definition Video Filter

### Output Buffer

The MAX11500 features output buffers with +6dB gain that drive a standard 150 $\Omega$  video load. A typical load consists of a 75 $\Omega$  backmatch resistor, an optional 220 $\mu$ F or larger coupling capacitor, and a 75 $\Omega$  termination resistor. The offset between input and output signals has been chosen such that the blanking level on the output is less than 1V after the backmatch resistor, thus meeting digital TV specifications. This allows the MAX11500 to drive video loads directly without using costly AC-coupling capacitors.

### Applications Information

#### Output Considerations

The MAX11500 outputs can be DC- or AC-coupled. The MAX11500, with +6dB gain, is typically connected to a 75 $\Omega$  series backmatch resistor followed by the video cable. If an AC connection is used, choose an AC-coupling capacitor value that ensures that the lowest frequency content in the video signal is passed and the field-time distortion is kept within desired limits. The selection of this value is a function of the input impedance and more importantly the input leakage of the circuit being driven. Common industry practice is to use a 220 $\mu$ F or larger capacitor.

The outputs of the MAX11500 are fully protected against a short circuit either to the ground or the positive supply of the device. The short-circuit protection circuitry limits the output current to typically 75mA per output. Shorting more than one output simultaneously may exceed the maximum package power dissipation.

### PCB Layout Recommendations

The device is thermally designed to operate with minimum copper. However, to help with heat dissipation, connect the power and ground traces to large copper areas if possible. Bypass V<sub>CC</sub> to GND with a 0.1 $\mu$ F capacitor and an additional 1 $\mu$ F capacitor in parallel for additional low-frequency decoupling. Using surface-mount capacitors reduces lead inductance and ensures that the impedance of the capacitors is low over a broad range of frequencies.

Place traces carrying video signals appropriately to avoid mutual coupling. If AC-coupling the inputs, place the input coupling capacitors as close as possible to the device and keep traces short to minimize parasitic capacitance and inductance. Doing so extends the performance to the uppermost frequency range possible with the MAX11500.

For a recommended PCB layout, refer to the MAX11500 EV kit data sheet.

# Three-Channel, High-Definition Video Filter

## Typical Operating Circuit

MAX11500

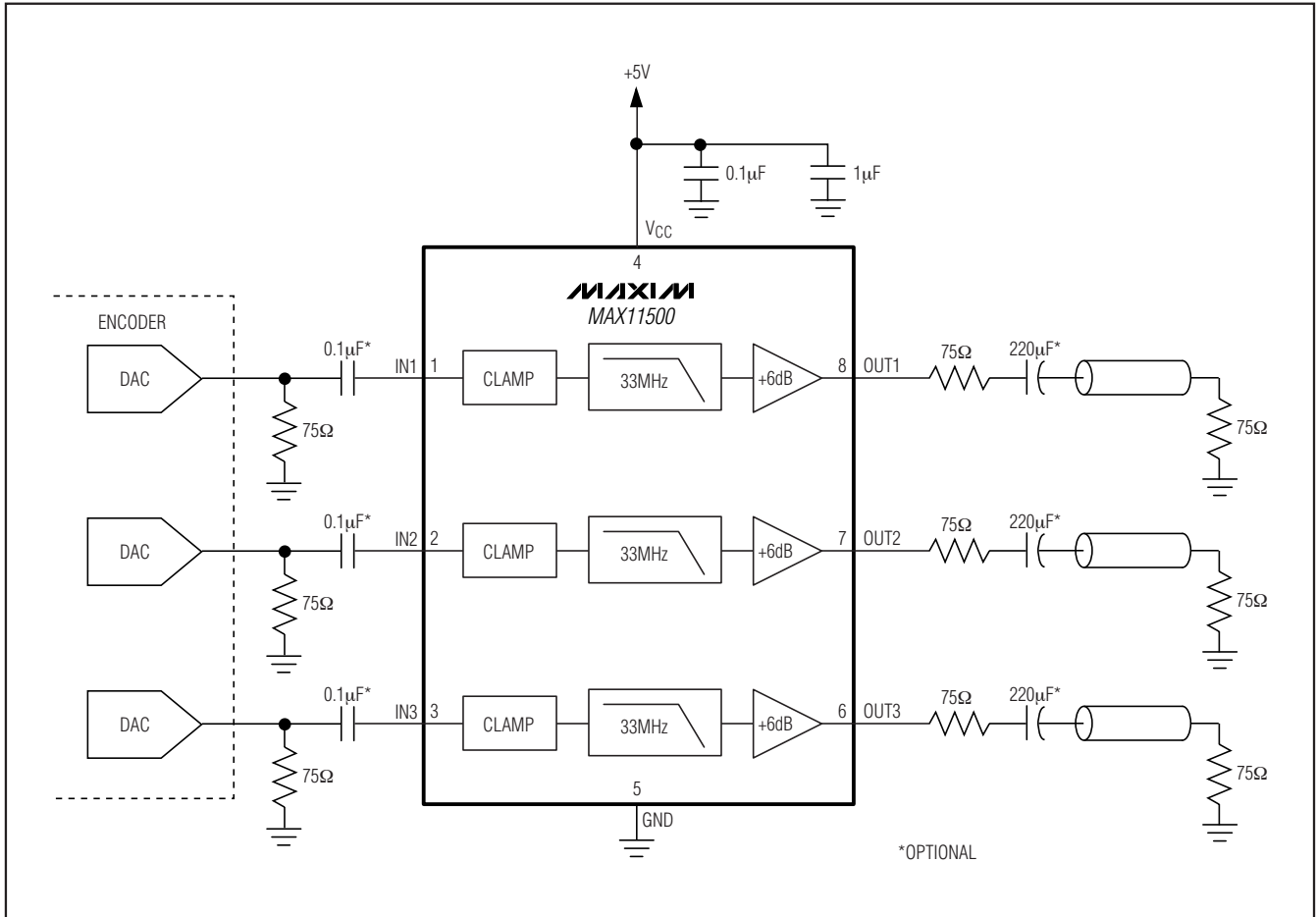

# Three-Channel, High-Definition Video Filter

## Package Information

(The package drawing(s) in this data sheet may not reflect the most current specifications. For the latest package outline information, go to [www.maxim-ic.com/packages](http://www.maxim-ic.com/packages).)

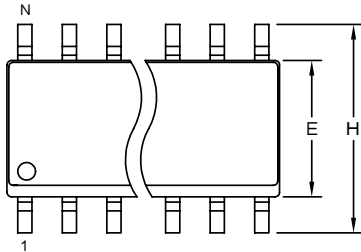

TOP VIEW

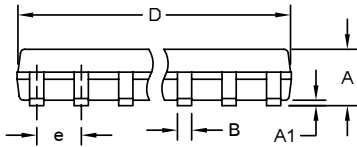

FRONT VIEW

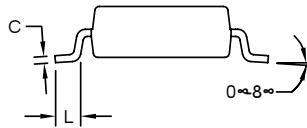

SIDE VIEW

**NOTES:**

1. D&E DO NOT INCLUDE MOLD FLASH.
2. MOLD FLASH OR PROTRUSIONS NOT TO EXCEED 0.15mm (.006").
3. LEADS TO BE COPLANAR WITHIN 0.10mm (.004").
4. CONTROLLING DIMENSION: MILLIMETERS.
5. MEETS JEDEC MS012.
6. N = NUMBER OF PINS.

| DIM | INCHES    |       | MILLIMETERS |      |
|-----|-----------|-------|-------------|------|
|     | MIN       | MAX   | MIN         | MAX  |
| A   | 0.053     | 0.069 | 1.35        | 1.75 |
| A1  | 0.004     | 0.010 | 0.10        | 0.25 |
| B   | 0.014     | 0.019 | 0.35        | 0.49 |
| C   | 0.007     | 0.010 | 0.19        | 0.25 |
| e   | 0.050 BSC |       | 1.27 BSC    |      |
| E   | 0.150     | 0.157 | 3.80        | 4.00 |
| H   | 0.228     | 0.244 | 5.80        | 6.20 |
| L   | 0.016     | 0.050 | 0.40        | 1.27 |

VARIATIONS:

| DIM | INCHES |       | MILLIMETERS |       | N  | MS012 |
|-----|--------|-------|-------------|-------|----|-------|
|     | MIN    | MAX   | MIN         | MAX   |    |       |
| D   | 0.189  | 0.197 | 4.80        | 5.00  | 8  | AA    |
| D   | 0.337  | 0.344 | 8.55        | 8.75  | 14 | AB    |
| D   | 0.386  | 0.394 | 9.80        | 10.00 | 16 | AC    |

|  |                                 |              |     |
|--|---------------------------------|--------------|-----|
| <b>DALLAS SEMICONDUCTOR</b>            |                                 | <b>MAXIM</b> |     |
| <small>PROPRIETARY INFORMATION</small> |                                 |              |     |
| TITLE:<br>PACKAGE OUTLINE, .150" SOIC  |                                 |              |     |
| APPROVAL                               | DOCUMENT CONTROL NO.<br>21-0041 | REV.<br>B    | 1/1 |



SOICN .EPS

Maxim cannot assume responsibility for use of any circuitry other than circuitry entirely embodied in a Maxim product. No circuit patent licenses are implied. Maxim reserves the right to change the circuitry and specifications without notice at any time.

8 \_\_\_\_\_ **Maxim Integrated Products, 120 San Gabriel Drive, Sunnyvale, CA 94086 408-737-7600**

## Looking for pricing, stock, or lifecycle information?

Click below to explore more details on WIN SOURCE:

-  [View MAX11500USA+T on WIN SOURCE](#)
-  [Maxim Integrated Information](#)

## Optimize Your Supply Chain with WIN SOURCE Solutions

-  Global Sourcing Solution
-  Obsolete Management
-  Cost Control Management
-  Shortage Management
-  Alternative Solution
-  Excess Inventory Management