



**THE DATASHEET OF
MASWSS0107TR**



GaAs Broadband DPDT Diversity Switch 1.0 - 6.0 GHz

Rev. V1

Features

- 802.11a + b/g Broadband Applications
- Broadband Performance: 1.0 - 6.0 GHz
- Low Insertion Loss: 1.0 dB @ 2.4 GHz
1.2 dB @ 6.0 GHz
- High Isolation: 38 dB @ 2.4 GHz
31 dB @ 6.0 GHz
- Fast Switching Speed: 0.5 μ m GaAs PHEMT
- Lead-Free 3 mm 12-Lead PQFN Package
- 100% Matte Tin Plating over Copper
- Halogen-Free "Green" Mold Compound
- RoHS* Compliant and 260°C Reflow Compatible

Description

M/A-COM's MASWSS0107 is a broadband GaAs PHEMT MMIC diversity switch in a low cost, lead-free 3 mm 12-lead PQFN package. The MASWSS0107 is ideally suited for applications where very small size and low cost are required.

Typical applications are for WLAN IEEE 802.11a and 802.11b/g systems that employ two antennas for transmit and receive diversity. Other applications include cordless phones and base stations. Designed for high power, this DPDT switch maintains high linearity up to 6.0 GHz.

The MASWSS0107 can be controlled with either two or four control signals. With four control signals each of the four insertion paths can be controlled individually. To control the switch with only two signals, tie pairs of control lines together.

The MASWSS0107 is fabricated using a 0.5 micron gate length GaAs PHEMT process. The process features full passivation for performance and reliability.

Ordering Information ¹

Part Number	Package
MASWSS0107TR-3000	3000 piece reel
MASWSS0107SMB	Sample Test Board (Includes 5 Samples)

1. Reference Application Note M513 for reel size information.

* Restrictions on Hazardous Substances, European Union Directive 2002/95/EC.

Functional Schematic

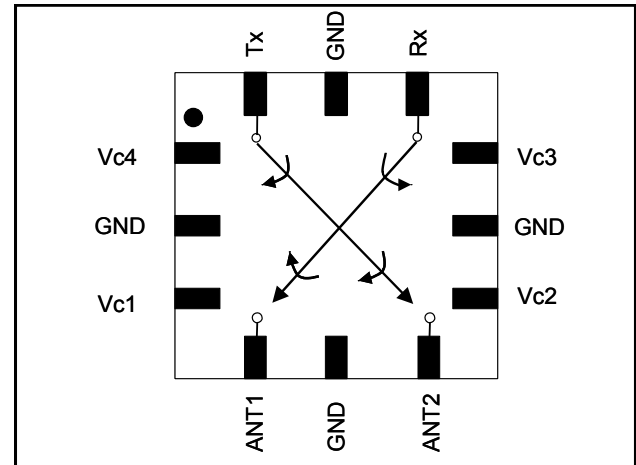

Pin Configuration

Pin No.	Pin Name	Description
1	Vc4	Control 4
2	GND	Ground
3	Vc1	Control 1
4	ANT1	Antenna Port 1
5	GND	Ground
6	ANT2	Antenna Port 2
7	Vc2	Control 2
8	GND	Ground
9	Vc3	Control 3
10	Rx	Receive Port
11	GND	Ground
12	Tx	Transmit Port
13	Paddle ²	DC and RF Ground

2. The exposed pad centered on the package bottom must be connected to RF and DC ground.

GaAs Broadband DPDT Diversity Switch 1.0 - 6.0 GHz

Rev. V1

Electrical Specifications: $T_A = 25^\circ\text{C}$, $Z_0 = 50 \Omega$, $V_C = 0 \text{ V} / 3 \text{ V}$, 5 pF Capacitor³

Parameter	Test Conditions	Units	Min.	Typ.	Max.
Insertion Loss ⁴	2.4 GHz	dB	—	1.0	1.3
	2 - 4 GHz	dB	—	1.1	—
	4 - 5 GHz	dB	—	1.2	—
	4.9 - 6 GHz	dB	—	1.2	—
Isolation (Input to Output)	One Path Active 2.4 GHz	dB	36	38	—
	4.9 - 6 GHz	dB	—	32	—
Isolation (Input to Output)	Both Paths Active 2.4 GHz	dB	—	33	—
	4.9 - 6 GHz	dB	—	27	—
Isolation (Antenna to Antenna) (Tx - Rx)	One Path Active 2.4 GHz	dB	—	31	—
	4.9 - 6 GHz	dB	—	22	—
	2.4 GHz	dB	—	30	—
	4.9 - 6 GHz	dB	—	27	—
Isolation (Antenna to Antenna) (Tx - Rx)	Both Paths Active 2.4 GHz	dB	—	25	—
	4.9 - 6 GHz	dB	—	20	—
	2.4 GHz	dB	—	25	—
	4.9 - 6 GHz	dB	—	27	—
Return Loss	2.4 GHz	dB	—	21	—
	4.9 - 6 GHz	dB	—	19	—
IP2	Two Tone, 15 dBm/tone, 5 MHz Spacing 2.4 GHz	dBm	—	91	—
	4.9 - 6 GHz	dBm	—	90	—
IP3	Two Tone, 15 dBm/tone, 5 MHz Spacing 2.4 GHz	dBm	—	53	—
	4.9 - 6 GHz	dBm	—	51	—
Input P0.1dB	2.4 GHz	dBm	—	27	—
	4.9 - 6 GHz	dBm	—	29	—
Input P1dB	2.4 GHz	dBm	—	33	—
	4.9 - 6 GHz	dBm	—	32	—
2 nd Harmonic	$P_{IN} = 20 \text{ dBm}$ 2.4 GHz	dBm	—	-77	—
	5.8 GHz	dBm	—	-75	—
3 rd Harmonic	$P_{IN} = 20 \text{ dBm}$ 2.4 GHz	dBm	—	-76	—
	5.8 GHz	dBm	—	-78	—
Trise, Tfall	10% to 90% RF	nS	—	80	—
	90% to 10% RF	nS	—	70	—
Ton, Toff	50% control to 90% RF, and 50% control to 10% RF	nS	—	97	—
Transients		mV	—	14	—
Control Current	$ V_C = 3 \text{ V}$	μA	—	1	10

3. For positive voltage control, external DC blocking capacitors are required on all RF ports.

4. Insertion loss can be optimized by varying the DC blocking capacitor value.

GaAs Broadband DPDT Diversity Switch 1.0 - 6.0 GHz

Rev. V1

Truth Table ⁵

Control Vc1	Control Vc2	Control Vc3	Control Vc4	ANT1 - Rx	ANT1 - Tx	ANT2 - Rx	ANT2 - Tx
1	0	0	0	Off	On	Off	Off
0	1	0	0	Off	Off	On	Off
0	0	1	0	On	Off	Off	Off
0	0	0	1	Off	Off	Off	On
0	0	1	1	On	Off	Off	On
1	1	0	0	Off	On	On	Off

5. 1 = +2.7 V to +5 V, 0 = 0 V \pm 0.2 V.

Absolute Maximum Ratings ^{6,7}

Parameter	Absolute Maximum
Input Power	+32 dBm
Operating Voltage	+8.5 volts
Operating Temperature	-40°C to +85°C
Storage Temperature	-65°C to +150°C

6. Exceeding any one or combination of these limits may cause permanent damage to this device.
7. M/A-COM does not recommend sustained operation near these survivability limits.

Handling Procedures

Please observe the following precautions to avoid damage:

Static Sensitivity

Gallium Arsenide Integrated Circuits are sensitive to electrostatic discharge (ESD) and can be damaged by static electricity. Proper ESD control techniques should be used when handling these devices.

GaAs Broadband DPDT Diversity Switch 1.0 - 6.0 GHz

Rev. V1

Typical Performance Curves, 5 pF Blocking Capacitors

Insertion Loss

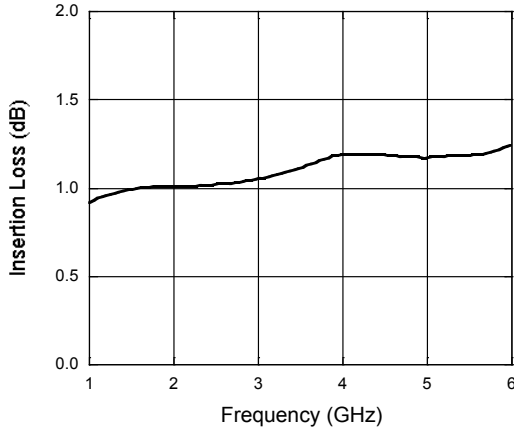

Return Loss

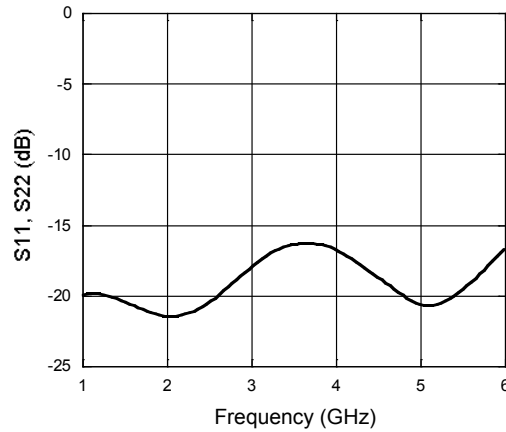

Isolation (Input to Output, One Path Active)

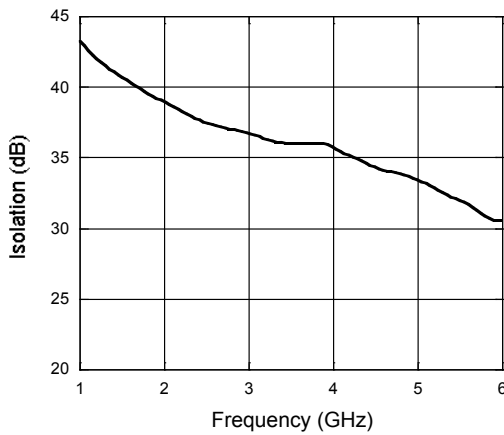

Isolation (Input to Output, Both Paths Active)

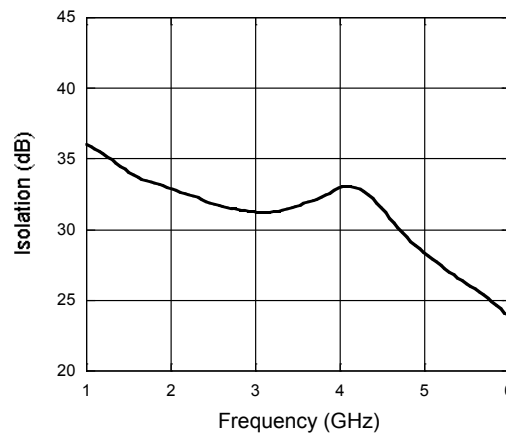

Lead-Free 3 mm 12-Lead PQFN†

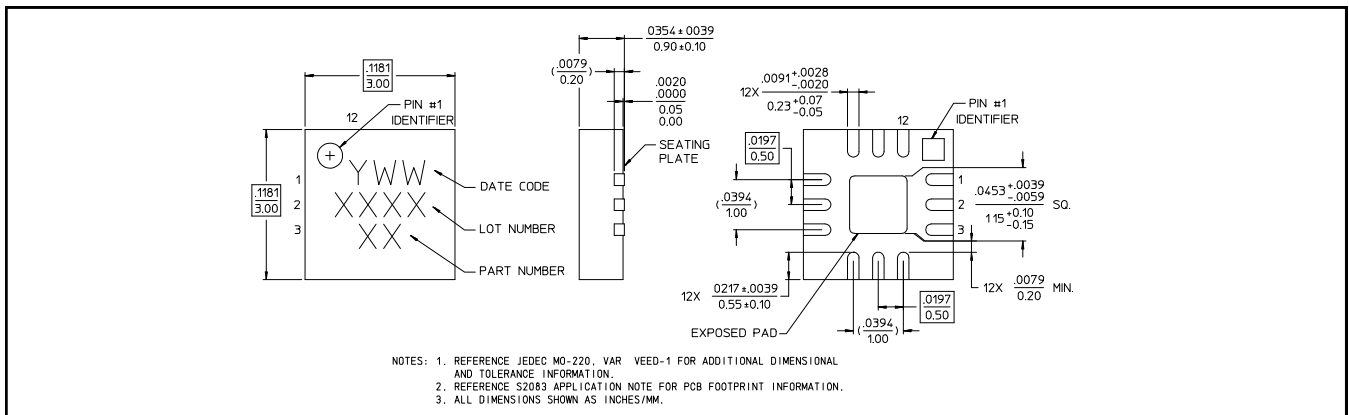

† Reference Application Note M538 for lead-free solder reflow recommendations.

M/A-COM Technology Solutions Inc. All rights reserved.

Information in this document is provided in connection with M/A-COM Technology Solutions Inc ("MACOM") products. These materials are provided by MACOM as a service to its customers and may be used for informational purposes only. Except as provided in MACOM's Terms and Conditions of Sale for such products or in any separate agreement related to this document, MACOM assumes no liability whatsoever. MACOM assumes no responsibility for errors or omissions in these materials. MACOM may make changes to specifications and product descriptions at any time, without notice. MACOM makes no commitment to update the information and shall have no responsibility whatsoever for conflicts or incompatibilities arising from future changes to its specifications and product descriptions. No license, express or implied, by estoppel or otherwise, to any intellectual property rights is granted by this document.

THESE MATERIALS ARE PROVIDED "AS IS" WITHOUT WARRANTY OF ANY KIND, EITHER EXPRESS OR IMPLIED, RELATING TO SALE AND/OR USE OF MACOM PRODUCTS INCLUDING LIABILITY OR WARRANTIES RELATING TO FITNESS FOR A PARTICULAR PURPOSE, CONSEQUENTIAL OR INCIDENTAL DAMAGES, MERCHANTABILITY, OR INFRINGEMENT OF ANY PATENT, COPYRIGHT OR OTHER INTELLECTUAL PROPERTY RIGHT. MACOM FURTHER DOES NOT WARRANT THE ACCURACY OR COMPLETENESS OF THE INFORMATION, TEXT, GRAPHICS OR OTHER ITEMS CONTAINED WITHIN THESE MATERIALS. MACOM SHALL NOT BE LIABLE FOR ANY SPECIAL, INDIRECT, INCIDENTAL, OR CONSEQUENTIAL DAMAGES, INCLUDING WITHOUT LIMITATION, LOST REVENUES OR LOST PROFITS, WHICH MAY RESULT FROM THE USE OF THESE MATERIALS.

MACOM products are not intended for use in medical, lifesaving or life sustaining applications. MACOM customers using or selling MACOM products for use in such applications do so at their own risk and agree to fully indemnify MACOM for any damages resulting from such improper use or sale.

Looking for pricing, stock, or lifecycle information?

Click below to explore more details on WIN SOURCE:

- ⊖ [View MASWSS0107TR](#) on WIN SOURCE
- ⊖ [M/A-Com Technology Solutions](#) Information

Optimize Your Supply Chain with WIN SOURCE Solutions

- ✓ Global Sourcing Solution
- ✓ Obsolete Management
- ✓ Cost Control Management
- ✓ Shortage Management
- ✓ Alternative Solution
- ✓ Excess Inventory Management