



**THE DATASHEET OF
MASW-007107-TR3000**



GaAs Broadband SPDT Switch

DC - 8 GHz



MASW-007107

Rev. V8

Features

- 802.11a + b/g and MIMO Applications
- Test and Measurement and Low/Medium Power Telecommunication Applications up to 8 GHz
- Broadband Performance: DC - 8 GHz
- Low Insertion Loss: 0.5 dB from 2 - 6 GHz
- High Isolation: 30 dB from 2 - 6 GHz
- Positive or Negative Control
- Fast Settling for Low Gate Lag Requirements
- Lead-Free 2 mm 8-Lead PDFN Package
- RoHS* Compliant

Applications

- Aerospace & Defense
- ISM

Description

The MASW-007107 is a broadband GaAs pHEMT MMIC SPDT switch in a lead-free 2 mm 8-lead PDFN package. Typical applications are for WLAN IEEE 802.11a + b/g, and MIMO. Other applications include test equipment requiring ultra fast switching speeds. Designed for low insertion loss, this SPDT switch maintains low loss up to 8 GHz.

The MASW-007107 is fabricated using a 0.5 micron gate length GaAs pHEMT process. This process features full passivation for performance and reliability.

Ordering Information^{1,2}

Part Number	Package
MASW-007107-TR3000	3000 piece reel
MASW-007107-000SMB	Sample Test Board
MASW-007107-000DIE ³	Separated die on grip ring
MASW-007107-0GPDIE	100 piece gel pack

1. Reference Application Note M513 for reel size information.
2. All sample boards include 5 loose parts.
3. Die quantity varies.

Functional Schematic

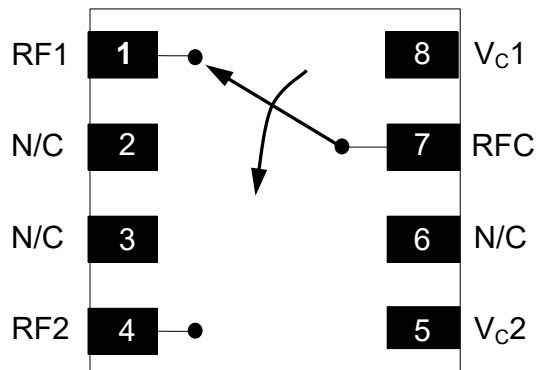

Pin Configuration⁴

Pin No.	Pin Name	Description
1	RF1	RF Output 1
2, 3, 6	N/C	No Connection
4	RF2	RF Output 2
5	V _c 2	Voltage Control 2
7	RFC	RF Common
8	V _c 1	Voltage Control 1
9	Paddle ⁵	RF and DC Ground

4. MACOM recommends connecting unused package pins to ground.
5. The exposed pad centered on the package bottom must be connected to RF, DC and thermal ground.

* Restrictions on Hazardous Substances, compliant to current RoHS EU directive.

GaAs Broadband SPDT Switch

DC - 8 GHz



MASW-007107

Rev. V8

Electrical Specifications: $T_A = +25^\circ\text{C}$, $V_C = 0\text{ V} / 3\text{ V}$, $Z_0 = 50\ \Omega$, 8 pF Capacitor^{6,7}

Parameter	Test Conditions	Units	Min.	Typ.	Max.
Insertion Loss ⁸	2.0 - 6.0 GHz	dB	—	0.50	0.8
	6.0 - 8.0 GHz			0.75	—
Isolation	2.4 GHz	dB	24	29	—
	5.3 GHz		28	33	
	5.8 GHz		25	30	
	6.0 - 8.0 GHz		—	20	
Return Loss	DC - 8.0 GHz	dB	—	16	—
Input IP2	Two Tone, 5 dBm / Tone, 5 MHz Spacing	dBm	—	92	—
	2.4 GHz			83	
	5.3 GHz			85	
	5.8 GHz			—	
Input IP3	Two Tone, 5 dBm / Tone, 10 MHz Spacing	dBm	—	54	—
	2.4 GHz (3 V)			49	
	5.8 GHz (3 V)			—	
	2.4 GHz (5 V)			55	
	5.8 GHz (5 V)			51	
	Two Tone, 15 dBm / Tone, 10 MHz Spacing			57	
2.4 GHz (3 V)	54				
5.8 GHz (3 V)	—				
2.4 GHz (5 V)	59				
5.8 GHz (5 V)	58				
Input P0.1dB	2.4 GHz	dBm	—	26	—
	5.3 GHz			26	
	5.8 GHz			25	
Input P1dB	2.4 GHz	dBm	—	30.5	—
	5.3 GHz			29.5	
	5.8 GHz			27.0	
Linear Pout	2.4 GHz, OFDM, QAM-64, 54 Mbps, EVM = 2.5%	dBm	—	21.0	—
	3 V			27.5	
	5 V			30.0	
	8 V	—	—		
2nd Harmonic	2.4 GHz, $P_{IN} = 20\text{ dBm}$	dBc	—	-80	—
	5.3 GHz, $P_{IN} = 20\text{ dBm}$			-71	
	5.8 GHz, $P_{IN} = 20\text{ dBm}$			-71	
3rd Harmonic	2.4 GHz, $P_{IN} = 20\text{ dBm}$	dBc	—	-83	—
	5.3 GHz, $P_{IN} = 20\text{ dBm}$			-71	
	5.8 GHz, $P_{IN} = 20\text{ dBm}$			-72	
T_{RISE}, T_{FALL}	10% to 90% RF and 90% to 10% RF	ns	—	13	—
T_{ON}, T_{OFF}	50% control to 90% RF and 50% control to 10% RF	ns	—	35	—
Transients	—	mV	—	14	—
Control Current	$ V_C = 3\text{ V}$	μA	—	1	5
RON	$t > 90\text{ ms}$ after OFF to ON Switching (settled)	Ω	—	2.50	—
Gate Lag	$ \Delta R_{on} $ between 15 μs and 90 ms after OFF to ON Switching	Ω	—	0.15	—

6. For positive voltage control, external DC blocking capacitors are required on all RF ports.

7. Electrical minimum and maximum specifications are guaranteed in final package assembly only.

8. Insertion loss can be optimized by varying the DC blocking capacitor value.

2

MACOM Technology Solutions Inc. (MACOM) and its affiliates reserve the right to make changes to the product(s) or information contained herein without notice. Visit www.macom.com for additional data sheets and product information.

For further information and support please visit:
<https://www.macom.com/support>

DC-0008121

Absolute Maximum Ratings^{9,10}

Parameter	Absolute Maximum
Input Power @ 3 V Control	32 dBm
Input Power @ 5 V Control	34 dBm
Operating Voltage	8.5 volts
Operating Temperature	-40°C to +85°C
Storage Temperature	-65°C to +150°C

9. Exceeding any one or combination of these limits may cause permanent damage to this device.
 10. MACOM does not recommend sustained operation near these survivability limits.

Truth Table^{11,12}

Control V _{c1}	Control V _{c2}	RFC - RF1	RFC - RF2
1	0	On	Off
0	1	Off	On

11. Positive Control: 1 = +2.9 V to +8.0 V, 0 = 0 V ± 0.2 V.
 Negative Control: 1 = 0 V ± 0.2 V, 0 = -2.9 V to -8.0 V
 12. If using negative control, external DC blocking capacitors can be omitted on RF ports, provided that the DC level of the external circuit on the RF port is 0 VDC.

Application Schematic

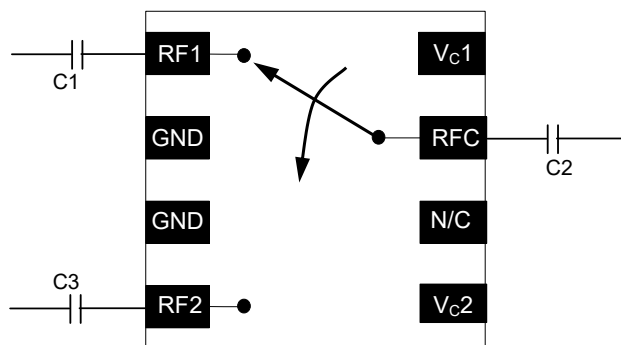

C1, C2, C3 = 8 pF

Qualification

Qualified to MACOM specification REL-201, Process Flow -2.

Handling Procedures

Please observe the following precautions to avoid damage:

Static Sensitivity

These electronic devices are sensitive to electrostatic discharge (ESD) and can be damaged by static electricity. Proper ESD control techniques should be used when handling these devices.

Typical Performance Curves

Return Loss vs. Frequency

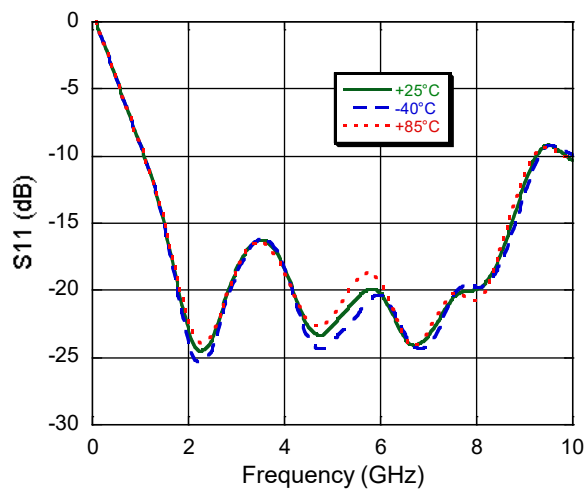

Isolation vs. Frequency

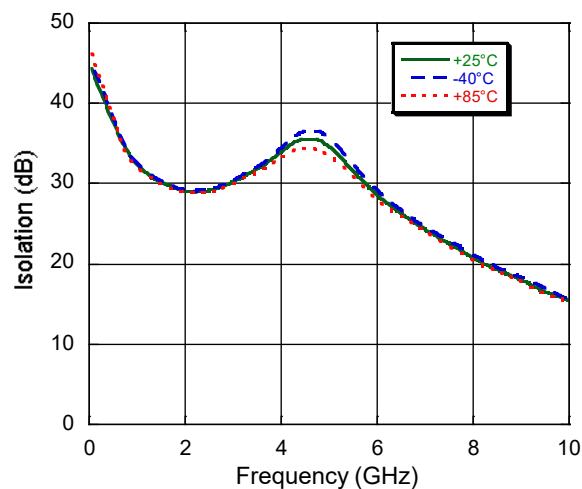

Insertion Loss vs. Frequency

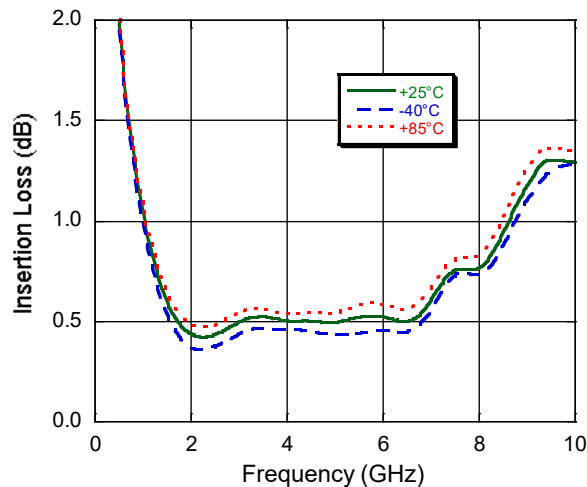

EVM vs. Pout @ 2.4 GHz

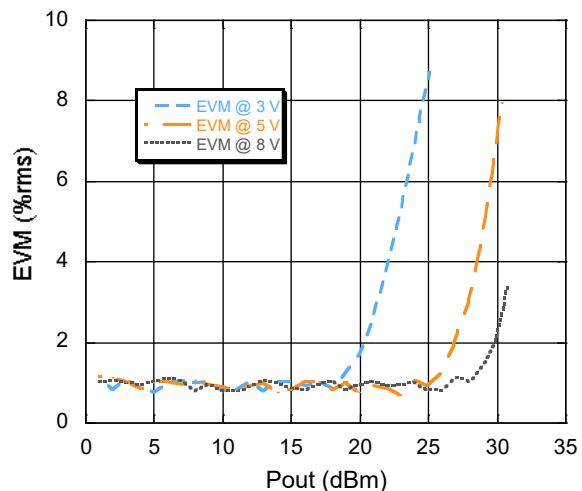

Die Outline Drawing^{13,14,15,16}

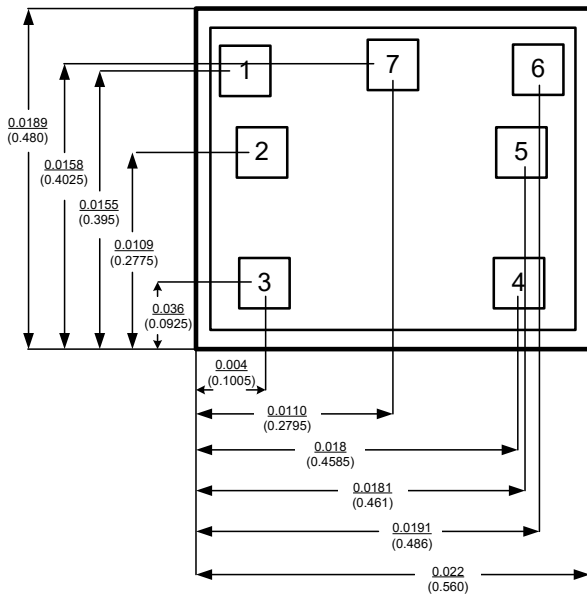

Die Size - Inches (mm)

0.022 x 0.0189 x 0.008 (0.56 x 0.48 x 0.203)

- 13. Typical dimensions in inches (millimeters).
- 14. Die thickness is 0.008" (0.203 mm).
- 15. Typical bond pad is 0.003" square (0.076 mm square).
- 16. Bond pad metallization is gold.

Die Bond Pad Configuration

Pad #	Name	Description
1	V _{c1}	Voltage Control 1
2	RF1	RF Output 1
3, 4	GND	Ground
5	RF2	RF Output 2
6	V _{c2}	Voltage Control 2
7	RFC	RF Common

Lead Free 2 mm 8-lead PDFN †

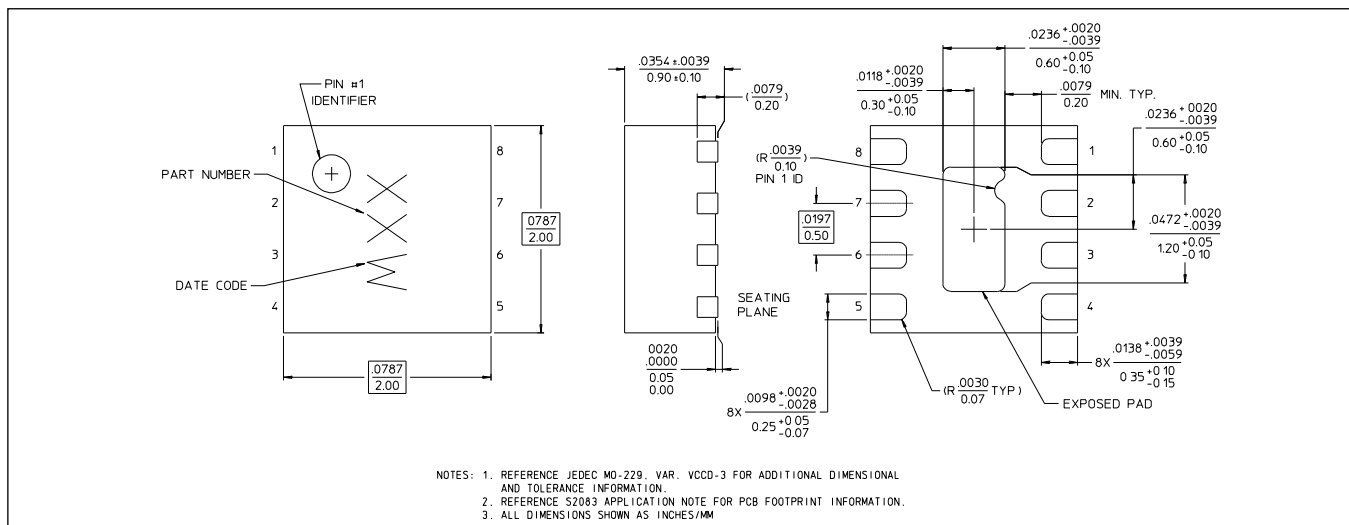

† Reference Application Note S2083 for lead-free solder reflow recommendations.
Meets JEDEC moisture sensitivity level 1 requirements.

MACOM Technology Solutions Inc. ("MACOM"). All rights reserved.

These materials are provided in connection with MACOM's products as a service to its customers and may be used for informational purposes only. Except as provided in its Terms and Conditions of Sale or any separate agreement, MACOM assumes no liability or responsibility whatsoever, including for (i) errors or omissions in these materials; (ii) failure to update these materials; or (iii) conflicts or incompatibilities arising from future changes to specifications and product descriptions, which MACOM may make at any time, without notice. These materials grant no license, express or implied, to any intellectual property rights.

THESE MATERIALS ARE PROVIDED "AS IS" WITH NO WARRANTY OR LIABILITY, EXPRESS OR IMPLIED, RELATING TO SALE AND/OR USE OF MACOM PRODUCTS INCLUDING FITNESS FOR A PARTICULAR PURPOSE, MERCHANTABILITY, INFRINGEMENT OF INTELLECTUAL PROPERTY RIGHT, ACCURACY OR COMPLETENESS, OR SPECIAL, INDIRECT, INCIDENTAL, OR CONSEQUENTIAL DAMAGES WHICH MAY RESULT FROM USE OF THESE MATERIALS.

MACOM products are not intended for use in medical, lifesaving or life sustaining applications. MACOM customers using or selling MACOM products for use in such applications do so at their own risk and agree to fully indemnify MACOM for any damages resulting from such improper use or sale.

Looking for pricing, stock, or lifecycle information?

Click below to explore more details on WIN SOURCE:

- ⊖ [View MASW-007107-TR3000 on WIN SOURCE](#)
- ⊖ [M/A-Com Technology Solutions Information](#)

Optimize Your Supply Chain with WIN SOURCE Solutions

- ✓ Global Sourcing Solution
- ✓ Obsolete Management
- ✓ Cost Control Management
- ✓ Shortage Management
- ✓ Alternative Solution
- ✓ Excess Inventory Management