

Features

- +12 dBm Input Power @ 1 dB Compression
- High Isolation, 28 dB LO to RF
- +3 to +8 dBm LO Drive Level
- DC - 500 MHz 3 dB IF Bandwidth
- Does not require DC bias
- Lead-Free SOT-25 Package
- 100% Matte Tin Plating over Copper
- Halogen-Free “Green” Mold Compound
- 260°C Reflow Compatible
- RoHS* Compliant Version of MD54-0006

Description

M/A-COM's MAMXSS0013 is a passive mixer that achieves the performance of a double balanced diode mixer in a lead-free SOT-25 package. The MAMXSS0013 is ideally suited for use where high level RF signals and very wide dynamic range are required. Typical applications include frequency up/down conversion, modulation and demodulation in receivers and transmitters for base station and portable systems.

The MAMXSS0013 uses FETs as mixing elements to achieve very wide dynamic range in a low cost plastic package. The mixer operates with LO drive levels of +3 dBm to +8 dBm. The LO port may be externally tuned for operation in various frequency bands.

M/A-COM's MAMXSS0013 is fabricated using a mature 0.5 micron gate length GaAs MESFET process. The process features full passivation for increased performance and reliability. The MAMXSS0013 is 100% RF tested to ensure performance specification compliance.

Ordering Information¹

Part Number	Package
MAMXSS0013	Bulk Packaging
MAMXSS0013TR-3000	3000 piece reel
MAMX-000013-001SMB	Sample Board 1500 MHz
MAMX-000013-002SMB	Sample Board 1710 MHz
MAMX-000013-003SMB	Sample Board 2300 MHz

1. Reference Application Note M513 for reel size information.

* Restrictions on Hazardous Substances, European Union Directive 2002/95/EC.

Functional Block Diagram

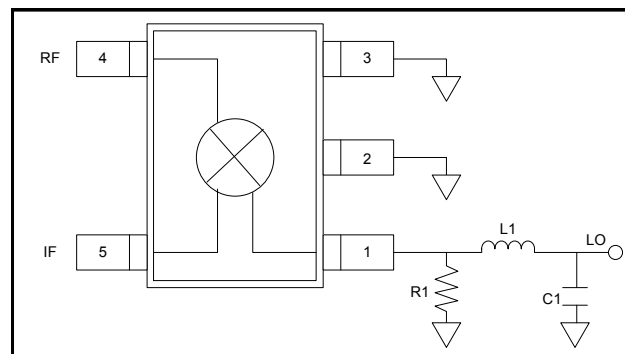

Pin Configuration

Pin No.	Pin Name	Description
1	LO Port	LO Input
2	Ground	Ground
3	Ground	Ground
4	RF Port	RF Input
5	IF Port	IF Output

External Circuitry Parts List^{2,3}

Part	LO Frequency		
	1500 MHz	1710 MHz	2300 MHz
R1	470 Ω	470 Ω	820 Ω
L1	6.8 nH	4.7 nH	2.7 nH
C1	3.3 pF	2.2 pF	2.2 pF

- The external LO matching network allows tuning from 1400 MHz to 2300 MHz. The networks given above are intended to serve as guidelines for matching in different bands.
- All off-chip components are low-cost surface mount components obtainable from multiple sources (0.060 in. x 0.030 in. or 0.080 in. x 0.050 in.).

Low Cost MMIC Mixer 1400 - 2100 MHz

Rev. V3

Electrical Specifications⁴:

RF = 1850 MHz (-10 dBm), LO = 1710 MHz (+5 dBm), IF = 140 MHz, T_A = 25°C

Parameter	Test Conditions	Units	Min.	Typ.	Max.
Conversion Loss		dB	—	8.0	9.0
Isolation	LO to RF	dB	—	28	—
	LO to IF	dB	—	15	—
	RF to IF	dB	—	15	—
VSWR	RF Port	Ratio	—	2.0:1	—
	LO Port ³	Ratio	—	2.0:1	—
	IF Port	Ratio	—	2.0:1	—
Input 1 dB Compression	LO = +5 dBm, RF Freq: 1850 MHz	dBm	—	12	—
Two-Tone IM Ratio ⁵	Two Tones at -10 dBm each, Tone spacing = 100 KHz, IF = 140 MHz	dBc	—	55	—

4. With external LO Port matching. See functional block diagram.

5. IMR vs. RF drive can be calculated by the formula: IMR = 40-1.5*Pin.

Absolute Maximum Ratings^{6,7}

Parameter	Absolute Maximum
RF Input Power	+27 dBm
LO Drive Power	+27 dBm
Operating Temperature	-40°C to +85°C
Storage Temperature	-65°C to +150°C

6. Exceeding any one or combination of these limits may cause permanent damage to this device.

7. M/A-COM does not recommend sustained operation near these survivability limits.

Spurious Table

Harmonic of LO	4x	38.3 27.3	41.3 39.9	45.4 52.5	64.7 77.1	57.0 78.7
	3x	21.4 10.5	30.1 30.1	69.0 70.5	43.0 58.8	68.3 76.8
	2x	9.0 -0.9	36.1 36.4	36.0 45.8	65.8 75.0	64.3 78.0
	1x	1.9 -6.0	0 0	44.8 55.5	56.1 75.2	65.0 78.3
	0x	X X	8.1 8.3	45.5 54.4	56.8 72.3	72.9 74.3
		0x	1x	2x	3x	4x
Harmonic of RF						

The spurious table shows the spurious signals resulting from the mixing of the RF and LO input signals, assuming down conversion. Mixing products are indicated relative to the IF. The lower frequency mixing term is shown for two different RF input levels. The top number is for an RF input power of 0 dBm, the lower number is for -10 dBm.

$|nF_{RF} - mF_{LO}|$, RF = 0 dBm
 $|nF_{RF} - mF_{LO}|$, RF = -10 dBm
 RF Frequency = 1850 MHz
 LO Frequency = 1710 MHz

Recommended PCB Configuration

Layout View

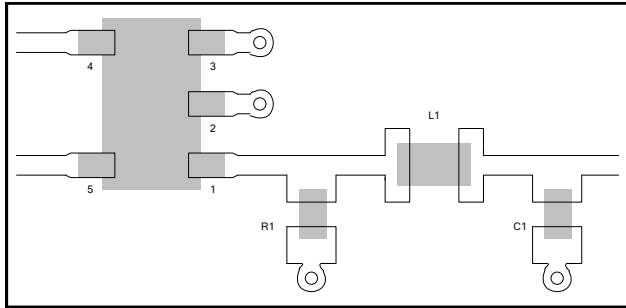

Cross Section View

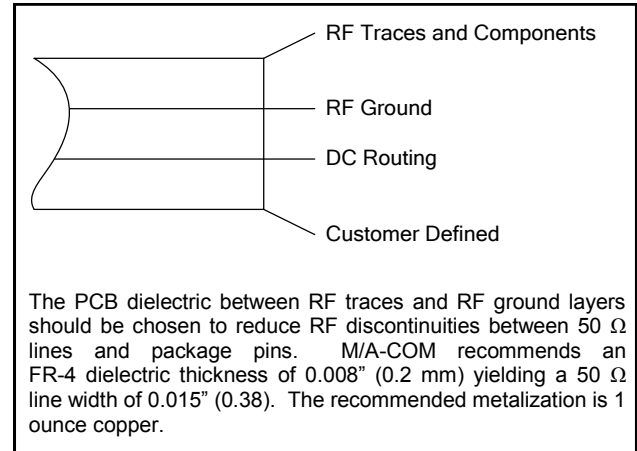

Lead-Free SOT-25[†]

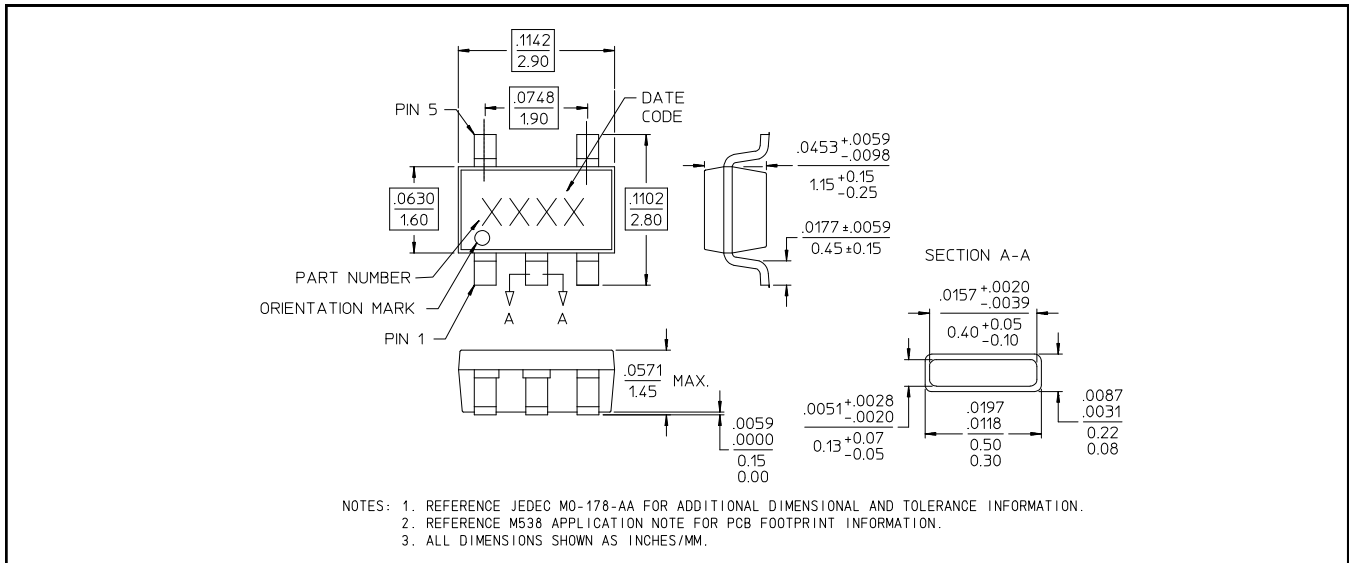

[†] Reference Application Note M538 for lead-free solder reflow recommendations.
Meets JEDEC moisture sensitivity level 1 requirements.

Low Cost MMIC Mixer 1400 - 2100 MHz

Rev. V3

Typical Performance Curves

- **Test Conditions for Down Converter Application:** RF = 1850 MHz (-10 dBm), IF = 140 MHz, LO = 1710 MHz (+5 dBm).
- **Test Conditions for Up Converter Application:** LO = 1710 MHz (+5 dBm), IF = 140 MHz (-10 dBm), RF = 1850 MHz.

Conversion Loss (Up/Down)

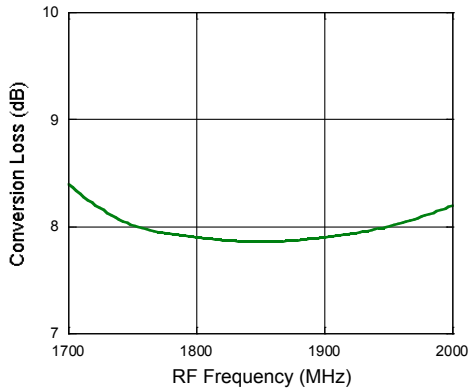

VSWR

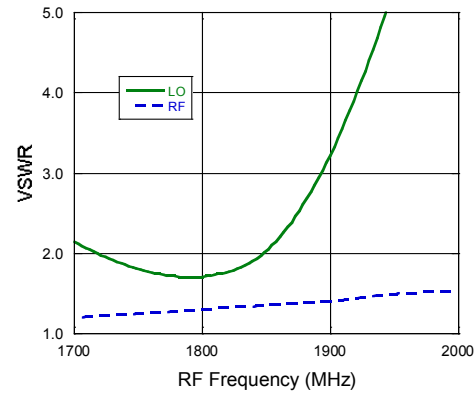

Two-Tone IMR

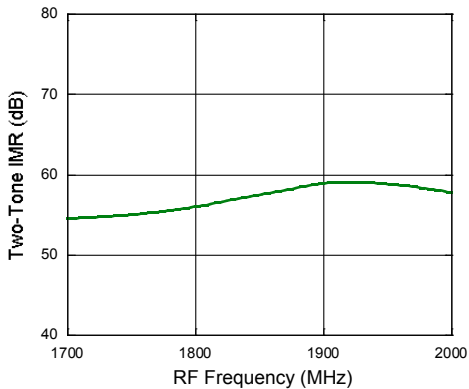

Isolation

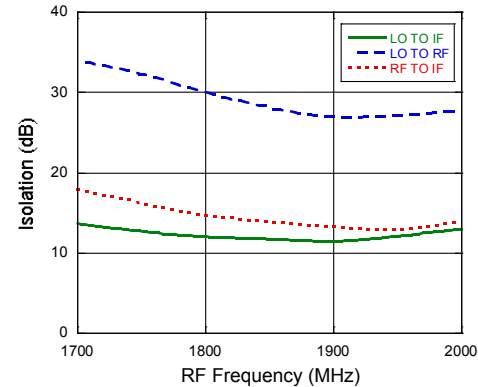

Wide-

- **Test Conditions for Wide-Band Application:** RF = -10 dBm, IF = 140 MHz, LO = +11 dBm, LO Port resistively matched. Lower LO drive operation is available for narrow band performance using external reactive matching. The 3 dB IF bandwidth is 500 MHz. IF frequencies above 200 MHz can be optimized for low conversion loss by using external matching components.

Conversion Loss

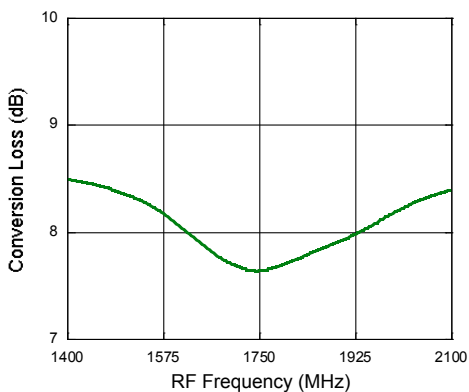

Two-Tone IMR

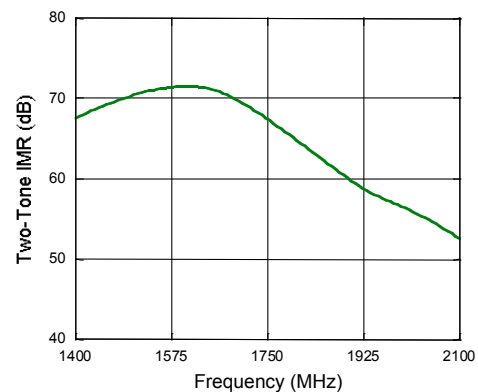

M/A-COM Technology Solutions Inc. All rights reserved.

Information in this document is provided in connection with M/A-COM Technology Solutions Inc ("MACOM") products. These materials are provided by MACOM as a service to its customers and may be used for informational purposes only. Except as provided in MACOM's Terms and Conditions of Sale for such products or in any separate agreement related to this document, MACOM assumes no liability whatsoever. MACOM assumes no responsibility for errors or omissions in these materials. MACOM may make changes to specifications and product descriptions at any time, without notice. MACOM makes no commitment to update the information and shall have no responsibility whatsoever for conflicts or incompatibilities arising from future changes to its specifications and product descriptions. No license, express or implied, by estoppel or otherwise, to any intellectual property rights is granted by this document.

THESE MATERIALS ARE PROVIDED "AS IS" WITHOUT WARRANTY OF ANY KIND, EITHER EXPRESS OR IMPLIED, RELATING TO SALE AND/OR USE OF MACOM PRODUCTS INCLUDING LIABILITY OR WARRANTIES RELATING TO FITNESS FOR A PARTICULAR PURPOSE, CONSEQUENTIAL OR INCIDENTAL DAMAGES, MERCHANTABILITY, OR INFRINGEMENT OF ANY PATENT, COPYRIGHT OR OTHER INTELLECTUAL PROPERTY RIGHT. MACOM FURTHER DOES NOT WARRANT THE ACCURACY OR COMPLETENESS OF THE INFORMATION, TEXT, GRAPHICS OR OTHER ITEMS CONTAINED WITHIN THESE MATERIALS. MACOM SHALL NOT BE LIABLE FOR ANY SPECIAL, INDIRECT, INCIDENTAL, OR CONSEQUENTIAL DAMAGES, INCLUDING WITHOUT LIMITATION, LOST REVENUES OR LOST PROFITS, WHICH MAY RESULT FROM THE USE OF THESE MATERIALS.

MACOM products are not intended for use in medical, lifesaving or life sustaining applications. MACOM customers using or selling MACOM products for use in such applications do so at their own risk and agree to fully indemnify MACOM for any damages resulting from such improper use or sale.

5

M/A-COM Technology Solutions Inc. (MACOM) and its affiliates reserve the right to make changes to the product(s) or information contained herein without notice.
Visit www.macom.com for additional data sheets and product information.

Looking for pricing, stock, or lifecycle information?

Click below to explore more details on WIN SOURCE:

- ⊖ [View MAMXSS0013TR-3000 on WIN SOURCE](#)
- ⊖ [M/A-Com Technology Solutions Information](#)

Optimize Your Supply Chain with WIN SOURCE Solutions

- ✓ Global Sourcing Solution
- ✓ Obsolete Management
- ✓ Cost Control Management
- ✓ Shortage Management
- ✓ Alternative Solution
- ✓ Excess Inventory Management