

Features

- Surface Mount Device
- No Wire Bonding Required
- Rugged Silicon-Glass Construction
- Silicon Nitride Passivation
- Polymer Scratch Protection
- Low Parasitic Capacitance and Inductance
- Higher Average and Peak Power Handling
- RoHS* Compliant and 260°C Reflow Compatible

Description and Applications

This device is a silicon-glass PIN diode chip fabricated with M/A-COM Technology Solutions patented HMIC™ process. This device features two silicon pedestals embedded in a low loss glass. The diode is formed on the top of one pedestal and connections to the backside of the device are facilitated by making the pedestal sidewalls conductive. Selective backside metalization is applied producing a surface mount device. The topside is fully encapsulated with silicon nitride and has an additional polymer layer for scratch protection. These protective coatings prevent damage to the junction and the anode air-bridge during handling and assembly.

These packageless devices are suitable for usage in moderate incident power (10 W C.W.) or higher incident peak power (500 W) series, shunt, or series-shunt switches. Small parasitic inductance, 0.35 nH, and an excellent RC time constant, 0.22 pS, make these devices ideal for switch applications where higher P_{1dB} and IP3 values are required. These diodes can also be used in p, T, tapered resistance, and switched-pad attenuator control circuits for 50W or 75W systems.

Ordering Information	
Gel Pack (100 pieces)	Tape and Reel Pocket Tape (3000 pieces)
MA4SPS502	MADP-000502-12700P

Case Style Outline Drawing ODS-1270^{1,2}

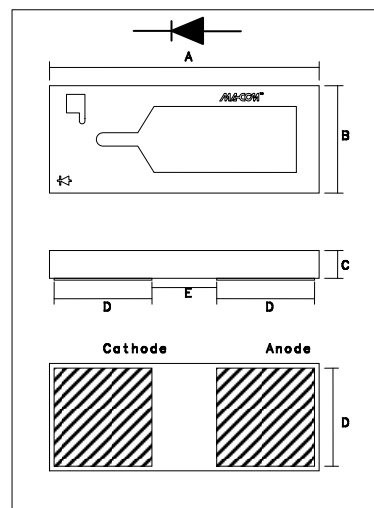

1. Backside metal: 0.1 μm thick.
2. Hatched areas indicate backside ohmic gold contacts.

DIM	INCHES		MM	
	Min.	Max.	Min.	Max.
A	0.058	0.062	1.47	1.57
B	0.026	0.030	0.66	0.76
C	0.004	0.006	0.10	0.15
D	0.020	0.022	0.51	0.56
E	0.013	0.015	0.33	0.38

Absolute Maximum Ratings @ $T_{AMB} = 25^{\circ}\text{C}$

Parameter	Absolute Maximum
Forward Current	600mA
Reverse Voltage	-275 V
Operating Temperature	-65°C to +125°C
Storage Temperature	-55 °C to +150°C
Junction Temperature	+175°C
Dissipated Power (RF & DC)	3W

* Restrictions on Hazardous Substances, European Union Directive 2002/95/EC.

Electrical Specifications @ T_{AMB} = +25°C

Symbol	Conditions	Units	Min.	Typical	Max.
C _T	-40V, 1MHz	pF		0.140	0.200
	-40V, 1GHz	pF		0.090	
R _S	100mA, 100MHz	Ω		1.4	2.2
	20mA, 100MHz	Ω		2.4	3.2
V _F	10mA	V		0.87	1.00
V _R	10μA	V	-200	-275	
I _R	-200V	μA			-10
	-40V	nA		8	
θ _{JL}	Steady State	°C/W		50	
T _L	+10mA / -6mA (50% - 90% V)	μS		2.8	

Handling

All semiconductor chips should be handled with care to avoid damage or contamination from perspiration and skin oils. The use of plastic tipped tweezers or vacuum pickups is strongly recommended for individual components. Bulk handling should ensure that abrasion and mechanical shock are minimized.

Die Attach

Attachment to a circuit board is made simple through the use of surface mount technology. Mounting pads are conveniently located on the bottom surface of these devices and are removed from the active junction locations. These devices are well suited for solder attachment onto hard and soft substrates. The use of 80/20, Au/Sn or RoHS compliant solders is recommended. A conductive silver epoxy may also be used.

When soldering these devices to a hard substrate, hot gas die bonding is preferred. We recommend utilizing a vacuum tip and force of 60 to 100 grams applied to the top surface of the device. When soldering to soft substrates, it is recommended to use a Gold-Tin interface at the circuit board mounting pads. Position the device so that its mounting pads are force aligned with the circuit board mounting pads and reflow the solder by heating the circuit trace near the mounting pads while applying 60 to 100 grams of perpendicular to the top surface of the die.

The solder joint must **not** be made one pad at a time. Doing so could create unequal heat flow and produce thermal and/or mechanical stresses. It is also **not** recommended to reflow solder by causing heat to flow through the top surface of the die. Since the HMIC glass is transparent, the edges of the mounting pads can be visually inspected through the die after attach is completed.

Typical Total Resistance (R_s) vs. Forward Current (I_f) and Frequency

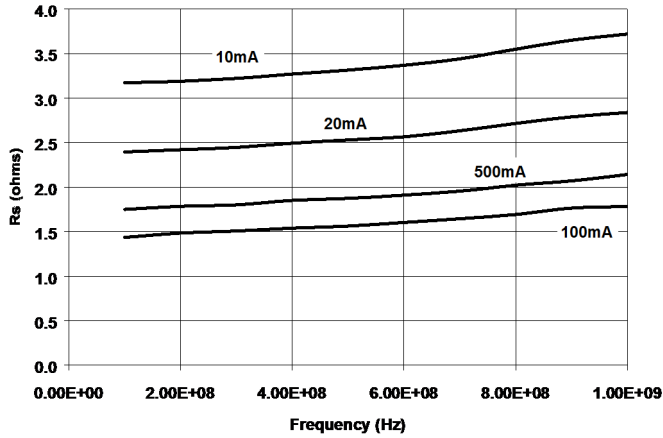

Typical Total Capacitance (C_T) vs. Reverse (V_r) Voltage and Frequency

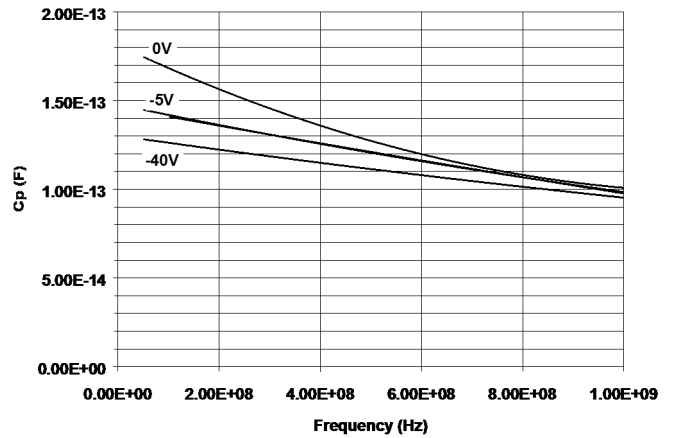

C_T vs. V_r @ 100MHz and 1GHz

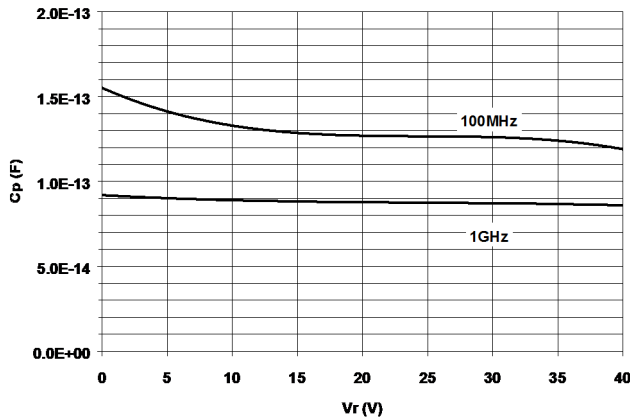

Parallel Resistance (R_p) vs. V_r @ 100MHz

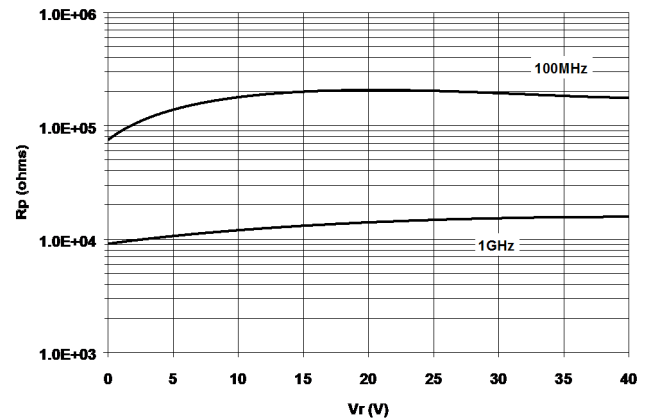

R_s vs. I_f @ 100MHz and 1GHz

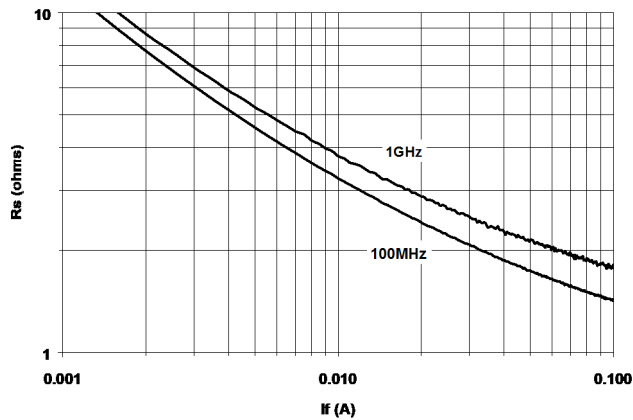

Series Inductance (L_s) vs. Frequency @ 10mA

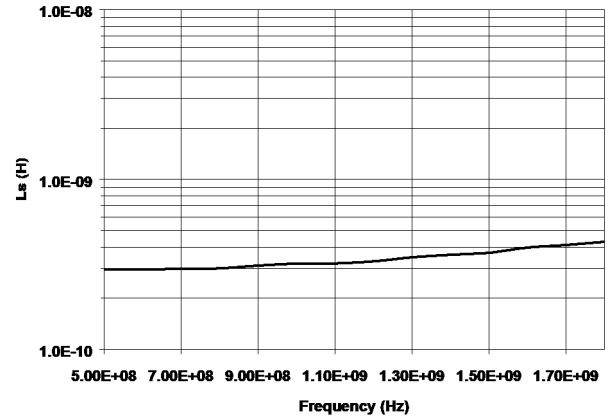

MA4SPS502 ADS SPICE Model & Schematic

MA4SPS502 SPICE Model

PinDiodeModel	wBv=200 V
NLPINM1	wPmax=2.0 W
Is=1.0E-14 A	Ffe=1.0
Vi=0.0 V	
Un=900 cm ² /V-sec	
Wi=40 um	
Rr=20 K Ohm	
Cmin=0.12 pF	
Tau=2.8 usec	
Rs=0.1 Ohm	
Cj0=0.18 pF	
Vj=0.7 V	
M=0.5	
Fc=0.5	
Imax=2.5E+7 A/m ²	
Kf=0.0	
Af=1.0	

MA4SPS502 Lumped Element Model

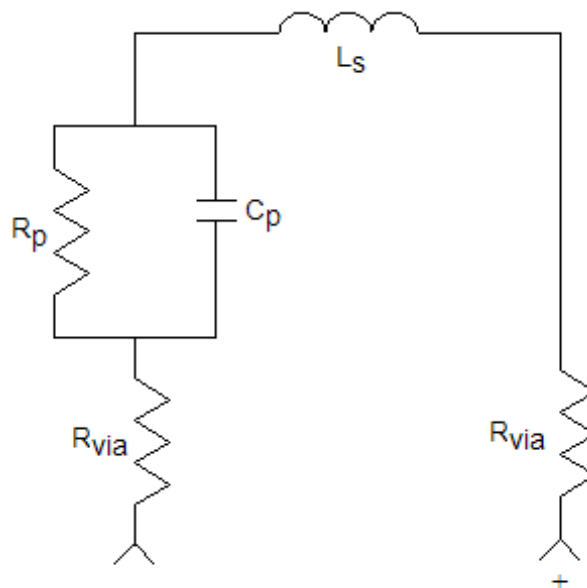

Note: $R_S = 2 \cdot R_{via} + R_p$

M/A-COM Technology Solutions Inc. All rights reserved.

Information in this document is provided in connection with M/A-COM Technology Solutions Inc ("MACOM") products. These materials are provided by MACOM as a service to its customers and may be used for informational purposes only. Except as provided in MACOM's Terms and Conditions of Sale for such products or in any separate agreement related to this document, MACOM assumes no liability whatsoever. MACOM assumes no responsibility for errors or omissions in these materials. MACOM may make changes to specifications and product descriptions at any time, without notice. MACOM makes no commitment to update the information and shall have no responsibility whatsoever for conflicts or incompatibilities arising from future changes to its specifications and product descriptions. No license, express or implied, by estoppels or otherwise, to any intellectual property rights is granted by this document.

THESE MATERIALS ARE PROVIDED "AS IS" WITHOUT WARRANTY OF ANY KIND, EITHER EXPRESS OR IMPLIED, RELATING TO SALE AND/OR USE OF MACOM PRODUCTS INCLUDING LIABILITY OR WARRANTIES RELATING TO FITNESS FOR A PARTICULAR PURPOSE, CONSEQUENTIAL OR INCIDENTAL DAMAGES, MERCHANTABILITY, OR INFRINGEMENT OF ANY PATENT, COPYRIGHT OR OTHER INTELLECTUAL PROPERTY RIGHT. MACOM FURTHER DOES NOT WARRANT THE ACCURACY OR COMPLETENESS OF THE INFORMATION, TEXT, GRAPHICS OR OTHER ITEMS CONTAINED WITHIN THESE MATERIALS. MACOM SHALL NOT BE LIABLE FOR ANY SPECIAL, INDIRECT, INCIDENTAL, OR CONSEQUENTIAL DAMAGES, INCLUDING WITHOUT LIMITATION, LOST REVENUES OR LOST PROFITS, WHICH MAY RESULT FROM THE USE OF THESE MATERIALS.

MACOM products are not intended for use in medical, lifesaving or life sustaining applications. MACOM customers using or selling MACOM products for use in such applications do so at their own risk and agree to fully indemnify MACOM for any damages resulting from such improper use or sale.

Looking for pricing, stock, or lifecycle information?

Click below to explore more details on WIN SOURCE:

- ⊖ [View MADP-000502-12700P on WIN SOURCE](#)
- ⊖ [M/A-Com Technology Solutions Information](#)

Optimize Your Supply Chain with WIN SOURCE Solutions

- ✓ Global Sourcing Solution
- ✓ Obsolete Management
- ✓ Cost Control Management
- ✓ Shortage Management
- ✓ Alternative Solution
- ✓ Excess Inventory Management