



**THE DATASHEET OF  
MAAVSS0001TR-3000**



## 2.25 V Voltage Variable Absorptive Attenuator, 42 dB 1.8 - 2.5 GHz

Rev. V3

### Features

- Single Positive Voltage Control, 0 to +2.25 Volts
- 42 dB Typical Attenuation Range at 2.4 GHz
- Low DC Power Consumption
- Lead-Free SOT-25 Package
- 100% Matte Tin Plating over Copper
- Halogen-Free “Green” Mold Compound
- 260°C Reflow Compatible
- RoHS\* Compliant Version of AT-119

### Description

M/A-COM's MAAVSS0001 is a GaAs MMIC voltage variable absorptive attenuator in a lead-free SOT-25 surface mount plastic package. M/A-COM fabricates the MAAVSS0001 with a proven monolithic GaAs 0.5 micron gate process that features full chip passivation for performance and reliability.

### Applications

The MAAVSS0001 is ideally suited for applications that require fine tuning, linear attenuation with voltage, and very low power consumption.

Typical applications for the MAAVSS0001 include automatic gain control circuits in satellite radio receivers and other wireless receivers.

### Ordering Information<sup>1</sup>

Part Number	Package
MAAVSS0001	Bulk Packaging
MAAVSS0001TR-3000	3000 piece reel
MAAVSS0001SMB	Sample Test Board (Includes 5 Samples)

1. Reference Application Note M513 for reel size information.

### Functional Schematic

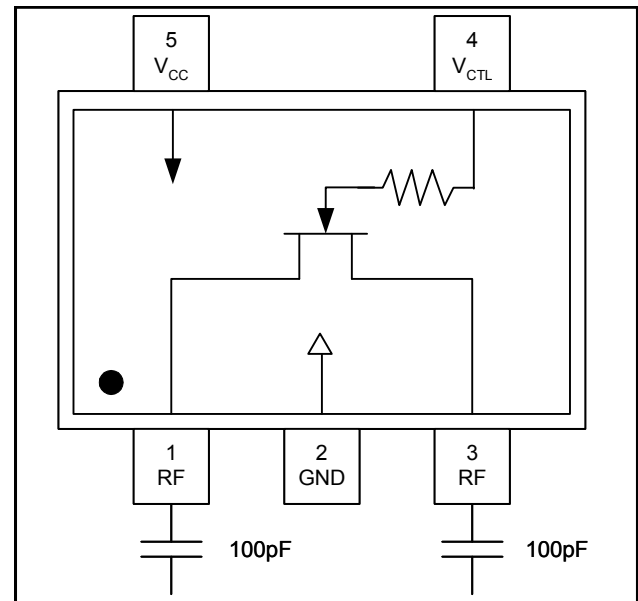

### Pin Configuration

Pin	Function	Description
1	RF	RF (input / output)
2	GND	Ground
3	RF	RF (input / output)
4	V <sub>CTL</sub>	Control Voltage
5	V <sub>CC</sub>	DC Supply Voltage

### Absolute Maximum Ratings<sup>2,3</sup> @ T<sub>A</sub> = +25°C (unless otherwise specified)

Parameter	Absolute Maximum
Input Power	+21 dBm
Supply Voltage V <sub>CC</sub>	-1 V ≤ V <sub>CC</sub> ≤ +8 V
Control Voltage V <sub>CTL</sub>	-1 V ≤ V <sub>CTL</sub> ≤ V <sub>CC</sub> + 0.5 V
Operating Temperature	-40°C to +85°C
Storage Temperature	-65°C to +150°C

2. Exceeding any one or combination of these limits may cause permanent damage to this device.

3. M/A-COM does not recommend sustained operation near these survivability limits.

\* Restrictions on Hazardous Substances, European Union Directive 2002/95/EC.

## 2.25 V Voltage Variable Absorptive Attenuator, 42 dB 1.8 - 2.5 GHz

Rev. V3

**Electrical Specifications:  $T_A = 25^\circ\text{C}$ , Frequency = 2.4 GHz,  $V_{CC} = 3.3\text{ V}$ ,  $Z_0 = 50\ \Omega$**

Parameter	Test Conditions <sup>4,5</sup>	Units	Min.	Typ.	Max.
Insertion Loss	$V_{CTL} = 2.25\text{ V}$	dB	—	2.4	3.2
Maximum Attenuation	$V_{CTL} = 0.5\text{ V}$	dB	37	42	—
Attenuation Slope	$0.75\text{ V} < V_{CTL} < 1.75\text{ V}$	dB/V	24	—	—
Return Loss	$0.0\text{ V} < V_{CTL} < 0.75\text{ V}$	dB	—	6	—
	$0.75\text{ V} < V_{CTL} < 1.75\text{ V}$	dB	—	10	—
	$1.75\text{ V} < V_{CTL} < 2.25\text{ V}$	dB	—	14	—
Input Power for 1dB Change in Attenuation	$0.75\text{ V} < V_{CTL} < 2.25\text{ V}$	dBm	—	10	—
Input 3rd Order Intercept Point	$0.75\text{ V} < V_{CTL} < 2.25\text{ V}$	dBm	—	15	—
Switching Speed	50% $V_{CTL}$ to 10% / 90% RF	nS	—	100	—
Transients	$V_{CTL} = 3\text{ V}$ , In-Band	mV	—	10	—

4. External DC blocking capacitors are required on all RF ports.

5.  $V_{CC} = +3.3\text{ V}$  @ 50  $\mu\text{A}$  typical.  $V_{CTL} = 0\text{ V}$  to  $+2.25\text{ V}$  @ 50  $\mu\text{A}$  typical.

### Application Schematic

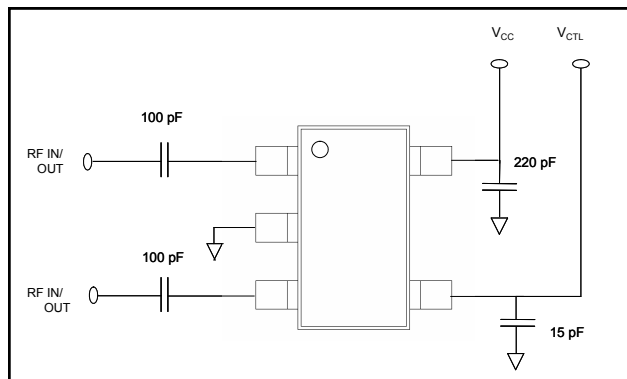

### Handling Procedures

Please observe the following precautions to avoid damage:

### Static Sensitivity

Gallium Arsenide Integrated Circuits are sensitive to electrostatic discharge (ESD) and can be damaged by static electricity. Proper ESD control techniques should be used when handling these devices.

## 2.25 V Voltage Variable Absorptive Attenuator, 42 dB 1.8 - 2.5 GHz

Rev. V3

### Typical Performance Curves

**Insertion Loss vs. Frequency**  
@ 2.25 V Control Voltage

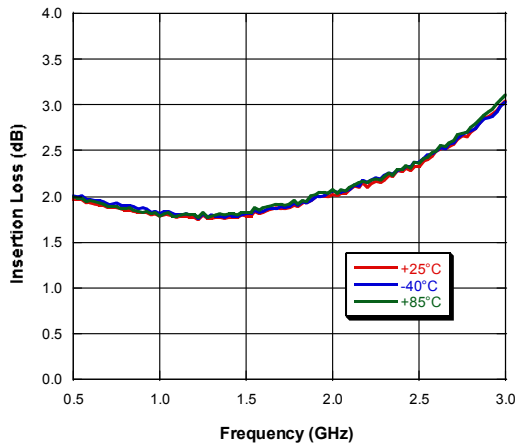

**Attenuation vs. Control Voltage @ +25°C**

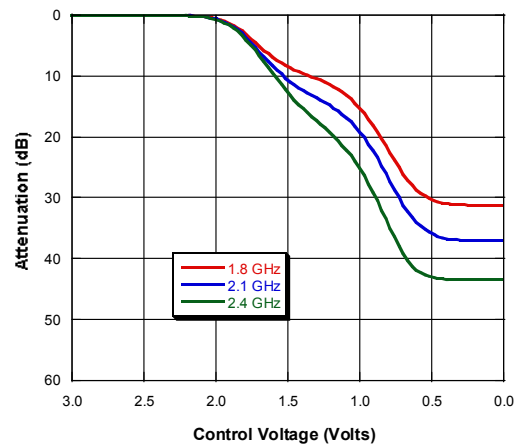

**Typical Device Variation, 2.4 GHz**

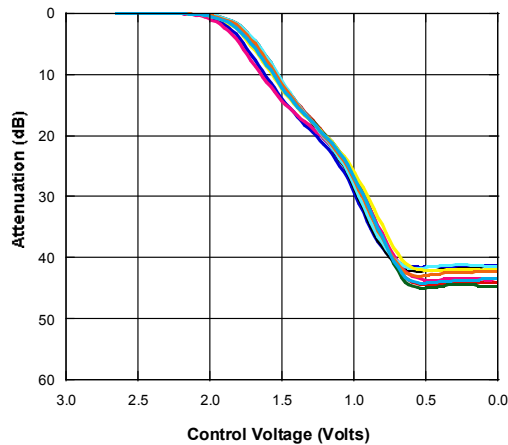

**Attenuation vs. Frequency @ 0.0 V Control Voltage**

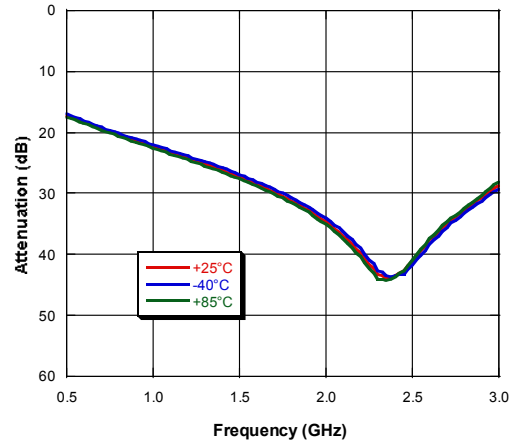

**Return Loss vs. Control Voltage**

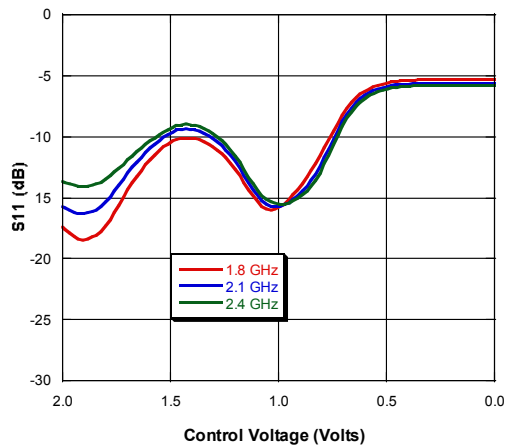

**Insertion Loss Delta Normalized to +25°C (-40°C)**

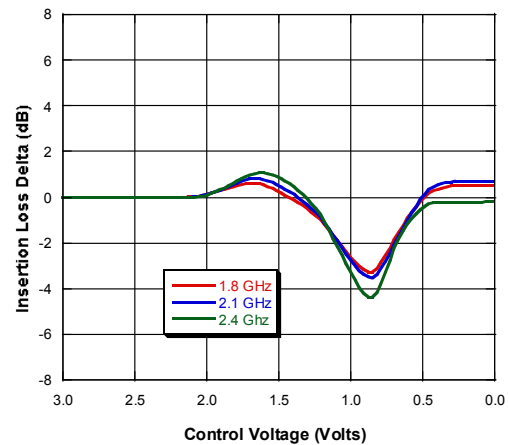

## Typical Performance Curves

**Insertion Loss Delta Normalized to +25°C (+85°C)**

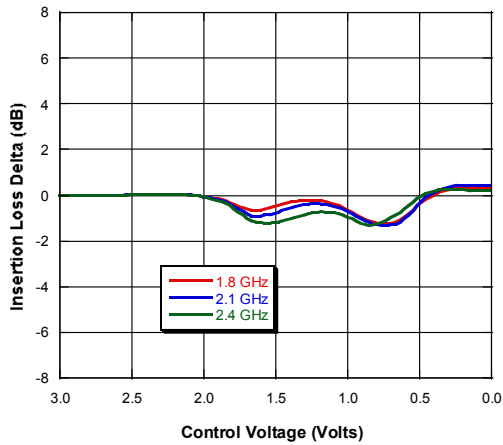

**Input IP3 vs. Control Voltage @ +25°C**

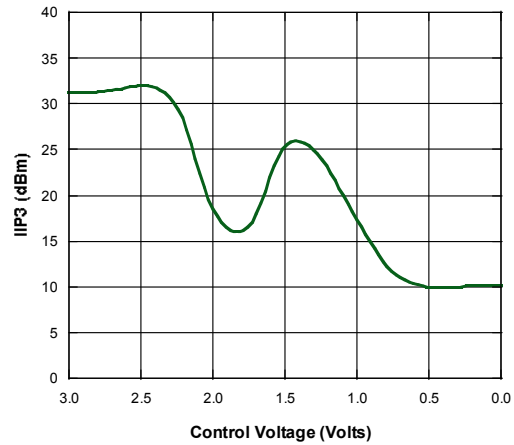

**Input Power for 1 dB Change in Attenuation**

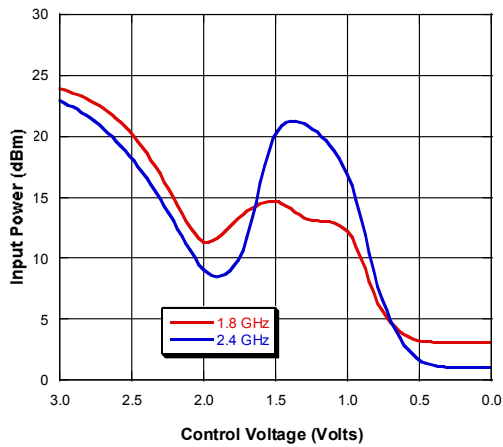

**Input IP3 vs. Control Voltage over Temperature**

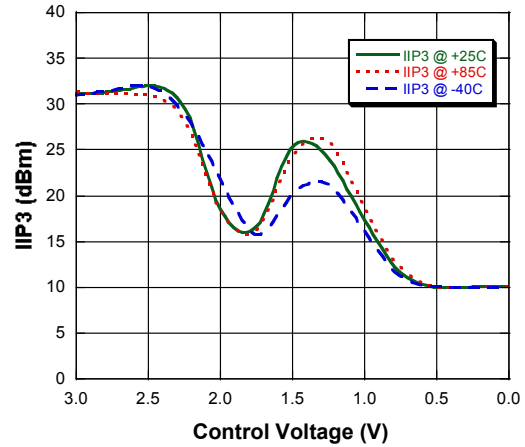

## 2.25 V Voltage Variable Absorptive Attenuator, 42 dB 1.8 - 2.5 GHz

Rev. V3

### Lead-Free SOT-25<sup>†</sup>

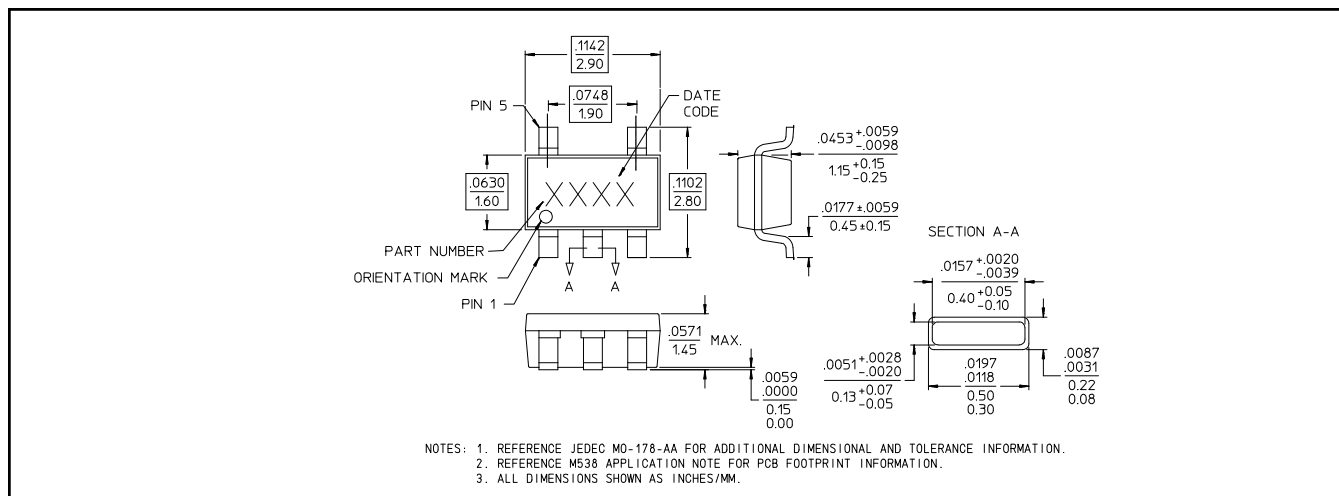

<sup>†</sup> Reference Application Note M538 for lead-free solder reflow recommendations.

M/A-COM Technology Solutions Inc. All rights reserved.

Information in this document is provided in connection with M/A-COM Technology Solutions Inc ("MACOM") products. These materials are provided by MACOM as a service to its customers and may be used for informational purposes only. Except as provided in MACOM's Terms and Conditions of Sale for such products or in any separate agreement related to this document, MACOM assumes no liability whatsoever. MACOM assumes no responsibility for errors or omissions in these materials. MACOM may make changes to specifications and product descriptions at any time, without notice. MACOM makes no commitment to update the information and shall have no responsibility whatsoever for conflicts or incompatibilities arising from future changes to its specifications and product descriptions. No license, express or implied, by estoppel or otherwise, to any intellectual property rights is granted by this document.

THESE MATERIALS ARE PROVIDED "AS IS" WITHOUT WARRANTY OF ANY KIND, EITHER EXPRESS OR IMPLIED, RELATING TO SALE AND/OR USE OF MACOM PRODUCTS INCLUDING LIABILITY OR WARRANTIES RELATING TO FITNESS FOR A PARTICULAR PURPOSE, CONSEQUENTIAL OR INCIDENTAL DAMAGES, MERCHANTABILITY, OR INFRINGEMENT OF ANY PATENT, COPYRIGHT OR OTHER INTELLECTUAL PROPERTY RIGHT. MACOM FURTHER DOES NOT WARRANT THE ACCURACY OR COMPLETENESS OF THE INFORMATION, TEXT, GRAPHICS OR OTHER ITEMS CONTAINED WITHIN THESE MATERIALS. MACOM SHALL NOT BE LIABLE FOR ANY SPECIAL, INDIRECT, INCIDENTAL, OR CONSEQUENTIAL DAMAGES, INCLUDING WITHOUT LIMITATION, LOST REVENUES OR LOST PROFITS, WHICH MAY RESULT FROM THE USE OF THESE MATERIALS.

MACOM products are not intended for use in medical, lifesaving or life sustaining applications. MACOM customers using or selling MACOM products for use in such applications do so at their own risk and agree to fully indemnify MACOM for any damages resulting from such improper use or sale.

## Looking for pricing, stock, or lifecycle information?

Click below to explore more details on WIN SOURCE:

- ⊖ [View MAAVSS0001TR-3000 on WIN SOURCE](#)
- ⊖ [M/A-Com Technology Solutions Information](#)

## Optimize Your Supply Chain with WIN SOURCE Solutions

- ✓ Global Sourcing Solution
- ✓ Obsolete Management
- ✓ Cost Control Management
- ✓ Shortage Management
- ✓ Alternative Solution
- ✓ Excess Inventory Management