



### Features

- Non-Magnetic Package Suitable for MRI Applications
- Rectangular MELF SMQ Ceramic Package
- Hermetically Sealed
- Lower  $R_s$  for Lower Series Loss
- Longer  $\tau_L$  for Lower Intermodulation Distortion
- Lower  $C_j$  for Higher Series Isolation
- Higher Average Incident Power Handling Capability

### Description and Applications

The MA4P7441F-1091T is a surface mountable PIN diode in a Non-Magnetic ( patent pending ) Metal Electrode Leadless Faced (MELF) package. The device incorporates M/A-COM's proven HIPAX technology to produce a low inductance ceramic package with no ribbons or whisker wires. The package utilizes M/A-COM's new non-magnetic plating process to provide an extremely low permeability, hermetically sealed package. Incorporated in the package is a passivated PIN diode that is full face bonded on both the cathode and anode of the chip to maximize surface area for lower electrical and thermal resistance. The MA4P7441F-1091T has been comprehensively characterized both electrically and mechanically to ensure repeatable and predictable performance. This MA4P7441F-1091T Non-Magnetic device is similar in electrical performance to the MA4P4001F-1091T Magnetic part number.

The diodes are well suited for use in low loss, low distortion, and high power switching circuits applicable for high magnetic field environments from HF through UHF frequencies. The lower thermal resistance of this device provides excellent higher average performance at RF power incident levels up to 200 watts CW. This device is designed to meet the most rigorous electrical and mechanical requirements of MRI testing environments.

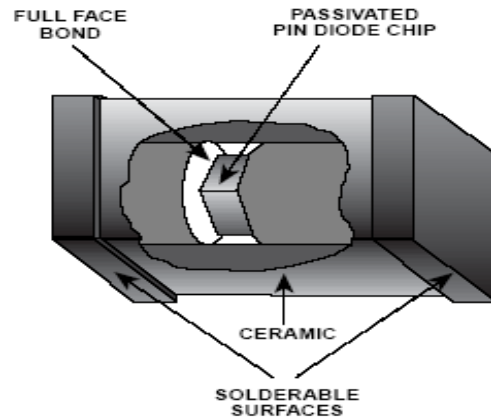

### Designed for Automated Assembly

These SMQ PIN diodes are designed for high volume tape and reel assembly. The rectangular package design provides for highly efficient automatic pick and place assembly techniques. The parallel flat surfaces are suitable for key jaw or vacuum pickup techniques. All solderable surfaces are tin plated and compatible with reflow and vapor phase soldering methods.

### Environmental Capability

HIPAX devices are applicable for use in industrial and military applications and can be screened to meet the environmental requirements of MIL-STD-750, MIL-STD-202 as well as other military standards. The table below lists some of the MIL-STD 750 tests the device is designed to meet.

MIL-STD-750		
Test	Method	Description
High Temperature Storage	1031	+150 °C, for 340 Hours
Temperature Shock	1051	-65 °C to +125 °C, 20 Cycles
HTRB	1038	80% of rated $V_B$ , +150 °C, for 96 Hours
Moisture Resistance	1021	No Initial Conditioning, 85 % RH, +85° C
Gross Leak	1071 Cond. E	Dye Penetrant Visual
Vibration Fatigue	2046	20,000 G's, 60 Hz, x, y, z axis
Solderability	2026	Test Temperature = +245 °C

### Ordering Information

Part Number	Package
MA4P7441F-1091T	Tape and Reel

### Electrical Specifications @ +25 °C

Parameter	Symbol	Condition	Unit Value
Forward Voltage (Maximum)	$V_F$	$I_F = +100 \text{ mA}$	$1.0 V_{DC}$
Voltage Rating (Minimum)	$V_R$	$I_r = -10 \text{ uA}$	$  -100   V_{DC}$
Total Capacitance (Maximum)	$C_T$	$-100 \text{ V @ } 100 \text{ MHz}$	$2.2 \text{ pF}$
Series Resistance (Maximum)	$R_S$	$+100 \text{ mA @ } 100 \text{ MHz}$	$0.5 \text{ Ohms}$
Parallel Resistance (Minimum)	$R_P$	$-10 \text{ V @ } 100 \text{ MHz}$	$10 \text{ K}\Omega$
Carrier Lifetime (Nominal)	$\tau_L$	$+6 \text{ mA} / -10 \text{ mA @}$ $(50\% - 90\% \text{ Voltage})$	$18 \text{ us}$
I-Region Length (Nominal)	$\mu\text{m}$	-	$175 \mu\text{m}$
C.W. Thermal Resistance (Maximum)	$\theta$	$I_H = 1\text{A}, I_L = 10 \text{ mA},$ $T = 1 \text{ mS}$	$5 \text{ }^\circ\text{C/W}$
Power Dissipation in Free Air (Maximum)	$W$	$I_F = +100 \text{ mA}$	$9 \text{ W}$
Power Dissipation with Diode Case at Tambient (Maximum)	$P_D$	$I_F = +100 \text{ mA}$	$30 \text{ W}$

### Absolute Maximum Ratings<sup>1</sup> @ 25°C

Parameter	Absolute Maximum
Operating Temperature	$-65 \text{ }^\circ\text{C}$ to $+125 \text{ }^\circ\text{C}$
Storage Temperature	$-65 \text{ }^\circ\text{C}$ to $+150 \text{ }^\circ\text{C}$
Diode Junction Temperature	$+175 \text{ }^\circ\text{C}$ Continuous
Diode Mounting Temperature	$+235 \text{ }^\circ\text{C}$ for 10 seconds
RF C.W. Incident Power	$+ 53 \text{ dBm C.W.}$
Forward D.C. Current	$+ 500 \text{ mA}$
Reverse D.C. Voltage @ $-10 \text{ uA}$	$  - 150 \text{ V}  $

1. Exceeding these limits may cause permanent damage.

## Mechanical Outline

Case Style	Dimensions in Inches (mm)		
	A Square Min / Max	B Min / Max	C Min / Max
1091	0.138 / 0.155 (3.50/ 3.94)	0.180 / 0.200 (4.57/ 5.08)	0.008 / 0.030 (.203 / .762)

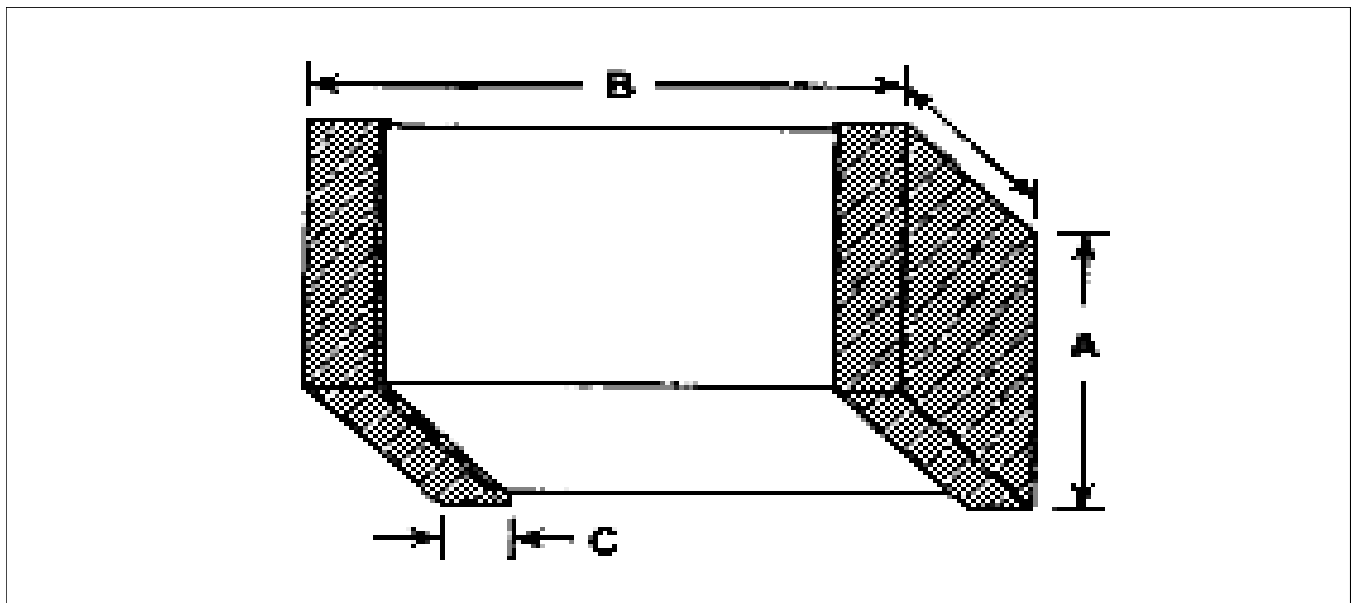

### Typical Electrical Performance

MA4P7441F-1091T  $R_s$  vs I

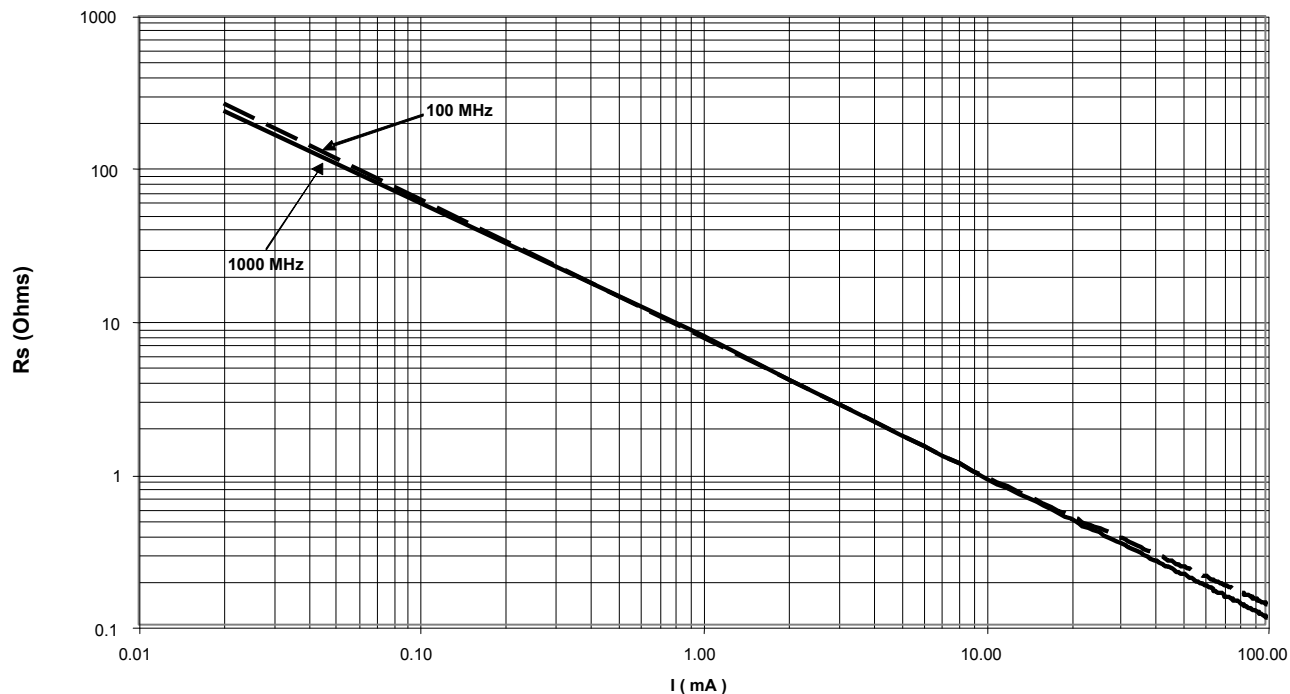

MA4P7441F-1091T  $R_p$  vs Voltage

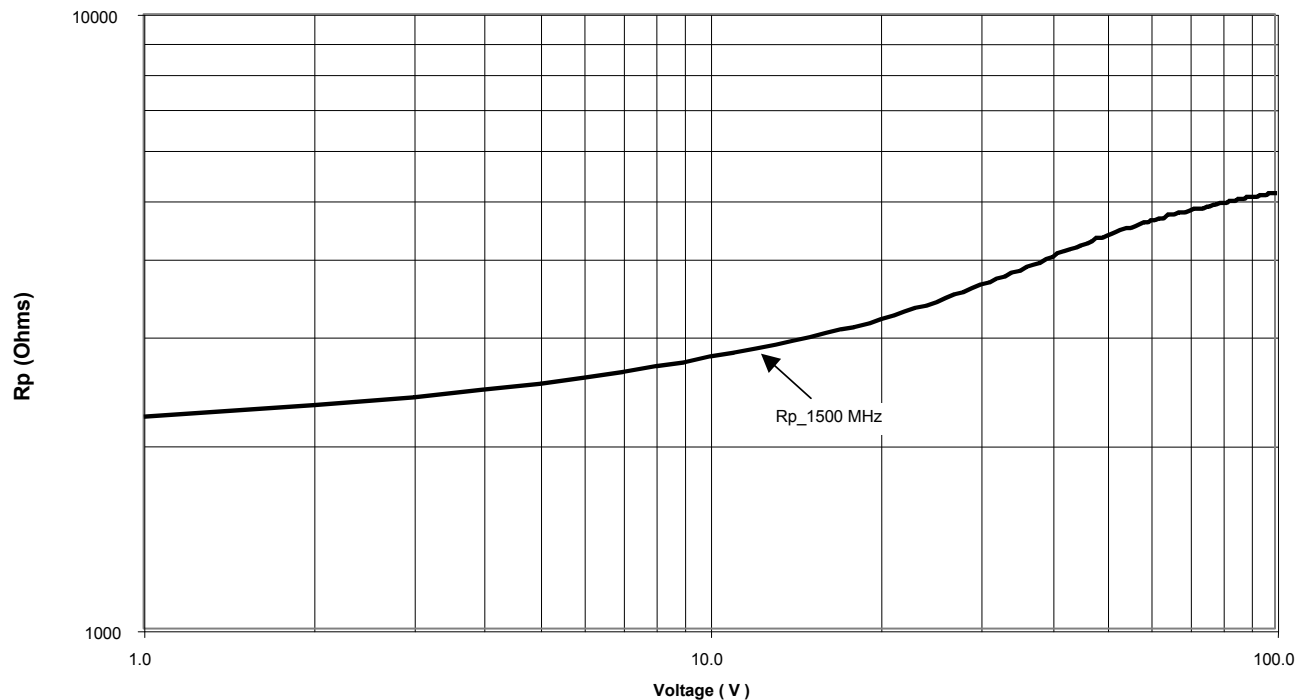

### Typical Electrical Performance

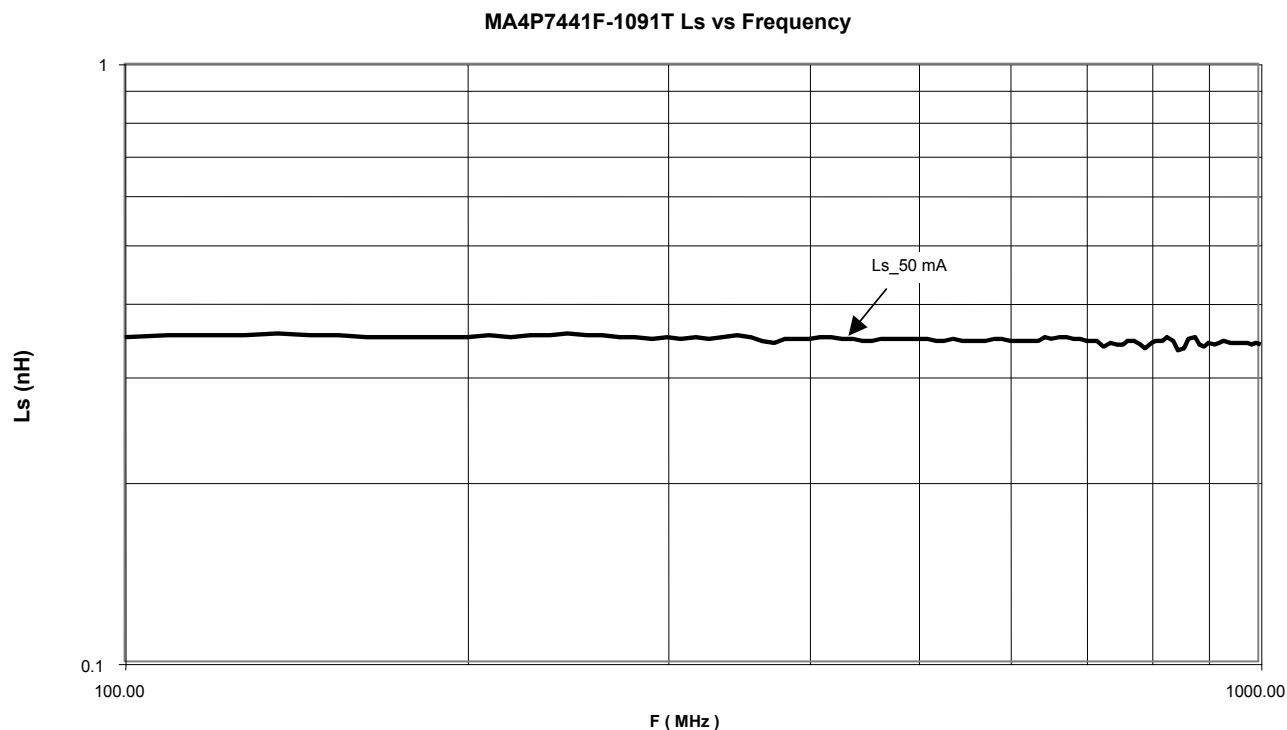
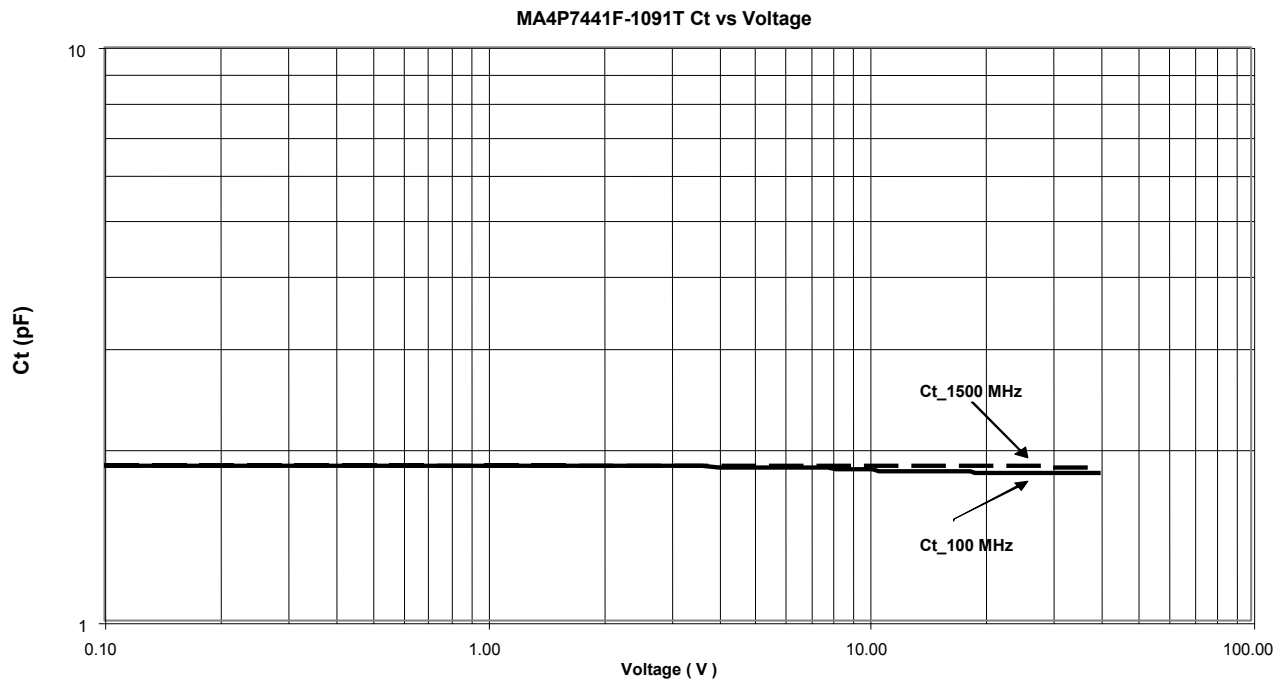

## Typical Non-Magnetic Performance

Comparison of Magnetic Moment for MA4P7400F-1091T Non-Magnetic & MA4P4001F-1091T Magnetic Devices

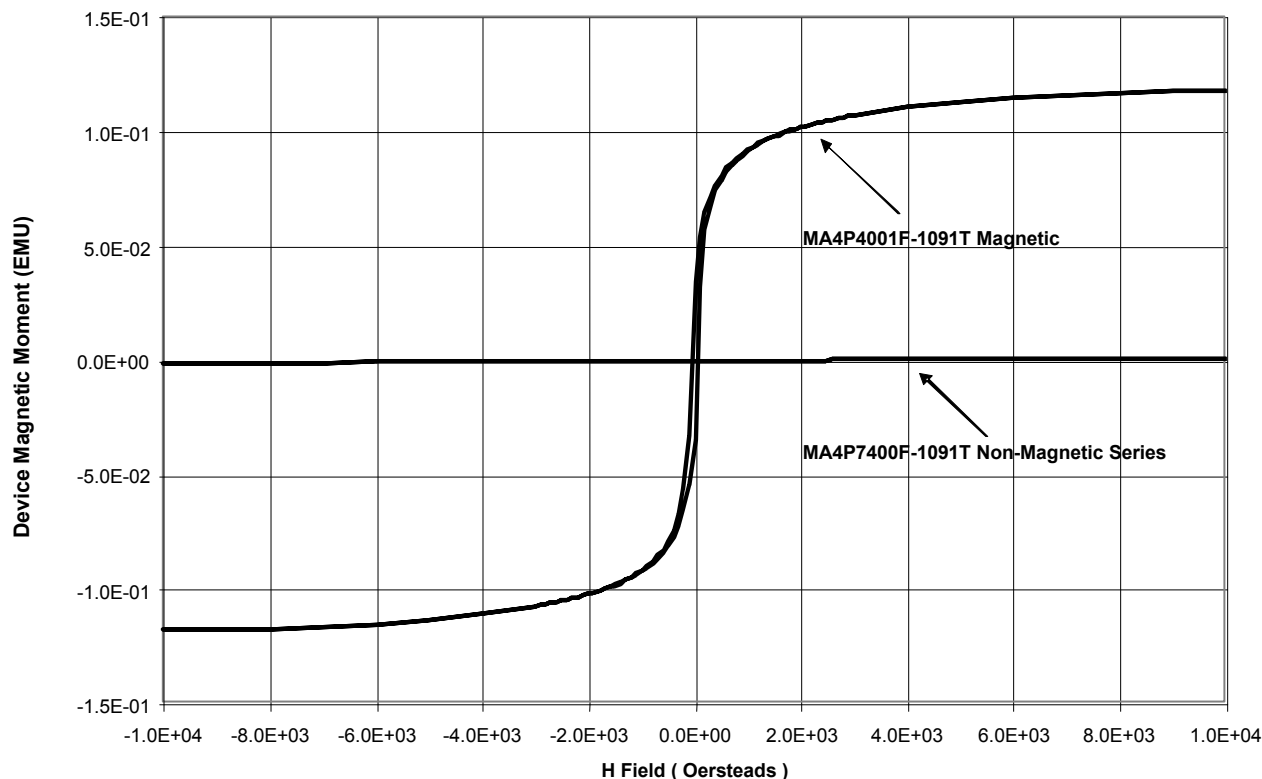

Table 1 - Typical Magnetic Properties of Non-Magnetic MA4P7441F-1091T Device Vs. Conventional MA4P4001F-1091T Magnetic Device

Magnetic Property	MA4P7441F-1091T Value	MA4P4001-1091T Value
Saturation Moment (EMU) @ H = H <sub>MAX</sub> Oersteds	1.0 x E-3	1.2 x E-1
Remanance Moment (EMU) @ H = 0 Oersteds	1.5 x E-6	3.4 x E-2
Coercivity (Oersteds) @ EMU = 0 Moment	3.0	51.3

M/A-COM Technology Solutions Inc. All rights reserved.

Information in this document is provided in connection with M/A-COM Technology Solutions Inc ("MACOM") products. These materials are provided by MACOM as a service to its customers and may be used for informational purposes only. Except as provided in MACOM's Terms and Conditions of Sale for such products or in any separate agreement related to this document, MACOM assumes no liability whatsoever. MACOM assumes no responsibility for errors or omissions in these materials. MACOM may make changes to specifications and product descriptions at any time, without notice. MACOM makes no commitment to update the information and shall have no responsibility whatsoever for conflicts or incompatibilities arising from future changes to its specifications and product descriptions. No license, express or implied, by estoppel or otherwise, to any intellectual property rights is granted by this document.

THESE MATERIALS ARE PROVIDED "AS IS" WITHOUT WARRANTY OF ANY KIND, EITHER EXPRESS OR IMPLIED, RELATING TO SALE AND/OR USE OF MACOM PRODUCTS INCLUDING LIABILITY OR WARRANTIES RELATING TO FITNESS FOR A PARTICULAR PURPOSE, CONSEQUENTIAL OR INCIDENTAL DAMAGES, MERCHANTABILITY, OR INFRINGEMENT OF ANY PATENT, COPYRIGHT OR OTHER INTELLECTUAL PROPERTY RIGHT. MACOM FURTHER DOES NOT WARRANT THE ACCURACY OR COMPLETENESS OF THE INFORMATION, TEXT, GRAPHICS OR OTHER ITEMS CONTAINED WITHIN THESE MATERIALS. MACOM SHALL NOT BE LIABLE FOR ANY SPECIAL, INDIRECT, INCIDENTAL, OR CONSEQUENTIAL DAMAGES, INCLUDING WITHOUT LIMITATION, LOST REVENUES OR LOST PROFITS, WHICH MAY RESULT FROM THE USE OF THESE MATERIALS.

MACOM products are not intended for use in medical, lifesaving or life sustaining applications. MACOM customers using or selling MACOM products for use in such applications do so at their own risk and agree to fully indemnify MACOM for any damages resulting from such improper use or sale.

## Looking for pricing, stock, or lifecycle information?

Click below to explore more details on WIN SOURCE:

- ⊖ [View MA4P7441F-1091T on WIN SOURCE](#)
- ⊖ [M/A-Com Technology Solutions Information](#)

## Optimize Your Supply Chain with WIN SOURCE Solutions

- ✓ Global Sourcing Solution
- ✓ Obsolete Management
- ✓ Cost Control Management
- ✓ Shortage Management
- ✓ Alternative Solution
- ✓ Excess Inventory Management