

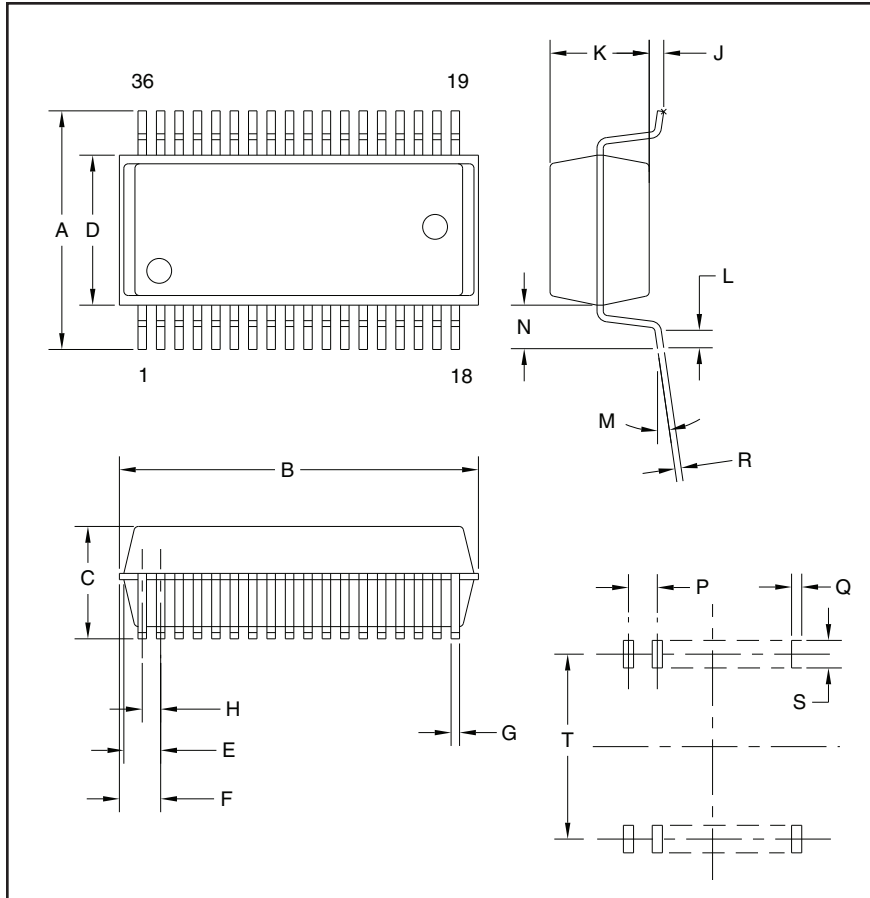

**THE DATASHEET OF
M63993FP**



HVIC 3-Phase Bridge Driver



Outline Drawing and Pin Diagram

Dimensions	Inches	Millimeters
A	0.47	11.93±0.3
B	0.59	15.0±0.2
C	0.09 Max.	2.35 Max.
D	0.33	8.4±0.2
E	0.03	0.7
F	0.03 Max.	0.85 Max.
G	0.01	0.35+0.1/-0.05
H	0.03	0.8
J	0.004	0.1±0.1

Dimensions	Inches	Millimeters
K	0.08	2.05
L	0.02	0.5±0.2
M	8° Max.	8° Max.
N	0.07	1.765
P	0.03	0.8
Q	0.02	0.5
R	0.01	0.2+0.05/-0.02
S	0.05 Min.	1.27 Min.
T	0.45 Min.	11.43 Min.

Description:

M63993FP is a high voltage, Power MOSFET/IGBT module driver for 3-Phase bridge applications.

Features:

- 600V Floating Supply Voltage
- ±300mA Output Current
- 3-Phase Bridge Driver
- SSOP-36 Package

Applications:

- Appliances
- Air Conditioners
- AC Servo Motors
- General Purpose Power Supplies



Powerex, Inc., 173 Pavilion Lane, Youngwood, Pennsylvania 15697 (724) 925-7272

M63993FP
HVIC 3-Phase Bridge Driver

Absolute Maximum Ratings, $T_a = 25^\circ\text{C}$ unless otherwise specified

Ratings	Symbol	Test Conditions	M63993FP	Units
High Side Floating Supply Voltage	U,V,W _{FB}		-0.5 ~ 624	Volts
High Side Floating Supply Offset Voltage	U,V,W _{FS}		V _B -24/+0.5	Volts
High Side Output Voltage	V _U ,V,W _{PO}		V _S -0.5 ~ V _B +0.5	Volts
Low Side Fixed Supply Voltage	V _{CC}		-0.5 ~ 24	Volts
Low Side Output Voltage	V _U ,V,W _{NO}		-0.5 ~ V _{CC} +0.5	Volts
Logic Supply Voltage	V _{DD}		-0.5 ~ 7	Volts
Logic Input Voltage	V _{IN}	U,V,W _{PIN} , U,V,W _{NIN}	-0.5 ~ V _{DD} +0.5	Volts
Allowable Offset Supply Voltage Transient	dV _S /dt		±50	V/ns
Package Power Dissipation	P _t	T _a = 25°C, On Board	1.2	W
Linear Derating Factor	K θ	T _a > 25°C, On Board	12.0	mW/°C
Junction Case Thermal Resistance	R _{th(j-c)}		30	°C/W
Junction Temperature	T _j		-30 ~ 125	°C
Operation Temperature	T _{opr}		-30 ~ 100	°C
Storage Temperature	T _{stg}		-40 ~ 125	°C

Recommended Operating Conditions

Parameter	Symbol	Test Conditions	Min.	Typ.	Max.	Units
High Side Floating Supply Voltage	U,V,W _{FB}		V _S +10	—	V _S +20	Volts
High Side Floating Supply Offset Voltage	U,V,W _{FS}		-5	—	500	Volts
Low Side Fixed Supply Voltage	V _{CC}		10	—	20	Volts
Logic Supply Voltage	V _{DD}		4.5	—	5.5	Volts
Logic Input Voltage	V _{IN}	U,V,W _{PIN} , U,V,W _{NIN}	0	—	V _{DD}	Volts
Output Ground Voltage	V _{P_{GND}}		-5	—	5	Volts

Function Table 1 (Input, Output and U_V)

U,V,W _{PIN}	U,V,W _{NIN}	U _V	U,V,W _{PO}	U,V,W _{NO}	Behavioral State
H	H	H	L	L	Normal OFF
H	L	H	L	H	*NO ON
L	H	H	H	L	*PO ON
L	L	X	L	L	*PO = OFF, *NO = OFF, *P _{IN} = *N _{IN} = L Simultaneously
X	H	L	L	L	*PO OFF, *V _B U _V Tripped
H	L	L	L	H	*NO ON, *V _B U _V Tripped

* Note: "L" state of *V_B U_V means that UV trip voltage.

Function Table 2 (Comparator)

C _{IN1}	C _{IN2}	C _{OUT}	Behavioral State
L	H	H	C _{OUT} is Normal HIGH
H	X	L	
X	L	L	

M63993FP
HVIC 3-Phase Bridge Driver

Electrical Characteristics, $T_a = 25^\circ\text{C}$, $V_{CC} = V_{BS} = 15\text{V}$, $V_{DD} = 5\text{V}$ unless otherwise specified

Parameter	Symbol	Test Conditions	Min.	Typ.*	Max.	Units
Floating Supply Leakage Current	I_{FS}	$V_B = V_S = 600\text{V}$ per 1-Phase	—	—	1	μA
V_{BS} Standby Current	I_{BS}		—	0.48	—	mA
V_{CC} Standby Current	I_{CC}		—	—	0.1	mA
V_{DD} Standby Current	I_{DD}		—	0.5	—	μA
High Level Output Voltage	V_{OH}	$I_O = 0\text{A}$, *NO, *PO	14.9	—	—	Volts
Low Level Output Voltage	V_{OL}	$I_O = 0\text{A}$, *NO, *PO	—	—	0.1	Volts
High Level Input Threshold Voltage	V_{IH}	*P _{IN} , *N _{IN}	2.1	3.0	4.0	Volts
Low Level Input Threshold Voltage	V_{IL}	*P _{IN} , *N _{IN}	0.6	1.5	1.9	Volts
High Level Input Bias Current	I_{IH}	*P _{IN} , *N _{IN} = 5V	—	—	1.0	μA
Low Level Input Bias Current	I_{IL}	*P _{IN} , *N _{IN} = 0V	—	100	300	μA
V_{BS} Supply U_V Trip Voltage	V_{UVT}		7.0	8.0	9.0	Volts
V_{BS} Supply U_V Reset Voltage	V_{UVR}		7.5	8.5	9.5	Volts
V_{BS} Supply Filter Time	t_{UV}		—	7.5	—	μs
Output High Level Short Circuit Pulsed Current	I_{OH}	*P _O , *N _O = 0V, *P _{IN} , *N _{IN} = 5V, $P_W < 10\mu\text{s}$	—	-300	—	mA
Output Low Level Short Circuit Pulsed Current	I_{OL}	*P _O , *N _O = 15V, *P _{IN} , *N _{IN} = 0V, $P_W < 10\mu\text{s}$	—	300	—	mA
High Side Turn-On Propagation Delay	$t_{dLH}(\text{HO})$		250	300	350	ns
High Side Turn-Off Propagation Delay	$t_{dHL}(\text{HO})$	$CL = 1000\text{pF}$ between HO – V_S	230	280	330	ns
High Side Turn-On Rise Time	$t_r(\text{HO})$		—	130	—	ns
High Side Turn-Off Fall Time	$t_f(\text{HO})$		—	100	—	ns
Low Side Turn-On Propagation Delay	$t_{dLH}(\text{LO})$		250	300	350	ns
Low Side Turn-Off Propagation Delay	$t_{dHL}(\text{LO})$	$CL = 1000\text{pF}$ between LO – GND	230	280	330	ns
Low Side Turn-On Rise Time	$t_r(\text{LO})$		—	130	—	ns
Low Side Turn-Off Fall Time	$t_f(\text{LO})$		—	100	—	ns
Comparator 1 Threshold Voltage	V_{CIN1th}	$V_{DD} = 5\text{V}$	0.47	0.5	0.53	Volts
Comparator 1 Filter Time	t_{VCIN1}		—	1.5	—	μs
Comparator 2 Threshold Voltage	V_{CIN2th}	$V_{DD} = 5\text{V}$	2.4	2.5	2.6	Volts
Comparator 2 Filter Time	t_{VCIN2}		—	7.5	—	μs
Comparator H Level Output Voltage	V_{COH}	$I_{CO} = 500\mu\text{A}$	4.5	—	—	Volts
Comparator L Level Output Voltage	V_{COL}	$I_{CO} = 500\mu\text{A}$	—	—	0.5	Volts

* The typical values are those measured under ambient temperature (T_a) of 25°C .
 There is no guarantee that these values are obtained under any conditions.

M63993FP
HVIC 3-Phase Bridge Driver

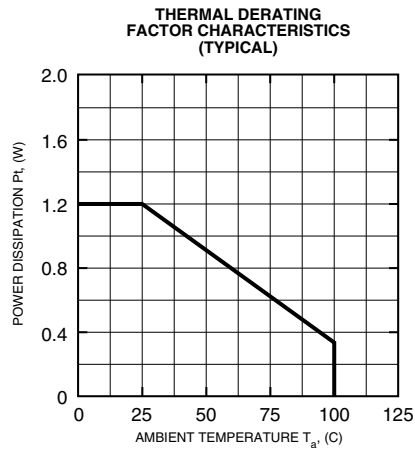

BLOCK DIAGRAM

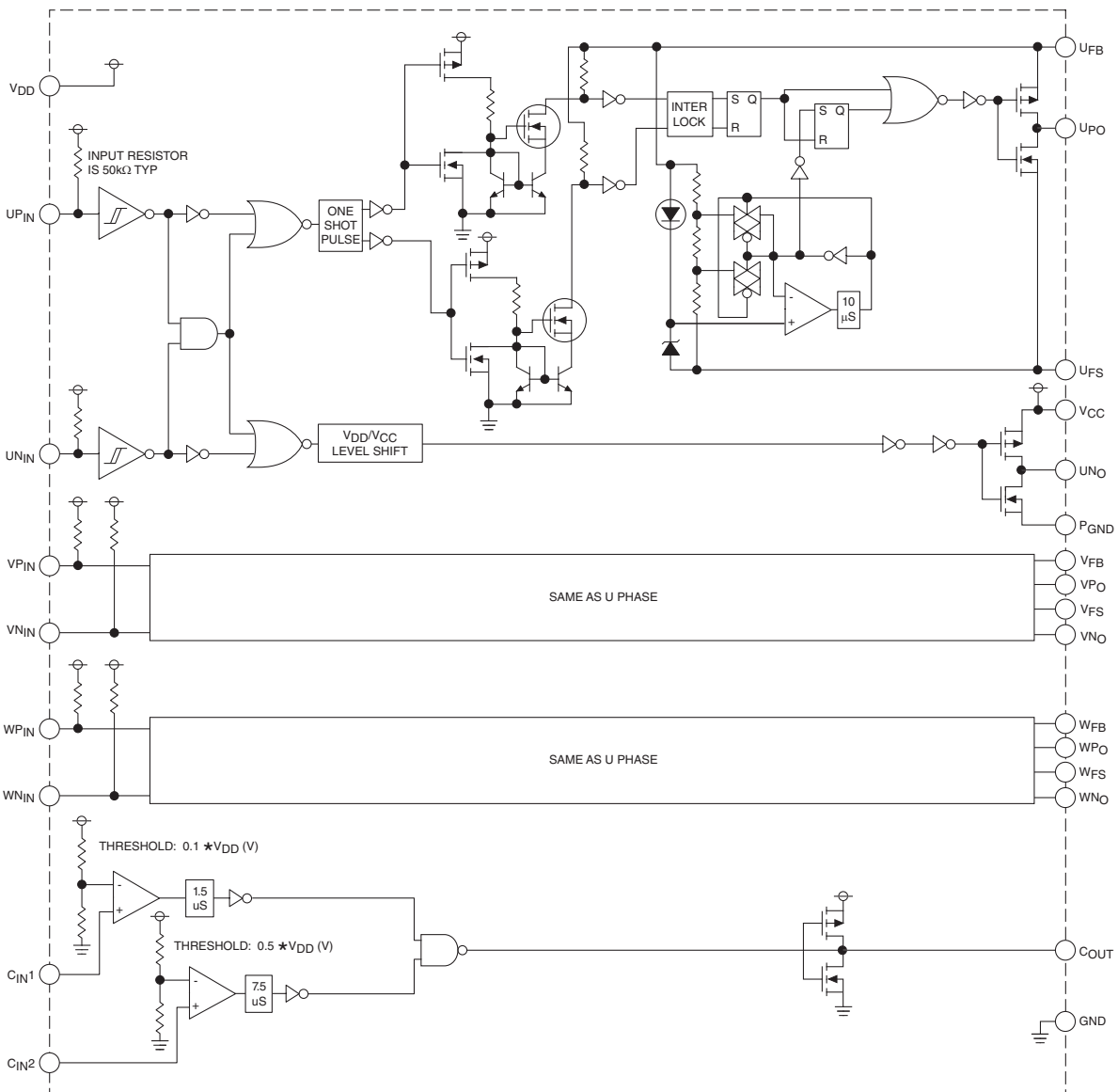

Looking for pricing, stock, or lifecycle information?

Click below to explore more details on WIN SOURCE:

 [View M63993FP on WIN SOURCE](#)

 [Powerex Inc. Information](#)

Optimize Your Supply Chain with WIN SOURCE Solutions

-  Global Sourcing Solution
-  Obsolete Management
-  Cost Control Management
-  Shortage Management
-  Alternative Solution
-  Excess Inventory Management