



**THE DATASHEET OF
M48T59Y-70MH1E**



5.0 or 3.3 V, 64 Kbit (8 Kbit x 8) TIMEKEEPER[®] SRAM

Not For New Design

Features

- Integrated ultra low power SRAM, real-time clock, power-fail control circuit, and battery
- Frequency test output for real-time clock software calibration
- Automatic power-fail chip deselect and WRITE protection
- WRITE protect voltages (V_{PFD} = Power-fail deselect voltage):
 - M48T59: $V_{CC} = 4.75$ to 5.5 V
 4.5 V $\leq V_{PFD} \leq 4.75$ V
 - M48T59Y: $V_{CC} = 4.5$ to 5.5 V
 4.2 V $\leq V_{PFD} \leq 4.5$ V
 - M48T59V^(a): $V_{CC} = 3.0$ to 3.6 V
 2.7 V $\leq V_{PFD} \leq 3.0$ V
- Self-contained battery and crystal in the CAPHAT[™] DIP package
- Packaging includes a 28-lead SOIC and SNAPHAT[®] top (to be ordered separately)
- SOIC package provides direct connection for a SNAPHAT top which contains the battery and crystal
- Microprocessor power-on reset (valid even during battery back-up mode)
- Programmable alarm output active in the battery back-up mode
- Battery low flag
- RoHS compliant
 - Lead-free second level interconnect

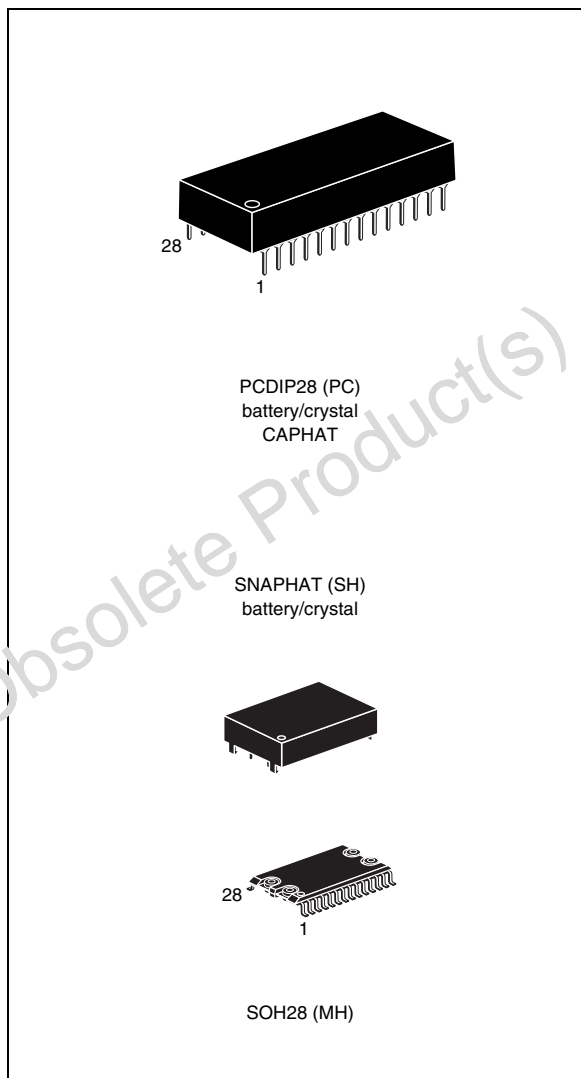

a. Contact local ST sales office for availability of 3.3 V version.

Contents

1	Description	5
2	Operation modes	8
	2.1 Read mode	8
	2.2 Write mode	10
	2.3 Data retention mode	11
3	Clock operations	12
	3.1 Reading the clock	12
	3.2 Setting the clock	12
	3.3 Stopping and starting the oscillator	12
	3.4 Calibrating the clock	14
	3.5 Setting the alarm clock	15
	3.6 Watchdog timer	17
	3.7 Power-on reset	18
	3.8 Programmable interrupts	18
	3.9 Battery low flag	18
	3.10 Century bit	19
	3.11 Initial power-on defaults	19
	3.12 V_{CC} noise and negative going transients	19
4	Maximum ratings	21
5	DC and AC parameters	22
6	Package mechanical data	25
7	Part numbering	29
8	Revision history	31

List of tables

Table 1.	Signal names	6
Table 2.	Operating modes	8
Table 3.	Read mode AC characteristics	9
Table 4.	Write mode AC characteristics	11
Table 5.	Register map	13
Table 6.	Alarm repeat mode	16
Table 7.	Default values	19
Table 8.	Absolute maximum ratings	21
Table 9.	Operating and AC measurement conditions	22
Table 10.	Capacitance	22
Table 11.	DC characteristics	23
Table 12.	Power down/up AC characteristics	24
Table 13.	Power down/up trip points DC characteristics	24
Table 14.	PCDIP28 – 28-pin plastic DIP, battery CAPHAT, package mechanical data	25
Table 15.	SOH28 – 28-lead plastic small outline, battery SNAPHAT, pack. mech. data	26
Table 16.	SH – 4-pin SNAPHAT housing for 48mAh battery & crystal, package mech. data	27
Table 17.	SH – 4-pin SNAPHAT housing for 120mAh battery & crystal, package mech. data	28
Table 18.	Ordering information scheme	29
Table 19.	SNAPHAT battery table	30
Table 20.	Document revision history	31

List of figures

Figure 1.	Logic diagram	5
Figure 2.	28-pin SOIC connections	6
Figure 3.	PCDIP28 CAPHAT connections	6
Figure 4.	Block diagram	7
Figure 5.	Read mode AC waveforms	9
Figure 6.	Write enable controlled, write mode AC waveforms	10
Figure 7.	Chip enable controlled, write mode AC waveforms	10
Figure 8.	Crystal accuracy across temperature	15
Figure 9.	Clock calibration	15
Figure 10.	Alarm interrupt reset waveform	16
Figure 11.	Back-up mode alarm waveforms	17
Figure 12.	Supply voltage protection	20
Figure 13.	AC measurement load circuit	22
Figure 14.	Power down/up mode AC waveforms	23
Figure 15.	PCDIP28 – 28-pin plastic DIP, battery CAPHAT, package outline	25
Figure 16.	SOH28 – 28-lead plastic small outline, battery SNAPHAT, package outline	26
Figure 17.	SH – 4-pin SNAPHAT housing for 48mAh battery & crystal, package outline	27
Figure 18.	SH – 4-pin SNAPHAT housing for 120mAh battery & crystal, package outline	28

1 Description

The M48T59/Y/V TIMEKEEPER[®] RAM is an 8 Kb x 8 non-volatile static RAM and real-time clock. The monolithic chip is available in two special packages to provide a highly integrated battery backed-up memory and real-time clock solution.

The M48T59/Y/V is a non-volatile pin and function equivalent to any JEDEC standard 8 Kb x8 SRAM. It also easily fits into many ROM, EPROM, and EEPROM sockets, providing the non-volatility of PROMs without any requirement for special write timing or limitations on the number of writes that can be performed.

The 28-pin, 600 mil DIP CAPHAT[™] houses the M48T59/Y/V silicon with a quartz crystal and a long life lithium button cell in a single package.

The 28-pin, 330 mil SOIC provides sockets with gold plated contacts at both ends for direct connection to a separate SNAPHAT[®] housing containing the battery and crystal. The unique design allows the SNAPHAT battery package to be mounted on top of the SOIC package after the completion of the surface mount process. Insertion of the SNAPHAT housing after reflow prevents potential battery and crystal damage due to the high temperatures required for device surface-mounting. The SNAPHAT housing is keyed to prevent reverse insertion.

The SOIC and battery/crystal packages are shipped separately in plastic anti-static tubes or in Tape & Reel form. For the 28-lead SOIC, the battery/crystal package (e.g., SNAPHAT) part number is "M4T28-BR12SH1" or "M4T32-BR12SHx" (see [Table 19 on page 30](#)).

Caution: Do not place the SNAPHAT battery/crystal top in conductive foam, as this will drain the lithium button-cell battery.

Figure 1. Logic diagram

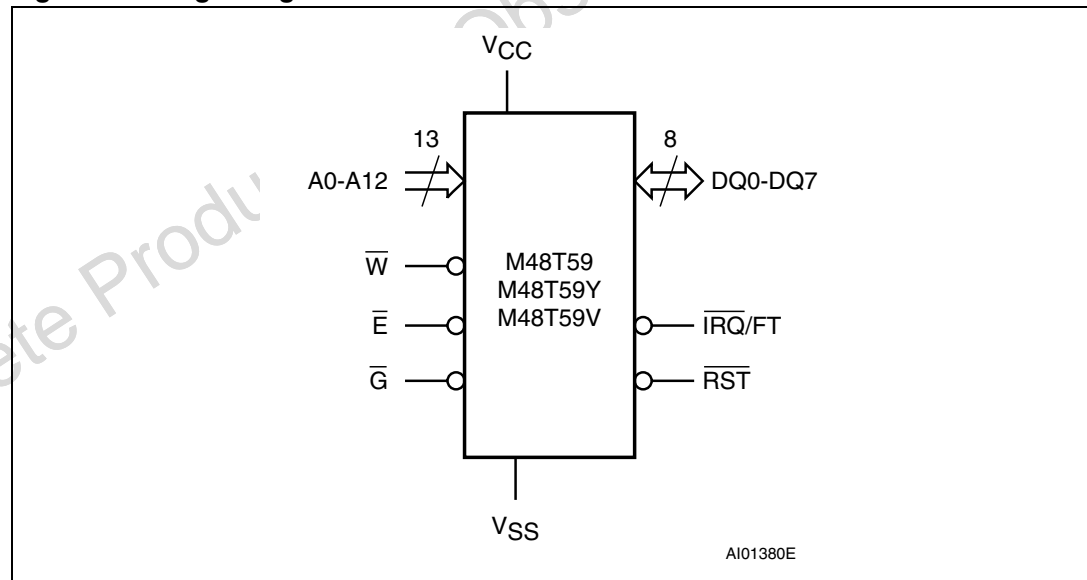

Table 1. Signal names

A0-A12	Address inputs
DQ0-DQ7	Data inputs / outputs
$\overline{\text{IRQ/FT}}$	Interrupt / frequency test output (open drain)
$\overline{\text{RST}}$	Reset output (open drain)
$\overline{\text{E}}$	Chip enable
$\overline{\text{G}}$	Output enable
$\overline{\text{W}}$	Write enable
V_{CC}	Supply voltage
V_{SS}	Ground

Figure 2. 28-pin SOIC connections

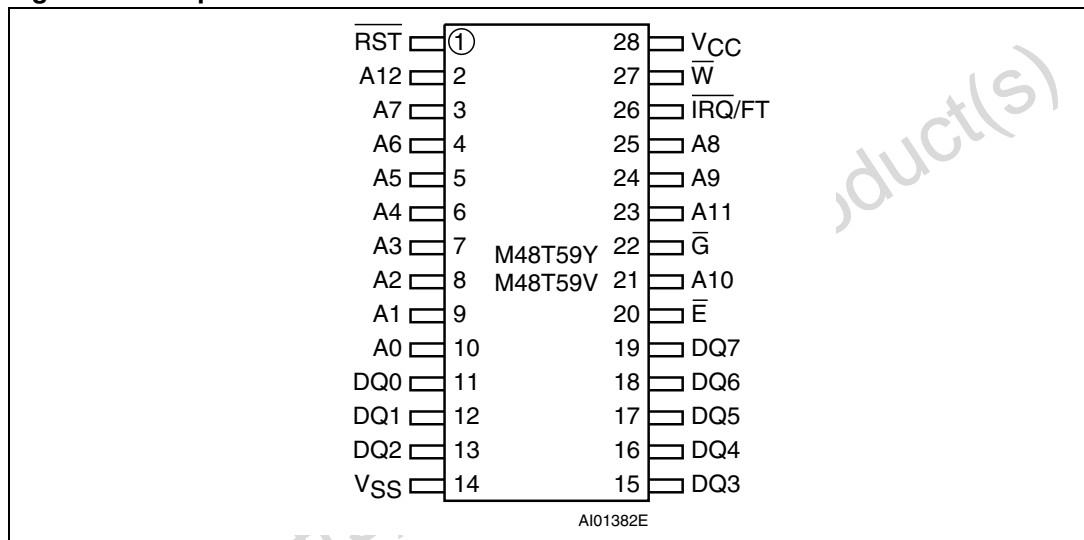

Figure 3. PCDIP28 CAPHAT connections

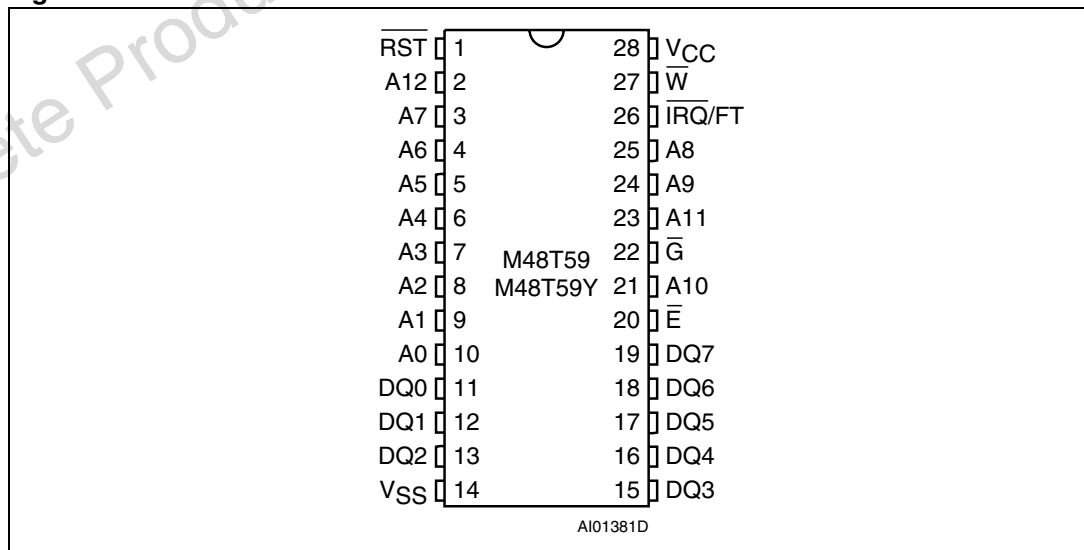
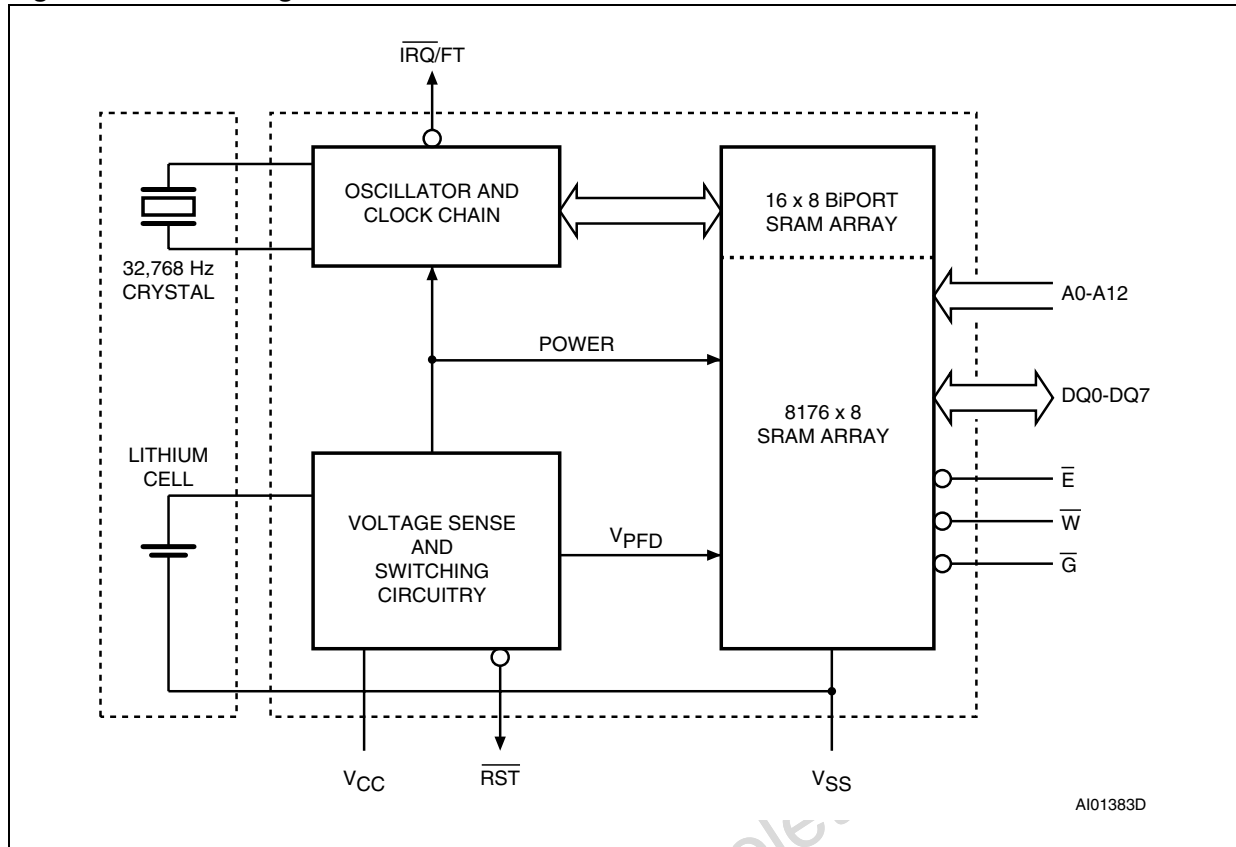

Figure 4. Block diagram



Obsolete Product(s) - Obsolete

2 Operation modes

As [Figure 4 on page 7](#) shows, the static memory array and the quartz-controlled clock oscillator of the M48T59/Y/V are integrated on one silicon chip.

The two circuits are interconnected at the upper eight memory locations to provide user accessible BYTEWIDE™ clock information in the bytes with addresses 1FF8h-1FFFh. The clock locations contain the century, year, month, date, day, hour, minute, and second in 24 hour BCD format (except for the century). Corrections for 28, 29 (leap year - valid until 2100), 30, and 31 day months are made automatically. Byte 1FF8h is the clock control register. This byte controls user access to the clock information and also stores the clock calibration setting.

The eight clock bytes are not the actual clock counters themselves; they are memory locations consisting of BIOPORT™ READ/WRITE memory cells. The M48T59/Y/V includes a clock control circuit which updates the clock bytes with current information once per second. The information can be accessed by the user in the same manner as any other location in the static memory array.

The M48T59/Y/V also has its own Power-fail Detect circuit. The control circuitry constantly monitors the single 5V/3.3 V supply for an out of tolerance condition. When V_{CC} is out of tolerance, the circuit write protects the SRAM, providing a high degree of data security in the midst of unpredictable system operation brought on by low V_{CC} . As V_{CC} falls below the Battery Back-up Switchover Voltage (V_{SO}), the control circuitry connects the battery which maintains data and clock operation until valid power returns.

Table 2. Operating modes

Mode	V_{CC}	E	G	W	DQ7-DQ0	Power
Deselect	4.75 to 5.5 V or 4.5 to 5.5 V or 3.0 to 3.6 V	V_{IH}	X	X	High Z	Standby
WRITE		V_{IL}	X	V_{IL}	D_{IN}	Active
READ		V_{IL}	V_{IL}	V_{IH}	D_{OUT}	Active
READ		V_{IL}	V_{IH}	V_{IH}	High Z	Active
Deselect	V_{SO} to V_{PFD} (min) ⁽¹⁾⁽¹⁾	X	X	X	High Z	CMOS standby
Deselect	$\leq V_{SO}$ ⁽¹⁾	X	X	X	High Z	Battery back-up mode

1. See [Table 13 on page 24](#) for details.

Note: $X = V_{IH}$ or V_{IL} ; V_{SO} = Battery back-up switchover voltage.

2.1 Read mode

The M48T59/Y/V is in the READ Mode whenever \overline{W} (WRITE Enable) is high and \overline{E} (Chip Enable) is low. The unique address specified by the 13 address inputs defines which one of the 8,192 bytes of data is to be accessed. Valid data will be available at the Data I/O pins within Address Access time (t_{AVQV}) after the last address input signal is stable, providing that the \overline{E} and \overline{G} access times are also satisfied. If the \overline{E} and \overline{G} access times are not met, valid data will be available after the latter of the Chip Enable Access time (t_{ELQV}) or Output Enable Access time (t_{GLQV}).

The state of the eight three-state Data I/O signals is controlled by \bar{E} and \bar{G} . If the outputs are activated before t_{AVQV} , the data lines will be driven to an indeterminate state until t_{AVQV} . If the Address Inputs are changed while \bar{E} and \bar{G} remain active, output data will remain valid for Output Data Hold time (t_{AXQX}) but will go indeterminate until the next Address Access.

Figure 5. Read mode AC waveforms

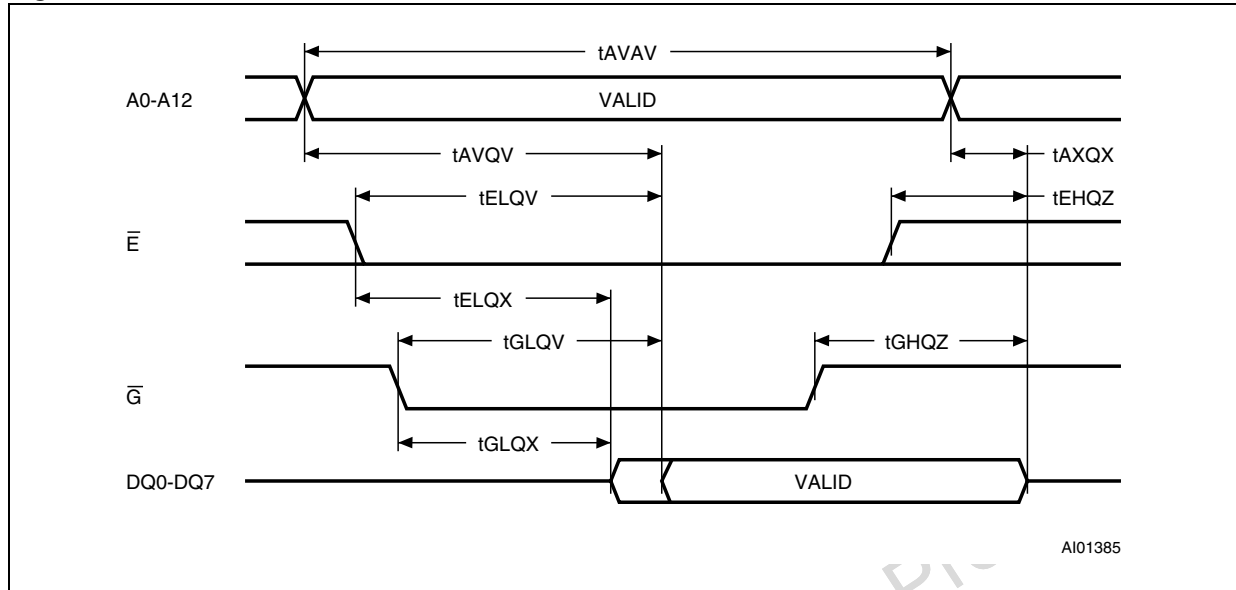

Note: WRITE enable (\bar{W}) = High.

Table 3. Read mode AC characteristics

Symbol	Parameter ⁽¹⁾	M48T59/Y/V		Unit
		-70		
		Min	Max	
t_{AVAV}	READ cycle time	70		ns
$t_{AVQV}^{(2)}$	Address valid to output valid		70	ns
$t_{ELQV}^{(2)}$	Chip enable low to output valid		70	ns
$t_{GLQV}^{(2)}$	Output enable low to output valid		35	ns
$t_{ELQX}^{(3)}$	Chip enable low to output transition	5		ns
$t_{GLQX}^{(3)}$	Output enable low to output transition	5		ns
$t_{EHQZ}^{(3)}$	Chip enable high to output Hi-Z		25	ns
$t_{GHQZ}^{(3)}$	Output enable high to output Hi-Z		25	ns
$t_{AXQX}^{(2)}$	Address transition to output transition	10		ns

1. Valid for ambient operating temperature: $T_A = 0$ to 70°C ; $V_{CC} = 4.5$ to 5.5 V, 4.75 to 5.5 V, or 3.0 to 3.6 V (except where noted).

2. $C_L = 100\text{pF}$ (see [Figure 13 on page 22](#)).

3. $C_L = 5\text{pF}$ (see [Figure 13 on page 22](#)).

Table 4. Write mode AC characteristics

Symbol	Parameter ⁽¹⁾	M48T59/Y/V		Unit
		-70		
		Min	Max	
t_{AVAV}	WRITE cycle time	70		ns
t_{AVWL}	Address valid to WRITE enable low	0		ns
t_{AVEL}	Address valid to chip enable low	0		ns
t_{WLWH}	WRITE enable pulse width	50		ns
t_{ELEH}	Chip enable low to chip enable high	55		ns
t_{WHAX}	WRITE enable high to address transition	0		ns
t_{EHAX}	Chip enable high to address transition	0		ns
t_{DVWH}	Input valid to WRITE enable high	30		ns
t_{DVEH}	Input valid to chip enable high	30		ns
t_{WHDX}	WRITE enable high to input transition	5		ns
t_{EHDX}	Chip enable high to input transition	5		ns
$t_{WLQZ}^{(2)(3)}$	WRITE enable low to output Hi-Z		25	ns
t_{AVWH}	Address valid to WRITE enable high	60		ns
t_{AVEH}	Address valid to chip enable high	60		ns
$t_{WHQX}^{(2)(3)}$	WRITE enable high to output transition	5		ns

- Valid for ambient operating temperature: $T_A = 0$ to 70°C ; $V_{CC} = 4.5$ to 5.5 V, 4.75 to 5.5 V, or 3.0 to 3.6 V (except where noted).
- $C_L = 5\text{pF}$ (see [Figure 13 on page 22](#)).
- If \bar{E} goes low simultaneously with \bar{W} going low, the outputs remain in the high impedance state.

2.3 Data retention mode

With valid V_{CC} applied, the M48T59/Y/V operates as a conventional BYTEWIDE™ static RAM. Should the supply voltage decay, the RAM will automatically power-fail deselect, write protecting itself when V_{CC} falls within the $V_{PFD}(\text{max})$, $V_{PFD}(\text{min})$ window. All outputs become high impedance, and all inputs are treated as “don't care.”

Note: A power failure during a WRITE cycle may corrupt data at the currently addressed location, but does not jeopardize the rest of the RAM's content. At voltages below $V_{PFD}(\text{min})$, the user can be assured the memory will be in a write protected state, provided the V_{CC} fall time is not less than t_F . The M48T59/Y/V may respond to transient noise spikes on V_{CC} that reach into the deselect window during the time the device is sampling V_{CC} . Therefore, decoupling of the power supply lines is recommended.

When V_{CC} drops below V_{SO} , the control circuit switches power to the internal battery which preserves data and powers the clock. The internal button cell will maintain data in the M48T59/Y/V for an accumulated period of at least 7 years when V_{CC} is less than V_{SO} . As system power returns and V_{CC} rises above V_{SO} , the battery is disconnected and the power supply is switched to external V_{CC} . Deselect continues for t_{rec} after V_{CC} reaches $V_{PFD}(\text{max})$.

For more information on Battery Storage Life refer to the Application Note AN1012.

3 Clock operations

3.1 Reading the clock

Updates to the TIMEKEEPER[®] registers should be halted before clock data is read to prevent reading data in transition. The BiPORT[™] TIMEKEEPER cells in the RAM array are only data registers and not the actual clock counters, so updating the registers can be halted without disturbing the clock itself.

Updating is halted when a '1' is written to the READ Bit, D6 in the Control register (1FF8h). As long as a '1' remains in that position, updating is halted. After a halt is issued, the registers reflect the count; that is, the day, date, and the time that were current at the moment the halt command was issued.

All of the TIMEKEEPER registers are updated simultaneously. A halt will not interrupt an update in progress. Updating is within a second after the bit is reset to a '0.'

3.2 Setting the clock

Bit D7 of the Control register (1FF8h) is the WRITE Bit. Setting the WRITE Bit to a '1,' like the READ Bit, halts updates to the TIMEKEEPER registers. The user can then load them with the correct day, date, and time data in 24 hour BCD format (see [Table 5 on page 13](#)). Resetting the WRITE Bit to a '0' then transfers the values of all time registers (1FF9h-1FFFh) to the actual TIMEKEEPER counters and allows normal operation to resume. After the WRITE Bit is reset, the next clock update will occur within approximately one second.

See the Application Note AN923, "TIMEKEEPER Rolling Into the 21st Century" for information on Century Rollover.

Note: Upon power-up following a power failure, both the WRITE Bit and the READ Bit will be reset to '0.'

3.3 Stopping and starting the oscillator

The oscillator may be stopped at any time. If the device is going to spend a significant amount of time on the shelf, the oscillator can be turned off to minimize current drain on the battery. The STOP Bit is the MSB of the seconds register. Setting it to a '1' stops the oscillator. The M48T59/Y/V in the DIP package is shipped from STMicroelectronics with the STOP Bit set to a '1.' When reset to a '0,' the M48T59/Y/V oscillator starts within one second.

Note: It is not necessary to set the WRITE Bit when setting or resetting the FREQUENCY TEST Bit (FT), the STOP Bit (ST) or the CENTURY ENABLE Bit (CEB).

Table 5. Register map

Address	Data								Function/range BCD format	
	D7	D6	D5	D4	D3	D2	D1	D0		
1FFFh	10 Years				Year				Year	00-99
1FFEh	0	0	0	10 M	Month				Month	01-12
1FFDh	0	0	10 date		Date				Date	01-31
1FFCh	0	FT	CEB	CB	0	Day			Century/day	00-01/01-07
1FFBh	0	0	10 hours		Hours				Hours	00-23
1FFAh	0	10 minutes			Minutes				Minutes	00-59
1FF9h	ST	10 seconds			Seconds				Seconds	00-59
1FF8h	W	R	S	Calibration				Control		
1FF7h	WDS	BMB 4	BMB 3	BMB 2	BMB 1	BMB 0	RB1	RB0	Watchdog	
1FF6h	AFE	Y	ABE	Y	Y	Y	Y	Y	Interrupts	
1FF5h	RPT4	Y	Al. 10 date		Alarm date				Alarm date	01-31
1FF4h	RPT3	Y	Al. 10 hours		Alarm hours				Alarm hours	00-23
1FF3h	RPT2	Alarm 10 minutes			Alarm minutes				Alarm minutes	00-59
1FF2h	RPT1	Alarm 10 seconds			Alarm seconds				Alarm seconds	00-59
1FF1h	Y	Y	Y	Y	Y	Y	Y	Y	Unused	
1FF0h	WDF	AF	Z	BL	Z	Z	Z	Z	Flags	

Keys:

- S = Sign bit
- FT = Frequency test bit
- R = Read bit
- W = Write bit
- ST = Stop bit
- 0 = Must be set to '0'
- Y = '1' or '0'
- Z = '0' and are read only
- AF = Alarm flag (read only)
- BL = Battery low (read only)
- WDS = Watchdog steering bit
- BMB0-BMB4 = Watchdog multiplier bits
- RB0-RB1 = Watchdog resolution bits
- AFE = Alarm flag enable
- ABE = Alarm in battery back-up mode enable
- RPT1-RPT4 = Alarm repeat mode bits
- WDF = Watchdog flag (read only)
- CEB = Century enable bit
- CB = Century bit

3.4 Calibrating the clock

The M48T59/Y/V is driven by a quartz-controlled oscillator with a nominal frequency of 32,768 Hz. The devices are tested not to exceed 35 PPM (parts per million) oscillator frequency error at 25°C, which equates to about ± 1.53 minutes per month. With the calibration bits properly set, the accuracy of each M48T59/Y/V improves to better than $+1/-2$ PPM at 25°C.

The oscillation rate of any crystal changes with temperature (see [Figure 8 on page 15](#)). Most clock chips compensate for crystal frequency and temperature shift error with cumbersome “trim” capacitors. The M48T59/Y/V design, however, employs periodic counter correction. The calibration circuit adds or subtracts counts from the oscillator divider circuit at the divide by 256 stage, as shown in [Figure 9 on page 15](#). The number of times pulses are blanked (subtracted, negative calibration) or split (added, positive calibration) depends upon the value loaded into the five-bit Calibration byte found in the Control Register. Adding counts speeds the clock up, subtracting counts slows the clock down.

The Calibration Byte occupies the five lower order bits (D4-D0) in the Control register (1FF8h). These bits can be set to represent any value between 0 and 31 in binary form. Bit D5 is the Sign Bit; '1' indicates positive calibration, '0' indicates negative calibration. Calibration occurs within a 64 minute cycle. The first 62 minutes in the cycle may, once per minute, have one second either shortened by 128 or lengthened by 256 oscillator cycles. If a binary '1' is loaded into the register, only the first 2 minutes in the 64 minute cycle will be modified; if a binary 6 is loaded, the first 12 will be affected, and so on.

Therefore, each calibration step has the effect of adding 512 or subtracting 256 oscillator cycles; for every 125,829,120 actual oscillator cycles, that is +4.068 or -2.034 PPM of adjustment per calibration step in the calibration register. Assuming that the oscillator is in fact running at exactly 32,768 Hz, each of the 31 increments in the Calibration Byte would represent +10.7 or -5.35 seconds per month which corresponds to a total range of +5.5 or -2.75 minutes per month.

Two methods are available for ascertaining how much calibration a given M48T59/Y/V may require. The first involves simply setting the clock, letting it run for a month and comparing it to a known accurate reference (like WWV broadcasts). While that may seem crude, it allows the designer to give the end user the ability to calibrate his clock as his environment may require, even after the final product is packaged in a non-user serviceable enclosure. All the designer has to do is provide a simple utility that accesses the Calibration Byte.

The second approach is better suited to a manufacturing environment, and involves the use of the $\overline{\text{IRQ}}/\text{FT}$ pin. The pin will toggle at 512 Hz when the Stop Bit (D7 of 1FF9h) is '0,' the FT Bit (D6 of 1FFCh) is '1,' the AFE Bit (D7 of 1FF6h) is '0,' and the Watchdog Steering Bit (D7 of 1FF7h) is '1' or the Watchdog Register is reset (1FF7h = 0).

Any deviation from 512 Hz indicates the degree and direction of oscillator frequency shift at the test temperature. For example, a reading of 512.01024 Hz would indicate a +20 PPM oscillator frequency error, requiring a -10 (WR001010) to be loaded into the Calibration Byte for correction. Note that setting or changing the Calibration Byte does not affect the Frequency Test output frequency.

The $\overline{\text{IRQ}}/\text{FT}$ pin is an open drain output which requires a pull-up resistor for proper operation. A 500 - 10 k Ω resistor is recommended in order to control the rise time. The FT Bit is cleared on power-down.

For more information on calibration, see Application Note AN934, “TIMEKEEPER Calibration.”

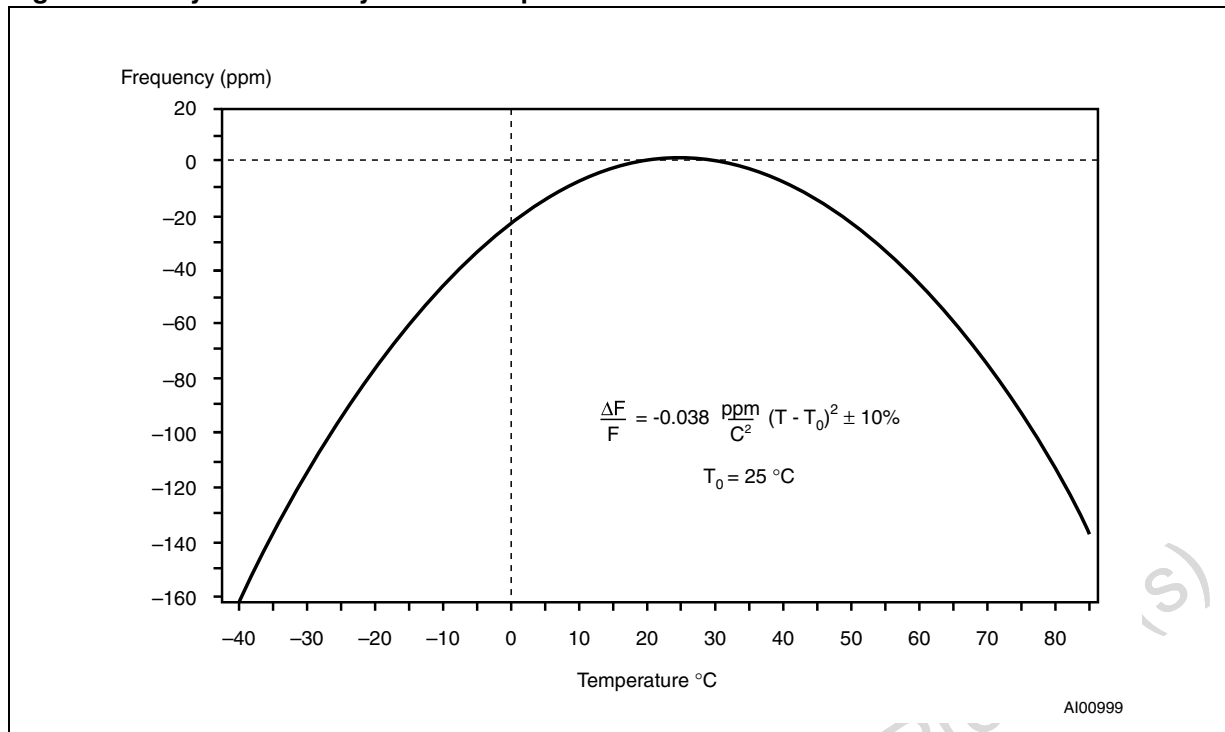
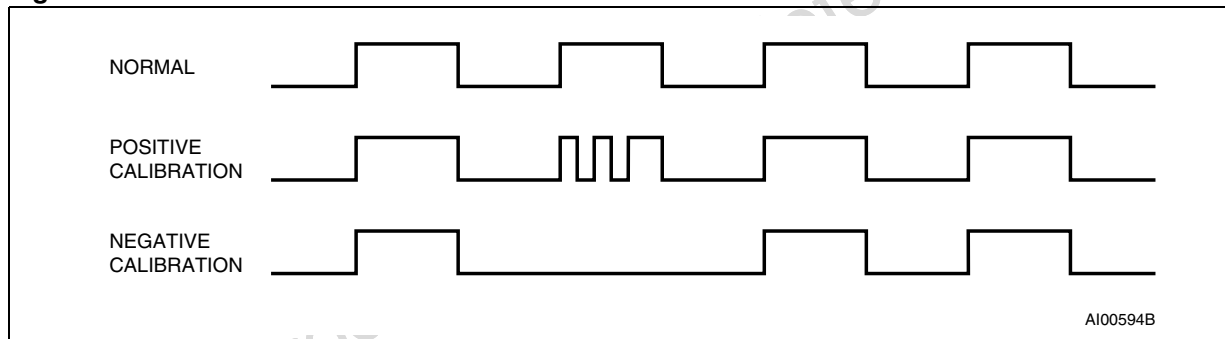
Figure 8. Crystal accuracy across temperature**Figure 9. Clock calibration**

3.5 Setting the alarm clock

Registers 1FF5h-1FF2h contain the alarm settings. The alarm can be configured to go off at a prescribed time on a specific day of the month or repeat every month, day, hour, minute, or second. It can also be programmed to go off while the M48T59/Y/V is in the battery back-up mode of operation to serve as a system wake-up call.

Bits RPT1-RPT4 put the alarm in the repeat mode of operation. [Table 6 on page 16](#) shows the possible configurations. Codes not listed in the table default to the once per second mode to quickly alert the user of an incorrect alarm setting.

Note: User must transition address (or toggle chip enable) to see Flag Bit change.

When the clock information matches the alarm clock settings based on the match criteria defined by RPT1-RPT4, AF (Alarm Flag) is set. If AFE (Alarm Flag Enable) is also set, the

alarm condition activates the $\overline{\text{IRQ/FT}}$ pin. To disable the alarm, write '0' to the Alarm Date Register and RPT1-4. The Alarm Flag and the $\overline{\text{IRQ/FT}}$ output are cleared by a READ to the Flags Register as shown in *Figure 10 on page 16*. A subsequent READ of the Flags Register is necessary to see that the value of the Alarm Flag has been reset to '0.'

The $\overline{\text{IRQ/FT}}$ pin can also be activated in the battery back-up mode. The $\overline{\text{IRQ/FT}}$ will go low if an alarm occurs and both the ABE (Alarm in Battery Back-up Mode Enable) and the AFE are set. The ABE and AFE bits are reset during power-up, therefore an alarm generated during power-up will only set AF. The user can read the Flag Register at system boot-up to determine if an alarm was generated while the M48T59/Y/V was in the deselect mode during power-down. *Figure 11 on page 17* illustrates the back-up mode alarm timing.

Figure 10. Alarm interrupt reset waveform

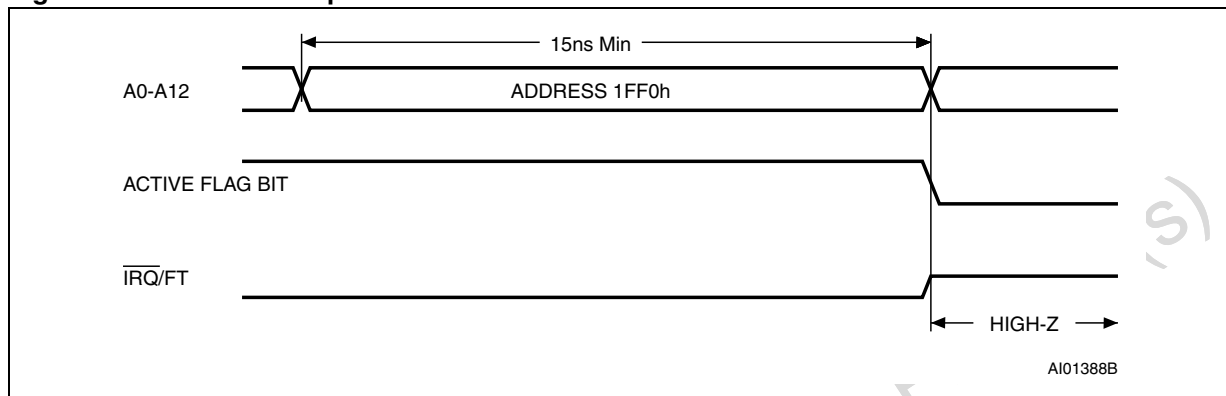
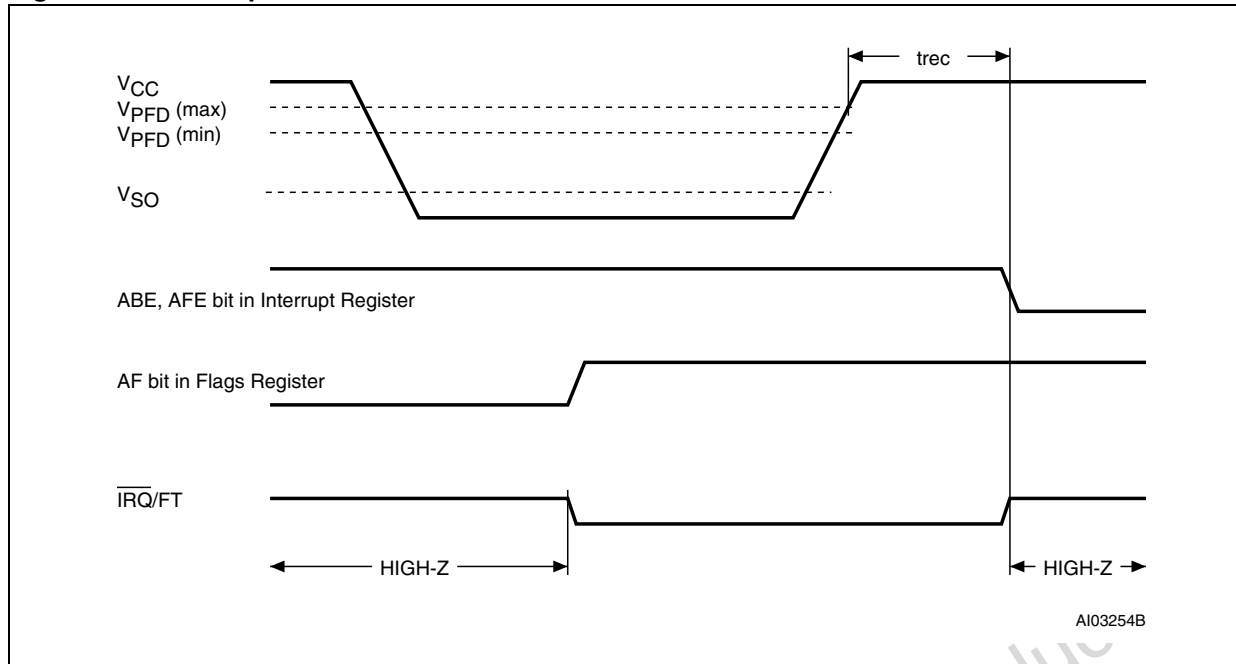

Table 6. Alarm repeat mode

RPT4	RPT3	RPT2	RPT1	Alarm activated
1	1	1	1	Once per second
1	1	1	0	Once per minute
1	1	0	0	Once per hour
1	0	0	0	Once per day
0	0	0	0	Once per month

Figure 11. Back-up mode alarm waveforms



3.6 Watchdog timer

The watchdog timer can be used to detect an out-of-control microprocessor. The user programs the watchdog timer by setting the desired amount of time-out into the eight-bit Watchdog Register (Address 1FF7h). The five bits (BMB4-BMB0) that store a binary multiplier and the two lower order bits (RB1-RB0) select the resolution, where 00 = 1/16 second, 01 = 1/4 second, 10 = 1 second, and 11 = 4 seconds. The amount of time-out is then determined to be the multiplication of the five-bit multiplier value with the resolution. (For example: writing 00001110 in the Watchdog Register = 3 x 1 or 3 seconds).

Note: Accuracy of timer is within \pm the selected resolution.

If the processor does not reset the timer within the specified period, the M48T59/Y/V sets the WDF (Watchdog Flag) and generates a watchdog interrupt or a microprocessor reset. WDF is reset by reading the Flags Register (Address 1FF0h).

Note: User must transition address (or toggle chip enable) to see Flag Bit change.

The most significant bit of the Watchdog Register is the Watchdog Steering Bit. When set to a '0,' the watchdog will activate the $\overline{\text{IRQ/FT}}$ pin when timed-out. When WDS is set to a '1,' the watchdog will output a negative pulse on the $\overline{\text{RST}}$ pin for a duration of t_{rec} . The Watchdog Register, the FT Bit, and the AFE and ABE Bits will reset to a '0' at the end of a watchdog time-out when the WDS bit is set to a '1.'

The watchdog timer resets when the microprocessor performs a re-write of the Watchdog Register. The time-out period then starts over. The watchdog timer is disabled by writing a value of 00000000 to the eight bits in the Watchdog Register.

The watchdog function is automatically disabled upon power-down and the Watchdog Register is cleared. If the watchdog function is set to output to the $\overline{\text{IRQ/FT}}$ pin and the frequency test function is activated, the watchdog or alarm function prevails and the frequency test function is denied.

3.7 Power-on reset

The M48T59/Y/V continuously monitors V_{CC} . When V_{CC} falls to the power fail detect trip point, the \overline{RST} pulls low (open drain) and remains low on power-up for t_{rec} after V_{CC} passes V_{PFD} (max). \overline{RST} is valid for all V_{CC} conditions. The \overline{RST} pin is an open drain output and an appropriate resistor to V_{CC} should be chosen to control rise time.

3.8 Programmable interrupts

The M48T59/Y/V provides two programmable interrupts; an alarm and a watchdog. When an interrupt condition occurs, the M48T59/Y/V sets the appropriate flag bit in the Flag Register 1FF0h. The interrupt enable bits in (AFE and ABE) in 1FF6h and the Watchdog Steering (WDS) Bit in 1FF7h allow the interrupt to activate the \overline{IRQ}/FT pin.

The Alarm flag and the \overline{IRQ}/FT output are cleared by a READ to the Flags Register. An interrupt condition reset will not occur unless the addresses are stable at the flag location for at least 15ns while the device is in the READ Mode as shown in [Figure 10 on page 16](#).

The \overline{IRQ}/FT pin is an open drain output and requires a pull-up resistor (10 k Ω recommended) to V_{CC} . The pin remains in the high impedance state unless an interrupt occurs or the Frequency Test Mode is enabled.

3.9 Battery low flag

The M48T59/Y/V automatically performs periodic battery voltage monitoring upon power-up and at factory-programmed time intervals of 24 hours (at day rollover) as long as the device is powered and the oscillator is running. The Battery Low Flag (BL), Bit D4 of the Flags Register 1FF0h, will be asserted high if the internal or SNAPHAT[®] battery is found to be less than approximately 2.5 V. The BL Flag will remain active until completion of battery replacement and subsequent battery low monitoring tests, either during the next power-up sequence or the next scheduled 24-hour interval.

If a battery low is generated during a power-up sequence, this indicates that the battery voltage is below 2.5 V (approximately), which may be insufficient to maintain data integrity. Data should be considered suspect and verified as correct. A fresh battery should be installed.

If a battery low indication is generated during the 24-hour interval check, this indicates the battery is near end of life. However, data has not been compromised due to the fact that a nominal V_{CC} is supplied. In order to insure data integrity during subsequent periods of battery back-up mode, it is recommended that the battery be replaced. The SNAPHAT top may be replaced while V_{CC} is applied to the device.

Note: This will cause the clock to lose time during the interval the battery/crystal is removed.

Note: Battery monitoring is a useful technique only when performed periodically. The M48T59/Y/V only monitors the battery when a nominal V_{CC} is applied to the device. Thus applications which require extensive durations in the battery back-up mode should be powered-up periodically (at least once every few months) in order for this technique to be beneficial. Additionally, if a battery low is indicated, data integrity should be verified upon power-up via a checksum or other technique.

3.10 Century bit

Bit D5 and D4 of Clock Register 1FFCh contain the CENTURY ENABLE Bit (CEB) and the CENTURY Bit (CB). Setting CEB to a '1' will cause CB to toggle, either from a '0' to '1' or from '1' to '0' at the turn of the century (depending upon its initial state). If CEB is set to a '0,' CB will not toggle.

Note: The WRITE Bit must be set in order to write to the CENTURY Bit.

3.11 Initial power-on defaults

Upon application of power to the device, the following register bits are set to a '0' state: WDS; BMB0-BMB4; RB0-RB1; AFE; ABE; W; R; FT (see [Table 7](#)).

Table 7. Default values

Condition	W	R	FT	AFE	ABE	Watchdog register ⁽¹⁾
Initial power-up (Battery attach for SNAPHAT) ⁽²⁾	0	0	0	0	0	0
Subsequent power-up / RESET ⁽³⁾	0	0	0	0	0	0
Power-down ⁽⁴⁾	0	0	0	1	1	0

1. WDS, BMB0-BMB4, RBO, RB1.
2. State of other control bits undefined.
3. State of other control bits remains unchanged.
4. Assuming these bits set to '1' prior to power-down.

3.12 V_{CC} noise and negative going transients

I_{CC} transients, including those produced by output switching, can produce voltage fluctuations, resulting in spikes on the V_{CC} bus. These transients can be reduced if capacitors are used to store energy which stabilizes the V_{CC} bus. The energy stored in the bypass capacitors will be released as low going spikes are generated or energy will be absorbed when overshoots occur. A ceramic bypass capacitor value of 0.1 μF (as shown in [Figure 12 on page 20](#)) is recommended in order to provide the needed filtering.

In addition to transients that are caused by normal SRAM operation, power cycling can generate negative voltage spikes on V_{CC} that drive it to values below V_{SS} by as much as one volt. These negative spikes can cause data corruption in the SRAM while in battery backup mode. To protect from these voltage spikes, it is recommended to connect a schottky diode from V_{CC} to V_{SS} (cathode connected to V_{CC}, anode to V_{SS}). Schottky diode 1N5817 is recommended for through hole and MBRS120T3 is recommended for surface mount.

Figure 12. Supply voltage protection

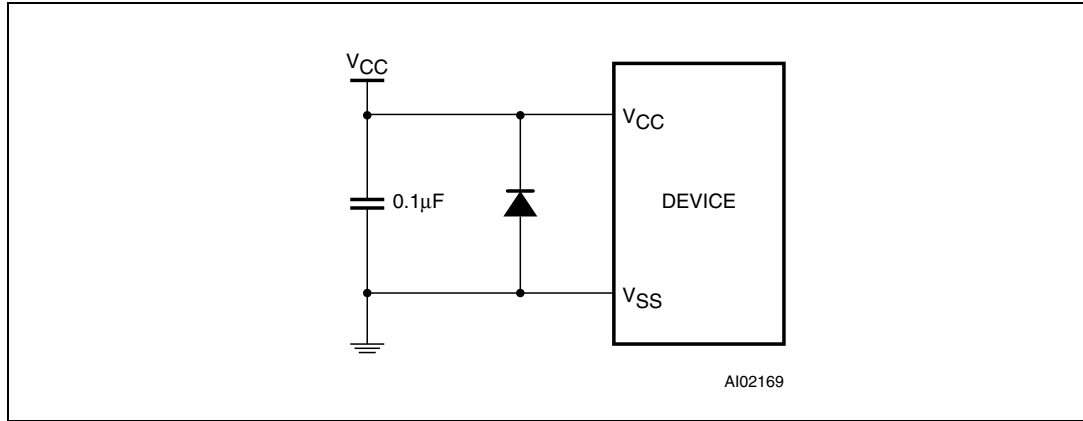

Obsolete Product(s) - Obsolete Product(s)

4 Maximum ratings

Stressing the device above the rating listed in the “Absolute Maximum Ratings” table may cause permanent damage to the device. These are stress ratings only and operation of the device at these or any other conditions above those indicated in the Operating sections of this specification is not implied. Exposure to Absolute Maximum Rating conditions for extended periods may affect device reliability. Refer also to the STMicroelectronics SURE Program and other relevant quality documents.

Table 8. Absolute maximum ratings

Symbol	Parameter	Value	Unit
T_A	Ambient operating temperature	0 to 70	°C
T_{STG}	Storage temperature (V_{CC} off, oscillator off)	-40 to 85	°C
$T_{SLD}^{(1)(2)(3)}$	Lead solder temperature for 10 seconds	260	°C
V_{IO}	Input or output voltages	-0.3 to 7	V
V_{CC}	Supply voltage	M48T59/M48T59Y	-0.3 to 7
		M48T59V	-0.3 to 4.6
I_O	Output current	20	mA
P_D	Power dissipation	1	W

1. For DIP package: Soldering temperature not to exceed 260°C for 10 seconds (total thermal budget not to exceed 150°C for longer than 30 seconds).
2. For SO package, standard (SnPb) lead finish: Reflow at peak temperature of 225°C (total thermal budget not to exceed 180°C for between 90 to 150 seconds).
3. For SO package, Lead-free (Pb-free) lead finish: Reflow at peak temperature of 260°C (total thermal budget not to exceed 245°C for greater than 30 seconds).

Caution: *Negative undershoots below -0.3 V are not allowed on any pin while in the Battery Back-up mode.*

Caution: *Do NOT wave solder SOIC to avoid damaging SNAPHAT sockets.*

5 DC and AC parameters

This section summarizes the operating and measurement conditions, as well as the DC and AC characteristics of the device. The parameters in the following DC and AC Characteristic tables are derived from tests performed under the Measurement Conditions listed in [Table 9](#). Designers should check that the operating conditions in their projects match the measurement conditions when using the quoted parameters.

Table 9. Operating and AC measurement conditions

Parameter	M48T59	M48T59Y	M48T59V	Unit
Supply voltage (V_{CC})	4.75 to 5.5	4.5 to 5.5	3.0 to 3.6	V
Ambient operating temperature (T_A)	0 to 70	0 to 70	0 to 70	°C
Load capacitance (C_L)	100	100	50	pF
Input rise and fall times	≤ 5	≤ 5	≤ 5	ns
Input pulse voltages	0 to 3	0 to 3	0 to 3	V
Input and output timing ref. voltages	1.5	1.5	1.5	V

Note: Output Hi-Z is defined as the point where data is no longer driven.

Figure 13. AC measurement load circuit

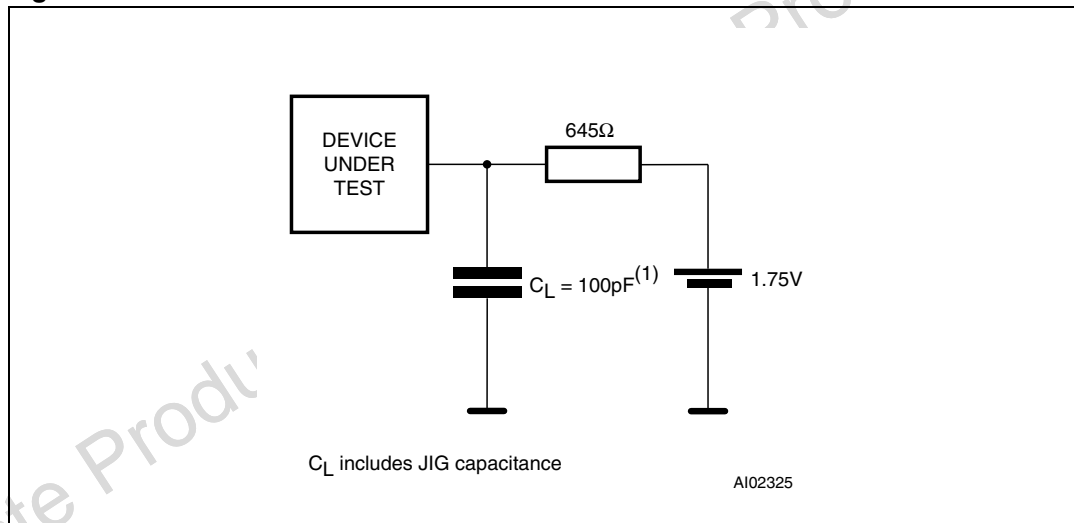

1. 50pF for M48T59V.

Note: Excluding open-drain output pins

Table 10. Capacitance

Symbol	Parameters ⁽¹⁾⁽²⁾	Min	Max	Unit
C_{IN}	Input capacitance		10	pF
$C_{IO}^{(3)}$	Input / output capacitance		10	pF

1. Effective capacitance measured with power supply at 5 V; sampled only, not 100% tested.
2. At 25°C, $f = 1 \text{ MHz}$.
3. Outputs deselected.

Table 11. DC characteristics

Symbol	Parameter	Test condition ⁽¹⁾	M48T59/Y		M48T59V		Unit
			Min	Max	Min	Max	
I_{LI}	Input leakage current	$0V \leq V_{IN} \leq V_{CC}$		± 1		± 1	μA
$I_{LO}^{(2)}$	Output leakage current	$0V \leq V_{OUT} \leq V_{CC}$		± 1		± 1	μA
I_{CC}	Supply current	Outputs open		50		30	mA
I_{CC1}	Supply current (standby) TTL	$\bar{E} = V_{IH}$		3		2	mA
I_{CC2}	Supply current (standby) CMOS	$\bar{E} = V_{CC} - 0.2 V$		3		1	mA
V_{IL}	Input low voltage		-0.3	0.8	-0.3	0.8	V
V_{IH}	Input high voltage		2.2	$V_{CC} + 0.3$	2	$V_{CC} + 0.3$	V
V_{OL}	Output low voltage	$I_{OL} = 2.1 mA$		0.4		0.4	V
	Output low voltage ($\overline{IRQ/FT}$ and \overline{RST}) ⁽³⁾	$I_{OL} = 10 mA$		0.4		0.4	V
V_{OH}	Output high voltage	$I_{OH} = -1 mA$	2.4		2.4		V

- Valid for ambient operating temperature: $T_A = 0$ to $70^\circ C$; $V_{CC} = 4.5$ to $5.5 V$, 4.75 to $5.5 V$, or 3.0 to $3.6 V$ (except where noted).
- Outputs deselected.
- The $\overline{IRQ/FT}$ and \overline{RST} pins are open drain.

Figure 14. Power down/up mode AC waveforms

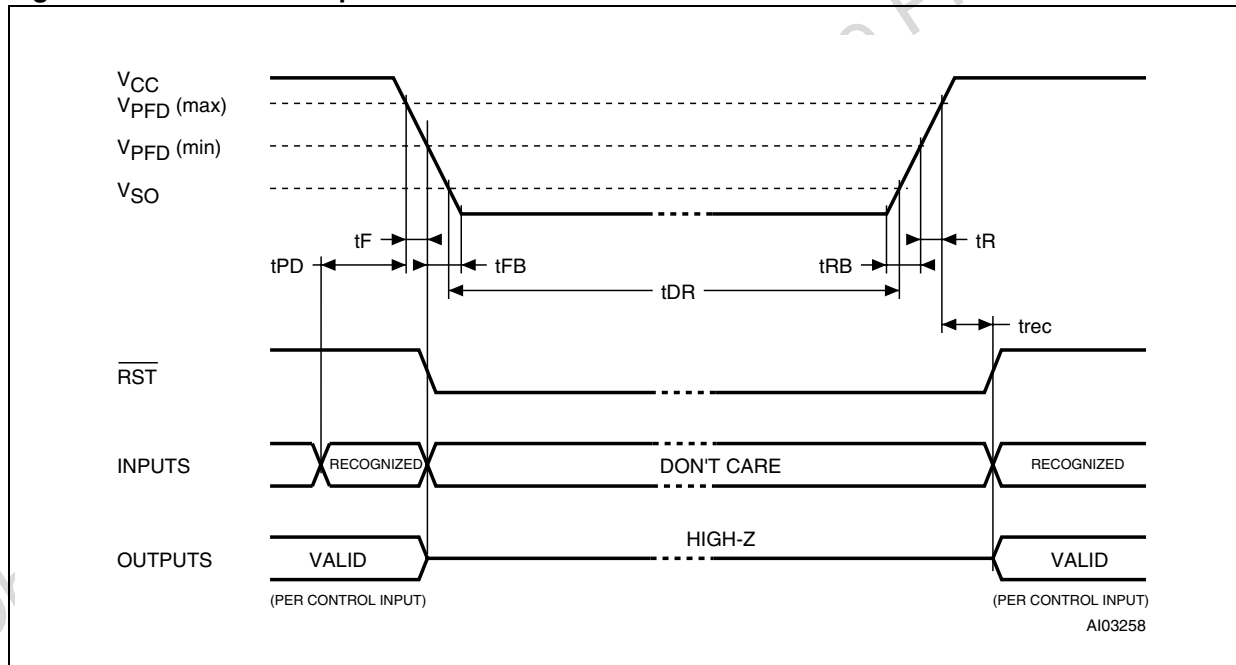

Table 12. Power down/up AC characteristics

Symbol	Parameter ⁽¹⁾	Min	Max	Unit
t_{PD}	\overline{E} or \overline{W} at V_{IH} before power down	0		μs
$t_F^{(2)}$	V_{PFD} (max) to V_{PFD} (min) V_{CC} fall time	300		μs
$t_{FB}^{(3)}$	V_{PFD} (min) to V_{SS} V_{CC} fall time	10		μs
t_R	V_{PFD} (min) to V_{PFD} (max) V_{CC} rise time	10		μs
t_{RB}	V_{SS} to V_{PFD} (min) V_{CC} rise time	1		μs
t_{rec}	V_{PFD} (max) to \overline{RST} high	40	200	ms

- Valid for ambient operating temperature: $T_A = 0$ to $70^\circ C$; $V_{CC} = 4.5$ to 5.5 V, 4.75 to 5.5 V, or 3.0 to 3.6 V (except where noted).
- V_{PFD} (max) to V_{PFD} (min) fall time of less than t_F may result in deselection/write protection not occurring until $200\mu s$ after V_{CC} passes V_{PFD} (min).
- V_{PFD} (min) to V_{SS} fall time of less than t_{FB} may cause corruption of RAM data.

Table 13. Power down/up trip points DC characteristics

Symbol	Parameter ⁽¹⁾⁽²⁾		Min	Typ	Max	Unit
V_{PFD}	Power-fail deselect voltage	M48T59	4.5	4.6	4.75	V
		M48T59Y	4.2	4.35	4.5	V
		M48T59V	2.7	2.9	3.0	V
V_{SO}	Battery back-up switchover voltage	M48T59/Y		3.0		V
		M48T59V		$V_{PFD} - 100mV$		V
$t_{DR}^{(3)}$	Expected data retention time		7			YEARS

- Valid for ambient operating temperature: $T_A = 0$ to $70^\circ C$; $V_{CC} = 4.5$ to 5.5 V, 4.75 to 5.5 V, or 3.0 to 3.6 V (except where noted).
- All voltages referenced to V_{SS} .
- At $25^\circ C$, $V_{CC} = 0$ V.

6 Package mechanical data

In order to meet environmental requirements, ST offers these devices in ECOPACK[®] packages. These packages have a Lead-free second level interconnect. The category of second Level Interconnect is marked on the package and on the inner box label, in compliance with JEDEC Standard JESD97. The maximum ratings related to soldering conditions are also marked on the inner box label. ECOPACK is an ST trademark. ECOPACK specifications are available at: www.st.com.

Figure 15. PCDIP28 – 28-pin plastic DIP, battery CAPHAT, package outline

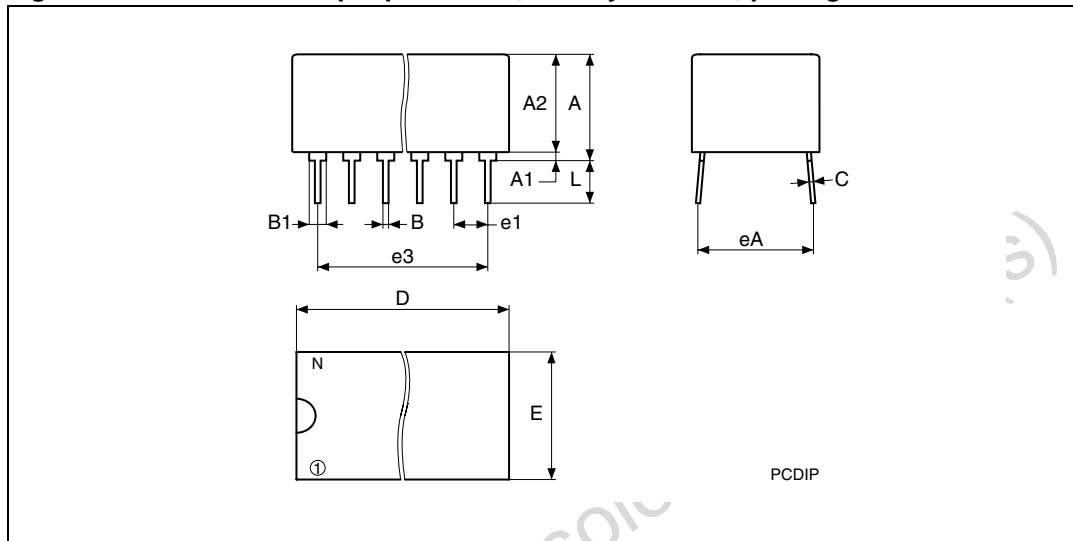

Note: Drawing is not to scale.

Table 14. PCDIP28 – 28-pin plastic DIP, battery CAPHAT, package mechanical data

Symb	mm			inches		
	Typ	Min	Max	Typ	Min	Max
A		8.89	9.65		0.350	0.380
A1		0.38	0.76		0.015	0.030
A2		8.38	8.89		0.330	0.350
B		0.38	0.53		0.015	0.021
B1		1.14	1.78		0.045	0.070
C		0.20	0.31		0.008	0.012
D		39.37	39.88		1.550	1.570
E		17.83	18.34		0.702	0.722
e1		2.29	2.79		0.090	0.110
e3		29.72	36.32		1.170	1.430
eA		15.24	16.00		0.600	0.630
L		3.05	3.81		0.120	0.150
N		28			28	

Figure 16. SOH28 – 28-lead plastic small outline, battery SNAPHAT, package outline

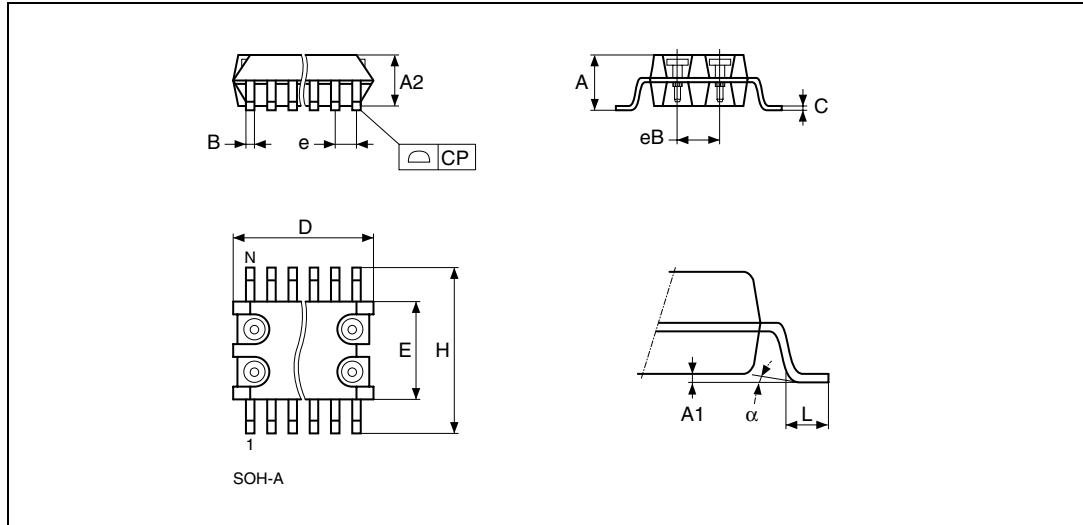

Note: Drawing is not to scale.

Table 15. SOH28 – 28-lead plastic small outline, battery SNAPHAT, pack. mech. data

Symb	mm			inches		
	Typ	Min	Max	Typ	Min	Max
A			3.05			0.120
A1		0.05	0.36		0.002	0.014
A2		2.34	2.69		0.092	0.106
B		0.36	0.51		0.014	0.020
C		0.15	0.32		0.006	0.012
D		17.71	18.49		0.697	0.728
E		8.23	8.89		0.324	0.350
e	1.27	–	–	0.050	–	–
eB		3.20	3.61		0.126	0.142
H		11.51	12.70		0.453	0.500
L		0.41	1.27		0.016	0.050
a		0°	8°		0°	8°
N	28			28		
CP			0.10			0.004

Figure 17. SH – 4-pin SNAPHAT housing for 48mAh battery & crystal, package outline

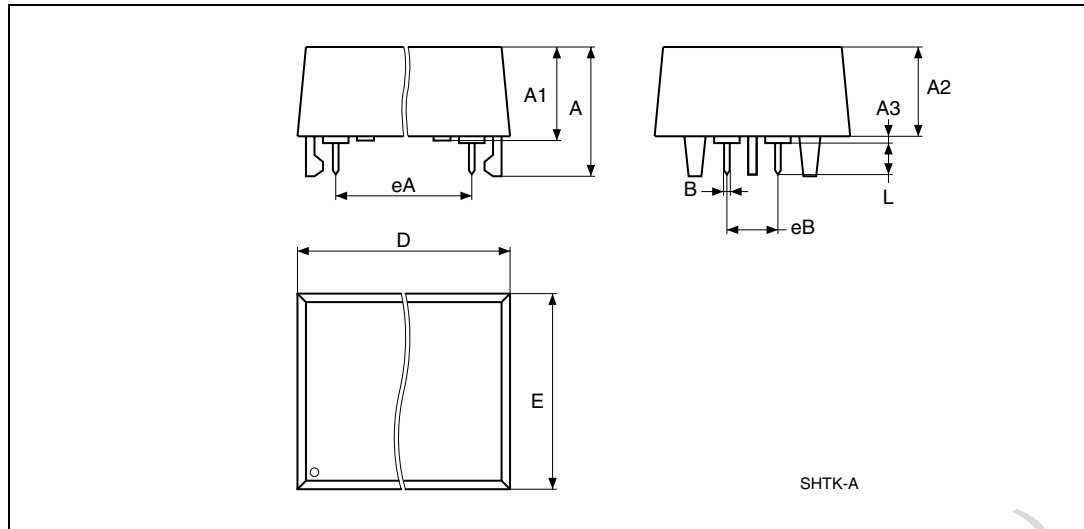

Note: Drawing is not to scale.

Table 16. SH – 4-pin SNAPHAT housing for 48mAh battery & crystal, package mech. data

Symb	mm			inches		
	Typ	Min	Max	Typ	Min	Max
A			9.78			0.385
A1		6.73	7.24		0.265	0.285
A2		6.48	6.99		0.255	0.275
A3			0.38			0.015
B		0.46	0.56		0.018	0.022
D		21.21	21.84		0.835	0.860
E		14.22	14.99		0.560	0.590
eA		15.55	15.95		0.612	0.628
eB		3.20	3.61		0.126	0.142
L		2.03	2.29		0.080	0.090

Figure 18. SH – 4-pin SNAPHAT housing for 120mAh battery & crystal, package outline

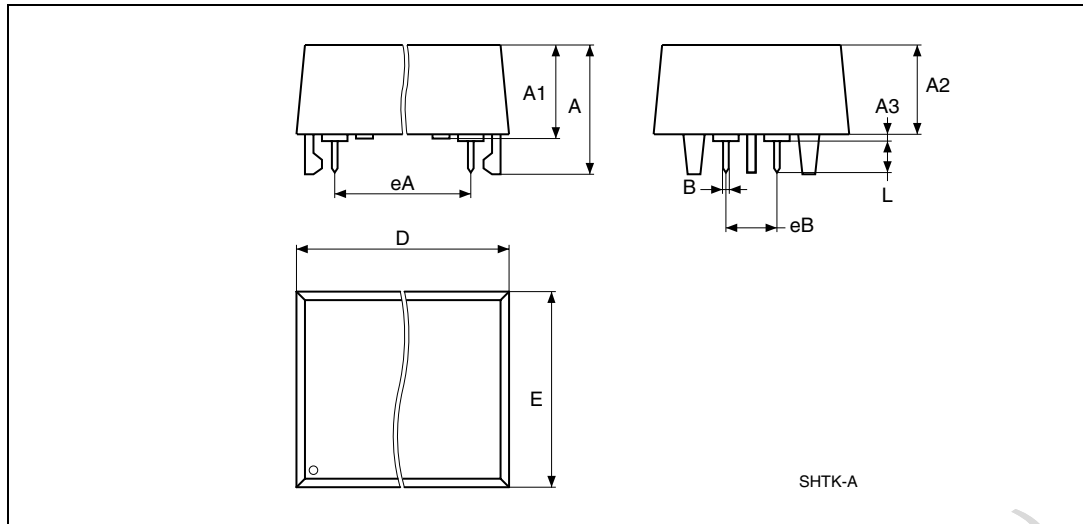

Note: Drawing is not to scale.

Table 17. SH – 4-pin SNAPHAT housing for 120mAh battery & crystal, package mech. data

Symb	mm			inches		
	Typ	Min	Max	Typ	Min	Max
A			10.54			0.415
A1		8.00	8.51		0.315	0.335
A2		7.24	8.00		0.285	0.315
A3			0.38			0.015
B		0.46	0.56		0.018	0.022
D		21.21	21.84		0.835	0.860
E		17.27	18.03		0.680	0.710
eA		15.55	15.95		0.612	0.628
eB		3.20	3.61		0.126	0.142
L		2.03	2.29		0.080	0.090

7 Part numbering

Table 18. Ordering information scheme

Example:	M48T	59Y	-70	MH	1	E
Device type						
M48T						
Supply voltage and write protect voltage						
59 ⁽¹⁾ = $V_{CC} = 4.75$ to 5.5 V; $V_{PFD} = 4.5$ to 4.75 V						
59Y = $V_{CC} = 4.5$ to 5.5 V; $V_{PFD} = 4.2$ to 4.5 V						
59V ⁽²⁾ = $V_{CC} = 3.0$ to 3.6 V; $V_{PFD} = 2.7$ to 3.0 V						
Speed						
-70 = 70 ns						
Package						
PC = PCDIP28						
MH ⁽³⁾ = SOH28						
Temperature range						
1 = 0 to 70°C						
Shipping method						

For SOH28:

E = Lead-free package (ECOPACK[®]), tubes

F = Lead-free package (ECOPACK[®]), tape & reel

For PCDIP28:

blank = tubes

1. The M48T59 part is offered with the PCDIP28 (e.g., CAPHAT[™]) package only.
2. Contact local ST sales office for availability of 3.3 V version.
3. The SOIC package (SOH28) requires the SNAPHAT[®] battery/crystal package which is ordered separately under the part number "M4TXX-BR12SH" in plastic tube or "M4TXX-BR12SHTR" in tape & reel form (see [Table 19](#)).

Caution: Do not place the SNAPHAT battery package "M4TXX-BR12SH" in conductive foam as it will drain the lithium button-cell battery.

For other options, or for more information on any aspect of this device, please contact the ST sales office nearest you.

Table 19. SNAPHAT battery table

Part number	Description	Package
M4T28-BR12SH1	Lithium battery (48mAh) SNAPHAT	SH
M4T32-BR12SHx	Lithium battery (120mAh) SNAPHAT	SH

Obsolete Product(s) - Obsolete Product(s)

8 Revision history

Table 20. Document revision history

Date	Revision	Changes
Oct-1999	1.0	First Issue
22-Mar-2000	1.1	Century Bit Paragraph added; t_{FB} value changed (Table 12)
13-Jul-2000	2.0	From Preliminary Data to Data Sheet
14-May-2001	3.0	Reformatted, Ind. Temp. added (Table 9), SNAPHAT table added (Table 19), temp/voltage info. added to tables (Table 10 , 11 , 3 , 4 , 12 , 13)
31-Jul-2001	3.1	Formatting changes from recent document review findings
06-Aug-2001	3.2	Fix text for Setting the Alarm Clock (Figure 10)
20-May-2002	3.3	Modify reflow time and temperature footnotes (Table 8)
07-Aug-2002	3.4	Add marketing status note (Table 18)
01-Apr-2003	4.0	v2.2 template applied; test condition updated (Table 13)
02-Apr-2004	5.0	Reformatted; update Lead-free package information (Table 8 , 18)
25-Nov-2004	6.0	Remove all Industrial temperature references (Table 3 , 4 , 8 , 9 , 11 , 12 , 13 , 18)
01-Apr-2008	7.0	Product status is "Not for New Design"; reformatted document; added lead-free second level interconnect information to cover page and Section 6: Package mechanical data ; updated Table 11 , 19 .

Please Read Carefully:

Information in this document is provided solely in connection with ST products. STMicroelectronics NV and its subsidiaries ("ST") reserve the right to make changes, corrections, modifications or improvements, to this document, and the products and services described herein at any time, without notice.

All ST products are sold pursuant to ST's terms and conditions of sale.

Purchasers are solely responsible for the choice, selection and use of the ST products and services described herein, and ST assumes no liability whatsoever relating to the choice, selection or use of the ST products and services described herein.

No license, express or implied, by estoppel or otherwise, to any intellectual property rights is granted under this document. If any part of this document refers to any third party products or services it shall not be deemed a license grant by ST for the use of such third party products or services, or any intellectual property contained therein or considered as a warranty covering the use in any manner whatsoever of such third party products or services or any intellectual property contained therein.

UNLESS OTHERWISE SET FORTH IN ST'S TERMS AND CONDITIONS OF SALE ST DISCLAIMS ANY EXPRESS OR IMPLIED WARRANTY WITH RESPECT TO THE USE AND/OR SALE OF ST PRODUCTS INCLUDING WITHOUT LIMITATION IMPLIED WARRANTIES OF MERCHANTABILITY, FITNESS FOR A PARTICULAR PURPOSE (AND THEIR EQUIVALENTS UNDER THE LAWS OF ANY JURISDICTION), OR INFRINGEMENT OF ANY PATENT, COPYRIGHT OR OTHER INTELLECTUAL PROPERTY RIGHT.

UNLESS EXPRESSLY APPROVED IN WRITING BY AN AUTHORIZED ST REPRESENTATIVE, ST PRODUCTS ARE NOT RECOMMENDED, AUTHORIZED OR WARRANTED FOR USE IN MILITARY, AIR CRAFT, SPACE, LIFE SAVING, OR LIFE SUSTAINING APPLICATIONS, NOR IN PRODUCTS OR SYSTEMS WHERE FAILURE OR MALFUNCTION MAY RESULT IN PERSONAL INJURY, DEATH, OR SEVERE PROPERTY OR ENVIRONMENTAL DAMAGE. ST PRODUCTS WHICH ARE NOT SPECIFIED AS "AUTOMOTIVE GRADE" MAY ONLY BE USED IN AUTOMOTIVE APPLICATIONS AT USER'S OWN RISK.

Resale of ST products with provisions different from the statements and/or technical features set forth in this document shall immediately void any warranty granted by ST for the ST product or service described herein and shall not create or extend in any manner whatsoever, any liability of ST.

ST and the ST logo are trademarks or registered trademarks of ST in various countries.

Information in this document supersedes and replaces all information previously supplied.

The ST logo is a registered trademark of STMicroelectronics. All other names are the property of their respective owners.

© 2008 STMicroelectronics - All rights reserved

STMicroelectronics group of companies

Australia - Belgium - Brazil - Canada - China - Czech Republic - Finland - France - Germany - Hong Kong - India - Israel - Italy - Japan - Malaysia - Malta - Morocco - Singapore - Spain - Sweden - Switzerland - United Kingdom - United States of America

www.st.com

Looking for pricing, stock, or lifecycle information?

Click below to explore more details on WIN SOURCE:

 [View M48T59Y-70MH1E on WIN SOURCE](#)

 [STMicroelectronics](#) Information

Optimize Your Supply Chain with WIN SOURCE Solutions

-  Global Sourcing Solution
-  Obsolete Management
-  Cost Control Management
-  Shortage Management
-  Alternative Solution
-  Excess Inventory Management