

To our customers,

Old Company Name in Catalogs and Other Documents

On April 1st, 2010, NEC Electronics Corporation merged with Renesas Technology Corporation, and Renesas Electronics Corporation took over all the business of both companies. Therefore, although the old company name remains in this document, it is a valid Renesas Electronics document. We appreciate your understanding.

Renesas Electronics website: <http://www.renesas.com>

April 1st, 2010
Renesas Electronics Corporation

Issued by: Renesas Electronics Corporation (<http://www.renesas.com>)

Send any inquiries to <http://www.renesas.com/inquiry>.

Notice

1. All information included in this document is current as of the date this document is issued. Such information, however, is subject to change without any prior notice. Before purchasing or using any Renesas Electronics products listed herein, please confirm the latest product information with a Renesas Electronics sales office. Also, please pay regular and careful attention to additional and different information to be disclosed by Renesas Electronics such as that disclosed through our website.
2. Renesas Electronics does not assume any liability for infringement of patents, copyrights, or other intellectual property rights of third parties by or arising from the use of Renesas Electronics products or technical information described in this document. No license, express, implied or otherwise, is granted hereby under any patents, copyrights or other intellectual property rights of Renesas Electronics or others.
3. You should not alter, modify, copy, or otherwise misappropriate any Renesas Electronics product, whether in whole or in part.
4. Descriptions of circuits, software and other related information in this document are provided only to illustrate the operation of semiconductor products and application examples. You are fully responsible for the incorporation of these circuits, software, and information in the design of your equipment. Renesas Electronics assumes no responsibility for any losses incurred by you or third parties arising from the use of these circuits, software, or information.
5. When exporting the products or technology described in this document, you should comply with the applicable export control laws and regulations and follow the procedures required by such laws and regulations. You should not use Renesas Electronics products or the technology described in this document for any purpose relating to military applications or use by the military, including but not limited to the development of weapons of mass destruction. Renesas Electronics products and technology may not be used for or incorporated into any products or systems whose manufacture, use, or sale is prohibited under any applicable domestic or foreign laws or regulations.
6. Renesas Electronics has used reasonable care in preparing the information included in this document, but Renesas Electronics does not warrant that such information is error free. Renesas Electronics assumes no liability whatsoever for any damages incurred by you resulting from errors in or omissions from the information included herein.
7. Renesas Electronics products are classified according to the following three quality grades: “Standard”, “High Quality”, and “Specific”. The recommended applications for each Renesas Electronics product depends on the product’s quality grade, as indicated below. You must check the quality grade of each Renesas Electronics product before using it in a particular application. You may not use any Renesas Electronics product for any application categorized as “Specific” without the prior written consent of Renesas Electronics. Further, you may not use any Renesas Electronics product for any application for which it is not intended without the prior written consent of Renesas Electronics. Renesas Electronics shall not be in any way liable for any damages or losses incurred by you or third parties arising from the use of any Renesas Electronics product for an application categorized as “Specific” or for which the product is not intended where you have failed to obtain the prior written consent of Renesas Electronics. The quality grade of each Renesas Electronics product is “Standard” unless otherwise expressly specified in a Renesas Electronics data sheets or data books, etc.
 - “Standard”: Computers; office equipment; communications equipment; test and measurement equipment; audio and visual equipment; home electronic appliances; machine tools; personal electronic equipment; and industrial robots.
 - “High Quality”: Transportation equipment (automobiles, trains, ships, etc.); traffic control systems; anti-disaster systems; anti-crime systems; safety equipment; and medical equipment not specifically designed for life support.
 - “Specific”: Aircraft; aerospace equipment; submersible repeaters; nuclear reactor control systems; medical equipment or systems for life support (e.g. artificial life support devices or systems), surgical implantations, or healthcare intervention (e.g. excision, etc.), and any other applications or purposes that pose a direct threat to human life.
8. You should use the Renesas Electronics products described in this document within the range specified by Renesas Electronics, especially with respect to the maximum rating, operating supply voltage range, movement power voltage range, heat radiation characteristics, installation and other product characteristics. Renesas Electronics shall have no liability for malfunctions or damages arising out of the use of Renesas Electronics products beyond such specified ranges.
9. Although Renesas Electronics endeavors to improve the quality and reliability of its products, semiconductor products have specific characteristics such as the occurrence of failure at a certain rate and malfunctions under certain use conditions. Further, Renesas Electronics products are not subject to radiation resistance design. Please be sure to implement safety measures to guard them against the possibility of physical injury, and injury or damage caused by fire in the event of the failure of a Renesas Electronics product, such as safety design for hardware and software including but not limited to redundancy, fire control and malfunction prevention, appropriate treatment for aging degradation or any other appropriate measures. Because the evaluation of microcomputer software alone is very difficult, please evaluate the safety of the final products or system manufactured by you.
10. Please contact a Renesas Electronics sales office for details as to environmental matters such as the environmental compatibility of each Renesas Electronics product. Please use Renesas Electronics products in compliance with all applicable laws and regulations that regulate the inclusion or use of controlled substances, including without limitation, the EU RoHS Directive. Renesas Electronics assumes no liability for damages or losses occurring as a result of your noncompliance with applicable laws and regulations.
11. This document may not be reproduced or duplicated, in any form, in whole or in part, without prior written consent of Renesas Electronics.
12. Please contact a Renesas Electronics sales office if you have any questions regarding the information contained in this document or Renesas Electronics products, or if you have any other inquiries.

(Note 1) “Renesas Electronics” as used in this document means Renesas Electronics Corporation and also includes its majority-owned subsidiaries.

(Note 2) “Renesas Electronics product(s)” means any product developed or manufactured by or for Renesas Electronics.

DESCRIPTION

The 3823 group is the 8-bit microcomputer based on the 740 family core technology.

The 3823 group has the LCD drive control circuit, an 8-channel A/D converter, a serial interface, a watchdog timer, a ROM correction function, and as additional functions.

The various microcomputers in the 3823 group include variations of internal memory size and packaging. For details, refer to the section on part numbering.

FEATURES

- Basic machine-language instructions 71
- The minimum instruction execution time 0.4 μ s
(at $f(XIN) = 10$ MHz, High-speed mode)
- Memory size
 - ROM 16 K to 60 K bytes
 - RAM 640 to 2560 bytes
- ROM correction function 32 bytes X 2 blocks
- Watchdog timer 8-bit X 1
- Programmable input/output ports 49
- Input ports 5
- Software pull-up/pull-down resistors (Ports P0-P7 except port P40)
- Interrupts 17 sources, 16 vectors
(includes key input interrupt)
- Key Input Interrupt (Key-on Wake-Up) 8
- Timers 8-bit X 3, 16-bit X 2
- Serial interface 8-bit X 1 (UART or Clock-synchronized)
- A/D converter 10-bit X 8 channels or 8-bit X 8 channels

● LCD drive control circuit

- Bias 1/2, 1/3
- Duty 1/2, 1/3, 1/4
- Common output 4
- Segment output 32

● Main clock generating circuits Built-in feedback resistor (connect to external ceramic resonator or quartz-crystal oscillator)

● Sub-clock generating circuits (connect to external quartz-crystal oscillator or on-chip oscillator)

● Power source voltage

- In frequency/2 mode ($f(XIN) \leq 10$ MHz) 4.5 to 5.5 V
- In frequency/2 mode ($f(XIN) \leq 8$ MHz) 4.0 to 5.5 V
- In frequency/4 mode ($f(XIN) \leq 10$ MHz) 2.5 to 5.5 V
- In frequency/4 mode ($f(XIN) \leq 8$ MHz) 2.0 to 5.5 V
- In frequency/4 mode ($f(XIN) \leq 5$ MHz) 1.8 to 5.5 V
- In frequency/8 mode ($f(XIN) \leq 10$ MHz) 2.5 to 5.5 V
- In frequency/8 mode ($f(XIN) \leq 8$ MHz) 2.0 to 5.5 V
- In frequency/8 mode ($f(XIN) \leq 5$ MHz) 1.8 to 5.5 V
- In low-speed mode 1.8 to 5.5 V

● Power dissipation

- In frequency/2 mode 18 mW (std.)
(at $f(XIN) = 8$ MHz, $V_{CC} = 5$ V, $T_a = 25$ °C)
- In low-speed mode at X_{CIN} 18 μ W (std.)
(at $f(XIN)$ stopped, $f(X_{CIN}) = 32$ kHz, $V_{CC} = 2.5$ V, $T_a = 25$ °C)
- In low-speed mode at on-chip oscillator 35 μ W (std.)
(at $f(XIN)$ stopped, $f(X_{CIN}) =$ stopped, $V_{CC} = 2.5$ V, $T_a = 25$ °C)

● Operating temperature range - 20 to 85 °C

APPLICATIONS

Camera, audio equipment, household appliances, consumer electronics, etc.

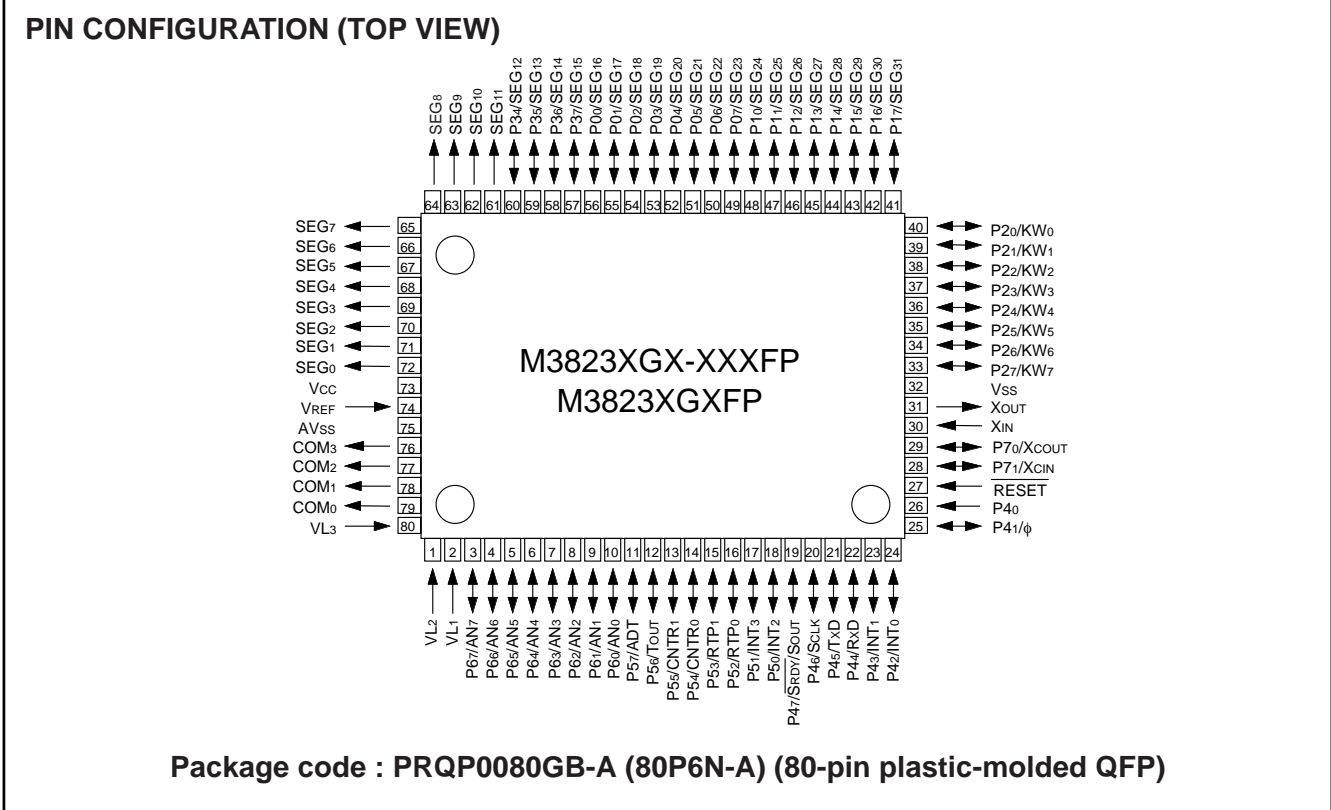

Fig. 1 M3823XGX-XXXFP pin configuration

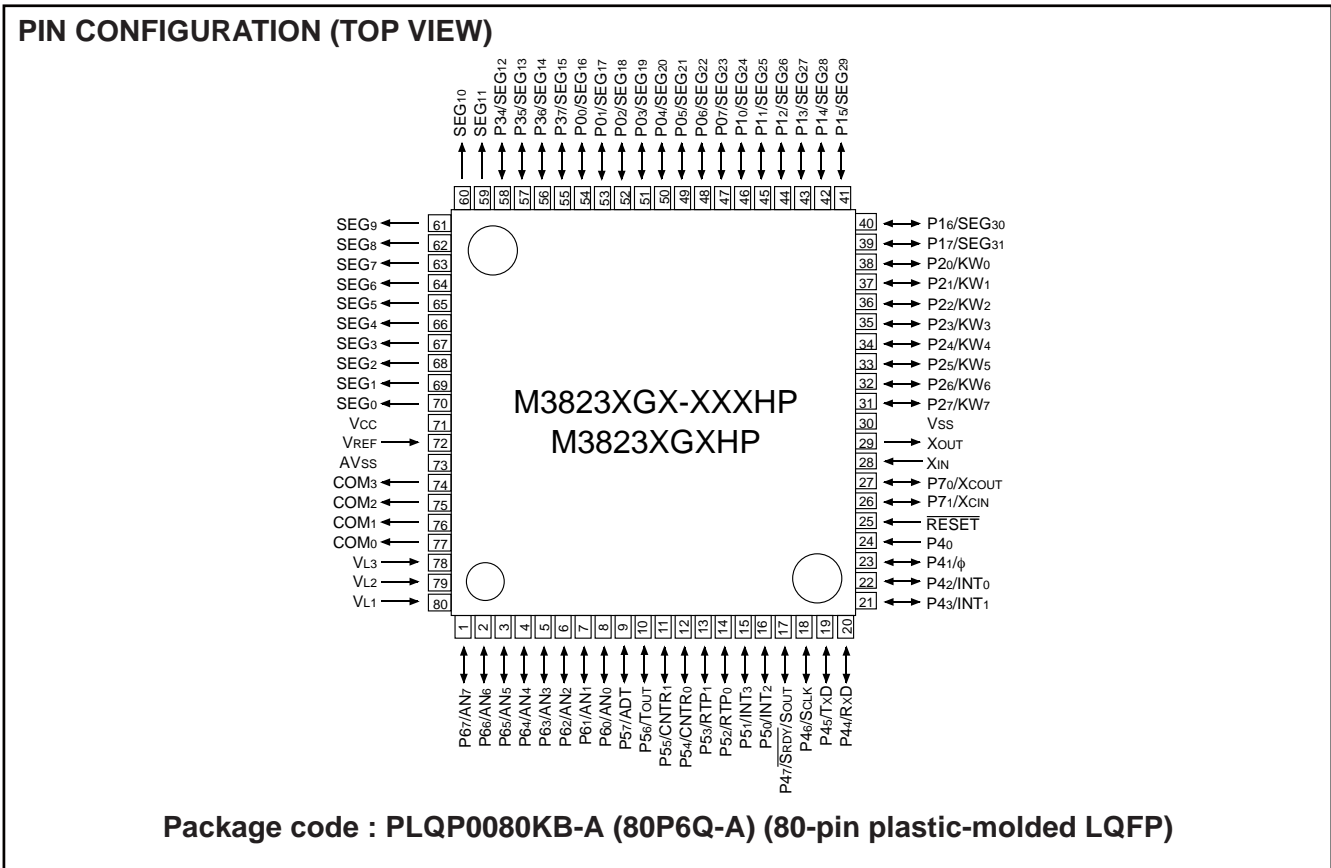

Fig. 2 M3823XGX-XXXHP pin configuration

Table 1 Performance overview

Parameter		Function
Number of basic instructions		71
Instruction execution time		0.4 μ s (Minimum instruction, f(XIN) 10 MHz, High-speed mode)
Oscillation frequency		10 MHz (Maximum)
Memory sizes	ROM	16 K to 60 K bytes
	RAM	640 to 2560 bytes
Input port	P34-P37, P40	4-bit X 1, 1-bit X 1 (4 pins sharing SEG)
I/O port	P0-P2, P41-P47, P5, P6, P70, P71	8-bit X 5, 7-bit X 1, 2 bit X 1 (16 pins sharing SEG)
Interrupt		17 sources, 16 vectors (includes key input interrupt)
Timer		8-bit X 3, 16-bit X 2
Serial interface		8-bit X 1 (UART or Clock-synchronized)
A/D converter		10-bit X 8 channels or 8 bit X 8 channels
Watchdog timer		8-bit X 1
ROM correction function		32 bytes X 2 blocks
LCD drive control circuit	Bias	1/2, 1/3
	Duty	2, 3, 4
	Common output	4
	Segment output	32
Main clock generating circuits		Built-in feedback resistor (connect to external ceramic resonator or quartz-crystal oscillator)
Sub-clock generating circuits		Built-in feedback resistor (connect to external quartz-crystal oscillator or on-chip oscillator)
Power source voltage	In frequency/2 mode (f(XIN) \leq 10MHz)	4.5 to 5.5V
	In frequency/2 mode (f(XIN) \leq 8MHz)	4.0 to 5.5V
	In frequency/4 mode (f(XIN) \leq 10MHz)	2.5 to 5.5V
	In frequency/4 mode (f(XIN) \leq 8MHz)	2.0 to 5.5V
	In frequency/4 mode (f(XIN) \leq 5MHz)	1.8 to 5.5V
	In frequency/8 mode (f(XIN) \leq 10MHz)	2.5 to 5.5V
	In frequency/8 mode (f(XIN) \leq 8MHz)	2.0 to 5.5V
	In frequency/8 mode (f(XIN) \leq 5MHz)	1.8 to 5.5V
	In low-speed mode	1.8 to 5.5V
Power dissipation	In frequency/2 mode	Std. 18 mW (Vcc = 5V, f(XIN) = 8MHz, Ta = 25 °C)
	In low-speed mode at XCIN	Std. 18 μ W (Vcc = 2.5V, f(XIN) = stopped, f(XCIN) = 32kHz, Ta = 25 °C)
	In low-speed mode at on-chip oscillator	Std. 35 μ W (Vcc = 2.5V, f(XIN) = stopped, f(XCIN) = stopped, Ta = 25 °C)
Input/Output characteristics	Input/Output withstand voltage	VCC
	Output current	10mA
Operating temperature range		-20 to 85 °C
Device structure		CMOS silicon gate
Package		80-pin plastic molded LQFP/QFP

FUNCTIONAL BLOCK DIAGRAM (Package type : PLQP0080KB-A)

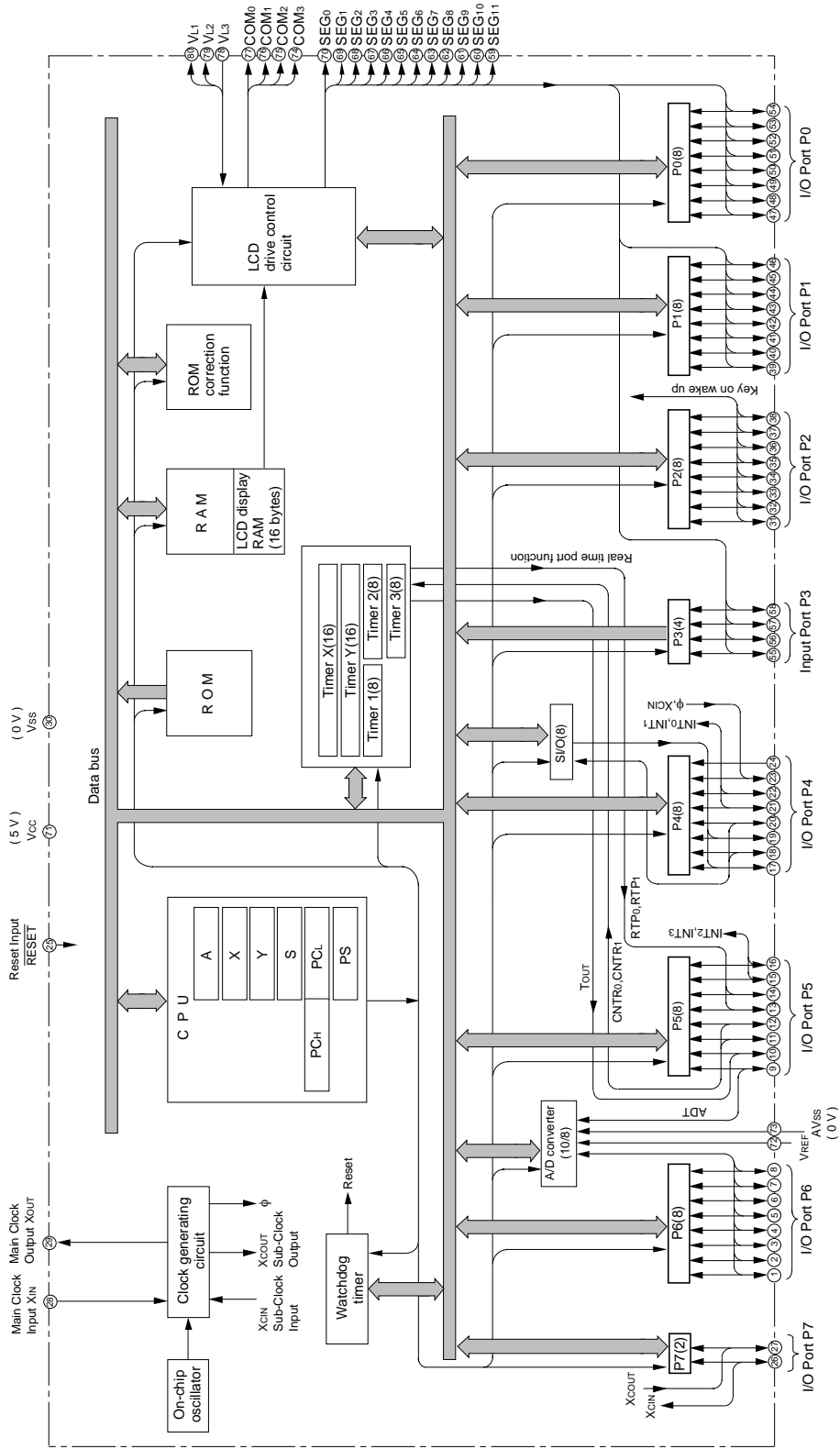

Fig. 3 Functional block diagram

PIN DESCRIPTION

Table 2 Pin description (1)

Pin	Name	Function	
			Function except a port function
VCC, VSS	Power source	<ul style="list-style-type: none"> Apply voltage of power source to VCC, and 0 V to VSS. (For the limits of VCC, refer to "Recommended operating conditions"). 	
VREF	Analog reference voltage	<ul style="list-style-type: none"> Reference voltage input pin for A/D converter. 	
AVSS	Analog power source	<ul style="list-style-type: none"> GND input pin for A/D converter. Connect to VSS. 	
RESET	Reset input	<ul style="list-style-type: none"> Reset input pin for active "L". 	
XIN	Clock input	<ul style="list-style-type: none"> Input and output pins for the main clock generating circuit. Feedback resistor is built in between XIN pin and XOUT pin. 	
XOUT	Clock output	<ul style="list-style-type: none"> Connect a ceramic resonator or a quartz-crystal oscillator between the XIN and XOUT pins to set the oscillation frequency. If an external clock is used, connect the clock source to the XIN pin and leave the XOUT pin open. This clock is used as the oscillating source of system clock. 	
VL1–VL3	LCD power source	<ul style="list-style-type: none"> Input $0 \leq VL1 \leq VL2 \leq VL3$ voltage. Input 0 – VL3 voltage to LCD. 	
COM0–COM3	Common output	<ul style="list-style-type: none"> LCD common output pins. COM2 and COM3 are not used at 1/2 duty ratio. COM3 is not used at 1/3 duty ratio. 	
SEG0–SEG11	Segment output	<ul style="list-style-type: none"> LCD segment output pins. 	
P00/SEG16–P07/SEG23	I/O port P0	<ul style="list-style-type: none"> 8-bit I/O port. CMOS compatible input level. CMOS 3-state output structure. 	<ul style="list-style-type: none"> LCD segment output pins
P10/SEG24–P17/SEG31	I/O port P1	<ul style="list-style-type: none"> I/O direction register allows each port to be individually programmed as either input or output. Pull-down control is enabled. 	
P20/KW0 – P27/KW7	I/O port P2	<ul style="list-style-type: none"> 8-bit I/O port. CMOS compatible input level. CMOS 3-state output structure. I/O direction register allows each pin to be individually programmed as either input or output. Pull-up control is enabled. 	<ul style="list-style-type: none"> Key input (key-on wake-up) interrupt input pins
P34/SEG12 – P37/SEG15	Input port P3	<ul style="list-style-type: none"> 4-bit input port. CMOS compatible input level. Pull-down control is enabled. 	<ul style="list-style-type: none"> LCD segment output pins

Table 3 Pin description (2)

Pin	Name	Function	Function except a port function
P40	Input port P4	<ul style="list-style-type: none"> •1-bit Input port. •CMOS compatible input level. 	<ul style="list-style-type: none"> •QzROM program power pin
P41/ ϕ	I/O port P4	<ul style="list-style-type: none"> •7-bit I/O port. •CMOS compatible input level. •CMOS 3-state output structure. •I/O direction register allows each pin to be individually programmed as either input or output. •Pull-up control is enabled. 	<ul style="list-style-type: none"> •ϕ clock output pin
P42/INT0, P43/INT1			<ul style="list-style-type: none"> •Interrupt input pins
P44/RxD, P45/TxD, P46/SCLK, P47/SRDY/SOUT			<ul style="list-style-type: none"> •Serial interface function pins
P50/INT2, P51/INT3			<ul style="list-style-type: none"> •Interrupt input pins
P52/RTP0, P53/RTP1	I/O port P5	<ul style="list-style-type: none"> •8-bit I/O port. •CMOS compatible input level. •CMOS 3-state output structure. •I/O direction register allows each pin to be individually programmed as either input or output. •Pull-up control is enabled. 	<ul style="list-style-type: none"> •Real time port function pins
P54/CNTR0, P55/CNTR1			<ul style="list-style-type: none"> •Timer X, Y function pins
P56/TOUT			<ul style="list-style-type: none"> •Timer 2 output pins
P57/ADT			<ul style="list-style-type: none"> •A/D trigger input pins
P60/AN0– P67/AN7	I/O port P6	<ul style="list-style-type: none"> •8-bit I/O port. •CMOS compatible input level. •CMOS 3-state output structure. •I/O direction register allows each pin to be individually programmed as either input or output. •Pull-up control is enabled. 	<ul style="list-style-type: none"> •A/D conversion input pins
P70/XCOUT, P71/XCIN	I/O port P7	<ul style="list-style-type: none"> •2-bit I/O port. •CMOS compatible input level. •CMOS 3-state output structure. •I/O direction register allows each pin to be individually programmed as either input or output. •Pull-up control is enabled. 	<ul style="list-style-type: none"> •Sub-clock generating circuit I/O pins. (Connect a resonator. External clock cannot be used.)

PART NUMBERING

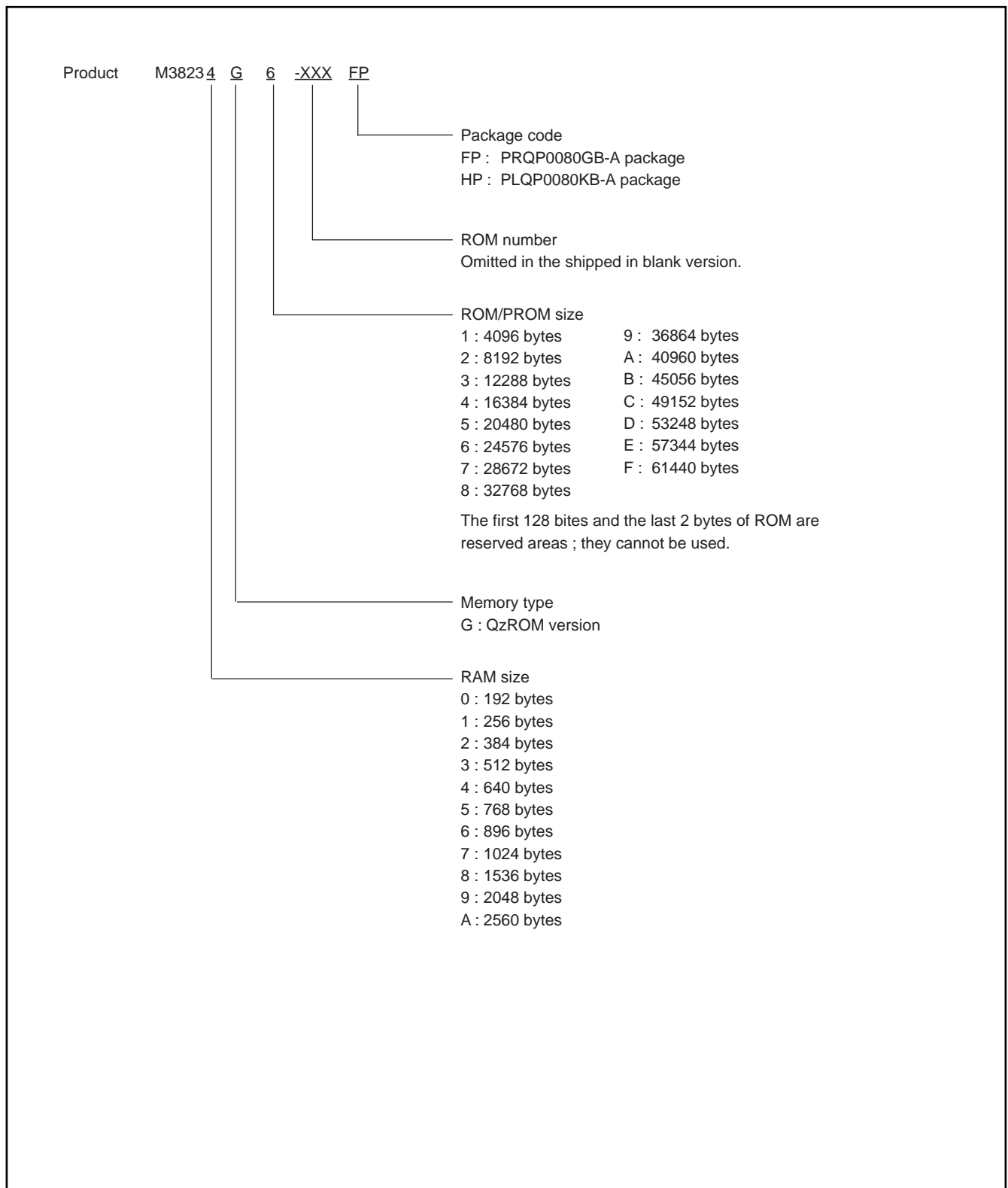

Fig. 4 Part numbering

GROUP EXPANSION

Mitsubishi plans to expand the 3823 group as follows:

Memory Type

Support for QzROM version.

Memory Size

ROM size 16 K to 60 K bytes

RAM size 640 to 2560 bytes

Package

PRQP0080GB-A 0.8 mm-pitch plastic molded QFP

PLQP0080KB-A 0.5 mm-pitch plastic molded LQFP

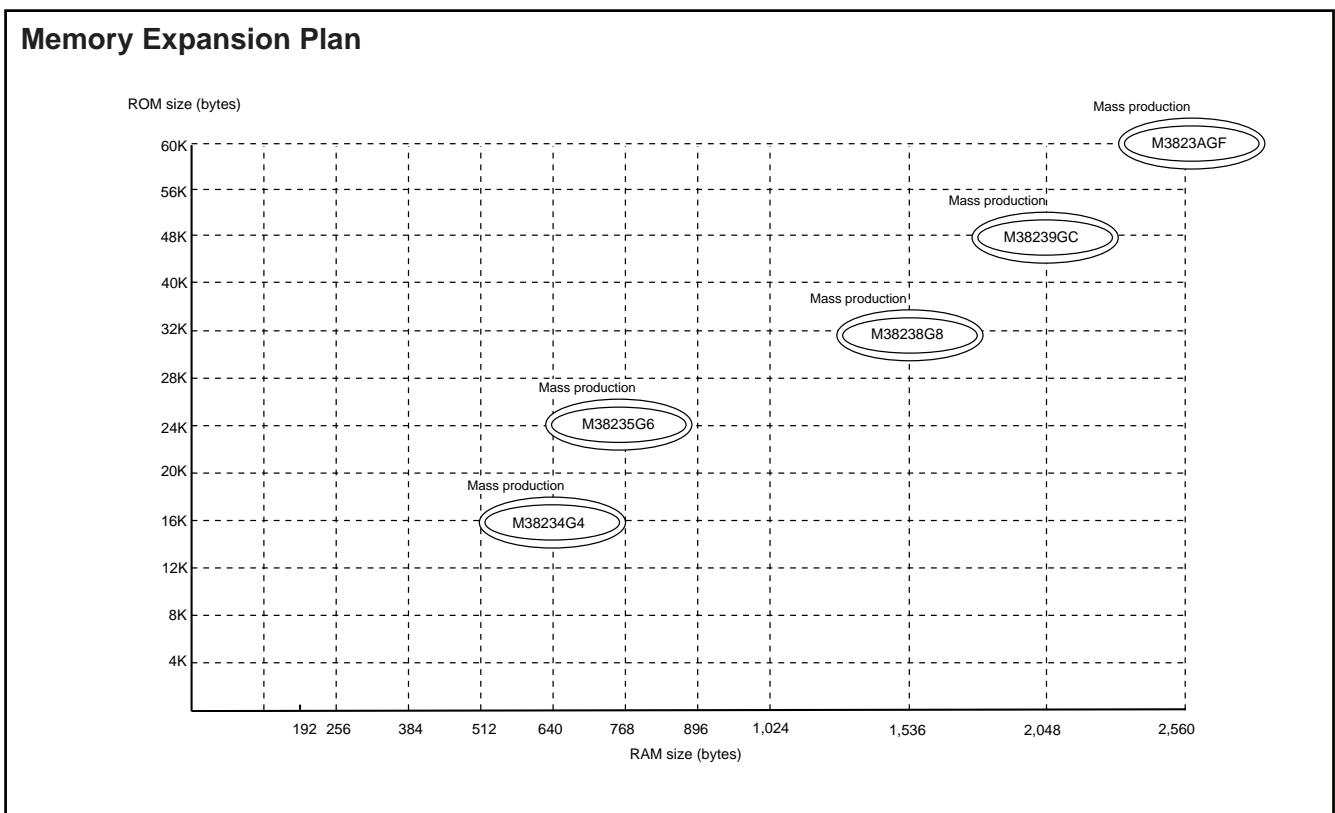

Fig. 5 Memory expansion plan

Currently products are listed below.

Table 4 List of products

Part No.	ROM size (bytes) ROM size for User in ()	RAM size (bytes)	Package	Remarks
M3823AGF-XXXFP	61440 (61310)	2560 (Note 1)	PRQP0080GB-A	
M3823AGF-XXXHP			PLQP0080KB-A	
M3823AGFFP			PRQP0080GB-A	Blank
M3823AGFHP			PLQP0080KB-A	Blank
M38239GC-XXXFP	49152 (49022)	2048 (Note 2)	PRQP0080GB-A	
M38239GC-XXXHP			PLQP0080KB-A	
M38239GCFP			PRQP0080GB-A	Blank
M38239GCHP			PLQP0080KB-A	Blank
M38238G8-XXXFP	32768 (32638)	1536 (Note 2)	PRQP0080GB-A	
M38238G8-XXXHP			PLQP0080KB-A	
M38238G8FP			PRQP0080GB-A	Blank
M38238G8HP			PLQP0080KB-A	Blank
M38235G6-XXXFP	24576 (24446)	768 (Note 2)	PRQP0080GB-A	
M38235G6-XXXHP			PLQP0080KB-A	
M38235G6FP			PRQP0080GB-A	Blank
M38235G6HP			PLQP0080KB-A	Blank
M38234G4-XXXFP	16384 (16254)	640 (Note 2)	PRQP0080GB-A	
M38234G4-XXXHP			PLQP0080KB-A	
M38234G4FP			PRQP0080GB-A	Blank
M38234G4HP			PLQP0080KB-A	Blank

Note 1: RAM size includes RAM for LCD display and ROM corrections.

Note 2: RAM size includes RAM for LCD display.

**FUNCTIONAL DESCRIPTION
CENTRAL PROCESSING UNIT (CPU)**

The 3823 group uses the standard 740 family instruction set. Refer to the table of 740 family addressing modes and machine instructions or the 740 Family Software Manual for details on the instruction set.

Machine-resident 740 family instructions are as follows:
The FST and SLW instruction cannot be used.
The STP, WIT, MUL, and DIV instruction can be used.
The central processing unit (CPU) has six registers. Figure 6 shows the 740 Family CPU register structure.

[Accumulator (A)]

The accumulator is an 8-bit register. Data operations such as data transfer, etc., are executed mainly through the accumulator.

[Index Register X (X)]

The index register X is an 8-bit register. In the index addressing modes, the value of the OPERAND is added to the contents of register X and specifies the real address.

[Index Register Y (Y)]

The index register Y is an 8-bit register. In partial instruction, the value of the OPERAND is added to the contents of register Y and specifies the real address.

[Stack Pointer (S)]

The stack pointer is an 8-bit register used during subroutine calls and interrupts. This register indicates start address of stored area (stack) for storing registers during subroutine calls and interrupts. The low-order 8 bits of the stack address are determined by the contents of the stack pointer. The high-order 8 bits of the stack address are determined by the stack page selection bit. If the stack page selection bit is "0", the high-order 8 bits becomes "0016". If the stack page selection bit is "1", the high-order 8 bits becomes "0116".

The operations of pushing register contents onto the stack and popping them from the stack are shown in Figure 7.

Store registers other than those described in Table 4 with program when the user needs them during interrupts or subroutine calls.

[Program Counter (PC)]

The program counter is a 16-bit counter consisting of two 8-bit registers PCH and PCL. It is used to indicate the address of the next instruction to be executed.

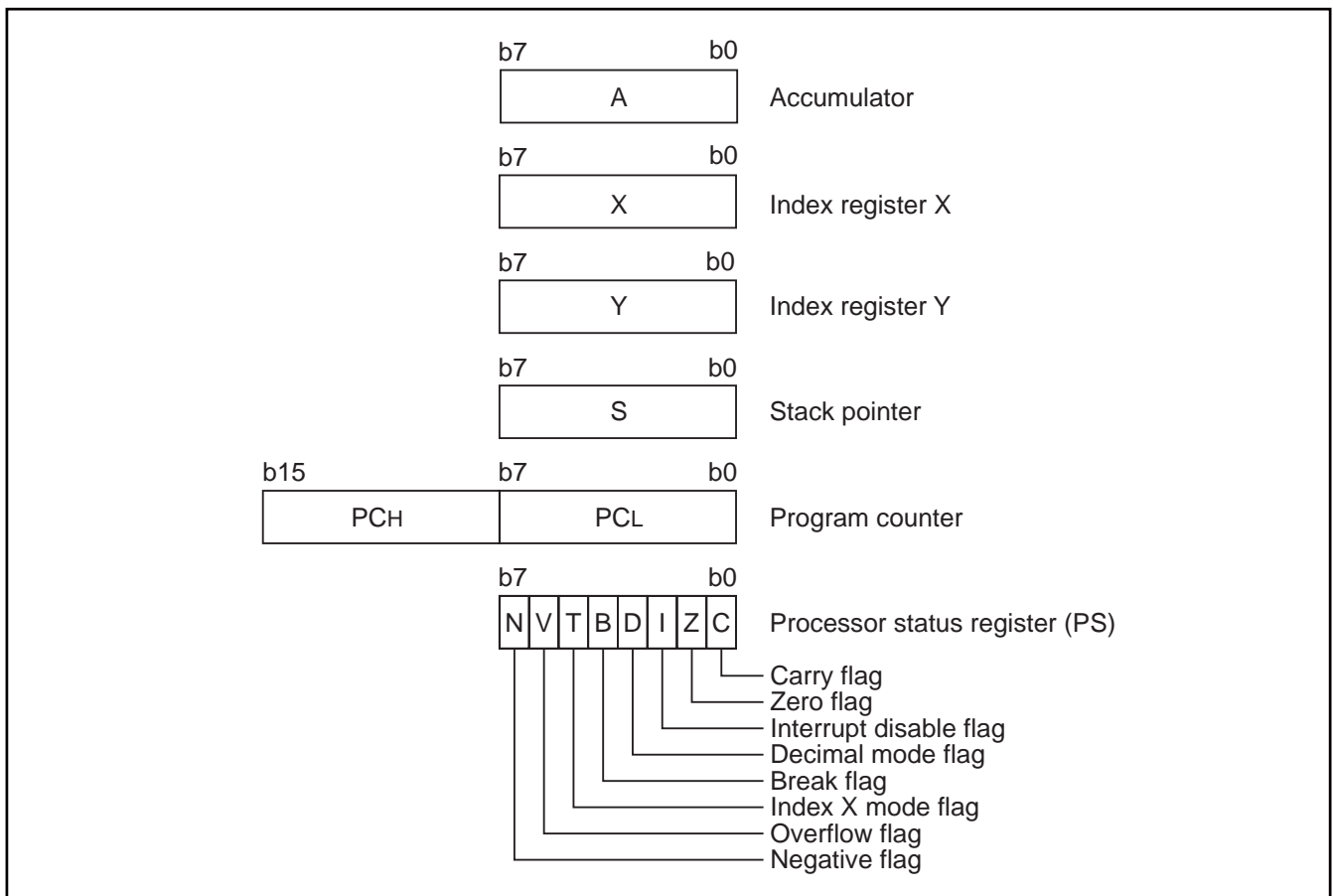

Fig. 6 740 Family CPU register structure

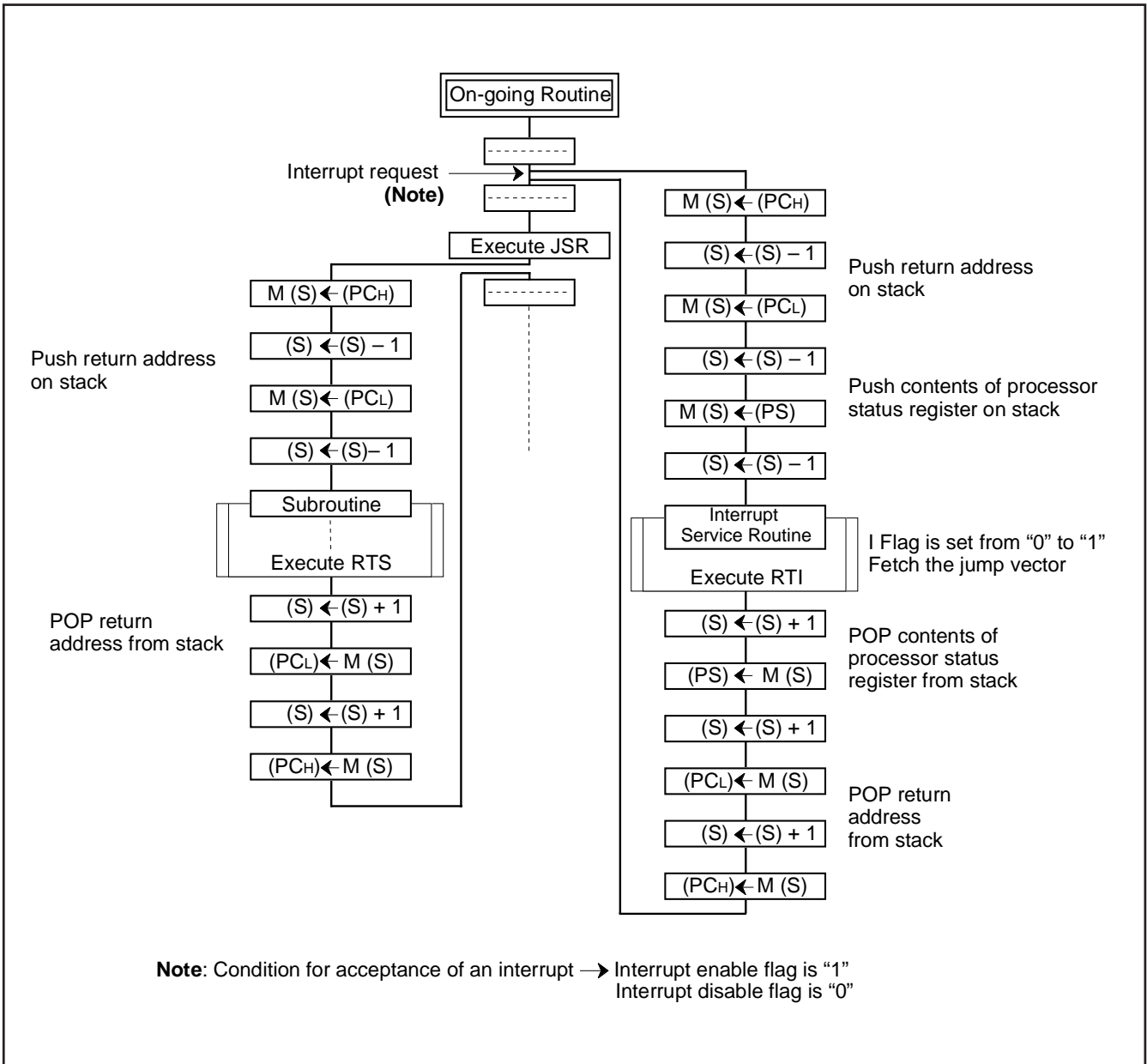

Fig. 7 Register push and pop at interrupt generation and subroutine call

Table 5 Push and pop instructions of accumulator or processor status register

	Push instruction to stack	Pop instruction from stack
Accumulator	PHA	PLA
Processor status register	PHP	PLP

[Processor status register (PS)]

The processor status register is an 8-bit register consisting of 5 flags which indicate the status of the processor after an arithmetic operation and 3 flags which decide MCU operation. Branch operations can be performed by testing the Carry (C) flag, Zero (Z) flag, Overflow (V) flag, or the Negative (N) flag. In decimal mode, the Z, V, N flags are not valid.

•Bit 0: Carry flag (C)

The C flag contains a carry or borrow generated by the arithmetic logic unit (ALU) immediately after an arithmetic operation. It can also be changed by a shift or rotate instruction.

•Bit 1: Zero flag (Z)

The Z flag is set if the result of an immediate arithmetic operation or a data transfer is "0", and cleared if the result is anything other than "0".

•Bit 2: Interrupt disable flag (I)

The I flag disables all interrupts except for the interrupt generated by the BRK instruction.

Interrupts are disabled when the I flag is "1".

•Bit 3: Decimal mode flag (D)

The D flag determines whether additions and subtractions are executed in binary or decimal. Binary arithmetic is executed when this flag is "0"; decimal arithmetic is executed when it is "1".

Decimal correction is automatic in decimal mode. Only the ADC and SBC instructions can be used for decimal arithmetic.

•Bit 4: Break flag (B)

The B flag is used to indicate that the current interrupt was generated by the BRK instruction. The BRK flag in the processor status register is always "0". When the BRK instruction is used to generate an interrupt, the processor status register is pushed onto the stack with the break flag set to "1".

•Bit 5: Index X mode flag (T)

When the T flag is "0", arithmetic operations are performed between accumulator and memory. When the T flag is "1", direct arithmetic operations and direct data transfers are enabled between memory locations.

•Bit 6: Overflow flag (V)

The V flag is used during the addition or subtraction of one byte of signed data. It is set if the result exceeds +127 to -128. When the BIT instruction is executed, bit 6 of the memory location operated on by the BIT instruction is stored in the overflow flag.

•Bit 7: Negative flag (N)

The N flag is set if the result of an arithmetic operation or data transfer is negative. When the BIT instruction is executed, bit 7 of the memory location operated on by the BIT instruction is stored in the negative flag.

Table 6 Set and clear instructions of each bit of processor status register

	C flag	Z flag	I flag	D flag	B flag	T flag	V flag	N flag
Set instruction	SEC	–	SEI	SED	–	SET	–	–
Clear instruction	CLC	–	CLI	CLD	–	CLT	CLV	–

[CPU Mode Register (CPUM)] 003B16

The CPU mode register contains the stack page selection bit and the internal system clock selection bit.

The CPU mode register is allocated at address 003B16.

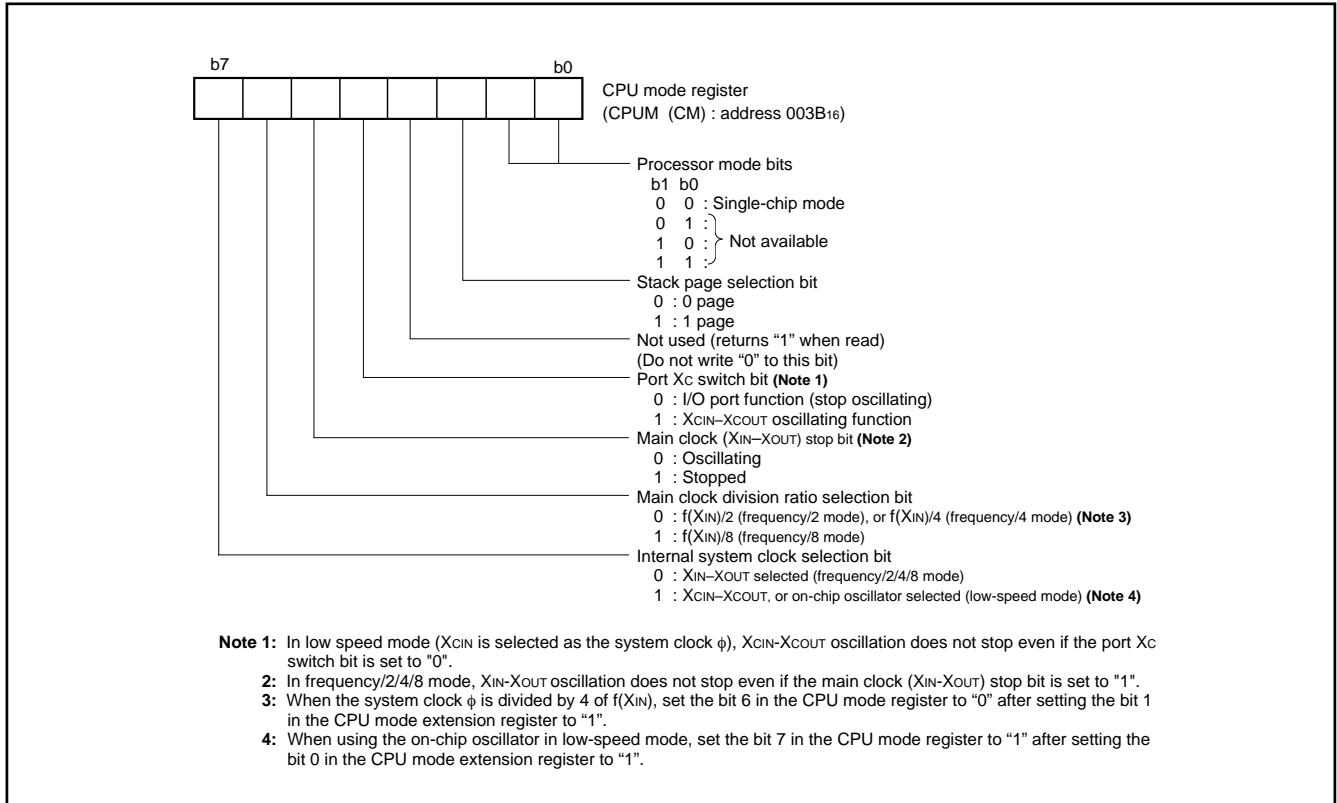

Fig. 8 Structure of CPU mode register

[CPU Mode Extension Register (EXPCM)] 002B16

f(XIN) divided by 4 for the system clock f and the on-chip oscillator for the system clock f in low-speed mode can be selected by setting the CPU mode extension register. When the system clock f is divided by 4 of f(XIN), set the bit 6 in the CPU mode register to "0" after setting the bit 1 in the CPU mode extension register to "1". When using the on-chip oscillator in low-speed mode, set the bit 7 in the CPU mode register to "1" after setting the bit 0 in the CPU mode extension register to "1".

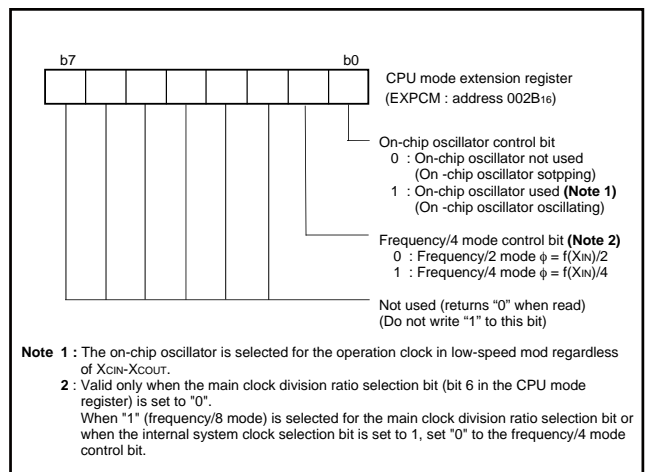

Fig. 9 Structure of CPU mode extension register

MEMORY

Special Function Register (SFR) Area

The Special Function Register area in the zero page contains control registers such as I/O ports and timers.

RAM

RAM is used for data storage and for stack area of subroutine calls and interrupts.

ROM

The first 128 bytes and the last 2 bytes of ROM are reserved for device testing and the rest is user area for storing programs.

Interrupt Vector Area

The interrupt vector area contains reset and interrupt vectors.

Zero Page

The 256 bytes from addresses 0000₁₆ to 00FF₁₆ are called the zero page area. The internal RAM and the special function register (SFR) are allocated to this area.

The zero page addressing mode can be used to specify memory and register addresses in the zero page area. Access to this area with only 2 bytes is possible in the zero page addressing mode.

Special Page

The 256 bytes from addresses FF00₁₆ to FFFF₁₆ are called the special page area. The special page addressing mode can be used to specify memory addresses in the special page area. Access to this area with only 2 bytes is possible in the special page addressing mode.

ROM Code Protect Address

“00₁₆” is written into ROM code protect address (other than the user ROM area) when selecting the protect bit write by using a serial programmer or selecting protect enabled for writing shipment by Renesas Technology corp.. When “00₁₆” is set to the ROM code protect address, the protect function is enabled, so that reading or writing from/to QzROM is disabled by a serial programmer. As for the QzROM product in blank, the ROM code is protected by selecting the protect bit write at ROM writing with a serial programmer.

As for the QzROM product shipped after writing, “00₁₆” (protect enabled) or “FF₁₆” (protect disabled) is written into the ROM code protect address when Renesas Technology corp. performs writing. The writing of “00₁₆” or “FF₁₆” can be selected as ROM option setup (“MASK option” written in the mask file converter) when ordering.

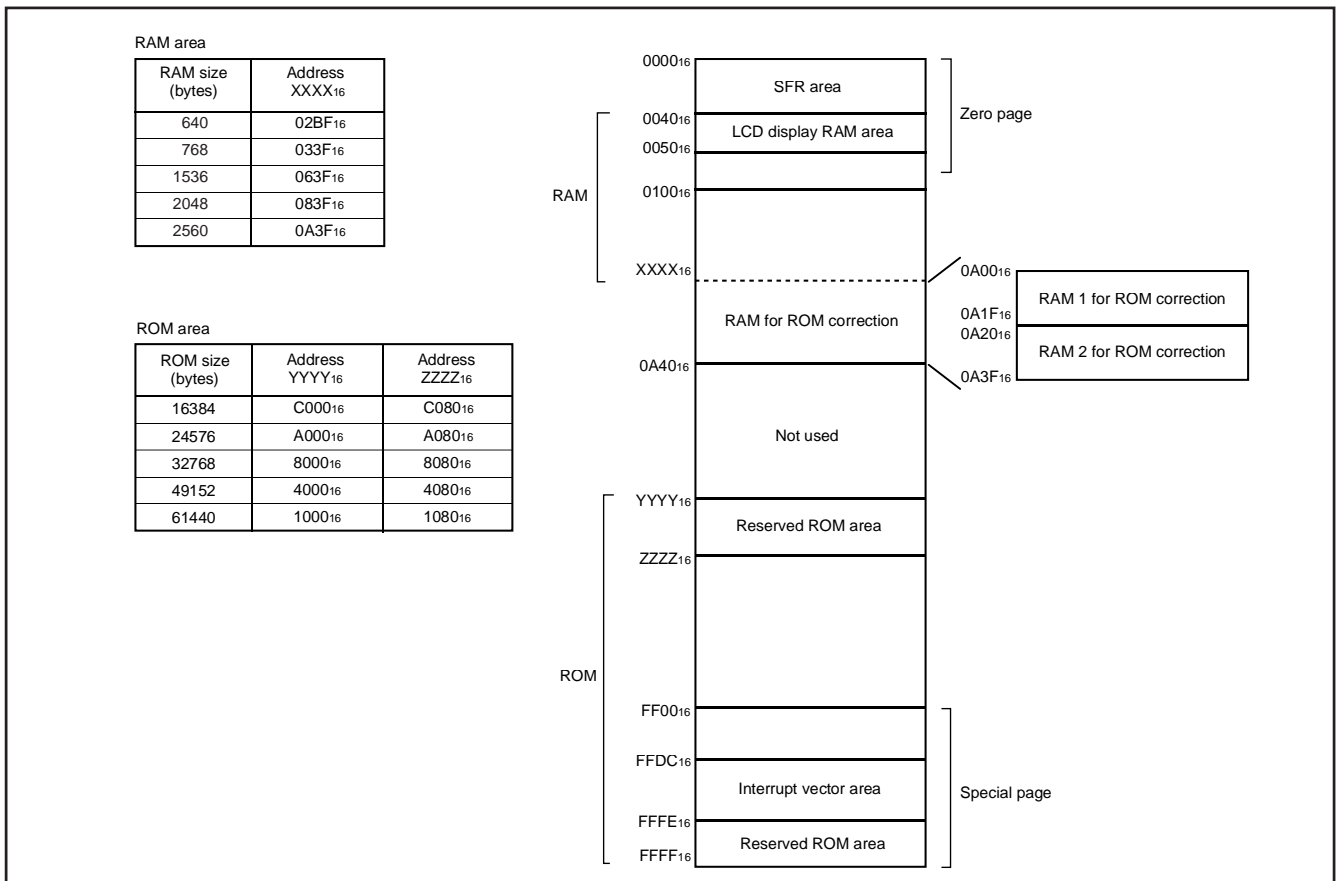

Fig. 10 Memory map diagram

0000 ₁₆	Port P0 register (P0)	0020 ₁₆	Timer X low-order register (TXL)
0001 ₁₆	Port P0 direction register (P0D)	0021 ₁₆	Timer X high-order register (TXH)
0002 ₁₆	Port P1 register (P1)	0022 ₁₆	Timer Y low-order register (TYL)
0003 ₁₆	Port P1 direction register (P1D)	0023 ₁₆	Timer Y high-order register (TYH)
0004 ₁₆	Port P2 register (P2)	0024 ₁₆	Timer 1 register (T1)
0005 ₁₆	Port P2 direction register (P2D)	0025 ₁₆	Timer 2 register (T2)
0006 ₁₆	Port P3 register (P3)	0026 ₁₆	Timer 3 register (T3)
0007 ₁₆		0027 ₁₆	Timer X mode register (TXM)
0008 ₁₆	Port P4 register (P4)	0028 ₁₆	Timer Y mode register (TYM)
0009 ₁₆	Port P4 direction register (P4D)	0029 ₁₆	Timer 123 mode register (T123M)
000A ₁₆	Port P5 register (P5)	002A ₁₆	φ output control register (CKOUT)
000B ₁₆	Port P5 direction register (P5D)	002B ₁₆	CPU mode expansion register (EXPCM)
000C ₁₆	Port P6 register (P6)	002C ₁₆	Temporary data register 0 (TD0)
000D ₁₆	Port P6 direction register (P6D)	002D ₁₆	Temporary data register 1 (TD1)
000E ₁₆	Port P7 register (P7)	002E ₁₆	Temporary data register 2 (TD2)
000F ₁₆	Port P7 direction register (P7D)	002F ₁₆	RRF register (RRFR)
0010 ₁₆	ROM correction address 1 high-order register (RCA1H)	0030 ₁₆	Peripheral function expansion register (EXP)
0011 ₁₆	ROM correction address 1 low-order register (RCA1L)	0031 ₁₆	
0012 ₁₆	ROM correction address 2 high-order register (RCA2H)	0032 ₁₆	
0013 ₁₆	ROM correction address 2 low-order register (RCA2L)	0033 ₁₆	
0014 ₁₆	ROM correction enable register (RCR)	0034 ₁₆	AD control register (ADCON)
0015 ₁₆		0035 ₁₆	AD conversion high-order register (ADH)
0016 ₁₆	PULL register A (PULLA)	0036 ₁₆	AD conversion low-order register (ADL)
0017 ₁₆	PULL register B (PULLB)	0037 ₁₆	Watchdog timer register (WDT)
0018 ₁₆	Transmit/Receive buffer register (TB/RB)	0038 ₁₆	Segment output enable register (SEG)
0019 ₁₆	Serial I/O status register (SIOSTS)	0039 ₁₆	LCD mode register (LM)
001A ₁₆	Serial I/O control register (SIO1CON)	003A ₁₆	Interrupt edge selection register (INTEDGE)
001B ₁₆	UART control register (UARTCON)	003B ₁₆	CPU mode register (CPUM)
001C ₁₆	Baud rate generator (BRG)	003C ₁₆	Interrupt request register 1 (IREQ1)
001D ₁₆		003D ₁₆	Interrupt request register 2 (IREQ2)
001E ₁₆		003E ₁₆	Interrupt control register 1 (ICON1)
001F ₁₆		003F ₁₆	Interrupt control register 2 (ICON2)

Note: Do not access to the SFR area including nothing.

Fig. 11 Memory map of special function register (SFR)

I/O PORTS

Direction Registers (ports P2, P41-P47, and P5-P7)

The 3823 group has 49 programmable I/O pins arranged in seven I/O ports (ports P0-P2, P41-P47 and P5-P7). The I/O ports P2, P41-P47 and P5-P7 have direction registers which determine the input/output direction of each individual pin. Each bit in a direction register corresponds to one pin, and each pin can be set to be input port or output port.

When "0" is written to the bit corresponding to a pin, that pin becomes an input pin. When "1" is written to that bit, that pin becomes an output pin.

If data is read from a pin set to output, the value of the port output latch is read, not the value of the pin itself. Pins set to input are floating. If a pin set to input is written to, only the port output latch is written to and the pin remains floating.

Direction Registers (ports P0 and P1)

Ports P0 and P1 have direction registers which determine the input/output direction of each individual port.

Each port in a direction register corresponds to one port, each port can be set to be input or output. When "0" is written to the bit 0 of a direction register, that port becomes an input port. When "1" is written to that port, that port becomes an output port. Bits 1 to 7 of ports P0 and P1 direction registers are not used.

Ports P3 and P40

These ports are only for input.

Pull-up/Pull-down Control

By setting the PULL register A (address 001616) or the PULL register B (address 001716), ports except for port P40 can control either pull-down or pull-up (pins that are shared with the segment output pins for LCD are pull-down; all other pins are pull-up) with a program.

However, the contents of PULL register A and PULL register B do not affect ports programmed as the output ports.

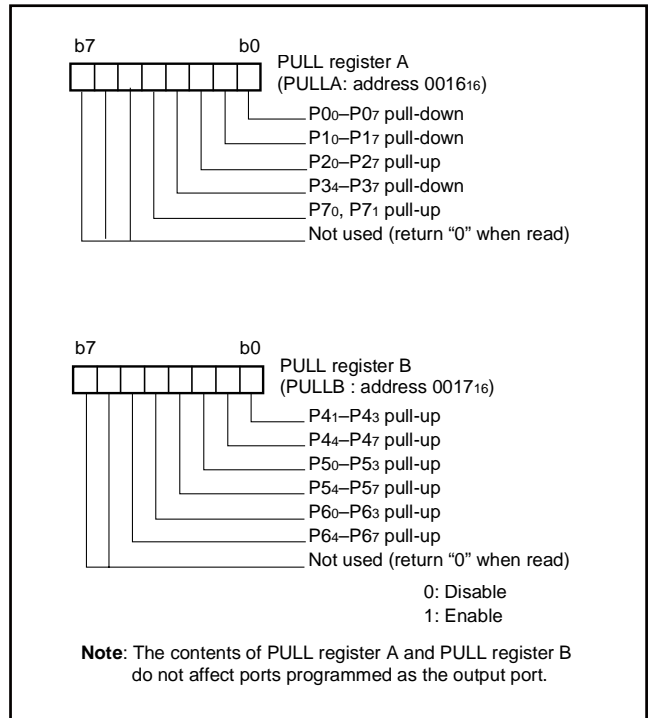

Fig. 12 Structure of PULL register A and PULL register B

Table 7 List of I/O port function

Pin	Name	Input/Output	I/O Format	Non-Port Function	Related SFRs	Diagram No.		
P00/SEG16– P07/SEG23	Port P0	Input/output, individual ports	CMOS compatible input level CMOS 3-state output	LCD segment output	PULL register A Segment output enable register	(1)		
P10/SEG24– P17/SEG31	Port P1							
P20/KW0– P27/KW7	Port P2	Input/output, individual bits	CMOS compatible input level CMOS 3-state output	Key input (key-on wake-up) interrupt input	PULL register A Interrupt control register 2	(2)		
P34/SEG12– P37/SEG15	Port P3	Input	CMOS compatible input level	LCD segment output	PULL register A Segment output enable register	(3)		
P40	Port P4	Input	CMOS compatible input level	QzROM program power pin		(4)		
P41/ ϕ		Input/output, individual bits	CMOS compatible input level CMOS 3-state output	ϕ clock output XCIN frequency signal output	PULL register B ϕ output control register Peripheral function extension register	(5)		
P42/INT0, P43/INT1						External interrupt input	PULL register B Interrupt edge selection register	(2)
P44/RxD						Serial I/O function input/output	PULL register B Serial I/O control register Serial I/O status register UART control register Peripheral function extension register	(6)
P45/TxD								(7)
P46/SCLK								(8)
P47/ $\overline{\text{SRDY}}$ /SOUT								(9)
P50/INT2, P51/INT3	Port P5					Input/output, individual bits	CMOS compatible input level CMOS 3-state output	External interrupt input
P52/RTP0, P53/RTP1		Real time port function output	PULL register B Timer X mode register	(10)				
P54/CNTR0		Timer X function I/O	PULL register B Timer X mode register	(11)				
P55/CNTR1		Timer Y function input	PULL register B Timer Y mode register	(12)				
P56/TOUT		Timer 2 function output	PULL register B Timer 123 mode register	(13)				
P57/ADT		A/D trigger input	PULL register B	(12)				
P60/AN0– P67/AN7	Port P6	Input/output, individual bits	CMOS compatible input level CMOS 3-state output	A/D conversion input	A/D control register	(14)		
P70/XCOUT	Port P7	Input/output, individual bits	CMOS compatible input level CMOS 3-state output	Sub-clock generating circuit I/O	PULL register A CPU mode register	(15)		
P71/XCIN						(16)		
COM0–COM3	Common	Output	LCD common output		LCD mode register	(17)		
SEG0–SEG11	Segment	Output	LCD segment output			(18)		

Notes 1: For details of how to use double function ports as function I/O ports, refer to the applicable sections.

2: When an input level is at an intermediate potential, a current will flow from Vcc to Vss through the input-stage gate. Especially, power source current may increase during execution of the STP and WIT instructions. Fix the unused input pins to "H" or "L" through a resistor.

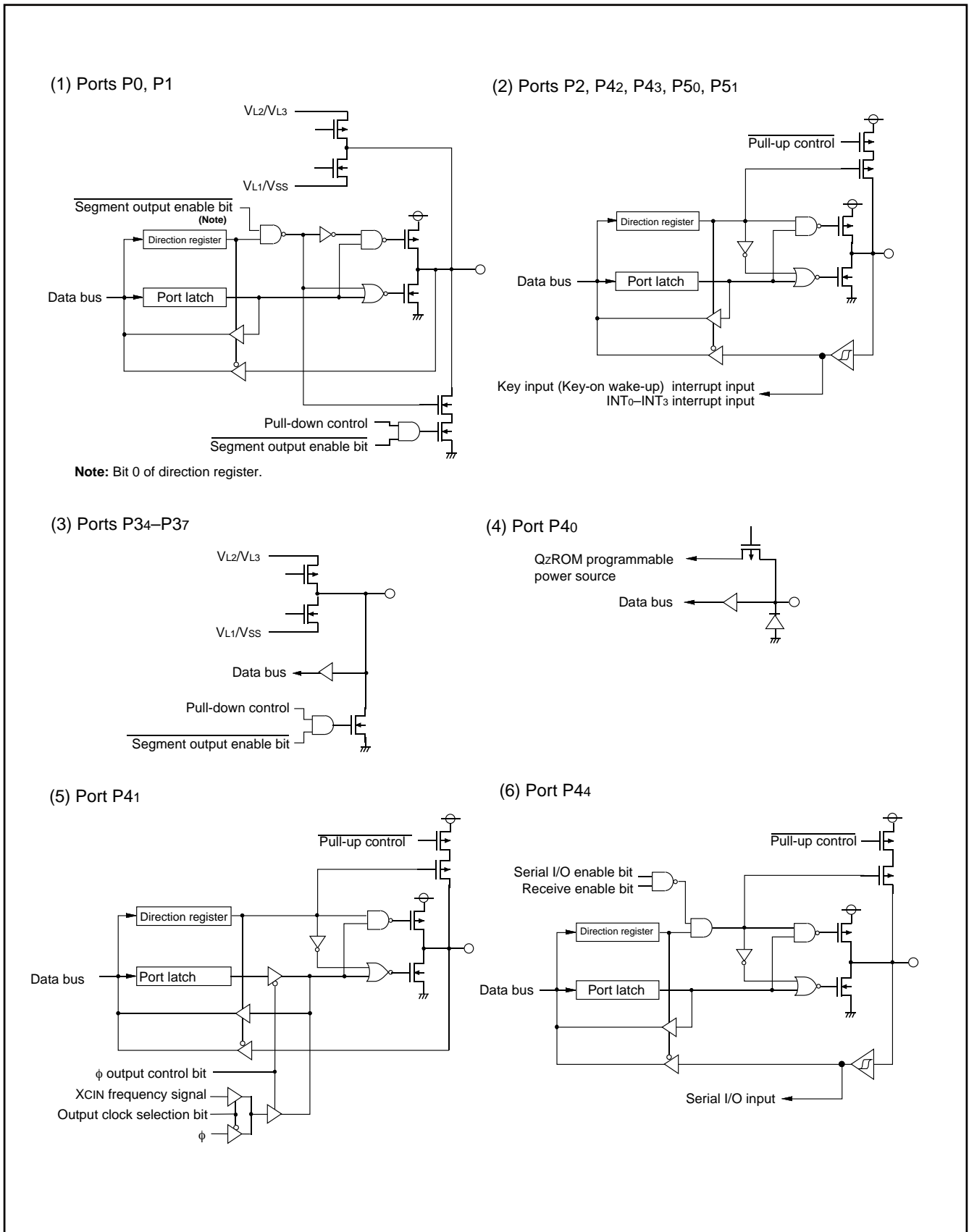

Fig. 13 Port block diagram (1)

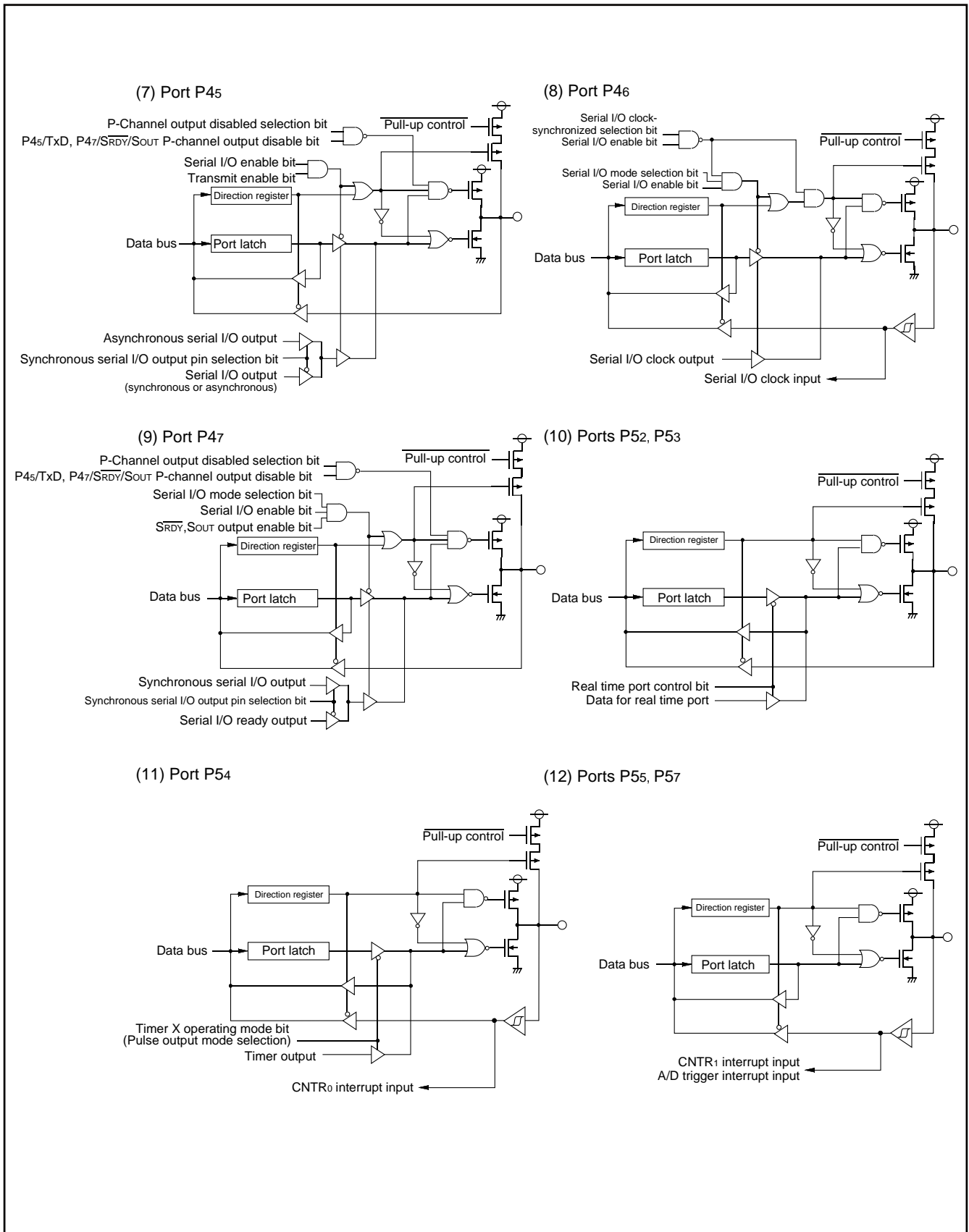

Fig. 14 Port block diagram (2)

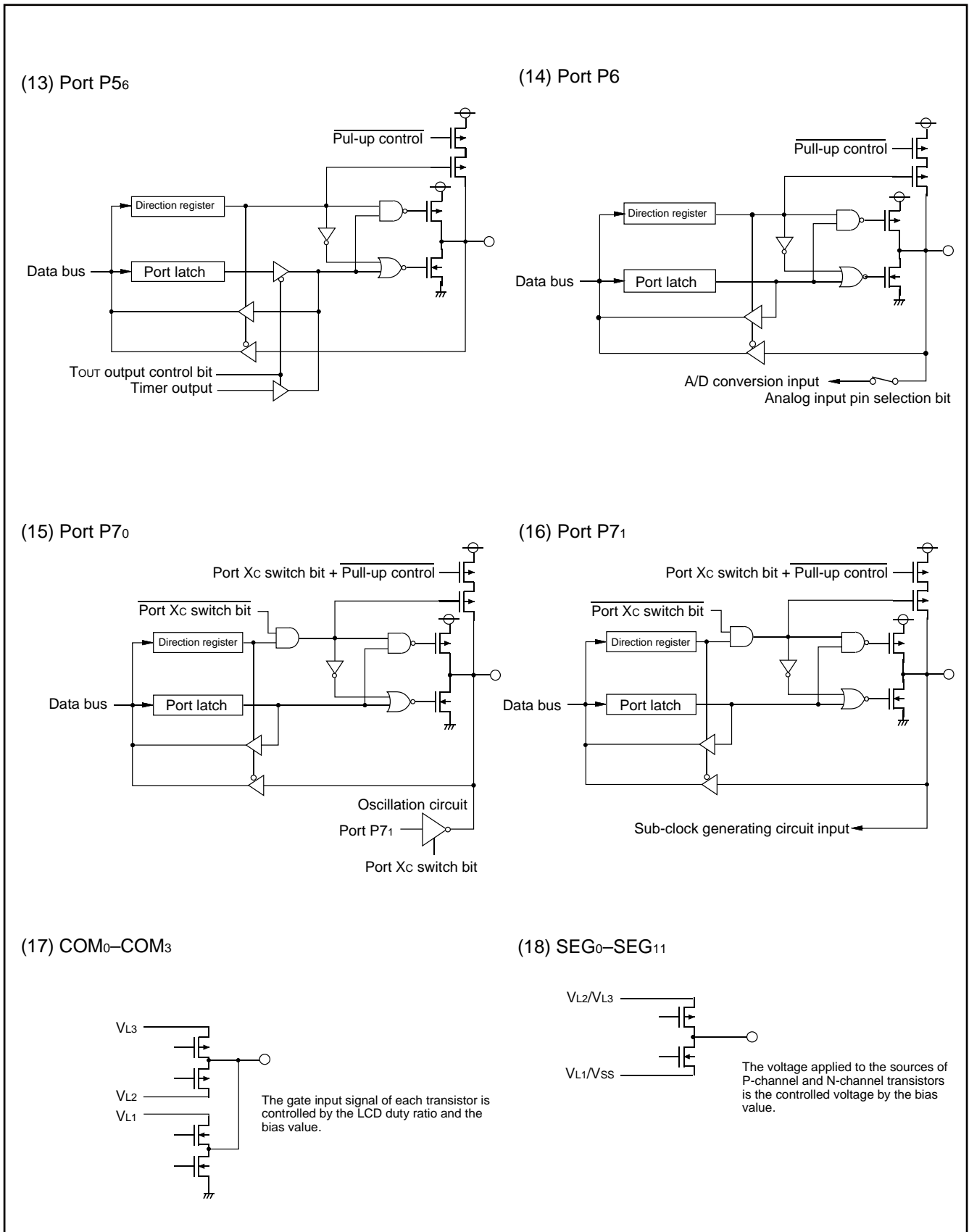

Fig. 15 Port block diagram (3)

Termination of unused pins

- Termination of common pins

I/O ports: Select an input port or an output port and follow each processing method.

Output ports: Open.

Input ports: If the input level become unstable, through current flow to an input circuit, and the power supply current may increase.

Especially, when expecting low consumption current (at STP or WIT instruction execution etc.), pull-up or pull-down input ports to prevent through current (built-in resistor can be used). Pull-down the P40/(VPP) pin.

We recommend processing unused pins through a resistor which can secure $I_{OH(ave)}$ or $I_{OL(ave)}$.

Because, when an I/O port or a pin which have an output function is selected as an input port, it may operate as an output port by incorrect operation etc.

Table 8 Termination of unused pins

Pin	Termination 1 (recommend)	Termination 2	Termination 3
P00/SEG16–P17/SEG23	I/O port	When selecting SEG output, open.	–
P10/SEG24–P17/SEG31		When selecting KW function, perform termination of input port.	–
P20/KW0–P27/KW7			–
P34/SEG12–P37/SEG15	Input port	When selecting SEG output, open.	–
P40/(VPP)	Input port (pull-down)	–	–
P41/φ	I/O port	When selecting φ output, open.	–
P42/INT0		When selecting INT0 function, perform termination of input port.	–
P43/INT1		When selecting INT1 function, perform termination of input port.	–
P44/RxD		When selecting RxD function, perform termination of input port.	–
P45/TxD		When selecting TxD function, perform termination of output port.	–
P46/SCLK		When selecting external clock input, perform termination of input port.	When selecting internal clock output, perform termination of output port.
P47/SRDY/SOUT		When selecting SRDY function, perform termination of output port.	When selecting SOUT function, perform termination of output port.
P50/INT2		When selecting INT2 function, perform termination of input port.	–
P51/INT3		When selecting INT3 function, perform termination of input port.	–
P52/RTP0		When selecting RTP0 function, perform termination of output port.	–
P53/RTP1		When selecting RTP1 function, perform termination of output port.	–
P54/CNTR0		When selecting CNTR0 input function, perform termination of input port.	When selecting CNTR0 output function, perform termination of output port.
P55/CNTR1		When selecting CNTR1 function, perform termination of input port.	–
P56/TOUT		When selecting TOUT function, perform termination of output port.	–
P57/ADT		When selecting ADT function, perform termination of input port.	–
P60/AN0–P67/AN7		When selecting AN function, these pins can be opened. (A/D conversion result cannot be guaranteed.)	–
P70/XCOUT P71/XCIN	Do not select XCIN-XCOUT oscillation function by program.	–	
VL3 (Note)	Connect to VSS	–	–
VL2 (Note)	Connect to VSS	–	–
VL1 (Note)	Connect to VSS	–	–
COM0–COM3	Open	–	–
SEG0–SEG11	Open	–	–
AVSS	Connect to VSS	–	–
VREF	Connect to VCC or VSS	–	–
XOUT	When an external clock is input to the XIN pin, leave the XOUT pin open.	–	–

Note : The termination of VL3, VL2 and VL1 is applied when the bit 3 of the LCD mode register is "0"

INTERRUPTS

The 3823 group interrupts are vector interrupts with a fixed priority scheme, and generated by 16 sources among 17 sources: 8 external, 8 internal, and 1 software.

The interrupt sources, vector addresses ⁽¹⁾, and interrupt priority are shown in Table 9.

Each interrupt except the BRK instruction interrupt has the interrupt request bit and the interrupt enable bit. These bits and the interrupt disable flag (I flag) control the acceptance of interrupt requests. Figure 16 shows an interrupt control diagram.

An interrupt requests is accepted when all of the following conditions are satisfied:

- Interrupt disable flag.....“0”
- Interrupt disable request bit“1”
- Interrupt enable bit.....“1”

Though the interrupt priority is determined by hardware, priority processing can be performed by software using the above bits and flag.

Table 9 Interrupt vector addresses and priority

Interrupt Source	Priority	Vector Addresses (Note 1)		Interrupt Request Generating Conditions	Remarks
		High	Low		
Reset (Note 2)	1	FFFD ₁₆	FFFC ₁₆	At reset	Non-maskable
INT ₀	2	FFFB ₁₆	FFFA ₁₆	At detection of either rising or falling edge of INT ₀ input	External interrupt (active edge selectable)
INT ₁	3	FFF9 ₁₆	FFF8 ₁₆	At detection of either rising or falling edge of INT ₁ input	External interrupt (active edge selectable)
Serial I/O reception	4	FFF7 ₁₆	FFF6 ₁₆	At completion of serial interface data reception	Valid when serial interface is selected
Serial I/O transmission	5	FFF5 ₁₆	FFF4 ₁₆	At completion of serial interface transmit shift or when transmission buffer is empty	Valid when serial interface is selected
Timer X	6	FFF3 ₁₆	FFF2 ₁₆	At timer X underflow	
Timer Y	7	FFF1 ₁₆	FFF0 ₁₆	At timer Y underflow	
Timer 2	8	FFEF ₁₆	FFEE ₁₆	At timer 2 underflow	
Timer 3	9	FFED ₁₆	FFEC ₁₆	At timer 3 underflow	
CNTR ₀	10	FFE _B ₁₆	FFE _A ₁₆	At detection of either rising or falling edge of CNTR ₀ input	External interrupt (active edge selectable)
CNTR ₁	11	FFE ₉ ₁₆	FFE ₈ ₁₆	At detection of either rising or falling edge of CNTR ₁ input	External interrupt (active edge selectable)
Timer 1	12	FFE ₇ ₁₆	FFE ₆ ₁₆	At timer 1 underflow	
INT ₂	13	FFE ₅ ₁₆	FFE ₄ ₁₆	At detection of either rising or falling edge of INT ₂ input	External interrupt (active edge selectable)
INT ₃	14	FFE ₃ ₁₆	FFE ₂ ₁₆	At detection of either rising or falling edge of INT ₃ input	External interrupt (active edge selectable)
Key input (Key-on wake-up)	15	FFE ₁ ₁₆	FFE ₀ ₁₆	At falling of conjunction of input level for port P2 (at input mode)	External interrupt (Valid at falling)
ADT	16	FFDF ₁₆	FFDE ₁₆	At falling of ADT input	Valid when ADT interrupt is selected, External interrupt (Valid at falling)
A/D conversion				At completion of A/D conversion	Valid when A/D interrupt is selected
BRK instruction	17	FFDD ₁₆	FFDC ₁₆	At BRK instruction execution	Non-maskable software interrupt

Notes1: Vector addresses contain interrupt jump destination addresses.

2: Reset function in the same way as an interrupt with the highest priority.

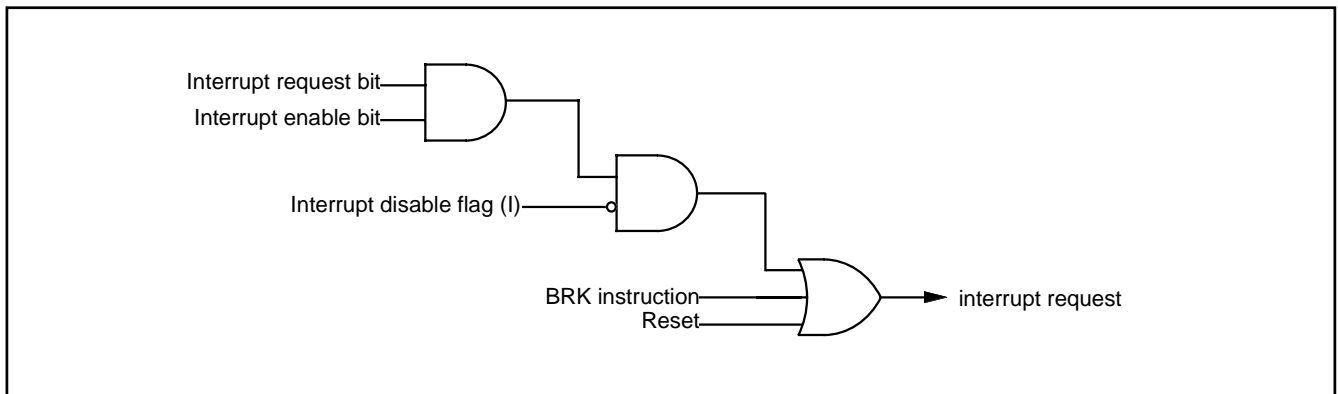

Fig. 16 Interrupt control diagram

Interrupt Disable Flag

The interrupt disable flag is assigned to bit 2 of the processor status register. This flag controls the acceptance of all interrupt requests except for the BRK instruction. When this flag is set to "1", the acceptance of interrupt requests is disabled. When it is set to "0", acceptance of interrupt requests is enabled. This flag is set to "1" with the SET instruction and set to "0" with the CLI instruction.

When an interrupt request is accepted, the contents of the processor status register are pushed onto the stack while the interrupt disable flag remains set to "0". Subsequently, this flag is automatically set to "1" and multiple interrupts are disabled.

To use multiple interrupts, set this flag to "0" with the CLI instruction within the interrupt processing routine.

The contents of the processor status register are popped off the stack with the RTI instruction.

Interrupt Request Bits

Once an interrupt request is generated, the corresponding interrupt request bit is set to "1" and remains "1" until the request is accepted. When the request is accepted, this bit is automatically set to "0".

Each interrupt request bit can be set to "0", but cannot be set to "1", by software.

Interrupt Enable Bits

The interrupt enable bits control the acceptance of the corresponding interrupt requests. When an interrupt enable bit is set to "0", the acceptance of the corresponding interrupt request is disabled. If an interrupt request occurs in this condition, the corresponding interrupt request bit is set to "1", but the interrupt request is not accepted. When an interrupt enable bit is set to "1", acceptance of the corresponding interrupt request is enabled.

Each interrupt enable bit can be set to "0" or "1" by software.

The interrupt enable bit for an unused interrupt should be set to "0".

Interrupt Source Selection

The following combinations can be selected by the interrupt source selection bit of the AD control register (bit 6 of the address 0039₁₆).

- ADT or A/D conversion (refer Table 9)

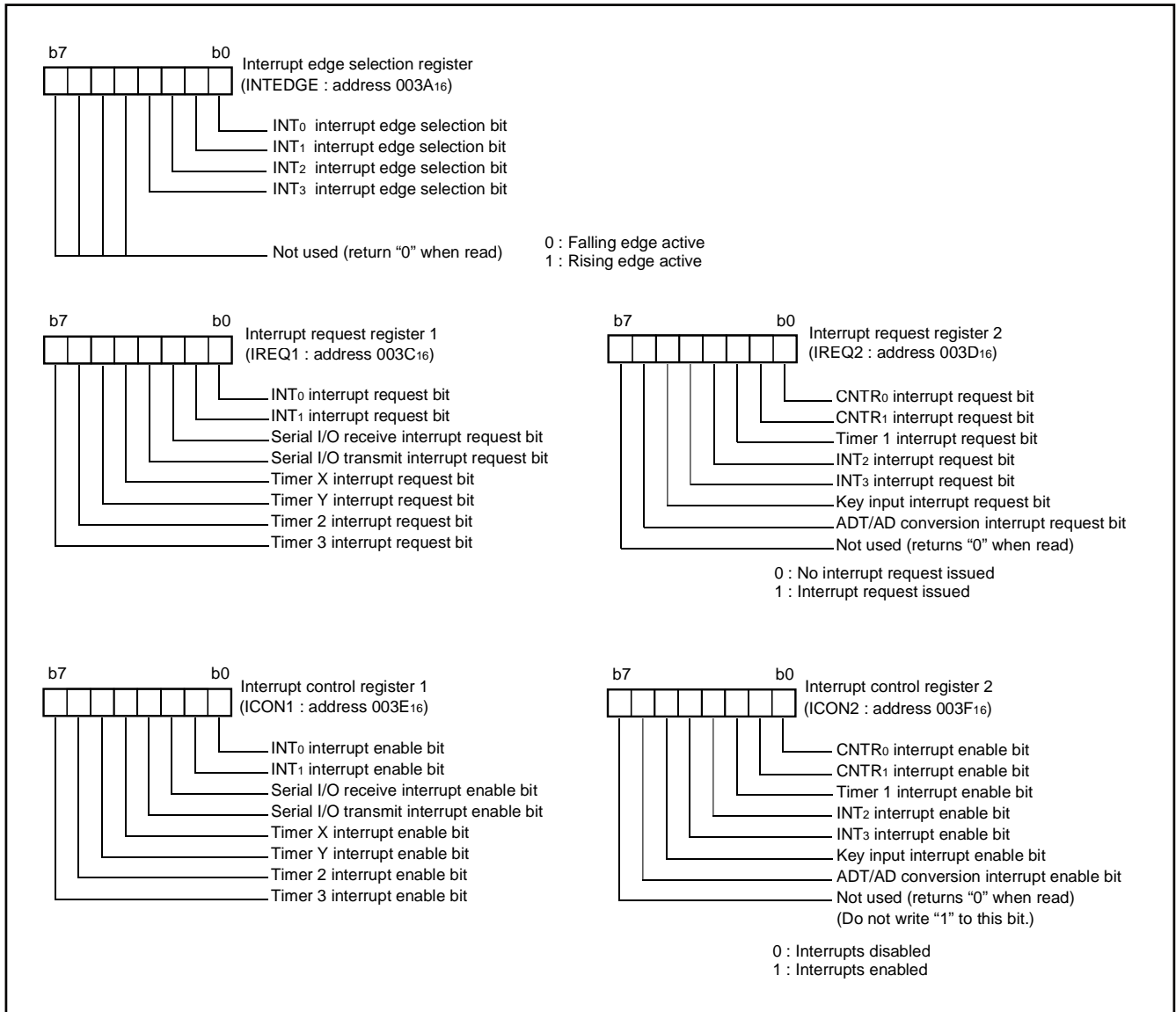

Fig. 17 Structure of interrupt-related registers

Interrupt Request Generation, Acceptance, and Handling

Interrupts have the following three phases.

- (i) **Interrupt Request Generation**
An interrupt request is generated by an interrupt source (external interrupt signal input, timer underflow, etc.) and the corresponding request bit is set to "1".
- (ii) **Interrupt Request Acceptance**
Based on the interrupt acceptance timing in each instruction cycle, the interrupt control circuit determines acceptance conditions (interrupt request bit, interrupt enable bit, and interrupt disable flag) and interrupt priority levels for accepting interrupt requests. When two or more interrupt requests are generated simultaneously, the highest priority interrupt is accepted. The value of interrupt request bit for an unaccepted interrupt remains the same and acceptance is determined at the next interrupt acceptance timing point.
- (iii) **Handling of Accepted Interrupt Request**
The accepted interrupt request is processed.

Figure 18 shows the time up to execution in the interrupt processing routine, and Figure 19 shows the interrupt sequence. Figure 20 shows the timing of interrupt request generation, interrupt request bit, and interrupt request acceptance.

Interrupt Handling Execution

When interrupt handling is executed, the following operations are performed automatically.

- (1) Once the currently executing instruction is completed, an interrupt request is accepted.
- (2) The contents of the program counters and the processor status register at this point are pushed onto the stack area in order from 1 to 3.
 1. High-order bits of program counter (PCH)
 2. Low-order bits of program counter (PCL)
 3. Processor status register (PS)
- (3) Concurrently with the push operation, the jump address of the corresponding interrupt (the start address of the interrupt processing routine) is transferred from the interrupt vector to the program counter.
- (4) The interrupt request bit for the corresponding interrupt is set to "0". Also, the interrupt disable flag is set to "1" and multiple interrupts are disabled.
- (5) The interrupt routine is executed.
- (6) When the RTI instruction is executed, the contents of the registers pushed onto the stack area are popped off in the order from 3 to 1. Then, the routine that was before running interrupt processing resumes.

As described above, it is necessary to set the stack pointer and the jump address in the vector area corresponding to each interrupt to execute the interrupt processing routine.

Notes

The interrupt request bit may be set to "1" in the following cases.

- When setting the external interrupt active edge
Related registers: Interrupt edge selection register (address 003A16)
Timer X mode register (address 002716)
Timer Y mode register (address 002816)

If it is not necessary to generate an interrupt synchronized with these settings, take the following sequence.

- (1) Set the corresponding enable bit to "0" (disabled).
- (2) Set the interrupt edge selection bit (the active edge switch bit) or the interrupt source bit.
- (3) Set the corresponding interrupt request bit to "0" after one or more instructions have been executed.
- (4) Set the corresponding interrupt enable bit to "1" (enabled).

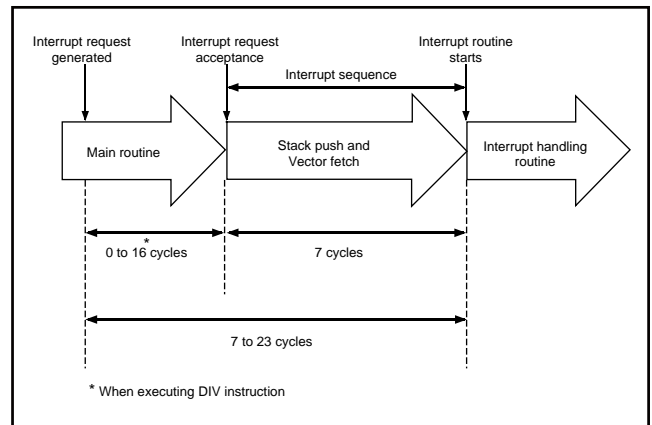

Fig. 18 Time up to execution in interrupt routine

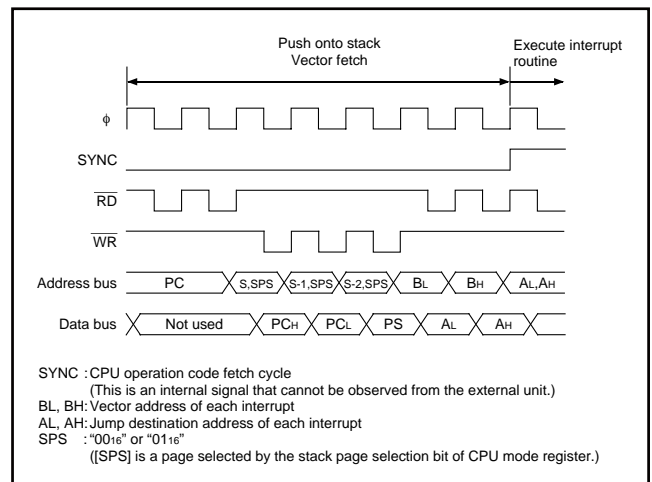

Fig. 19 Interrupt sequence

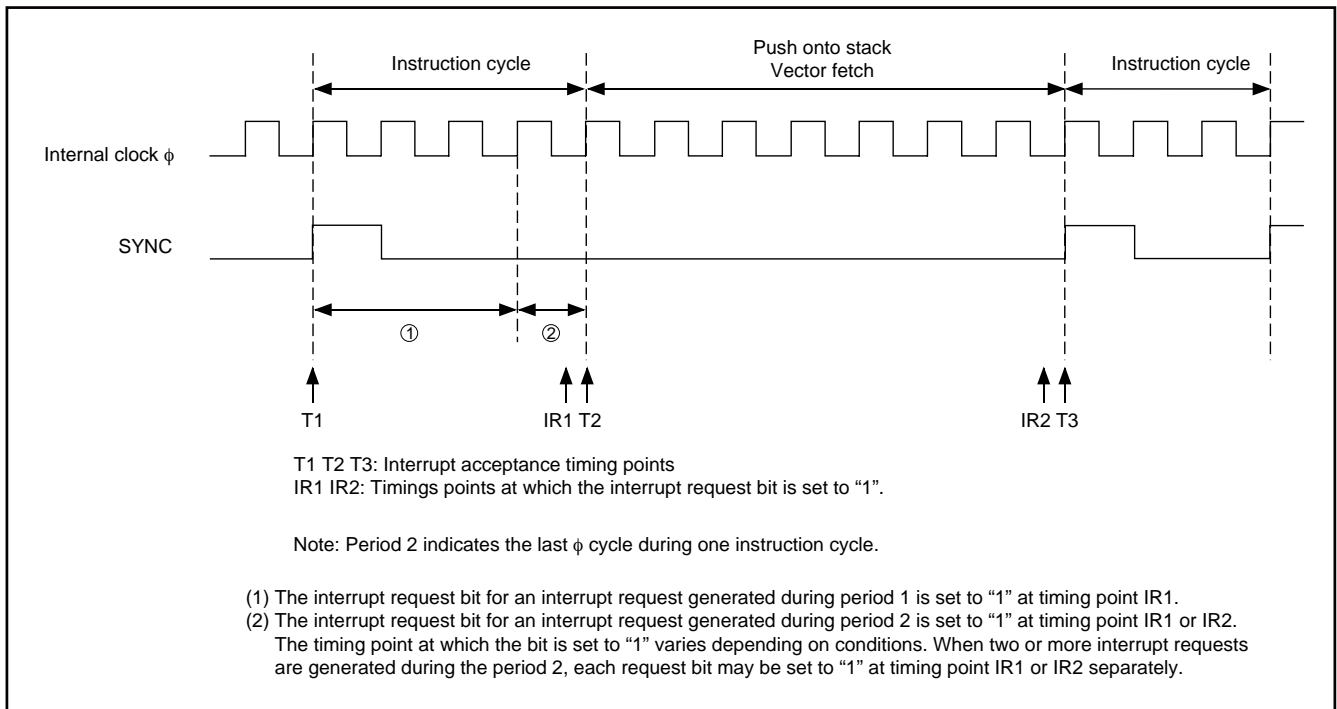

Fig. 20 Timing of interrupt request generation, interrupt request bit, and interrupt acceptance

Key Input Interrupt (Key-on wake-up)

A Key-on wake-up interrupt request is generated by applying a falling edge to any pin of port P2 that have been set to input mode. In other words, it is generated when AND of input level goes from

"1" to "0". An example of using a key input interrupt is shown in Figure 21, where an interrupt request is generated by pressing one of the keys consisted as an active-low key matrix which inputs to ports P20–P23.

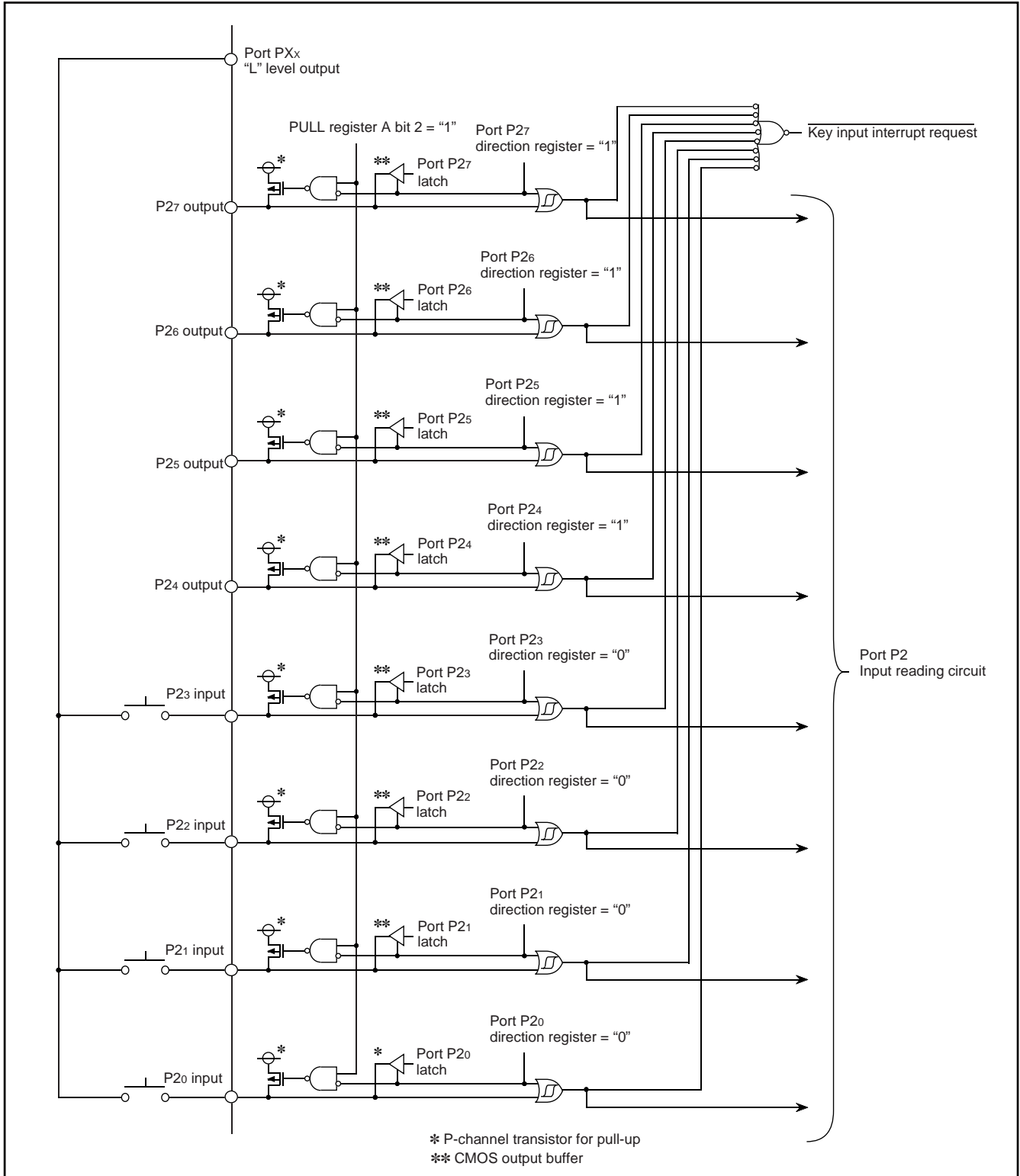

Fig. 21 Connection example when using key input interrupt and port P2 block diagram

TIMERS

The 3823 group has five timers: timer X, timer Y, timer 1, timer 2, and timer 3. Timer X and timer Y are 16-bit timers, and timer 1, timer 2, and timer 3 are 8-bit timers.

All timers are down count timers. When the timer reaches "0016", an underflow occurs at the next count pulse and the corresponding timer latch is reloaded into the timer and the count is continued. When a timer underflows, the interrupt request bit cor-

responding to that timer is set to "1".

Read and write operation on 16-bit timer must be performed for both high and low-order bytes. When reading a 16-bit timer, read the high-order byte first. When writing to a 16-bit timer, write the low-order byte first. The 16-bit timer cannot perform the correct operation when reading during the write operation, or when writing during the read operation.

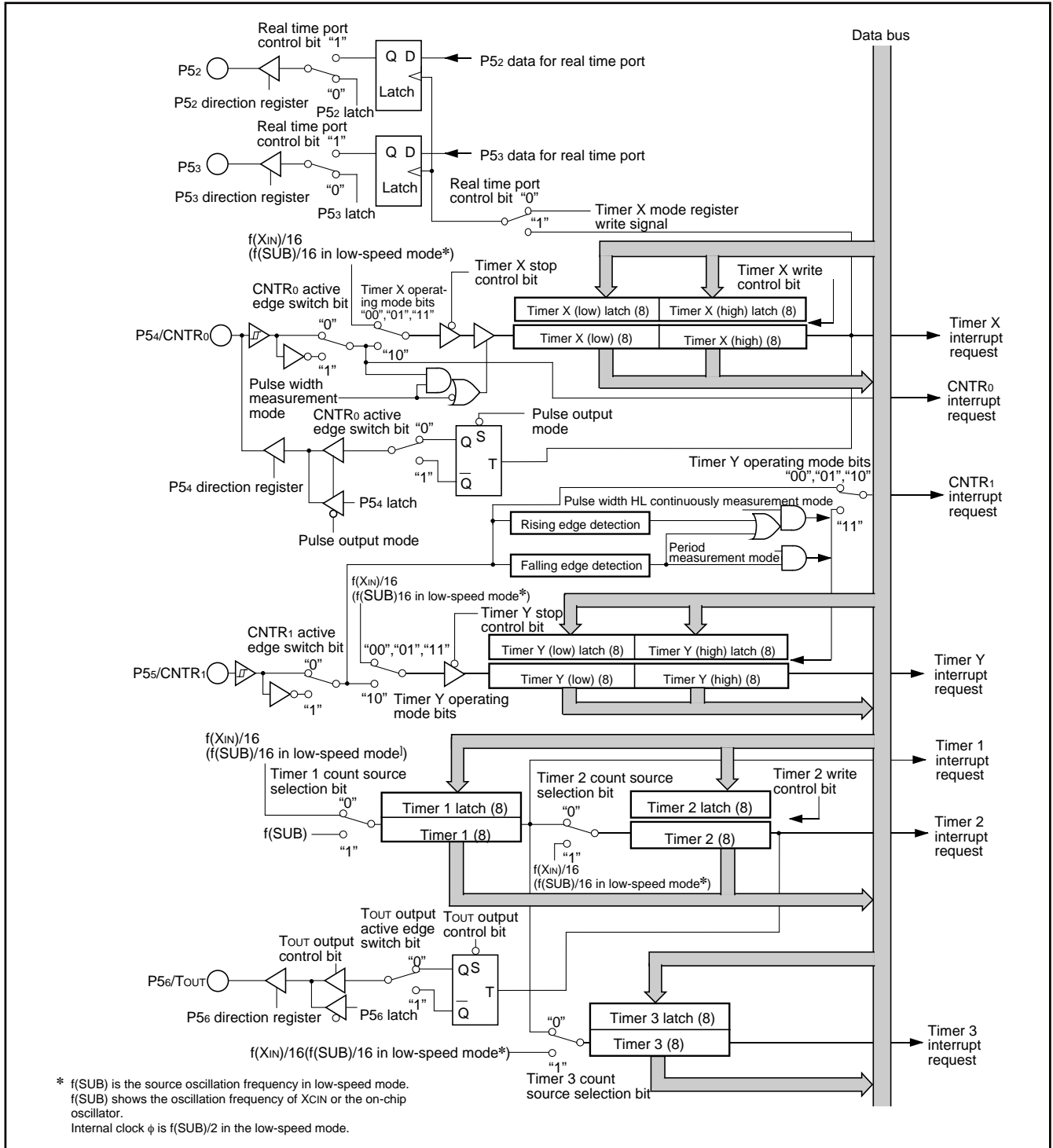

Fig. 22 Timer block diagram

Timer X

Timer X is a 16-bit timer that can be selected in one of four modes and can be controlled the timer X write and the real time port by setting the timer X mode register.

(1) Timer Mode

The timer counts $f(X_{IN})/16$ (or $f(SUB)/16$ in low-speed mode). $f(SUB)$ is the source oscillation frequency in low-speed mode. $f(SUB)$ shows the oscillation frequency of X_{CIN} or the on-chip oscillator. Internal clock ϕ is $f(X_{CIN})/2$ in the low-speed mode.

(2) Pulse Output Mode

Each time the timer underflows, a signal output from the $CNTR_0$ pin is inverted. Except for this, the operation in pulse output mode is the same as in timer mode. When using a timer in this mode, set the corresponding port P54 direction register to output mode.

(3) Event Counter Mode

The timer counts signals input through the $CNTR_0$ pin. Except for this, the operation in event counter mode is the same as in timer mode. When using a timer in this mode, set the corresponding port P54 direction register to input mode.

(4) Pulse Width Measurement Mode

The count source is $f(X_{IN})/16$ (or $f(SUB)/16$ in low-speed mode). If $CNTR_0$ active edge switch bit is "0", the timer counts while the input signal of $CNTR_0$ pin is at "H". If it is "1", the timer counts while the input signal of $CNTR_0$ pin is at "L". When using a timer in this mode, set the corresponding port P54 direction register to input mode.

●Timer X write control

If the timer X write control bit is "0", when the value is written in the address of timer X, the value is loaded in the timer X and the latch at the same time.

If the timer X write control bit is "1", when the value is written in the address of timer X, the value is loaded only in the latch. The value in the latch is loaded in timer X after timer X underflows.

If the value is written in latch only, when writing in the timer latch at the timer underflow, the value is set in the timer and the latch at one time. Additionally, unexpected value may be set in the high-order counter when the writing in high-order latch and the underflow of timer X are performed at the same timing.

●Real time port control

While the real time port function is valid, data for the real time port are output from ports P52 and P53 each time the timer X underflows. (However, after rewriting a data for real time port, if the real time port control bit is changed from "0" to "1", data are output independent of the timer X operation.) If the data for the real time port is changed while the real time port function is valid, the changed data are output at the next underflow of timer X. Before using this function, set the corresponding port direction registers to output mode.

■Note on $CNTR_0$ interrupt active edge selection

$CNTR_0$ interrupt active edge depends on the $CNTR_0$ active edge switch bit.

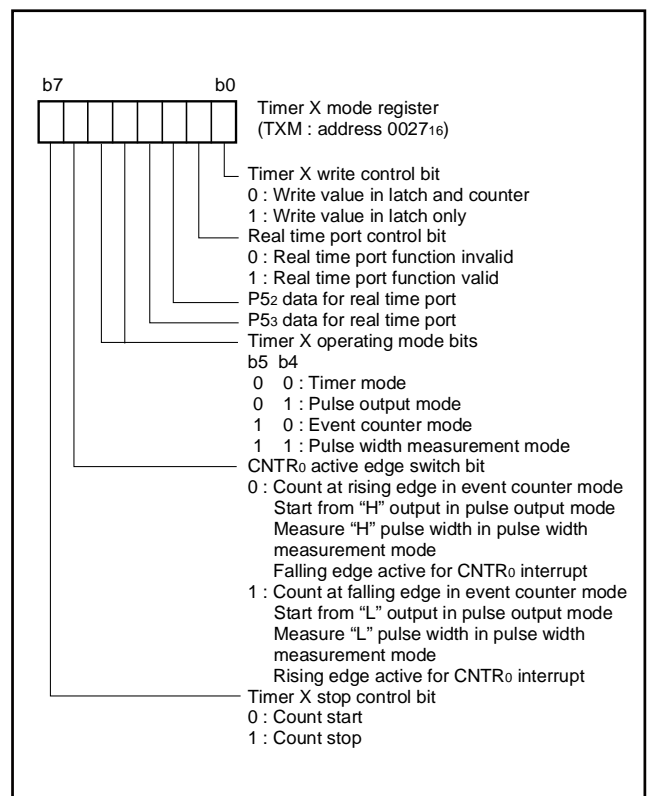

Fig. 23 Structure of timer X mode register

Timer Y

Timer Y is a 16-bit timer that can be selected in one of four modes.

(1) Timer Mode

The timer counts $f(XIN)/16$ (or $f(SUB)/16$ in low-speed mode).

(2) Period Measurement Mode

CNTR1 interrupt request is generated at rising/falling edge of CNTR1 pin input signal. Simultaneously, the value in timer Y latch is reloaded in timer Y and timer Y continues counting down. Except for the above-mentioned, the operation in period measurement mode is the same as in timer mode.

The timer value just before the reloading at rising/falling of CNTR1 pin input signal is retained until the timer Y is read once after the reload.

The rising/falling timing of CNTR1 pin input signal is found by CNTR1 interrupt. When using a timer in this mode, set the corresponding port P55 direction register to input mode.

(3) Event Counter Mode

The timer counts signals input through the CNTR1 pin.

Except for this, the operation in event counter mode is the same as in timer mode. When using a timer in this mode, set the corresponding port P55 direction register to input mode.

(4) Pulse Width HL Continuously Measurement Mode

CNTR1 interrupt request is generated at both rising and falling edges of CNTR1 pin input signal. Except for this, the operation in pulse width HL continuously measurement mode is the same as in period measurement mode. When using a timer in this mode, set the corresponding port P55 direction register to input mode.

■Note on CNTR1 interrupt active edge selection

CNTR1 interrupt active edge depends on the CNTR1 active edge switch bit. However, in pulse width HL continuously measurement mode, CNTR1 interrupt request is generated at both rising and falling edges of CNTR1 pin input signal regardless of the setting of CNTR1 active edge switch bit.

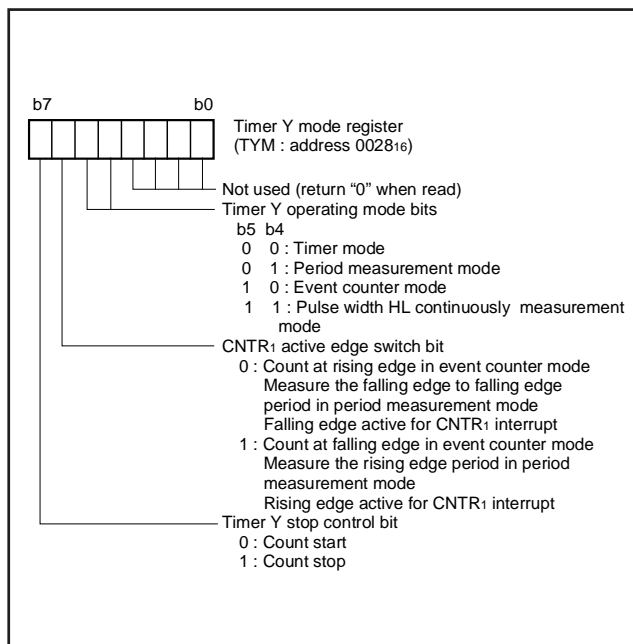

Fig. 24 Structure of timer Y mode register

Timer 1, Timer 2, Timer 3

Timer 1, timer 2, and timer 3 are 8-bit timers. The count source for each timer can be selected by timer 123 mode register. The timer latch value is not affected by a change of the count source. However, because changing the count source may cause an inadvertent count down of the timer, rewrite the value of timer whenever the count source is changed.

●Timer 2 write control

If the timer 2 write control bit is "0", when the value is written in the address of timer 2, the value is loaded in the timer 2 and the latch at the same time.

If the timer 2 write control bit is "1", when the value is written in the address of timer 2, the value is loaded only in the latch. The value in the latch is loaded in timer 2 after timer 2 underflows.

●Timer 2 output control

When the timer 2 (TOUT) is output enabled, an inversion signal from the TOUT pin is output each time timer 2 underflows.

In this case, set the port shared with the TOUT pin to the output mode.

■Notes on timer 1 to timer 3

When the count source of timer 1 to 3 is changed, the timer counting value may be changed large because a thin pulse is generated in count input of timer. If timer 1 output is selected as the count source of timer 2 or timer 3, when timer 1 is written, the counting value of timer 2 or timer 3 may be changed large because a thin pulse is generated in timer 1 output.

Therefore, set the value of timer in the order of timer 1, timer 2 and timer 3 after the count source selection of timer 1 to 3.

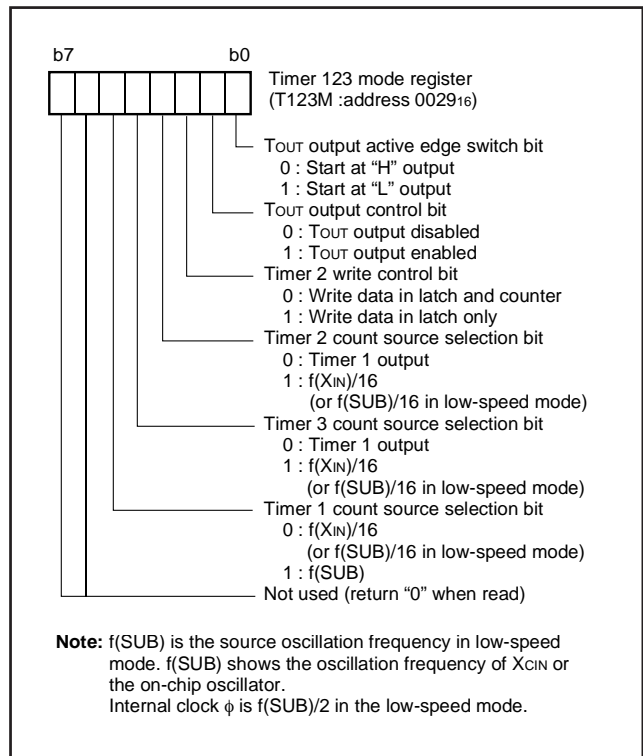

Fig. 25 Structure of timer 123 mode register

SERIAL INTERFACE Serial I/O

Serial I/O can be used as either clock synchronous or asynchronous (UART) serial I/O. A dedicated timer (baud rate generator) is also provided for baud rate generation.

(1) Clock Synchronous Serial I/O Mode

Clock synchronous serial I/O can be selected by setting the mode selection bit of the serial I/O control register to "1".

For clock synchronous serial I/O, the transmitter and the receiver must use the same clock. If an internal clock is used, transfer is started by a write signal to the transmit/receive buffer register.

The MSB first transfer is selected as the transfer direction by setting the bit 0 in the peripheral function expansion register to "1". Also, the synchronous serial I/O output switches to the P47/SRDY/SOUT pin by setting the bit 1 in the peripheral function expansion register to "1".

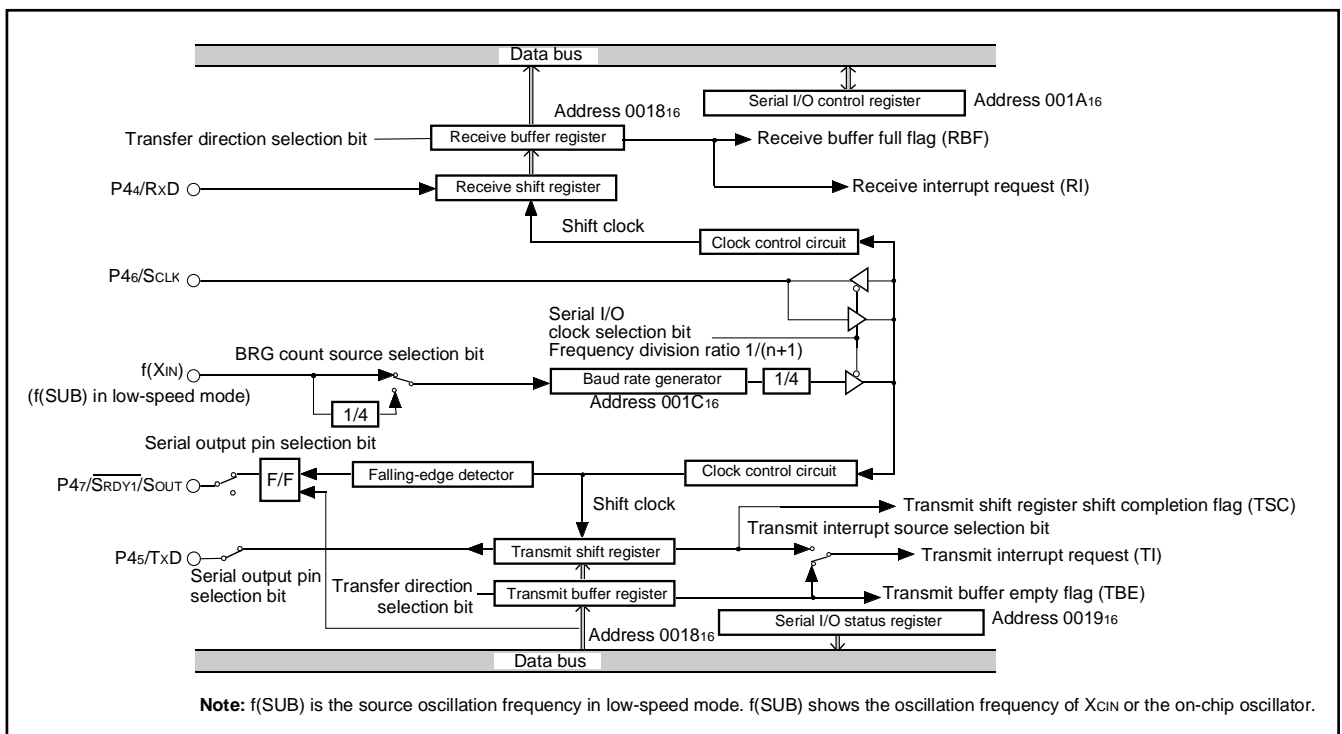

Fig. 26 Block diagram of clock synchronous serial I/O

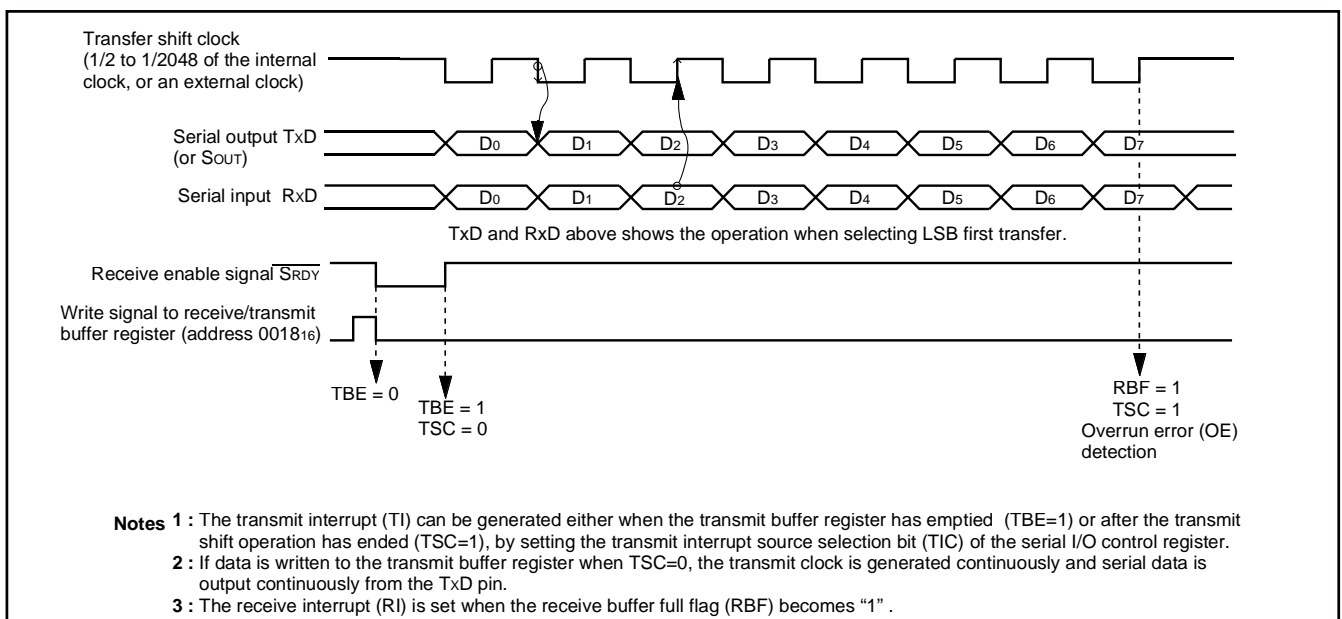

Fig. 27 Operation of clock synchronous serial I/O function

(2) Asynchronous Serial I/O (UART) Mode

Clock asynchronous serial I/O mode (UART) can be selected by clearing the serial I/O mode selection bit of the serial I/O control register to "0".

Eight serial data transfer formats can be selected, and the transfer formats used by a transmitter and receiver must be identical.

The transmit and receive shift registers each have a buffer regis-

ter, but the two buffers have the same address in memory. Since the shift register cannot be written to or read from directly, transmit data is written to the transmit buffer, and receive data is read from the receive buffer.

The transmit buffer can also hold the next data to be transmitted, and the receive buffer register can hold a character while the next character is being received.

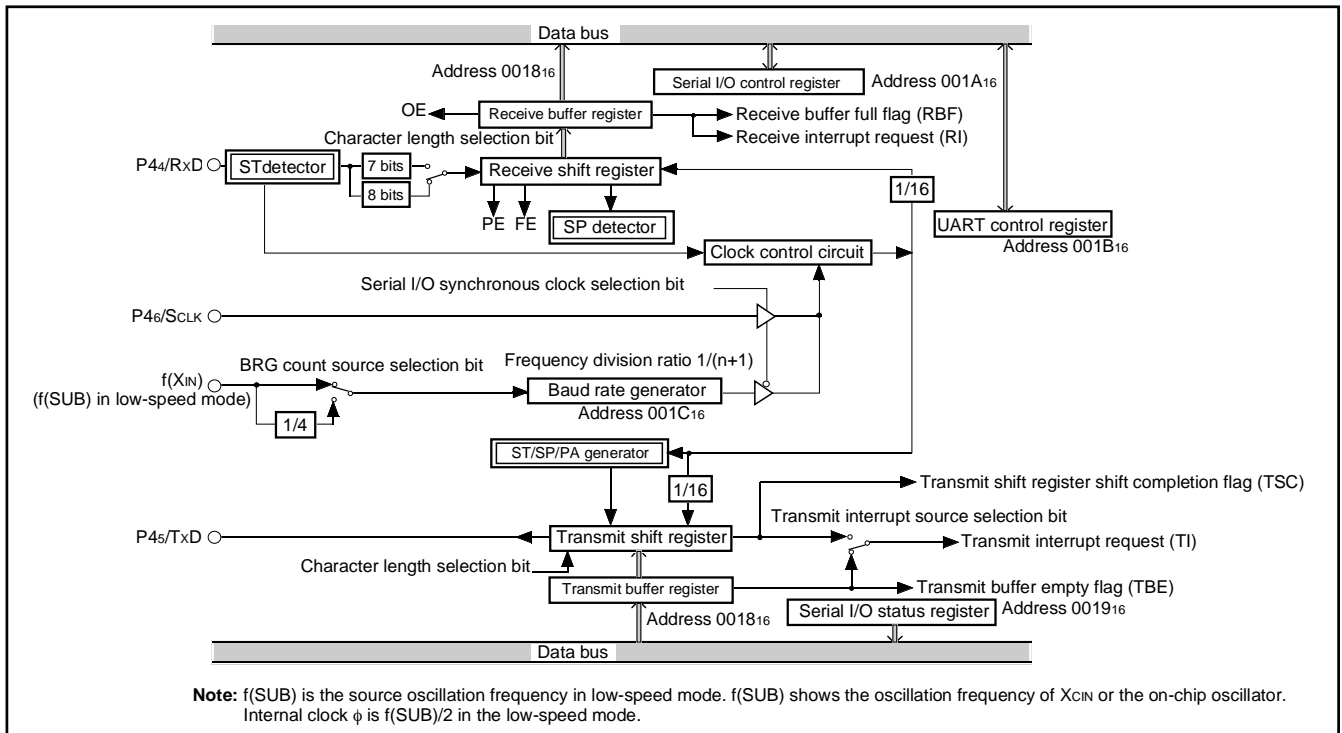

Fig. 28 Block diagram of UART serial I/O

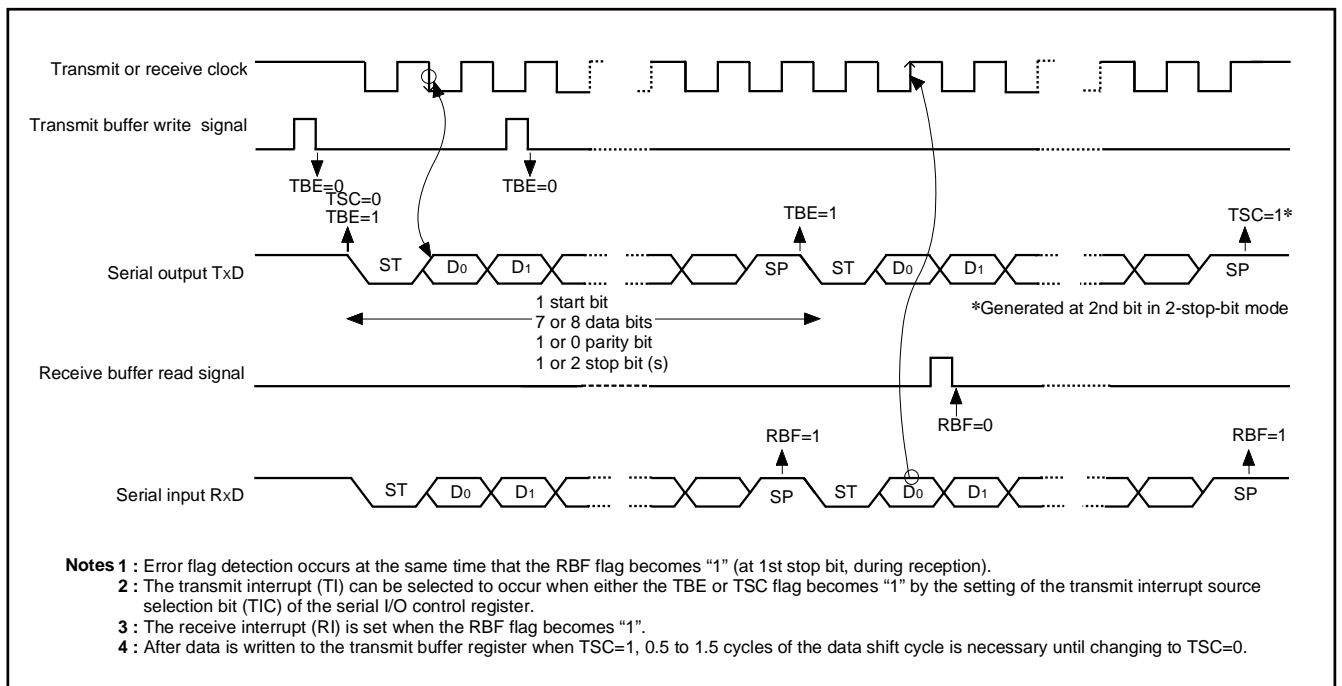

Fig. 29 Operation of UART serial I/O function

(3) Synchronous/Asynchronous Alternate Transmit Mode

Synchronous/asynchronous alternate transmit mode is selected by setting the transmit enable bit in the serial I/O control register to "1" after setting the synchronous serial I/O output pin selection bit in the peripheral function expansion register to "1". Set the synchronous serial I/O output pin selection bit to "1" when the serial I/O mode selection bit is set to "0". In this mode, transmit cannot be performed continuously. Write to the transmit buffer register after

confirming that the transmit shift register is set to "1", and then changing the serial I/O mode selection bit. The SRDY output function cannot be used when the clock synchronous serial I/O is selected. Also, when using the internal clock for the transfer clock (the serial I/O synchronous clock selection bit is set to "0"), apply "H" output to the P46 pin. The other operation is the same as clock synchronous serial I/O mode and asynchronous serial I/O mode (UART).

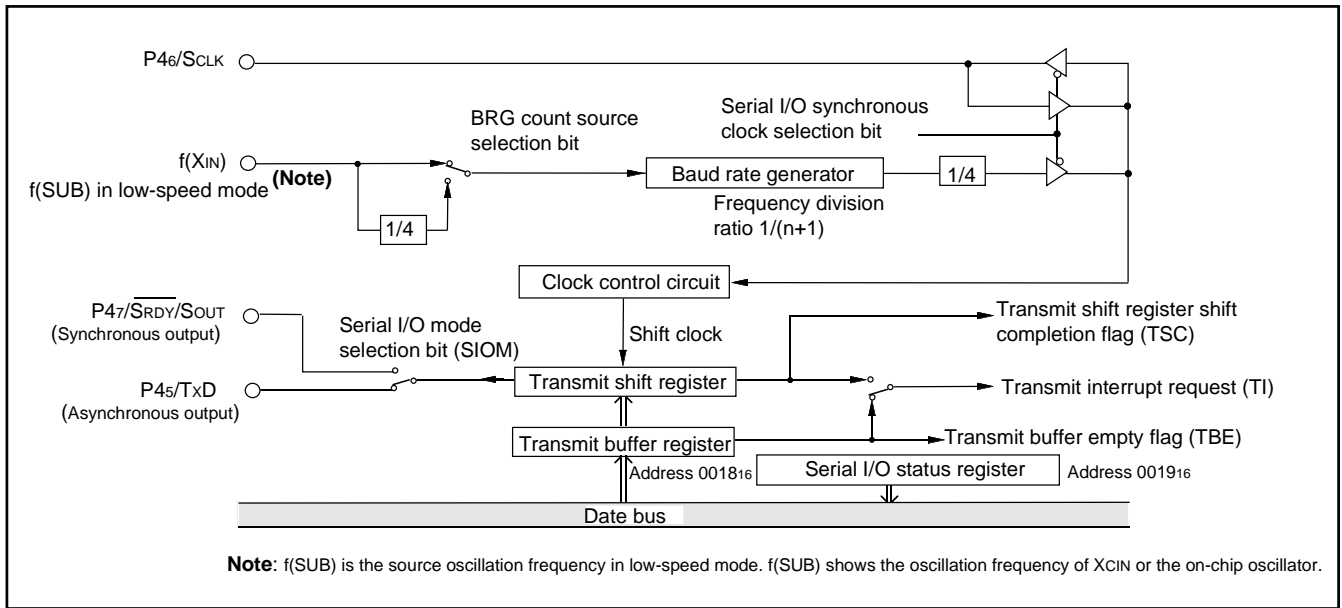

Fig. 30 Block diagram of synchronous/asynchronous alternate transmit

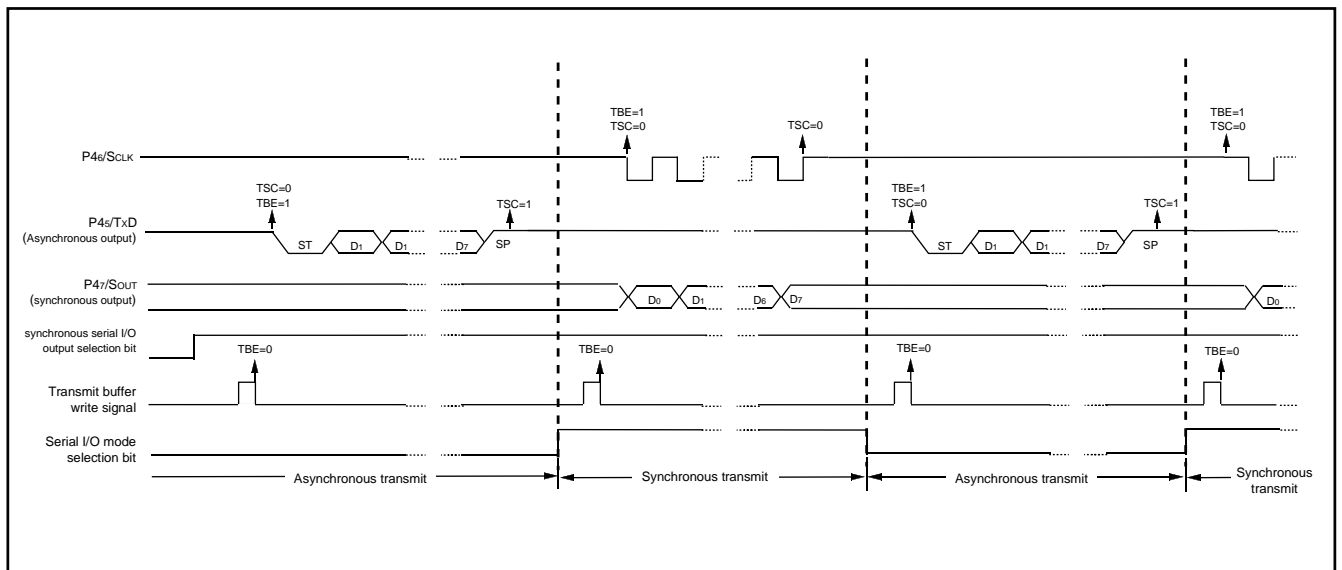

Fig. 31 Operation of synchronous/asynchronous alternate transmit function

[Transmit Buffer/Receive Buffer Register (TB/RB)] 001816

The transmit buffer register and the receive buffer register are located at the same address. The transmit buffer register is write-only and the receive buffer register is read-only. If a character bit length is 7 bits, the MSB of data stored in the receive buffer register is "0".

[Serial I/O Status Register (SIOSTS)] 001916

The read-only serial I/O status register consists of seven flags (bits 0 to 6) which indicate the operating status of the serial I/O function and various errors.

Three of the flags (bits 4 to 6) are valid only in UART mode.

The receive buffer full flag (bit 1) is cleared to "0" when the receive buffer is read.

If there is an error, it is detected at the same time that data is transferred from the receive shift register to the receive buffer register, and the receive buffer full flag is set. A write to the serial I/O status register clears all the error flags OE, PE, FE, and SE. Writing "0" to the serial I/O enable bit (SIOE) also clears all the status flags, including the error flags.

All bits of the serial I/O status register are initialized to "0" at reset, but if the transmit enable bit (bit 4) of the serial I/O control register has been set to "1", the transmit shift register shift completion flag (bit 2) and the transmit buffer empty flag (bit 0) become "1".

[Serial I/O Control Register (SIOCON)] 001A16

The serial I/O control register contains eight control bits for the serial I/O function.

[UART Control Register (UARTCON)] 001B16

The UART control register consists of four control bits (bits 0 to 3) which are valid when asynchronous serial I/O is selected and set the data format of an data transfer. One bit in this register (bit 4) is always valid and sets the output structure of the P45/TxD pin.

[Baud Rate Generator (BRG)] 001C16

The baud rate generator determines the baud rate for serial transfer.

The baud rate generator divides the frequency of the count source by $1/(n + 1)$, where n is the value written to the baud rate generator.

■Notes on serial I/O

When setting the transmit enable bit to "1", the serial I/O transmit interrupt request bit is automatically set to "1". When not requiring the interrupt occurrence synchronized with the transmission enabled, take the following sequence.

- ①Set the serial I/O transmit interrupt enable bit to "0" (disabled).
- ②Set the transmit enable bit to "1".
- ③Set the serial I/O transmit interrupt request bit to "0" after 1 or more instructions have been executed.
- ④Set the serial I/O transmit interrupt enable bit to "1" (enabled).

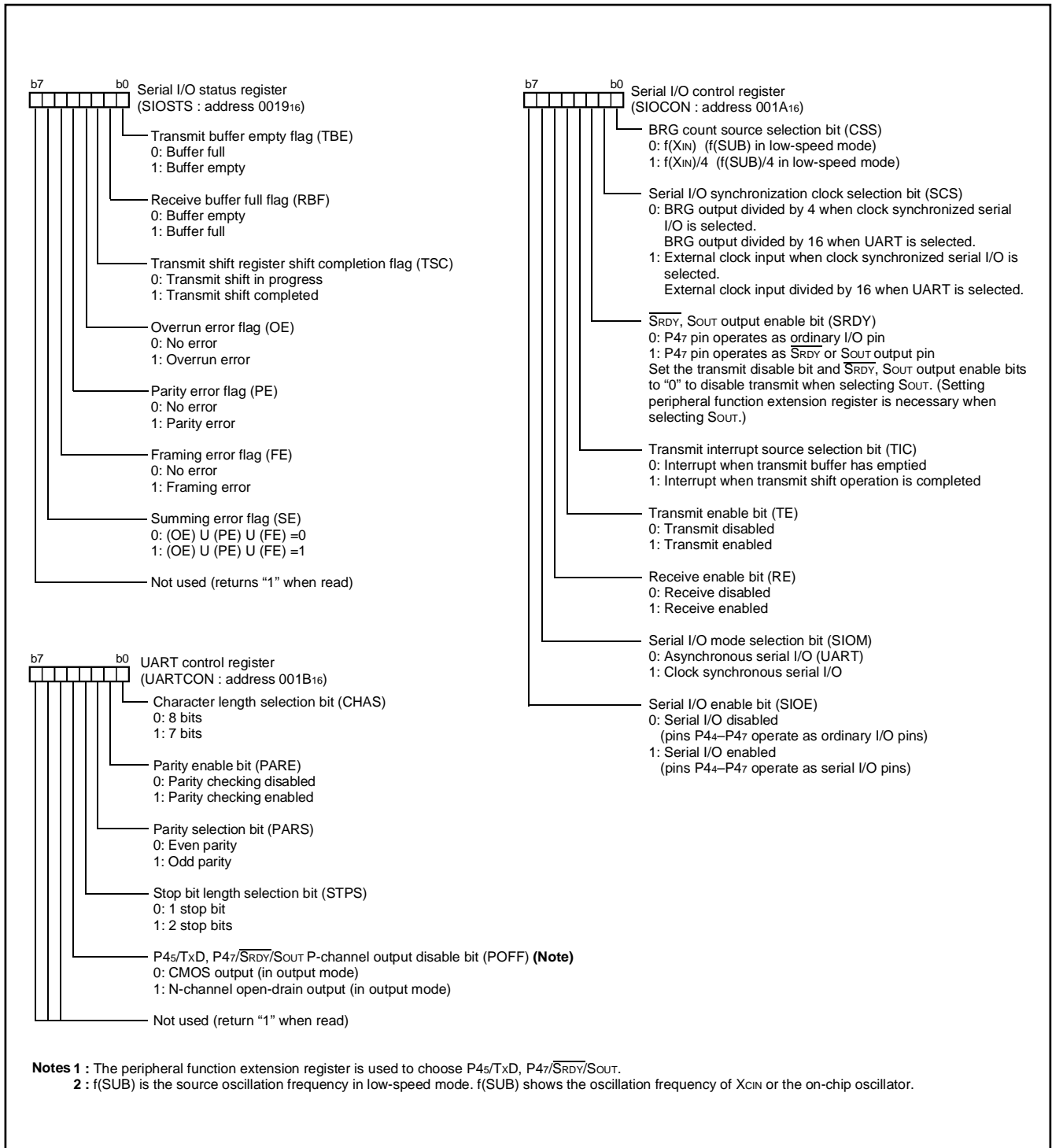

Fig. 32 Structure of serial I/O control registers

A/D CONVERTER

[AD Conversion Register (ADH, ADL)] 003516

The AD conversion register is a read-only register that contains the result of an A/D conversion. When reading this register during an A/D conversion, the previous conversion result is read. The high-order 8 bits of a conversion result is stored in the AD conversion high-order register (address 003516), and the low-order 2 bits of the same result are stored in bit 7 and bit 6 of the AD conversion low-order register (address 003616).

The bit 0 in the AD conversion low-order register is used as the conversion mode selection bit. 8-bit A/D mode is selected by setting this bit to "0" and 10-bit A/D mode is selected by setting it to "1".

[AD Control Register (ADCON)] 003416

The AD control register controls the A/D conversion process. Bits 0 to 2 of this register select specific analog input pins. Bit 3 signals the completion of an A/D conversion. The value of this bit remains at "0" during an A/D conversion, then changes to "1" when the A/D conversion is completed. Writing "0" to this bit starts the A/D conversion. Bit 4 is the VREF input switch bit which controls connection of the resistor ladder and the reference voltage input pin (VREF). The resistor ladder is always connected to VREF when bit 4 is set to "1". When bit 4 is set to "0", the resistor ladder is cut off from VREF except for A/D conversion performed. When bit 5, which is the AD external trigger valid bit, is set to "1", this bit enables A/D conversion even by a falling edge of an ADT input. Set the P57/ADT pin to input mode (set "0" to bit 7 of port P5 direction register) when using an A/D external trigger.

[Comparison Voltage Generator]

The comparison voltage generator divides the voltage between AVSS and VREF, and outputs the divided voltages.

[Channel Selector]

The channel selector selects one of the input ports P67/AN7–P60/AN0, and inputs it to the comparator.

[Comparator and Control Circuit]

The comparator and control circuit compares an analog input voltage with the comparison voltage and stores the result in the AD conversion register. When an A/D conversion is completed, the control circuit sets the AD conversion completion bit and the AD interrupt request bit to "1".

The comparator is constructed linked to a capacitor. The conversion accuracy may be low because the charge is lost if the conversion speed is not enough. Accordingly, set f(XIN) to at least 500kHz during A/D conversion in the middle-or high-speed mode. Also, do not execute the STP or WIT instruction during an A/D conversion.

In the low-speed mode, since the A/D conversion is executed by the built-in self-oscillation circuit, the minimum value of f(XIN) frequency is not limited.

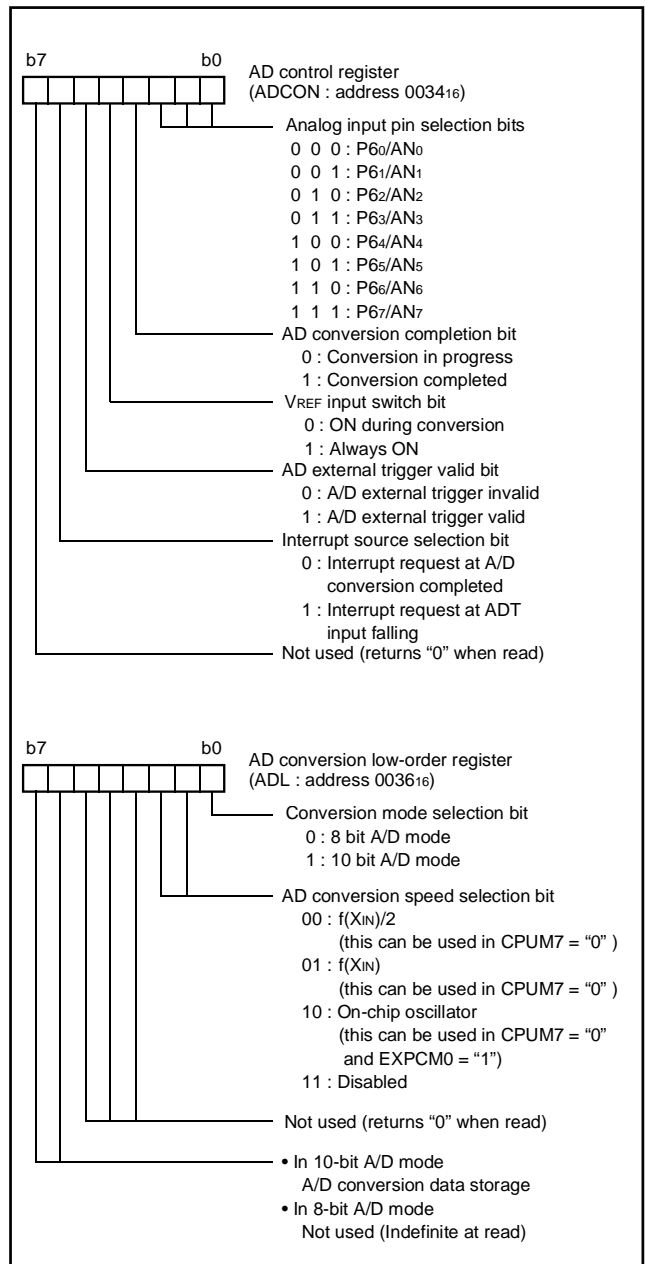

Fig. 33 Structure of AD conversion-related registers

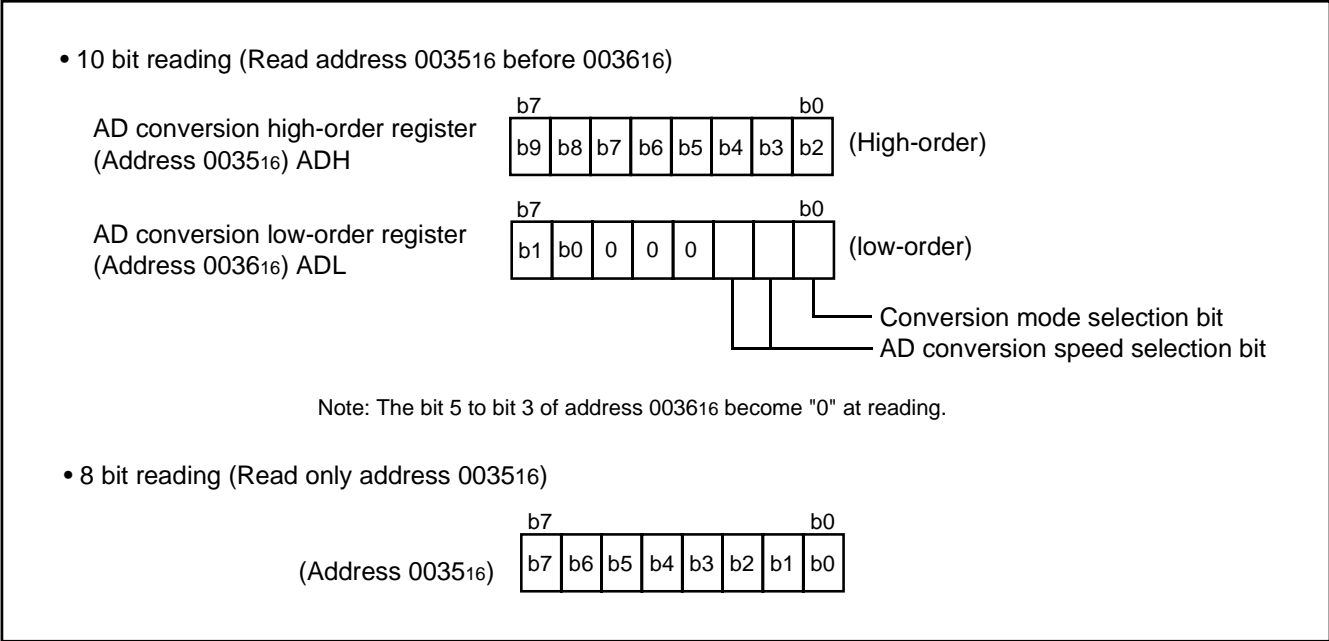

Fig. 34 A/D conversion register reading

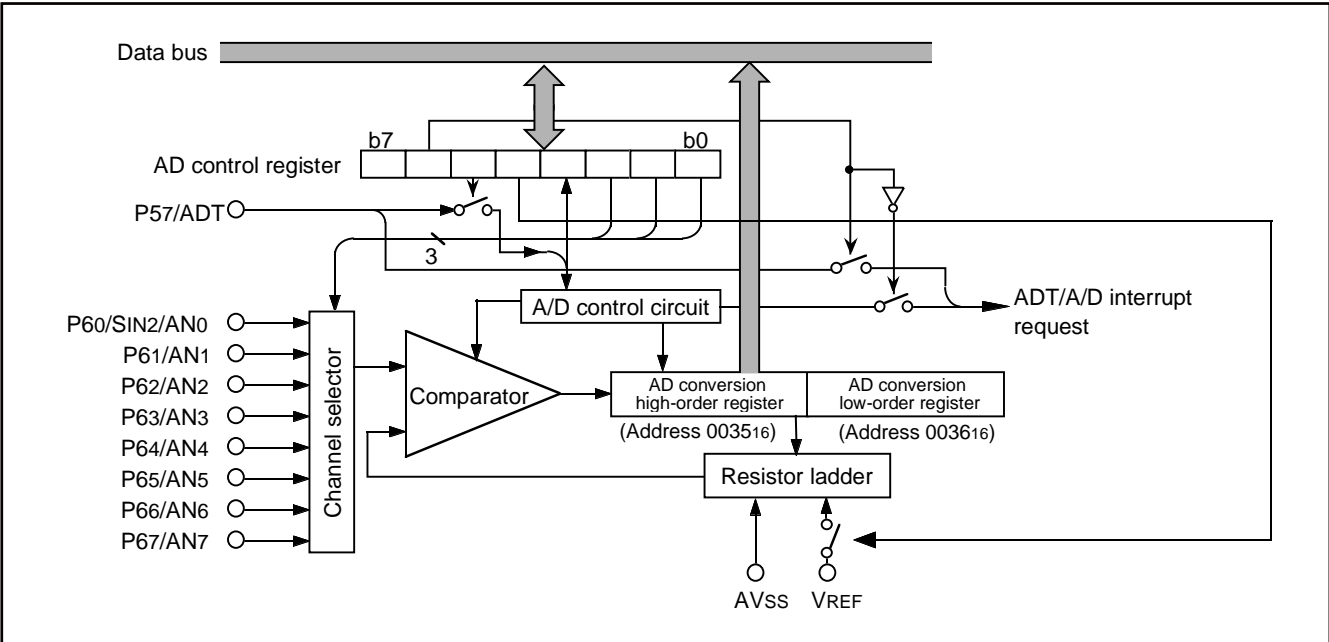

Fig. 35 A/D converter block diagram

LCD DRIVE CONTROL CIRCUIT

The 3823 group has the built-in Liquid Crystal Display (LCD) drive control circuit consisting of the following.

- LCD display RAM
- Segment output enable register
- LCD mode register
- Selector
- Timing controller
- Common driver
- Segment driver
- Bias control circuit

A maximum of 32 segment output pins and 4 common output pins can be used.

Up to 128 pixels can be controlled for LCD display. When the LCD

enable bit is set to "1" after data is set in the LCD mode register, the segment output enable register and the LCD display RAM, the LCD drive control circuit starts reading the display data automatically, performs the bias control and the duty ratio control, and displays the data on the LCD panel.

Table 10 Maximum number of display pixels at each duty ratio

Duty ratio	Maximum number of display pixel
2	64 dots or 8 segment LCD 8 digits
3	96 dots or 8 segment LCD 12 digits
4	128 dots or 8 segment LCD 16 digits

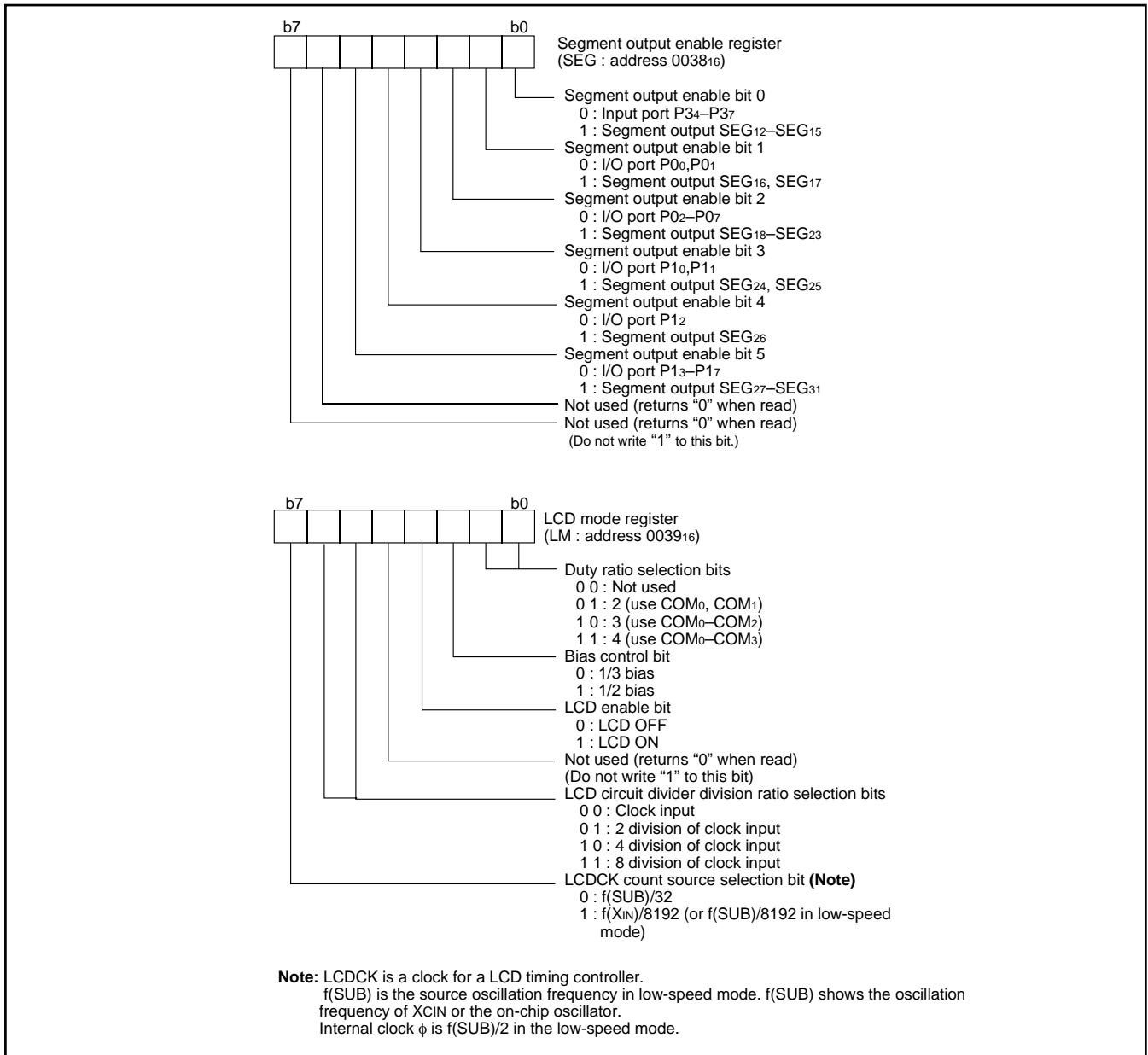

Fig. 36 Structure of segment output enable register and LCD mode register

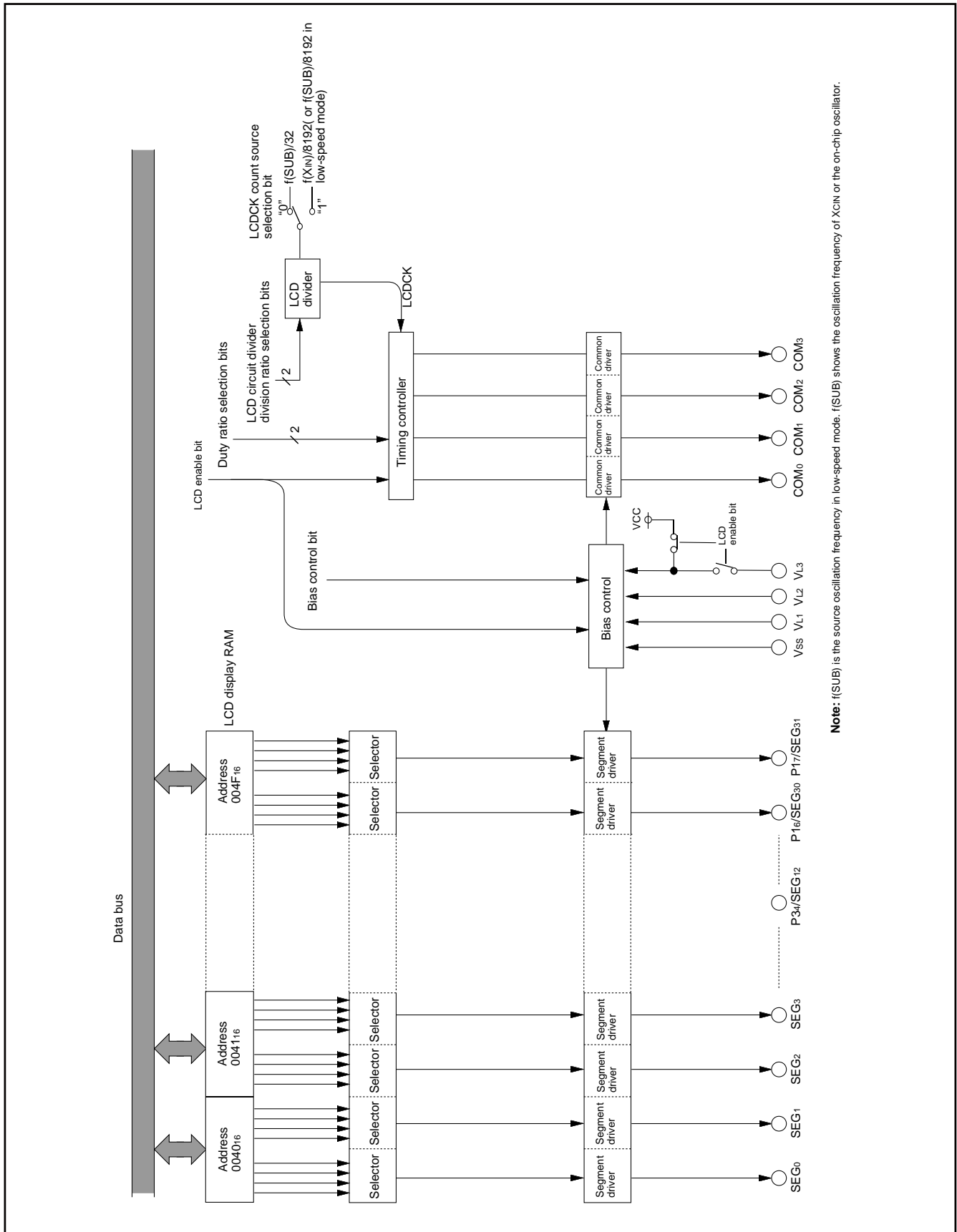

Fig. 37 Block diagram of LCD controller/driver

Bias Control and Applied Voltage to LCD Power Input Pins

To the LCD power input pins (VL1–VL3), apply the voltage shown in Table 11 according to the bias value.

Select a bias value by the bias control bit (bit 2 of the LCD mode register).

Common Pin and Duty Ratio Control

The common pins (COM0–COM3) to be used are determined by duty ratio.

Select duty ratio by the duty ratio selection bits (bits 0 and 1 of the LCD mode register).

Table 11 Bias control and applied voltage to VL1–VL3

Bias value	Voltage value
1/3 bias	VL3=VLCD
	VL2=2/3 VLCD
	VL1=1/3 VLCD
1/2 bias	VL3=VLCD
	VL2=VL1=1/2 VLCD

Note 1: VLCD is the maximum value of supplied voltage for the LCD panel.

Table 12 Duty ratio control and common pins used

Duty ratio	Duty ratio selection bit		Common pins used
	Bit 1	Bit 0	
2	0	1	COM0, COM1 (Note 1)
3	1	0	COM0–COM2 (Note 2)
4	1	1	COM0–COM3

Notes1: COM2 and COM3 are open.

2: COM3 is open.

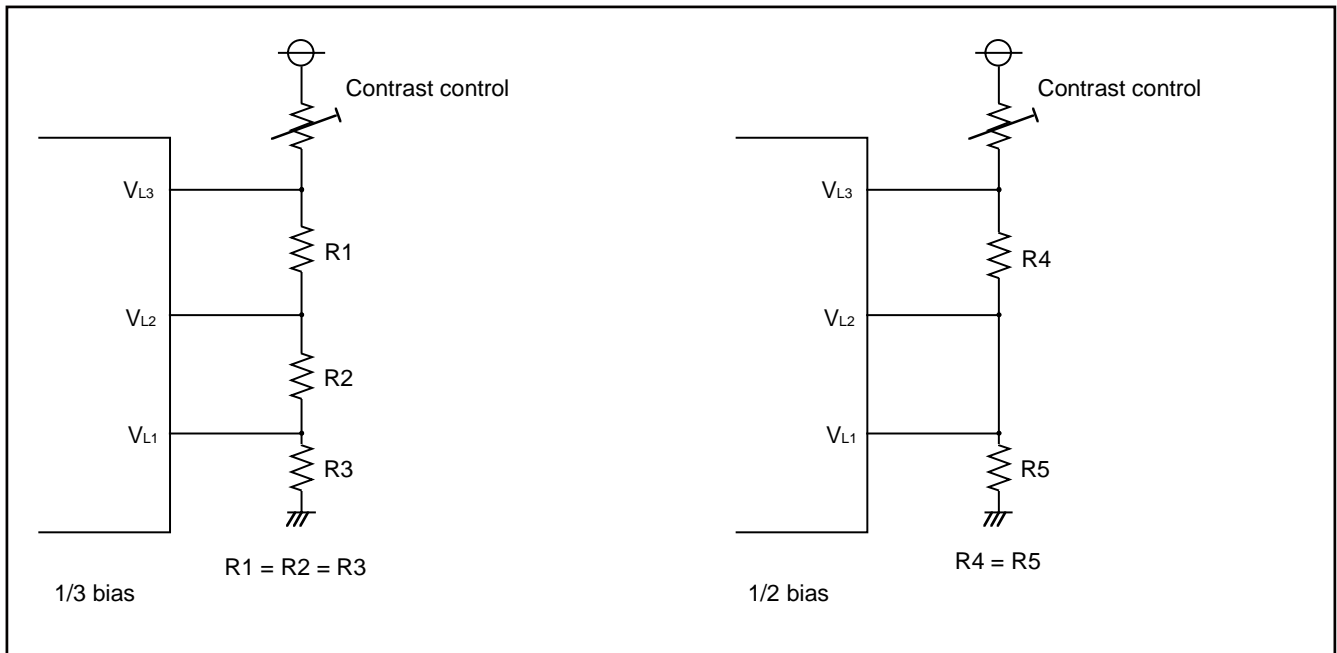

Fig. 38 Example of circuit at each bias

LCD Display RAM

Address 0040₁₆ to 004F₁₆ is the designated RAM for the LCD display. When "1" are written to these addresses, the corresponding segments of the LCD display panel are turned on.

LCD Drive Timing

The LCDCK timing frequency (LCD drive timing) is generated internally and the frame frequency can be determined with the following equation;

$$f(\text{LCDCK}) = \frac{\text{(frequency of count source for LCDCK)}}{\text{(divider division ratio for LCD)}}$$

$$\text{Frame frequency} = \frac{f(\text{LCDCK})}{\text{(duty ratio)}}$$

Bit Address	7	6	5	4	3	2	1	0
0040 ₁₆	SEG1				SEG0			
0041 ₁₆	SEG3				SEG2			
0042 ₁₆	SEG5				SEG4			
0043 ₁₆	SEG7				SEG6			
0044 ₁₆	SEG9				SEG8			
0045 ₁₆	SEG11				SEG10			
0046 ₁₆	SEG13				SEG12			
0047 ₁₆	SEG15				SEG14			
0048 ₁₆	SEG17				SEG16			
0049 ₁₆	SEG19				SEG18			
004A ₁₆	SEG21				SEG20			
004B ₁₆	SEG23				SEG22			
004C ₁₆	SEG25				SEG24			
004D ₁₆	SEG27				SEG26			
004E ₁₆	SEG29				SEG28			
004F ₁₆	SEG31				SEG30			
	COM3	COM2	COM1	COM0	COM3	COM2	COM1	COM0

Fig. 39 LCD display RAM map

STP Instruction Execution

Execution of the STP instruction sets the LCD enable bit (bit 3 of the LCD mode register) to "0" and the LCD panel turns off. To make the LCD panel turn on after returning from the stop mode, set the LCD enable bit to "1".

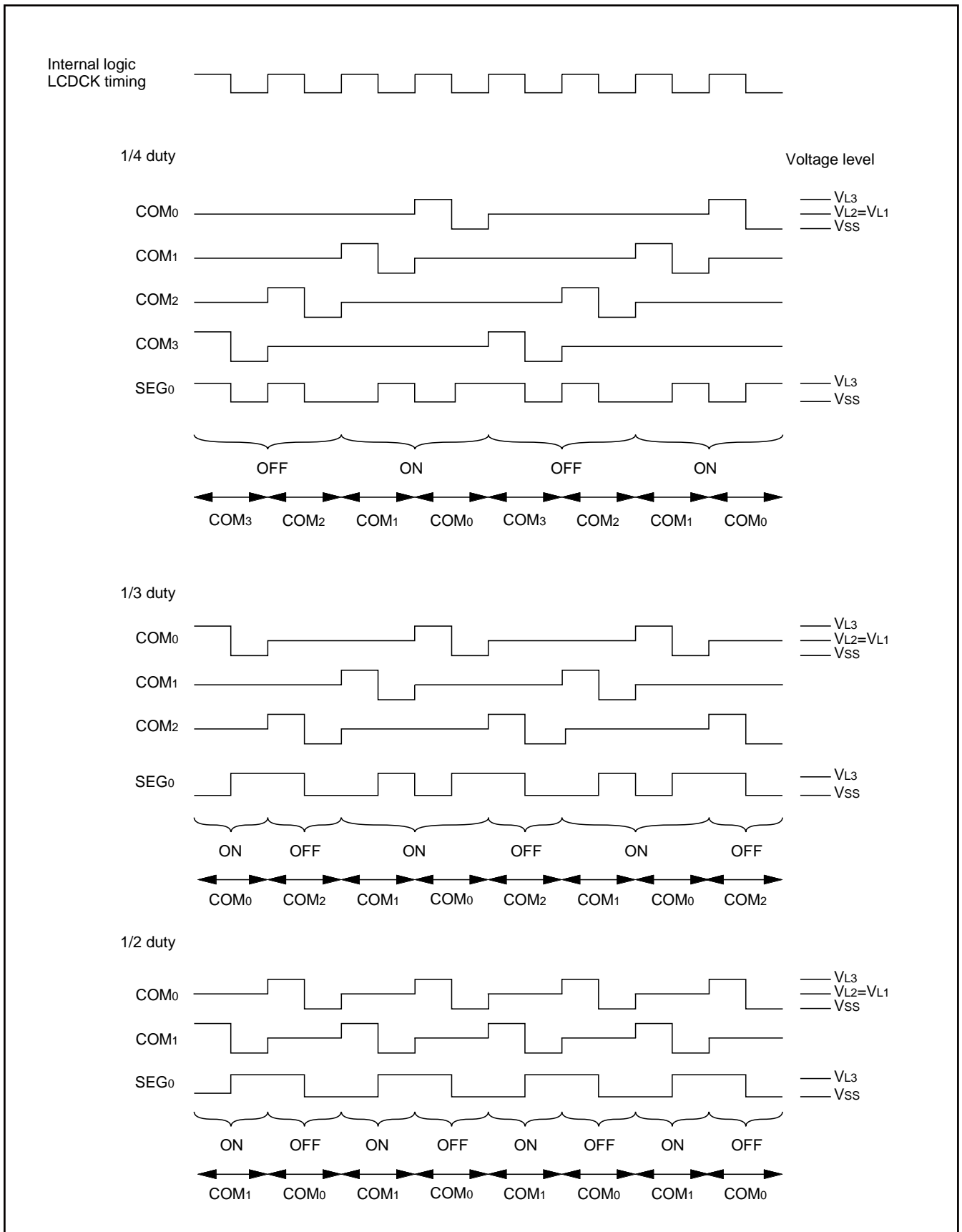

Fig. 40 LCD drive waveform (1/2 bias)

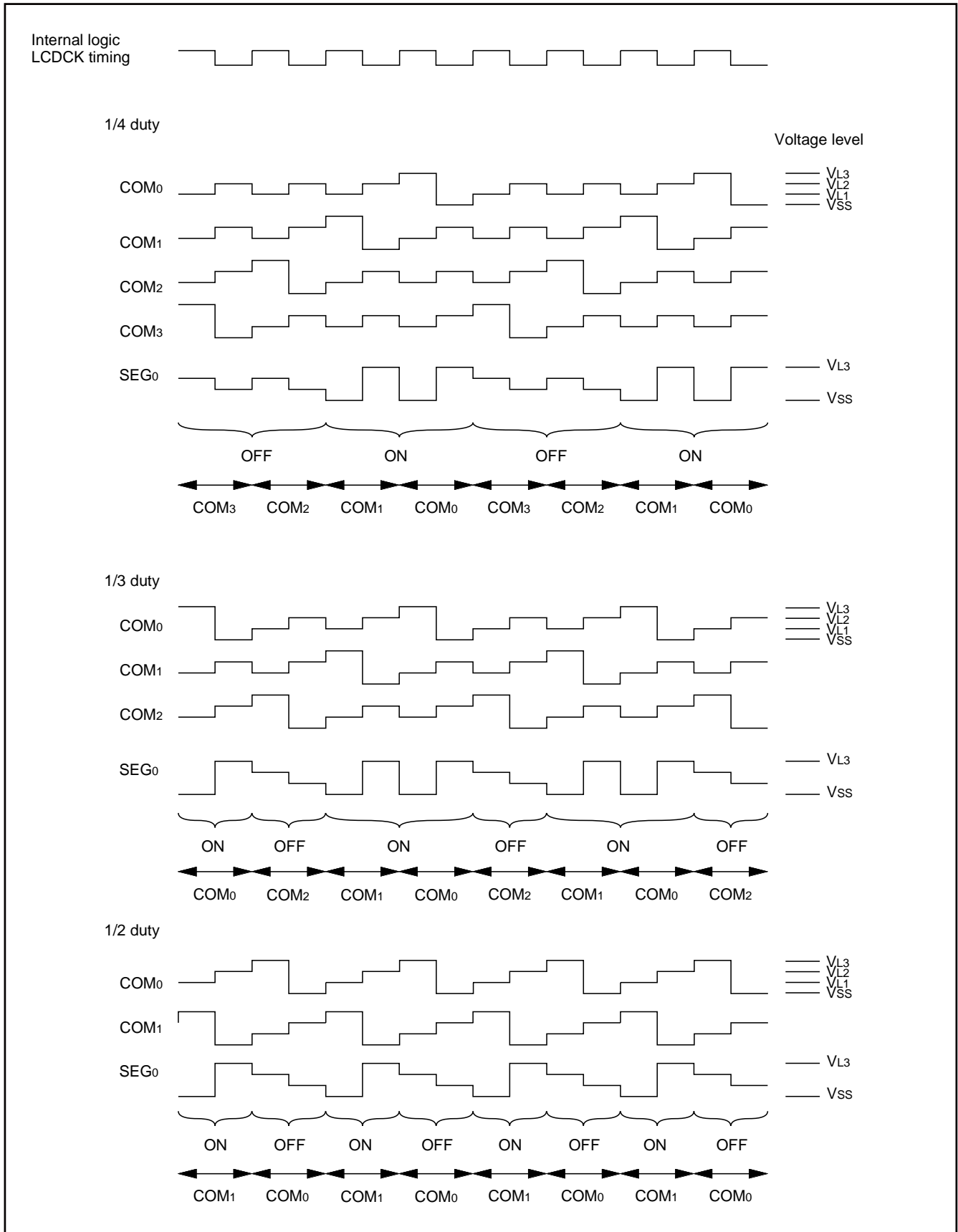

Fig. 41 LCD drive waveform (1/3 bias)

ROM CORRECTION FUNCTION

A part of program in ROM can be corrected.
 Set the start address of the corrected ROM data (i.e. an Op code address of the beginning instruction) to the ROM correction address low-order and high-order registers. The program for the correction is stored in RAM for ROM correction.
 When the program is being executed and the value of the program counter matches with the set address value in the the ROM correction address registers, the program is branched to the start address of RAM for ROM correction and then the correction program is executed. Use the JMP instruction (3-byte instruction) to return the main program from the correction program.
 The correctable area is up to two. There are two blocks of RAM for ROM correction:

- Block 1: Address 0A00₁₆
- Block 2: Address 0A20₁₆

The ROM correction function is controlled by the ROM correction enable register.
 If the ROM correction function is not used, the ROM correction vector may be used as normal RAM. When using the ROM correction vector as normal RAM, make sure to set bits 1 and 0 in the ROM correction enable register to "0" (Disable).

- Notes 1:** When using the ROM correction function, set the ROM correction address registers and then enable the ROM correction with the ROM correction enable register.
- 2:** Do not set addresses other than the ROM area in the ROM correction address registers.
 Do not set the same addresses in both the ROM correction address 1 registers and the ROM correction address 2 registers.
- 3:** It is necessary to contain the process in the program to transfer the correction program from an external EEPROM and others to the RAM for ROM correction.

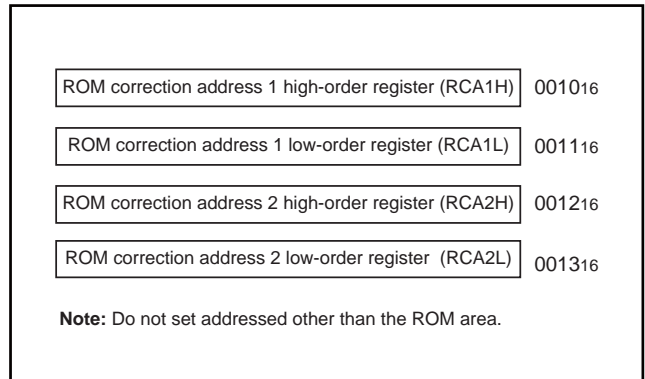

Fig. 42 ROM correction address register

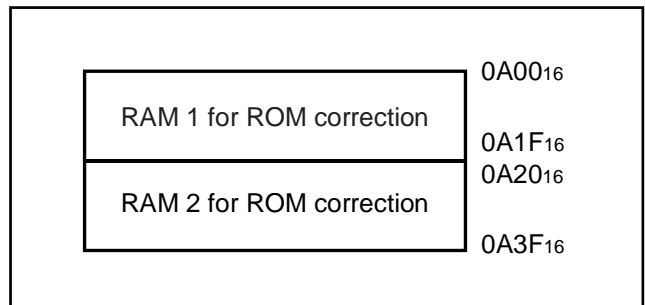

Fig. 43 RAM for ROM correction

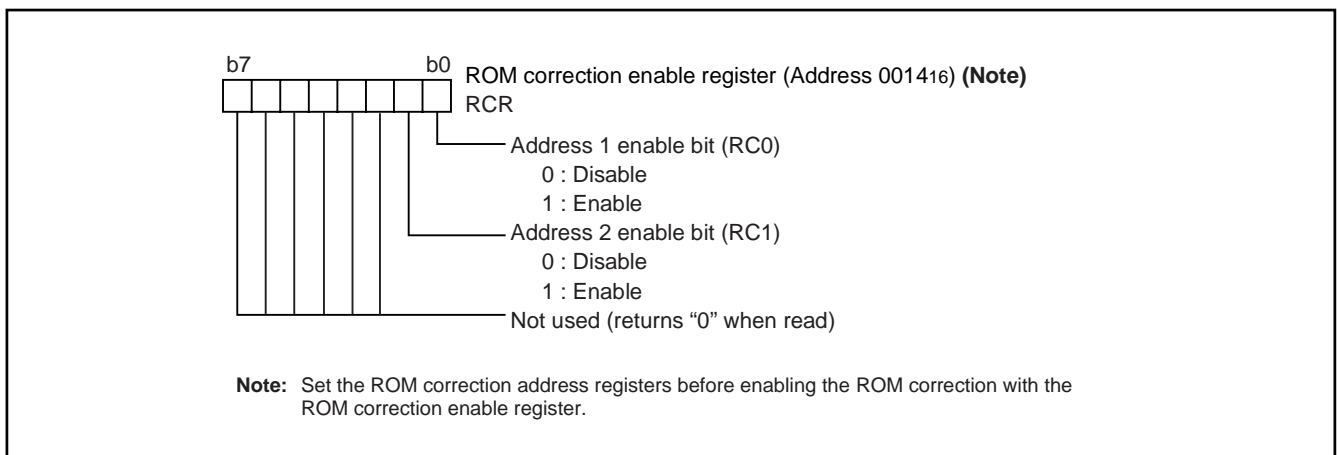

Fig. 44 Structure of ROM correction enable register

φ CLOCK SYSTEM OUTPUT FUNCTION

The internal system clock φ or XCIN frequency signal can be output from port P41 by setting the φ output control register. Set bit 1 of the port P4 direction register to "1" when outputting φ clock.

Set the bit 4 in the peripheral function expansion register to "1" when the XCIN frequency signal is output.

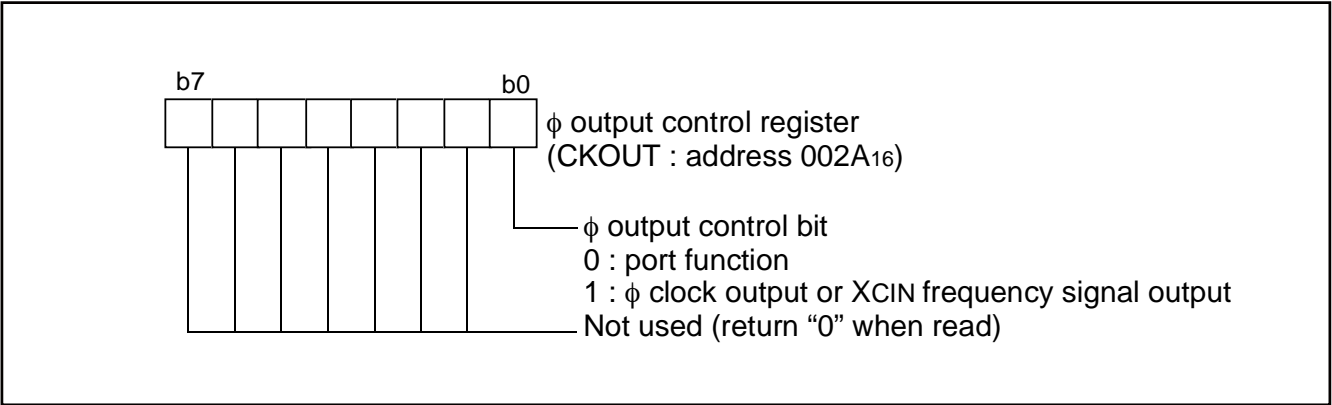

Fig. 45 Structure of φ output control register

Temporary data register

The temporary data register (addresses 002C16 to 002E16) is the 8-bit register and does not have the control function. It can be used to store data temporarily. It is initialized after reset.

RRF register

The RRF register (address 002F16) is the 8-bit register and does not have the control function. As for the value written in this register, high-order 4 bits and low-order 4 bits interchange. It is initialized after reset.

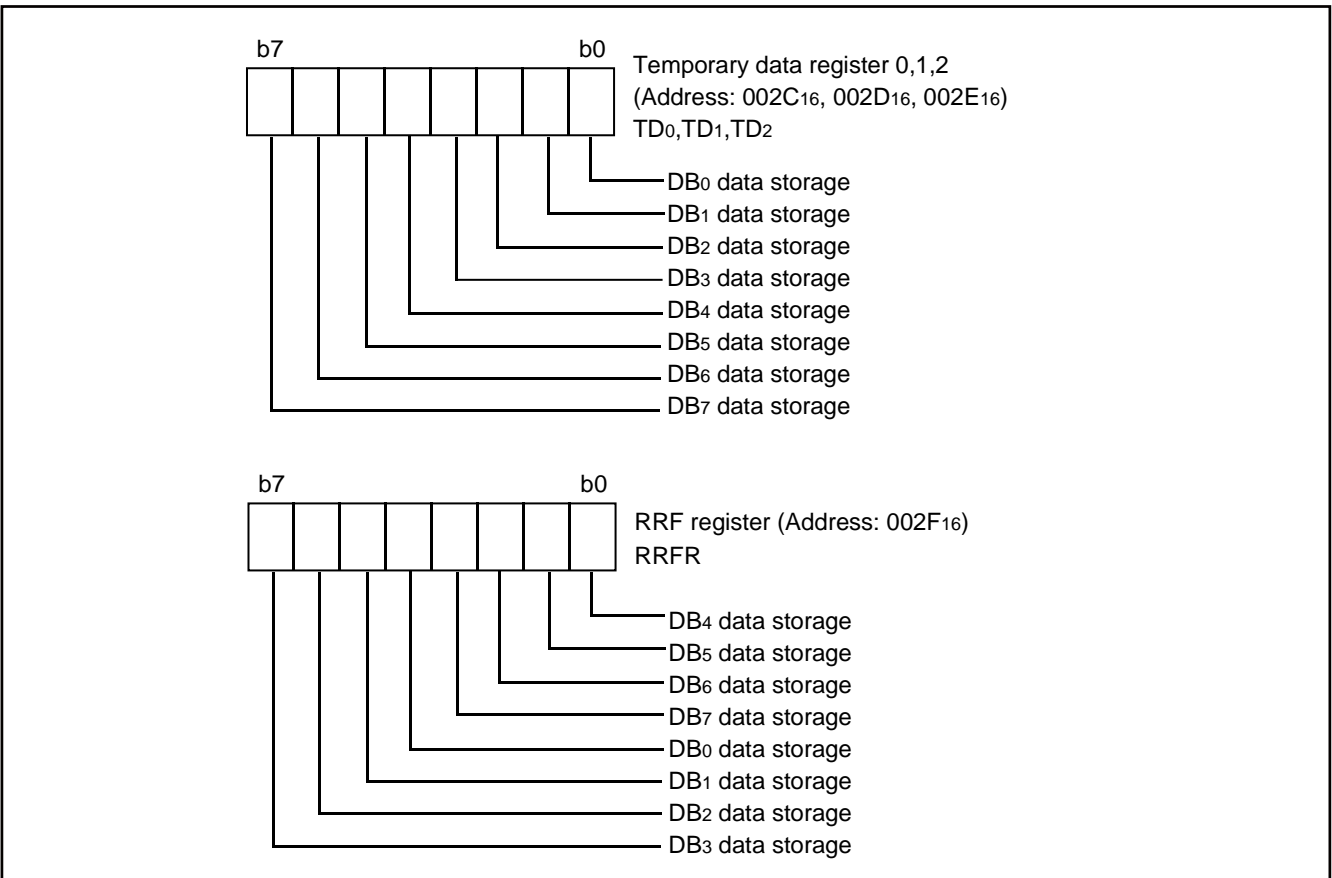

Fig. 46 Structure of temporary register, RPF register

WATCHDOG TIMER

The watchdog timer gives a mean of returning to the reset status when a program cannot run on a normal loop (for example, because of a software run-away). The watchdog timer consists of an 8-bit counter.

Initial Value of Watchdog Timer

At reset or writing to the watchdog timer control register, each watchdog timer is set to "FF16." Instructions such as STA, LDM and CLB to generate the write signals can be used. The written data in bits 0 to 5 are not valid, and the above values are set. Bits 7 and 6 can be rewritten only once after reset. After rewriting it is disable to write any data to this bit. These bits become "0" after reset.

Standard Operation of Watchdog Timer

The watchdog timer is in the stop state at reset and the watchdog timer starts to count down by writing an optional value in the watchdog timer control register. An internal reset occurs at an underflow of the watchdog timer. Then, reset is released after the reset release time is elapsed, the program starts from the reset vector address. Normally, writing to the watchdog timer control register before an underflow of the watchdog timer is programmed. If writing to the watchdog timer control register is not

executed, the watchdog timer does not operate. When reading the watchdog timer control register is executed, the contents of the high-order 6-bit counter and the STP instruction bit (bit 6), and the count source selection bit (bit 7) are read out.

Bit 6 of Watchdog Timer Control Register

- When bit 6 of the watchdog timer control register is "0", the MCU enters the stop mode by execution of STP instruction. Just after releasing the stop mode, the watchdog timer restarts counting (Note). When executing the WIT instruction, the watchdog timer does not stop.
- When bit 6 is "1", execution of STP instruction causes an internal reset. When this bit is set to "1" once, it cannot be rewritten to "0" by program. Bit 6 is "0" at reset.

The time until the underflow of the watchdog timer register after writing to the watchdog timer control register is executed is as follows (when the bit 7 of the watchdog timer control register is "0") ;

- at frequency/2/4/8 mode ($f(XIN) = 8\text{ MHz}$): 32.768 ms
- at low-speed mode ($f(XCIN) = 32\text{ KHz}$): 8.19s

■ Note

The watchdog timer continues to count even during the wait time set by timer 1 and timer 2 to release the stop state and in the wait mode. Accordingly, do not underflow the watchdog timer in this time.

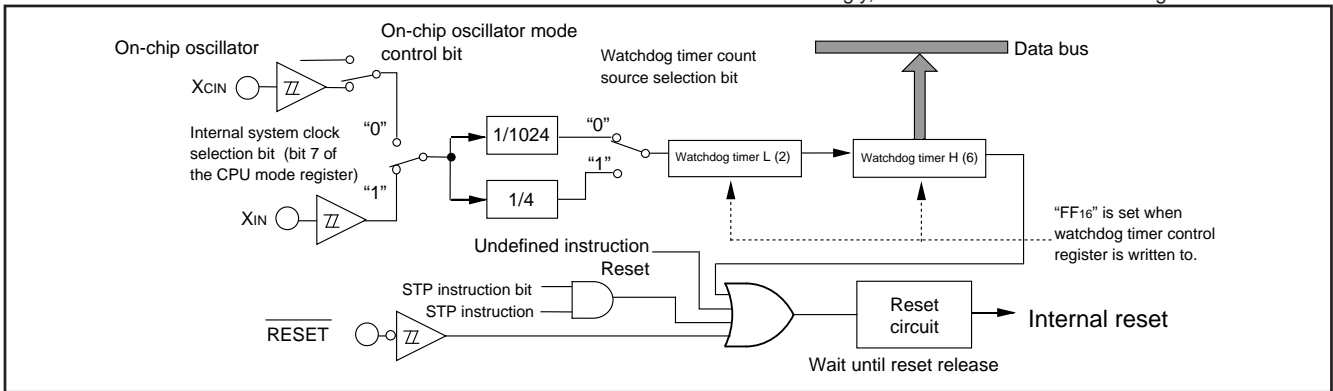

Fig. 47 Block diagram of Watchdog timer

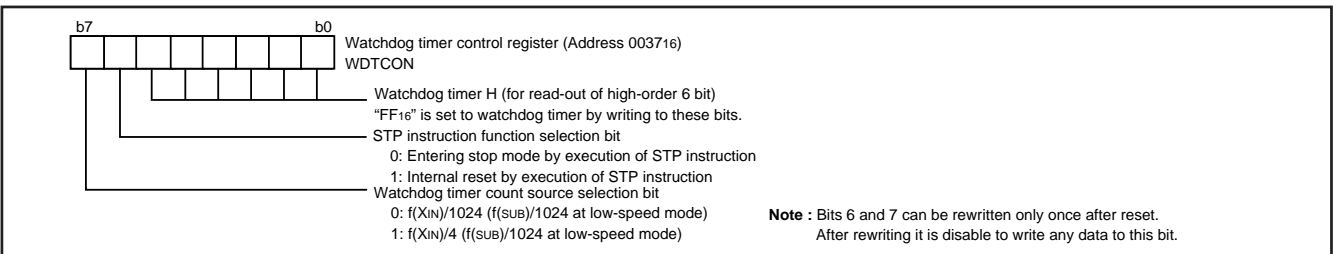

Fig. 48 Structure of Watchdog timer control register

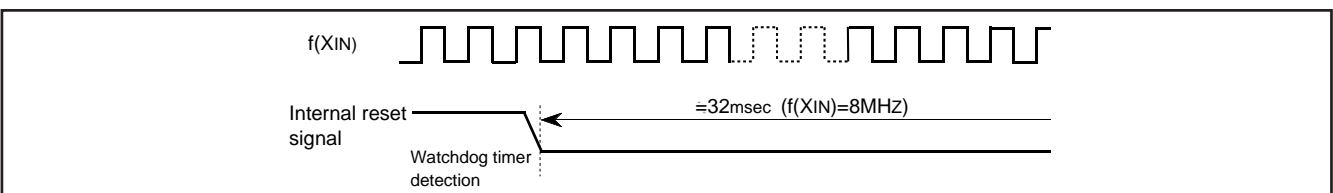

Fig. 49 Timing of reset output

PERIPHERAL FUNCTION EXTENSION REGISTER

The serial I/O transfer direction can be switched by setting the bit 0 in the peripheral function expansion register to "1". This function is valid only when the bit 6 in the serial I/O control register is set to "1" (when the clock synchronous serial I/O is selected). P47 can be selected as the output pin of the clock synchronous serial I/O by setting the bit 1 in the peripheral function expansion register to "1". When setting P47 to the SOUT pin, set the bit 7 in the port P4 direction register to "1". This function is valid only when the bit 6 in the serial I/O control register to "1" (when the clock synchronous serial I/O is selected). P-channel output of TXD and SOUT can be disabled by the bits 2 and 3 in the peripheral function expansion register. Set the bit 4 in the UART control register to "1" after selecting the pin to disable the P-channel output. XCIN frequency signal can be output from the port P41 by setting the bit 4 in the peripheral function expansion register to "1". Set the bit 0 in the ϕ output control register and the bit 1 in the port P4 direction register to "1" to output the XCIN frequency signal.

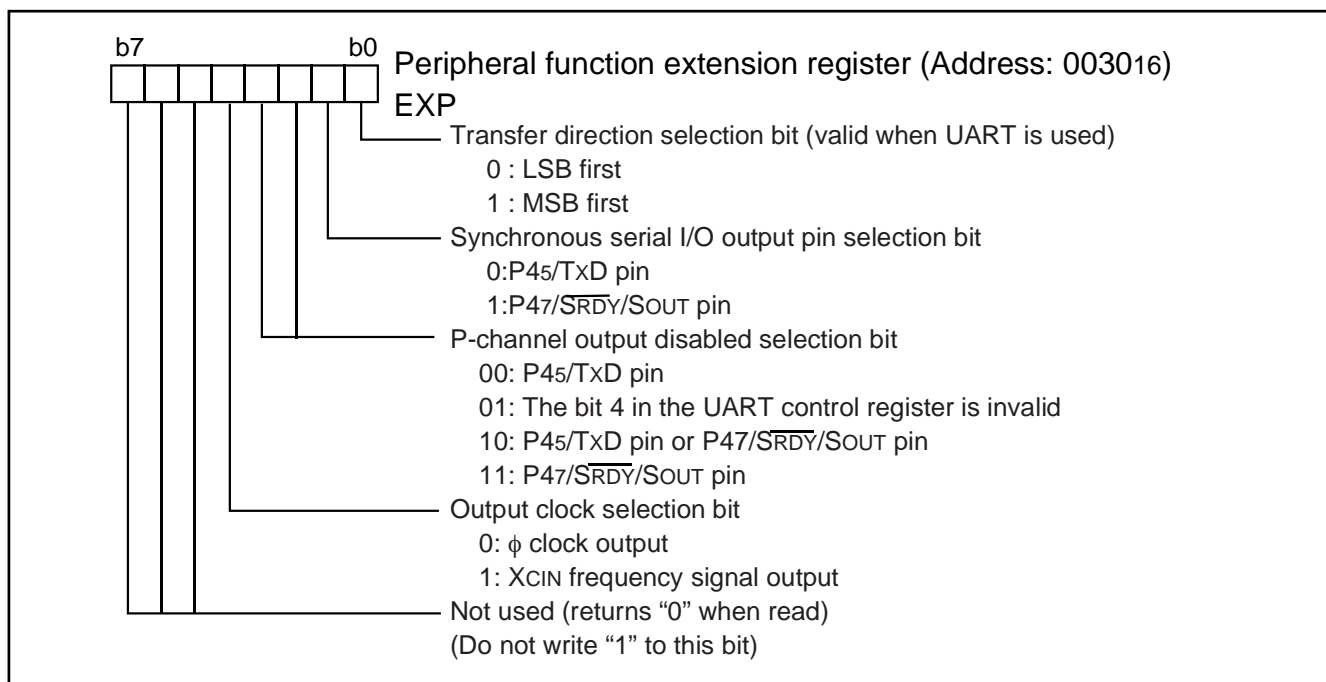

Fig. 50 Structure of peripheral function extension register

RESET CIRCUIT

To reset the microcomputer, $\overline{\text{RESET}}$ pin should be held at an “L” level for 2 μs or more. Then the $\overline{\text{RESET}}$ pin is returned to an “H” level (the power source voltage should be between $V_{CC}(\text{min.})$ and 5.5 V, and the quartz-crystal oscillator should be stable), reset is released. After the reset is completed, the program starts from the address contained in address FFFD_{16} (high-order byte) and address FFFC_{16} (low-order byte). Make sure that the reset input voltage meets V_{IL} spec. when a power source voltage passes $V_{CC}(\text{min.})$.

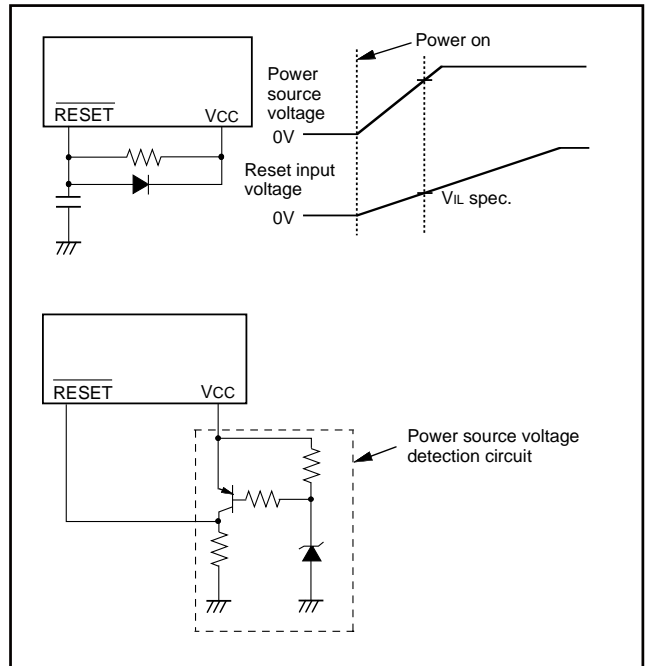

Fig. 51 Reset Circuit Example

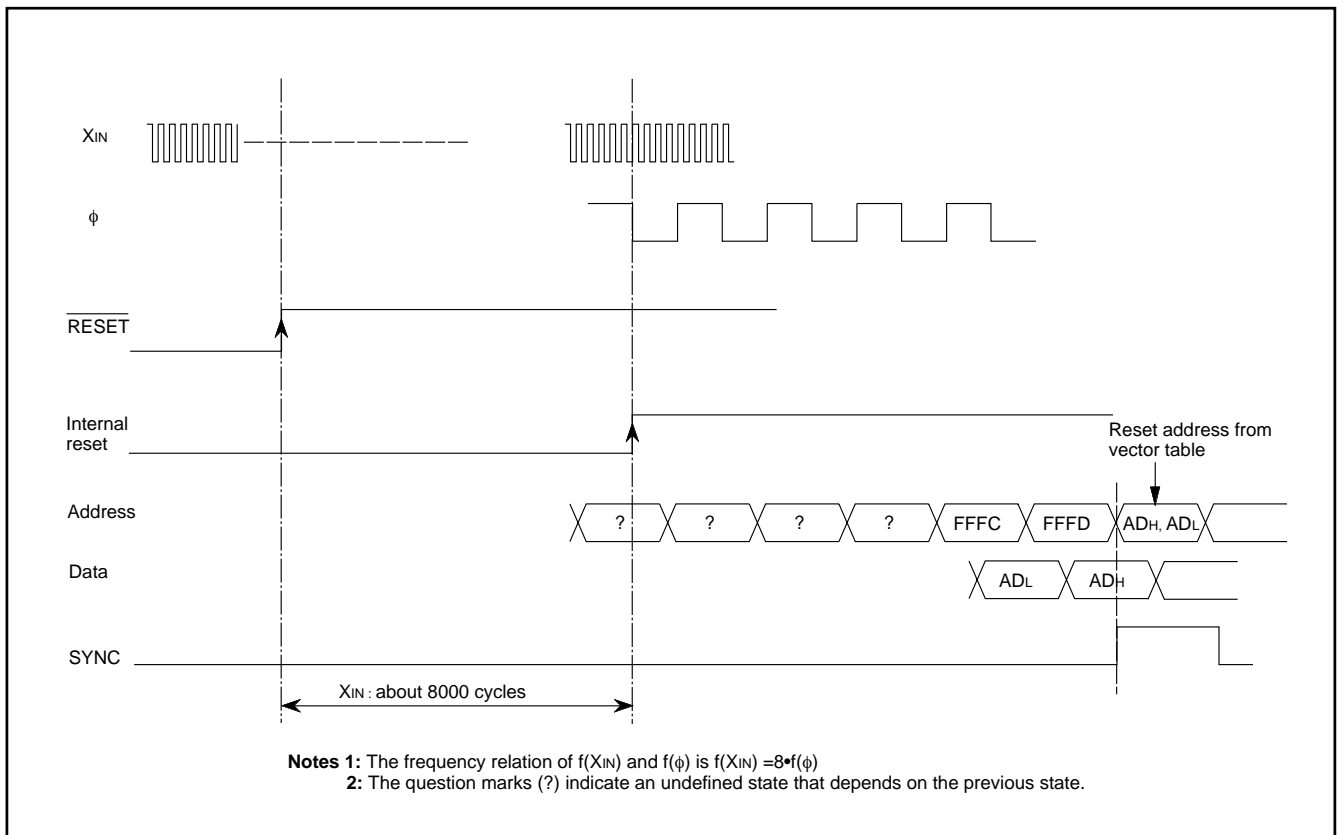

Fig. 52 Reset Sequence

	Address	Register Contents
(1) Port P0 direction register	000116	0016
(2) Port P1 direction register	000316	0016
(3) Port P2 direction register	000516	0016
(4) Port P4 direction register	000916	0016
(5) Port P5 direction register	000B16	0016
(6) Port P6 direction register	000D16	0016
(7) Port P7 direction register	000F16	0016
(8) ROM correctoin enable register (RCR)	001416	0016
(9) PULL register A	001616	0 0 0 0 1 0 1 1
(10) PULL register B	001716	0016
(11) Serial I/O status register	001916	1 0 0 0 0 0 0 0
(12) Serial I/O control register	001A16	0016
(13) UART control register	001B16	1 1 1 0 0 0 0 0
(14) Timer X high-order register	002016	FF16
(15) Timer X low-order register	002116	FF16
(16) Timer Y high-order register	002216	FF16
(17) Timer Y low-order register	002316	FF16
(18) Timer 1 register	002416	FF16
(19) Timer 2 register	002516	0116
(20) Timer 3 register	002616	FF16
(21) Timer X mode register	002716	0016
(22) Timer Y mode register	002816	0016
(23) Timer 123 mode register	002916	0016
(24) φ output control register	002A16	0016
(25) CPU mode extension register	002B16	0016
(26) Temporary data register 0	002C16	0016
(27) Temporary data register 1	002D16	0016
(28) Temporary data register 2	002E16	0016
(29) RRF register	002F16	0016
(30) Peripheral function extension register	003016	0016
(31) AD control register	003416	0 0 0 0 1 0 0 0
(32) AD conversion low-order register	003616	X X 0 0 0 0 0 0
(33) Watchdog timer control register	003716	0 0 1 1 1 1 1 1
(34) Segment output enable register	003816	0016
(35) LCD mode register	003916	0016
(36) Interrupt edge selection register	003A16	0016
(37) CPU mode register	003B16	0 1 0 0 1 0 0 0
(38) Interrupt request register 1	003C16	0016
(39) Interrupt request register 2	003D16	0016
(40) Interrupt control register 1	003E16	0016
(41) Interrupt control register 2	003F16	0016
(42) Processor status register	(PS)	X X X X X 1 X X
(43) Program counter	(PC+)	Contents of address FFFD16
	(PC-)	Contents of address FFFC16

Note: The contents of all other registers and RAM are undefined after reset, so they must be initialized by software.
X: undefined

Fig. 53 Initial status of microcomputer after reset

CLOCK GENERATING CIRCUIT

The 3823 group has two built-in oscillation circuits. An oscillation circuit can be formed by connecting a resonator between XIN and XOUT (XCIN and XCOUT). Use the circuit constants in accordance with the resonator manufacturer's recommended values. The oscillation start voltage and the oscillation start time differ in accordance with an oscillator, a circuit constant, or temperature, etc.

When power supply voltage is low and the high frequency oscillator is used, an oscillation start will require sufficient conditions. No external resistor is needed between XIN and XOUT since a feedback resistor exists on-chip. (an external feed-back resistor may be needed depending on conditions.) However, an external feedback resistor is needed between XCIN and XCOUT since a resistor does not exist between them.

To supply a clock signal externally, input it to the XIN pin and make the XOUT pin open. The sub-clock XCIN-XCOUT oscillation circuit cannot directly input clocks that are externally generated. Accordingly, be sure to cause an external resonator to oscillate. Immediately after poweron, only the XIN oscillation circuit starts oscillating, and XCIN and XCOUT pins function as I/O ports.

Frequency Control

(1) frequency/8 Mode

The internal clock ϕ is the frequency of XIN divided by 8. After reset, this mode is selected.

(2) frequency/4 Mode

The internal clock ϕ is the frequency of XIN divided by 4.

(3) frequency/2 Mode

The internal clock ϕ is half the frequency of XIN.

(4) Low-speed Mode

- The internal clock ϕ is the frequency of XIN or on-chip oscillation frequency divided by 2.

- A low-power consumption operation can be realized by stopping the main clock XIN in this mode. To stop the main clock, set bit 5 of the CPU mode register to "1".

When the main clock XIN is restarted, set enough time for oscillation to stabilize by programming.

In low speed mode, the system clock ϕ can be switched to the on-chip oscillator or XCIN. Use the on-chip oscillator control bit (bit 0 in the CPU mode expansion register) for settings. To set this bit to "0" from "1", wait until XCIN oscillation stabilizes.

Note 1: If you switch the mode between frequency/2/4/8 mode and low-speed, stabilize both XIN and XCIN oscillations.

The sufficient time is required for the sub-clock to stabilize, especially immediately after poweron and at returning from stop mode. When switching the mode between middle/high-speed and low-speed, set the frequency on condition that $f(XIN) > 3f(XCIN)$.

2: In frequency/2/4/8 mode, XIN-XOUT oscillation does not stop even if the main clock (XIN-XOUT) stop bit is set to "1".

3: In low speed mode, XCIN-XCOUT oscillation does not stop even if the port Xc switch bit is set to "0".

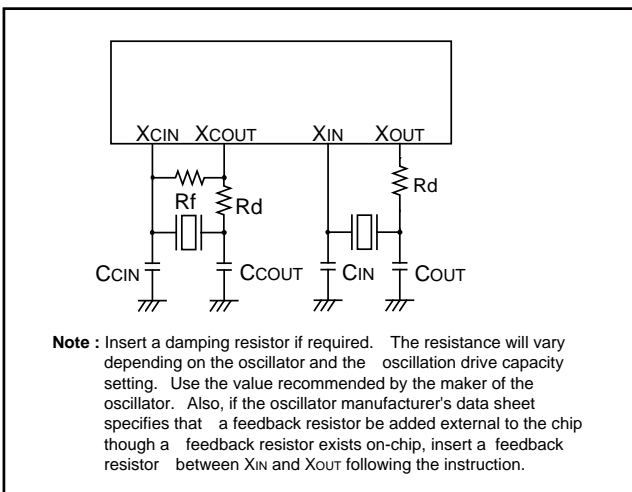

Fig. 54 Ceramic resonator circuit example

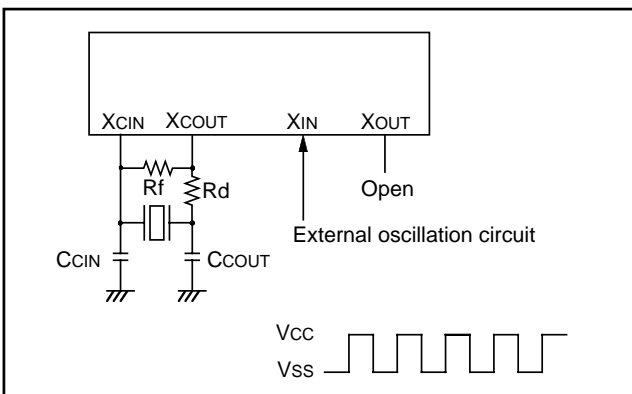

Fig. 55 External clock input circuit

Oscillation Control

(1) Stop Mode

If the STP instruction is executed, the internal clock ϕ stops at an "H" level, and XIN and XCIN oscillators stop. Timer 1 is set to "FF16" and timer 2 is set to "0116".

Either XIN or XCIN divided by 16 is input to timer 1 as count source, and the output of timer 1 is connected to timer 2. The bits of the timer 123 mode register except bit 4 are cleared to "0". Set the timer 1 and timer 2 interrupt enable bits to disabled ("0") before executing the STP instruction. Oscillator restarts at reset or when an external interrupt is received, but the internal clock ϕ is not supplied to the CPU until timer 2 underflows. This allows timer for the clock circuit oscillation to stabilize.

Execution of the STP instruction sets the LCD enable bit (bit 3 of the LCD mode register) to "0" and the LCD panel turns off. To make the LCD panel turn on after returning from the stop mode, set the LCD enable bit to "1".

(2) Wait Mode

If the WIT instruction is executed, only the system clock ϕ stops at an "H" state. The states of main clock, on-chip oscillator and sub clock are the same as the state before executing the WIT instruction, and oscillation does not stop. Since supply of system clock ϕ is started immediately after the interrupt is received, the instruction can be executed immediately.

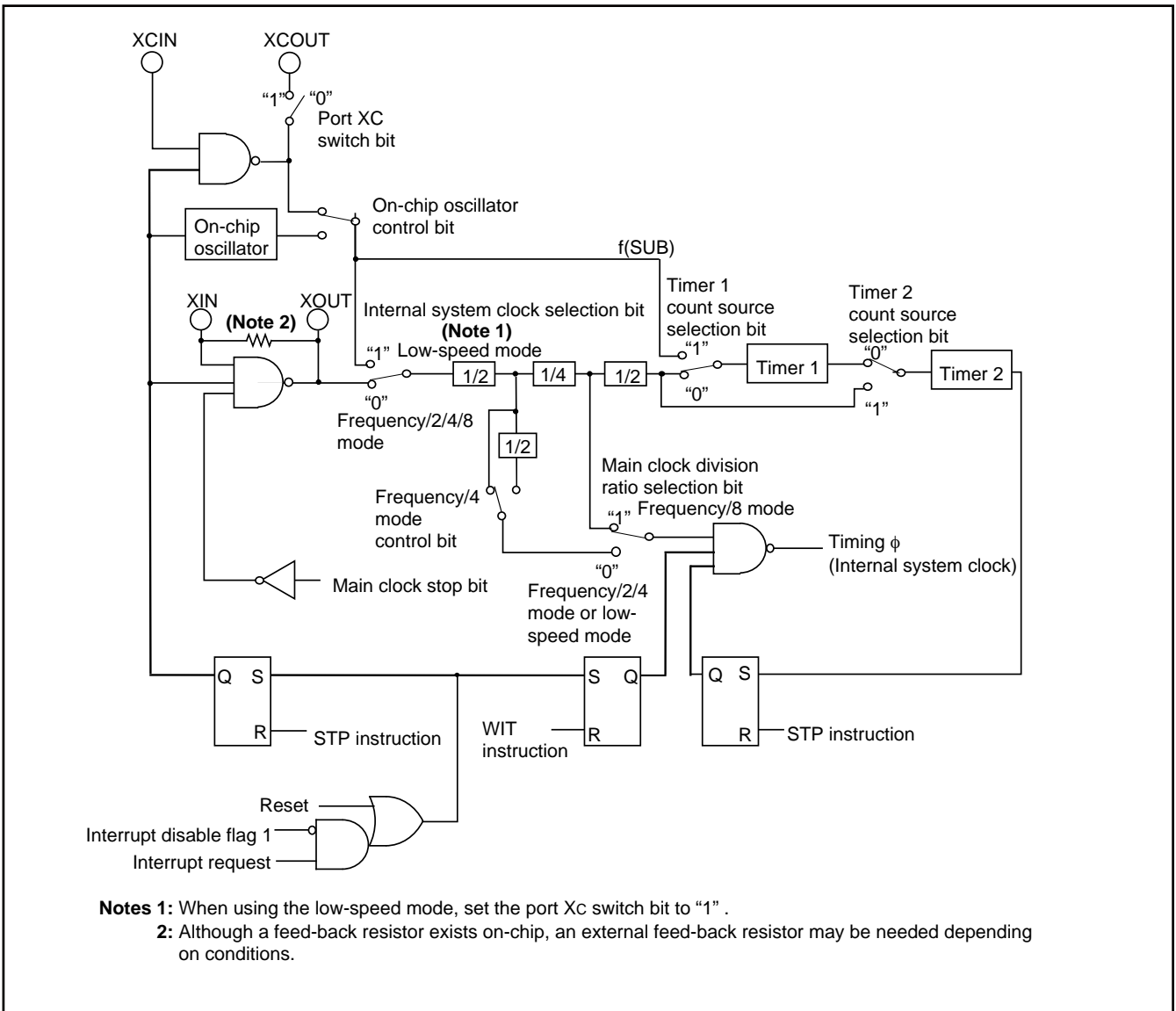

Fig. 56 Clock generating circuit block diagram

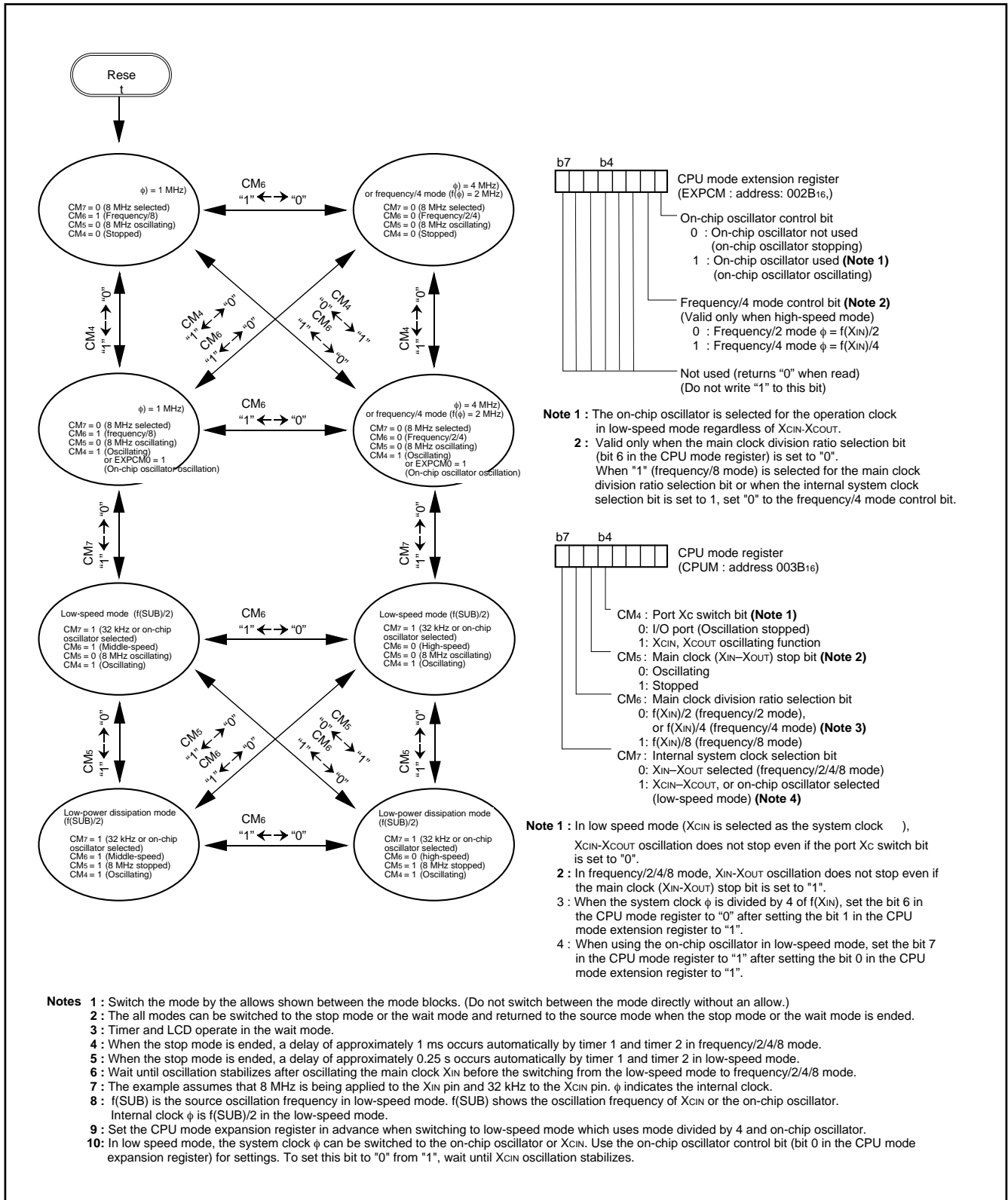

Fig. 57 State transitions of system clock

QzROM Writing Mode

In the QzROM writing mode, the user ROM area can be rewritten while the microcomputer is mounted on-board by using a serial programmer which is applicable for this microcomputer.

Table 13 lists the pin description (QzROM writing mode) and Figure 58 and Figure 59 show the pin connections.

Refer to Figure 60 and Figure 61 for examples of a connection with a serial programmer.

Contact the manufacturer of your serial programmer for serial programmer. Refer to the user's manual of your serial programmer for details on how to use it.

Table 13 Pin description (QzROM writing mode)

Pin	Name	I/O	Function
VCC, VSS	Power source	Input	• Apply 1.8 to 5.5 V to VCC, and 0 V to VSS.
RESET	Reset input	Input	• Reset input pin for active "L". Reset occurs when RESET pin is hold at an "L" level for 16 cycles or more of X _{IN} .
X _{IN}	Clock input	Input	• Set the same termination as the single-chip mode.
X _{OUT}	Clock output	Output	
VREF	Analog reference voltage	Input	• Input the reference voltage of A/D converter to VREF.
AVSS	Analog power source	Input	• Connect AVSS to VSS.
P00 –P07 P10 –P17 P20 –P27 P34 –P37 P41–P44 P50 –P57 P60 –P67	I/O port	I/O	• Input "H" or "L" level signal or leave the pin open.
P40	VPP input	Input	• QzROM programmable power source pin.
P44	ESDA input/output	I/O	• Serial data I/O pin.
P42	ESCLK input	Input	• Serial clock input pin.
P43	ESPGMB input	Input	• Read/program pulse input pin.

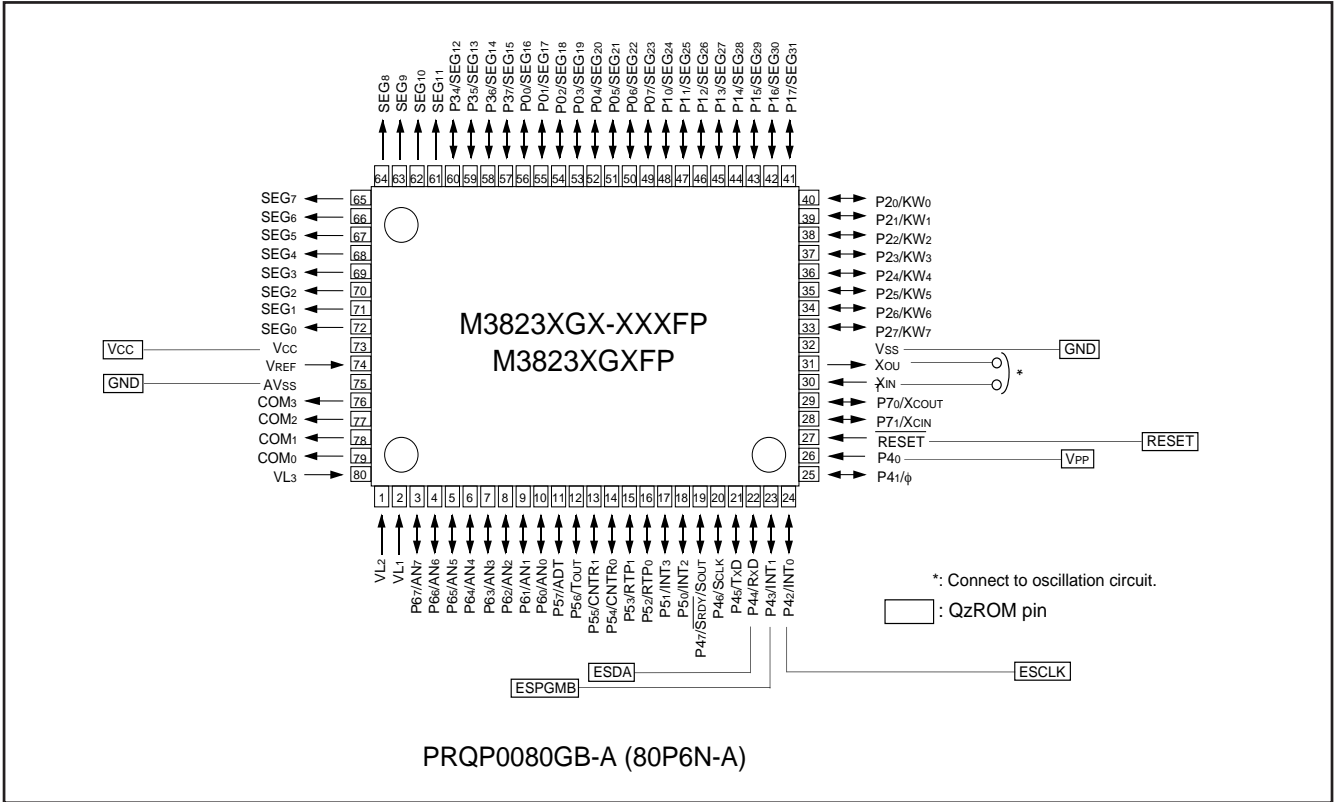

Fig. 58 Pin connection diagram (M3823XGX-XXXFP)

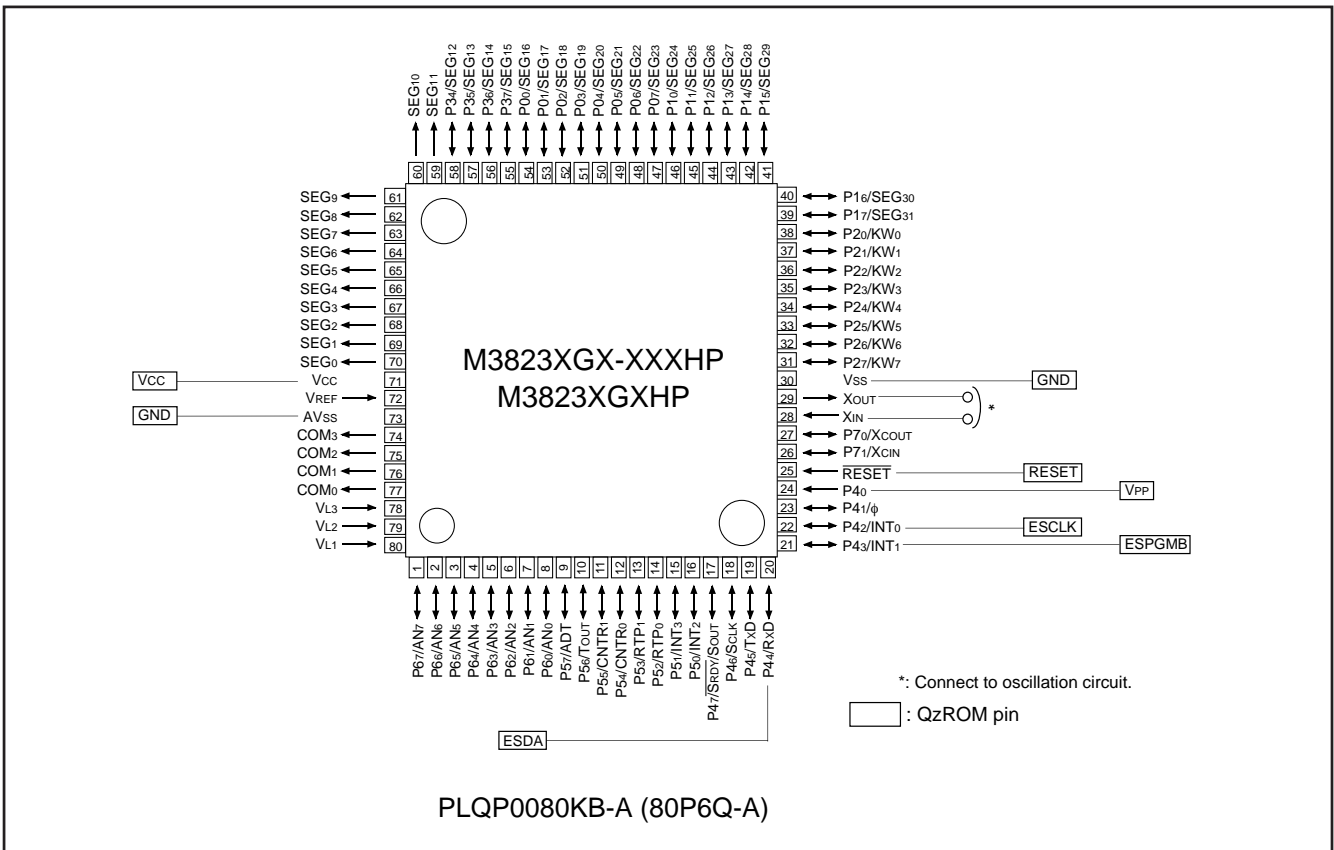

Fig. 59 Pin connection diagram (M3823XGX-XXXHP)

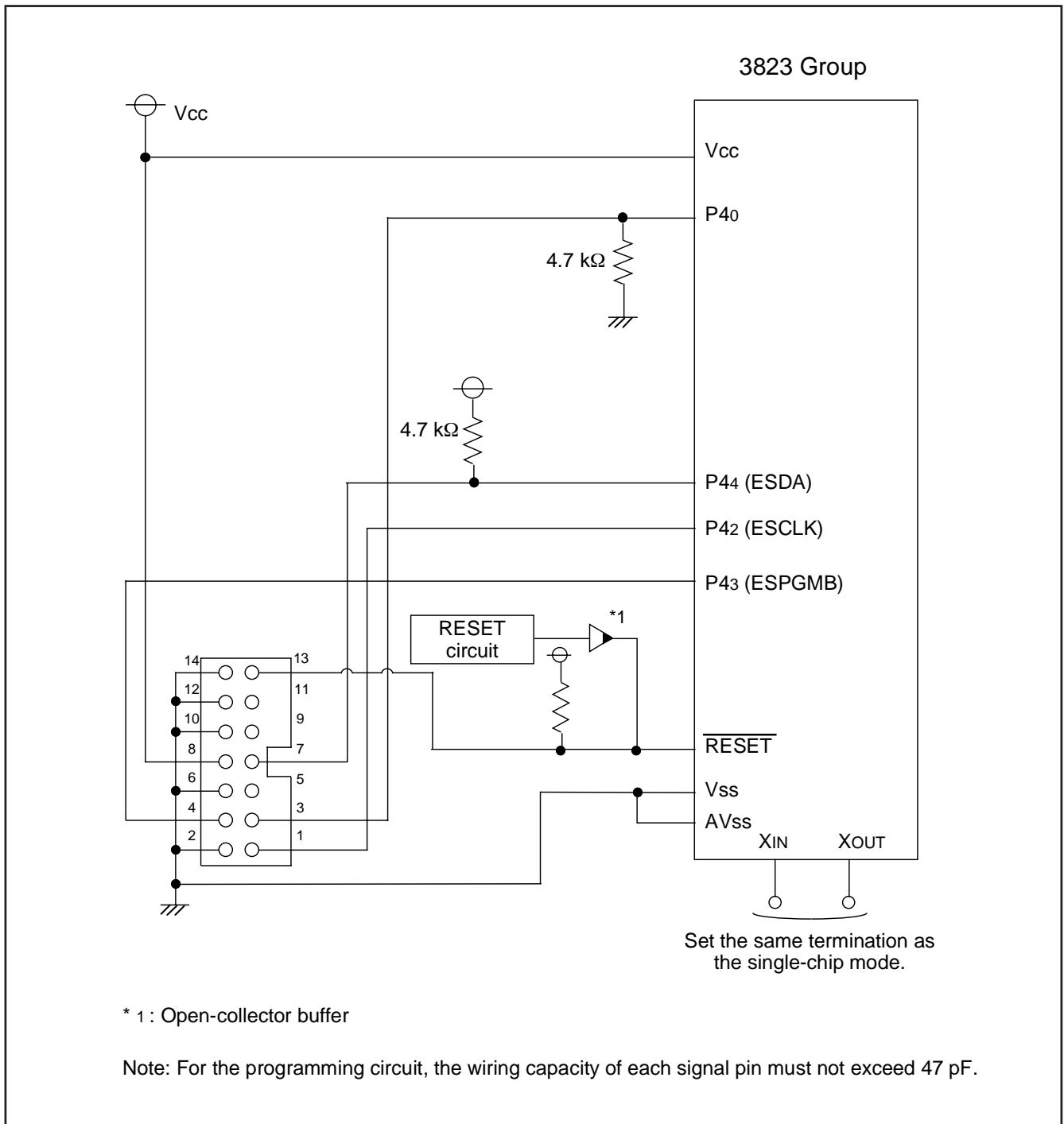

Fig. 60 When using E8 programmer, connection example

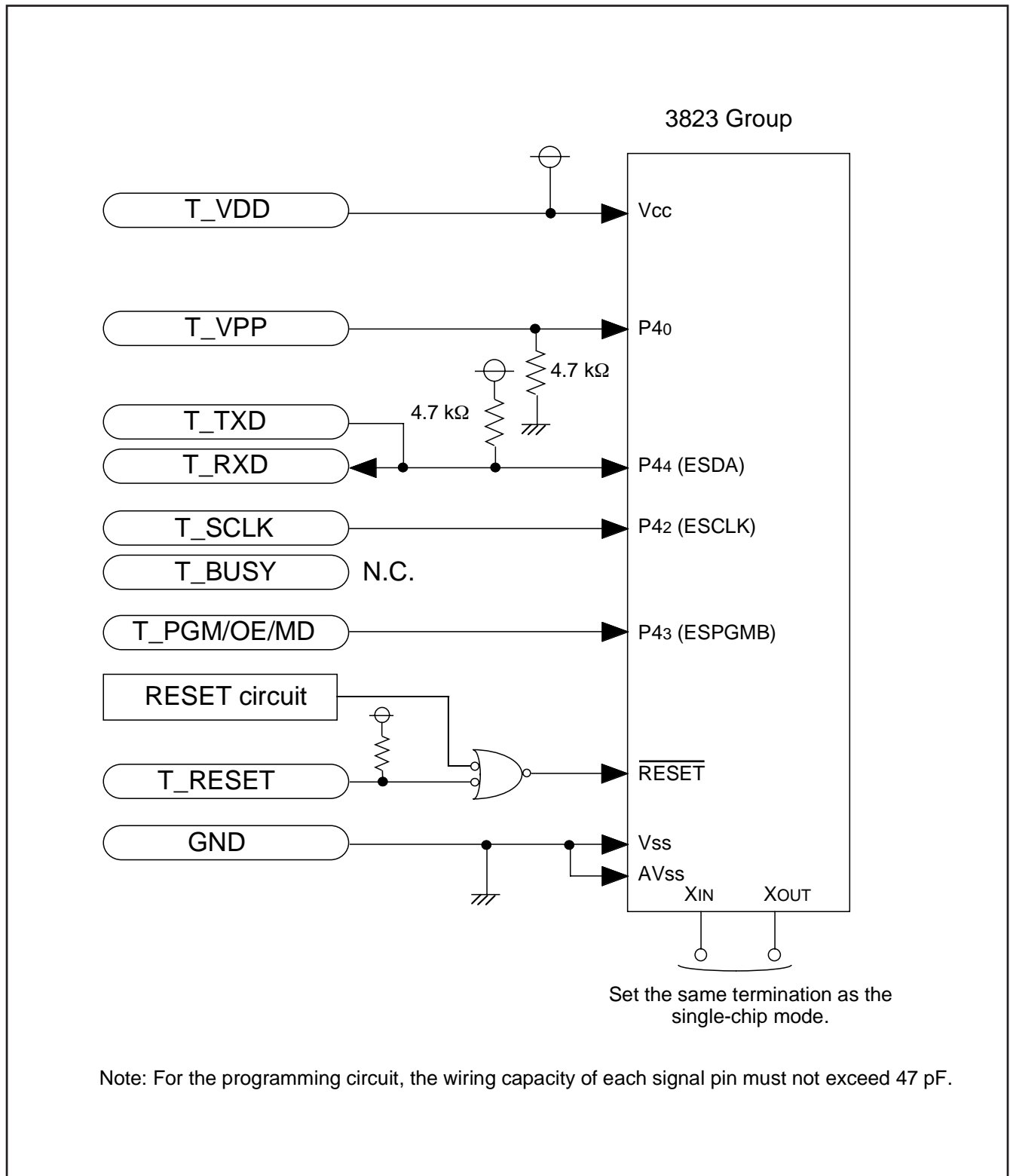

Fig. 61 When using programmer of Sisei Electronics System Co., LTD, connection example

NOTES ON PROGRAMMING

Processor Status Register

The contents of the processor status register (PS) after a reset are undefined, except for the interrupt disable flag (I) which is "1". After a reset, initialize flags which affect program execution.

In particular, it is essential to initialize the index X mode (T) and the decimal mode (D) flags because of their effect on calculations. Initialize these flags at the beginning of the program.

Interrupt

The contents of the interrupt request bits do not change immediately after they have been written. After writing to an interrupt request register, execute at least one instruction before performing a BBC or BBS instruction.

Decimal Calculations

- To calculate in decimal notation, set the decimal mode flag (D) to "1", then execute an ADC or SBC instruction. After executing an ADC or SBC instruction, execute at least one instruction before executing a SEC, CLC, or CLD instruction.
- In decimal mode, the values of the negative (N), overflow (V), and zero (Z) flags are invalid.

Timers

If a value n (between 0 and 255) is written to a timer latch, the frequency division ratio is $1/(n + 1)$.

Multiplication and Division Instructions

The index mode (T) and the decimal mode (D) flags do not affect the MUL and DIV instruction.

The execution of these instructions does not change the contents of the processor status register.

Ports

The contents of the port direction registers cannot be read.

The following cannot be used:

- The data transfer instruction (LDA, etc.)
- The operation instruction when the index X mode flag (T) is "1"
- The addressing mode which uses the value of a direction register as an index
- The bit-test instruction (BBC or BBS, etc.) to a direction register
- The read-modify-write instruction (ROR, CLB, or SEB, etc.) to a direction register

Use instructions such as LDM and STA, etc., to set the port direction registers.

Serial Interface

In clock synchronous serial I/O, if the receive side is using an external clock and it is to output the SRDY signal, set the transmit enable bit, the receive enable bit, and the SRDY output enable bit to "1".

Serial I/O continues to output the final bit from the TXD pin after transmission is completed.

A/D Converter

The comparator is constructed linked to a capacitor. The conversion accuracy may be low because the charge is lost if the conversion speed is not enough. Accordingly, set $f(XIN)$ to at least 500kHz during A/D conversion in the middle-or high-speed mode. Also, do not execute the STP or WIT instruction during an A/D conversion.

In the low-speed mode, since the A/D conversion is executed by the on-chip oscillator, the minimum value of $f(XIN)$ frequency is not limited.

LCD Drive Control Circuit

Execution of the STP instruction sets the LCD enable bit (bit 3 of the LCD mode register) to "0" and the LCD panel turns off. To make the LCD panel turn on after returning from the stop mode, set the LCD enable bit to "1".

Instruction Execution Time

The instruction execution time is obtained by multiplying the frequency of the internal clock ϕ by the number of cycles needed to execute an instruction.

The number of cycles required to execute an instruction is shown in the list of machine instructions.

The frequency of the internal clock ϕ is half of the XIN frequency.

Countermeasures against noise

(1) Shortest wiring length

① Wiring for RESET pin

Make the length of wiring which is connected to the RESET pin as short as possible. Especially, connect a capacitor across the RESET pin and the Vss pin with the shortest possible wiring (within 20mm).

● Reason

The width of a pulse input into the RESET pin is determined by the timing necessary conditions. If noise having a shorter pulse width than the standard is input to the RESET pin, the reset is released before the internal state of the microcomputer is completely initialized. This may cause a program runaway.

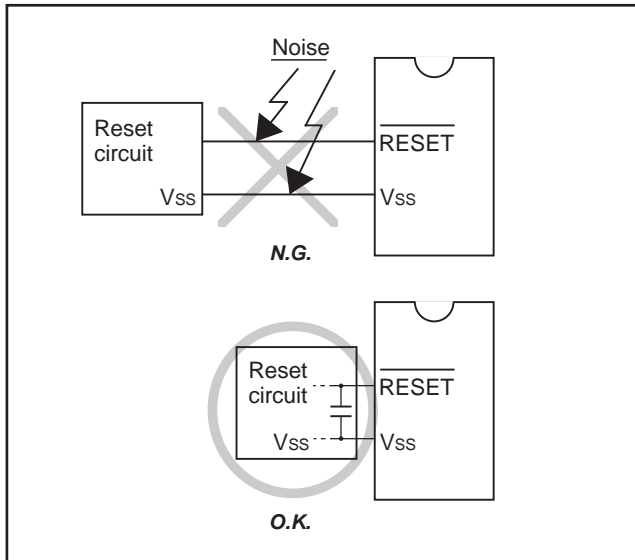

Fig. 62 Wiring for the RESET pin

② Wiring for clock input/output pins

- Make the length of wiring which is connected to clock I/O pins as short as possible.
- Make the length of wiring (within 20 mm) across the grounding lead of a capacitor which is connected to an oscillator and the Vss pin of a microcomputer as short as possible.
- Separate the Vss pattern only for oscillation from other Vss patterns.

● Reason

If noise enters clock I/O pins, clock waveforms may be deformed. This may cause a program failure or program runaway. Also, if a potential difference is caused by the noise between the Vss level of a microcomputer and the Vss level of an oscillator, the correct clock will not be input in the microcomputer.

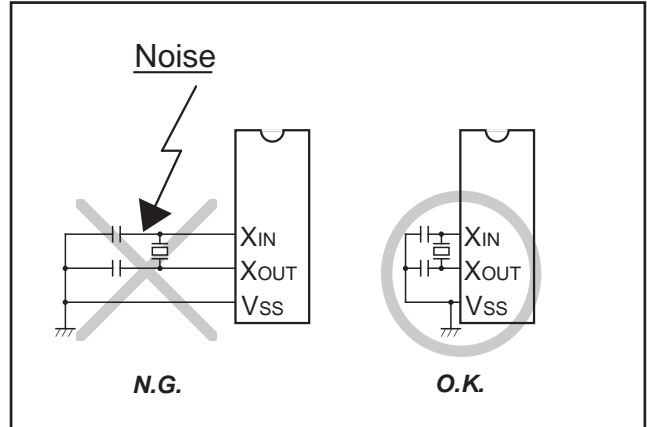

Fig. 63 Wiring for clock I/O pins

(2) Connection of bypass capacitor across Vss line and Vcc line
In order to stabilize the system operation and avoid the latch-up, connect an approximately 0.1 μF bypass capacitor across the Vss line and the Vcc line as follows:

- Connect a bypass capacitor across the Vss pin and the Vcc pin at equal length.
- Connect a bypass capacitor across the Vss pin and the Vcc pin with the shortest possible wiring.
- Use lines with a larger diameter than other signal lines for Vss line and Vcc line.
- Connect the power source wiring via a bypass capacitor to the Vss pin and the Vcc pin.

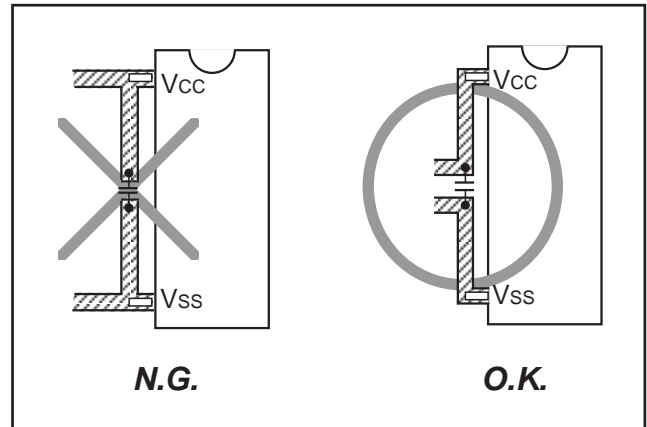

Fig. 64 Bypass capacitor across the Vss line and the Vcc line

(3) Oscillator concerns

In order to obtain the stabilized operation clock on the user system and its condition, contact the oscillator manufacturer and select the oscillator and oscillation circuit constants. Be careful especially when range of voltage and temperature is wide.

Also, take care to prevent an oscillator that generates clocks for a microcomputer operation from being affected by other signals.

① Keeping oscillator away from large current signal lines

Install a microcomputer (and especially an oscillator) as far as possible from signal lines where a current larger than the tolerance of current value flows.

● Reason

In the system using a microcomputer, there are signal lines for controlling motors, LEDs, and thermal heads or others. When a large current flows through those signal lines, strong noise occurs because of mutual inductance.

② Installing oscillator away from signal lines where potential levels change frequently

Install an oscillator and a connecting pattern of an oscillator away from signal lines where potential levels change frequently. Also, do not cross such signal lines over the clock lines or the signal lines which are sensitive to noise.

● Reason

Signal lines where potential levels change frequently (such as the CNTR pin signal line) may affect other lines at signal rising edge or falling edge. If such lines cross over a clock line, clock waveforms may be deformed, which causes a microcomputer failure or a program runaway.

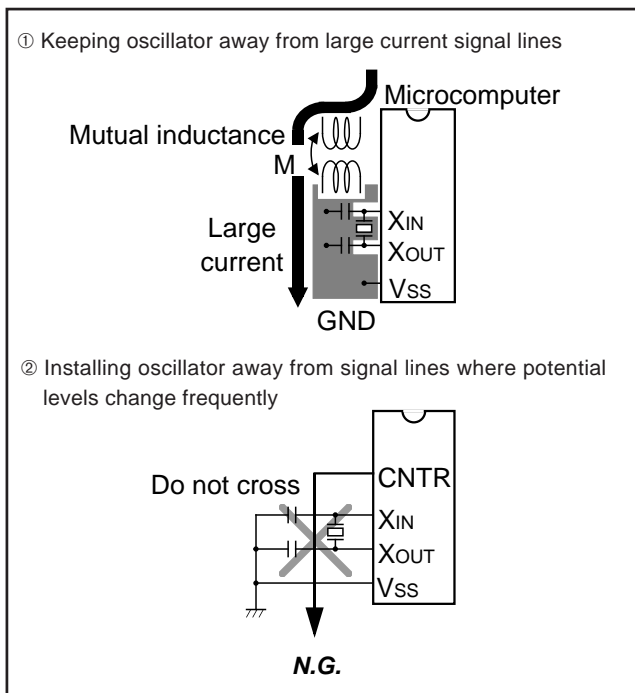

Fig. 65 Wiring for a large current signal line/Wiring of signal lines where potential levels change frequently

(4) Analog input

The analog input pin is connected to the capacitor of a voltage comparator. Accordingly, sufficient accuracy may not be obtained by the charge/discharge current at the time of A/D conversion when the analog signal source of high-impedance is connected to an analog input pin. In order to obtain the A/D conversion result stabilized more, please lower the impedance of an analog signal source, or add the smoothing capacitor to an analog input pin.

(5) Difference of memory size

When memory size differ in one group, actual values such as an electrical characteristics, A/D conversion accuracy, and the amount of -proof of noise incorrect operation may differ from the ideal values. When these products are used switching, perform system evaluation for each product of every after confirming product specification.

(6) Wiring to P40/(VPP) pin

When using P40/(VPP) pin as an input port, connect an approximately 5 kΩ resistor to the P40/(VPP) pin the shortest possible in series.

When not using P40/(VPP) pin, connect the pin the shortest possible to the GND pattern which is supplied to the Vss pin of the microcomputer. In addition connecting an approximately 5 kΩ resistor in series to the GND could improve noise immunity. In this case as well as the above mention, connect the pin the shortest possible to the GND pattern which is supplied to the Vss pin of the microcomputer.

● Reason

The P40/(VPP) pin of the QzROM version is the power source input pin for the built-in QzROM. When programming in the QzROM, the impedance of the VPP pin is low to allow the electric current for writing to flow into the built-in QzROM. Because of this, noise can enter easily. If noise enters the P40/(VPP) pin, abnormal instruction codes or data are read from the QzROM, which may cause a program runaway.

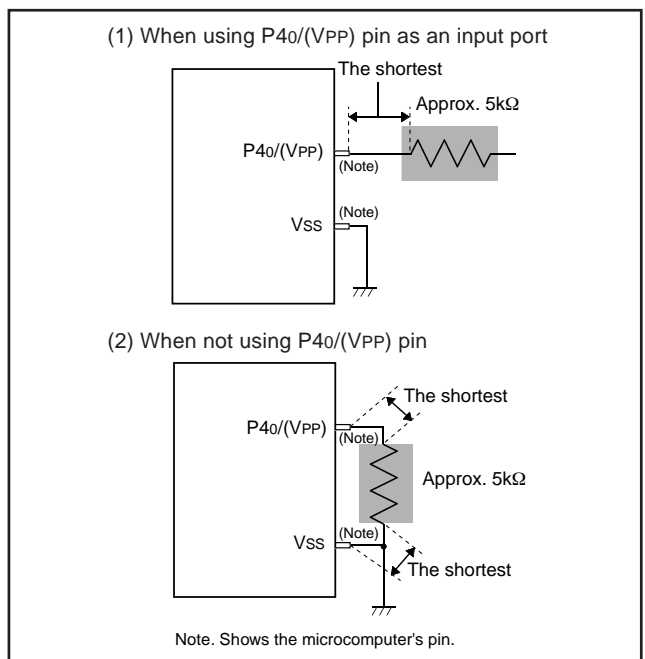

Fig. 66 Wiring for the P40/(VPP) pin

NOTES ON USE
Power Source Voltage

When the power source voltage value of a microcomputer is less than the value which is indicated as the recommended operating conditions, the microcomputer does not operate normally and may perform unstable operation.

In a system where the power source voltage drops slowly when the power source voltage drops or the power supply is turned off, reset a microcomputer when the power source voltage is less than the recommended operating conditions and design a system not to cause errors to the system by this unstable operation.

LCD drive power supply

Power supply capacitor may be insufficient with the division resistance for LCD power supply, and the characteristic of the LCD panel. In this case, there is the method of connecting the bypass capacitor about 0.1 – 0.33µF to VL1 – VL3 pins. The example of a strengthening measure of the LCD drive power supply is shown in Figure 67.

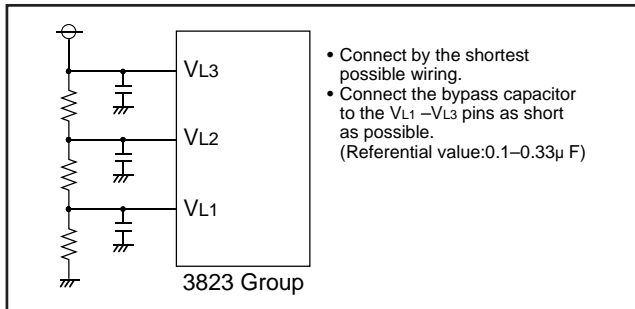

Fig. 67 Strengthening measure example of LCD drive power supply

Product shipped in blank

As for the product shipped in blank, Renesas does not perform the writing test to user ROM area after the assembly process though the QzROM writing test is performed enough before the assembly process. Therefore, a writing error of approx. 0.1 % may occur. Moreover, please note the contact of cables and foreign bodies on a socket, etc. because a writing environment may cause some writing errors.

Overvoltage

Make sure that voltage exceeding the Vcc pin voltage is not applied to other pins. In particular, ensure that the state indicated by bold lines in figure below does not occur for pin P40 (VPP power source pin for QzROM) during power-on or power-off. Otherwise the contents of QzROM could be rewritten.

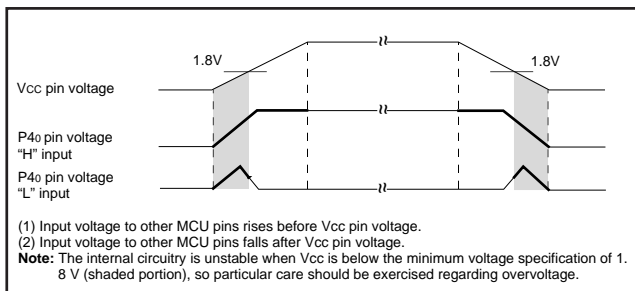

Fig. 68 Timing Diagram (Applies to section indicated by bold line.)

NOTES ON QzROM
Notes On QzROM Writing Orders

When ordering the QzROM product shipped after writing, submit the mask file (extension: .msk) which is made by the mask file converter MM.

Be sure to set the ROM option ("MASK option" written in the mask file converter) setup when making the mask file by using the mask file converter MM.

Notes On ROM Code Protect
(QzROM product shipped after writing)

As for the QzROM product shipped after writing, the ROM code protect is specified according to the ROM option setup data in the mask file which is submitted at ordering.

The ROM option setup data in the mask file is "0016" for protect enabled or "FF16" for protect disabled. Therefore, the contents of the ROM code protect address (other than the user ROM area) of the QzROM product shipped after writing is "0016" or "FF16".

Note that the mask file which has nothing at the ROM option data or has the data other than "0016" and "FF16" can not be accepted.

DATA REQUIRED FOR QzROM WRITING ORDERS

The following are necessary when ordering a QzROM product shipped after writing:

1. QzROM Writing Confirmation Form*
2. Mark Specification Form*
3. ROM data.....Mask file

* For the QzROM writing confirmation form and the mark specification form, refer to the "Renesas Technology Corp." Homepage (<http://www.renesas.com>).

Note that we cannot deal with special font marking (customer's trademark etc.) in QzROM microcomputer.

ELECTRICAL CHARACTERISTICS

Table 14 Absolute maximum ratings

Symbol	Parameter	Conditions	Ratings	Unit
VCC	Power source voltage	All voltages are based on VSS. When an input voltage is measured, output transistors are cut off.	-0.3 to 6.5	V
Vi	Input voltage P00–P07, P10–P17, P20–P27, P34–P37, P40–P47, P50–P57, P60–P67, P70, P71		-0.3 to VCC +0.3	V
Vi	Input voltage VL1		-0.3 to VL2	V
Vi	Input voltage VL2		VL1 to VL3	V
Vi	Input voltage VL3		VL2 to 6.5	V
Vi	Input voltage RESET, XIN		-0.3 to VCC +0.3	V
Vo	Output voltage P00–P07, P10–P17	At output port	-0.3 to VCC +0.3	V
		At segment output	-0.3 to VL3	V
Vo	Output voltage P34–P37	At segment output	-0.3 to VL3	V
Vo	Output voltage P20–P27, P41–P47, P50–P57, P60–P67, P70, P71		-0.3 to VCC +0.3	V
Vo	Output voltage SEG0–SEG11		-0.3 to VL3	V
Vo	Output voltage XOUT		-0.3 to VCC +0.3	V
Pd	Power dissipation	Ta = 25°C	300	mW
Topr	Operating temperature		-20 to 85	°C
Tstg	Storage temperature		-40 to 150	°C

Table 15 Recommended operating conditions (1)

(VCC = 1.8 to 5.5 V, Ta = -20 to 85 °C, unless otherwise noted)

Symbol	Parameter		Limits			Unit	
			Min.	Typ.	Max.		
VCC	Power source voltage (Note 1)	Frequency/2 mode	f(XIN) = 10 MHz	4.5	5.0	5.5	V
			f(XIN) = 8 MHz	4.0	5.0	5.5	V
			f(XIN) = 5 MHz	2.0	5.0	5.5	V
			f(XIN) = 2.5 MHz	1.8	5.0	5.5	V
		Frequency/4 mode	f(XIN) = 10 MHz	2.5	5.0	5.5	V
			f(XIN) = 8 MHz	2.0	5.0	5.5	V
			f(XIN) = 5 MHz	1.8	5.0	5.5	V
		Frequency/8 mode	f(XIN) = 10 MHz	2.5	5.0	5.5	V
			f(XIN) = 8 MHz	2.0	5.0	5.5	V
			f(XIN) = 5 MHz	1.8	5.0	5.5	V
	Low-speed mode (OCO included)		1.8	5.0	5.5	V	
VSS	Power source voltage			0		V	
VL3	LCD power voltage		2.5		5.5	V	
VREF	A/D conversion reference voltage		1.8		VCC	V	
AVSS	Analog power source voltage			0		V	
VIA	Analog input voltage AN0–AN7		AVSS		VREF	V	

Note : When the A/D converter is used, refer to the recommended operating condition for A/D converter.

Table 16 Recommended operating conditions (2)(V_{CC} = 1.8 to 5.5 V, T_a = -20 to 85 °C, unless otherwise noted)

Symbol	Parameter		Limits			Unit
			Min.	Typ.	Max.	
V _{IH}	"H" input voltage	P00–P07, P10–P17, P34–P37, P40, P41, P45, P47, P52, P53, P56, P60–P67, P70, P71 (CM4= 0)	0.7V _{CC}		V _{CC}	V
V _{IH}	"H" input voltage	P20–P27, P42–P44, P46, P50, P51, P54, P55, P57	0.8V _{CC}		V _{CC}	V
V _{IH}	"H" input voltage	$\overline{\text{RESET}}$	0.8V _{CC}		V _{CC}	V
V _{IH}	"H" input voltage	X _{IN}	0.8V _{CC}		V _{CC}	V
V _{IL}	"L" input voltage	P00–P07, P10–P17, P34–P37, P40, P41, P45, P47, P52, P53, P56, P60–P67, P70, P71 (CM4= 0)	0		0.3 V _{CC}	V
V _{IL}	"L" input voltage	P20–P27, P42–P44, P46, P50, P51, P54, P55, P57	0		0.2 V _{CC}	V
V _{IL}	"L" input voltage	$\overline{\text{RESET}}$	0		0.2 V _{CC}	V
V _{IL}	"L" input voltage	X _{IN}	0		0.2 V _{CC}	V

Table 17 Recommended operating conditions (3)

(VCC = 1.8 to 5.5 V, Ta = -20 to 85 °C, unless otherwise noted)

Symbol	Parameter	Limits			Unit
		Min.	Typ.	Max.	
$\Sigma I_{OH(peak)}$	"H" total peak output current P00–P07, P10–P17, P20–P27 (Note 1)			–40	mA
$\Sigma I_{OH(peak)}$	"H" total peak output current P41–P47, P50–P57, P60–P67, P70, P71 (Note 1)			–40	mA
$\Sigma I_{OL(peak)}$	"L" total peak output current P00–P07, P10–P17, P20–P27 (Note 1)			40	mA
$\Sigma I_{OL(peak)}$	"L" total peak output current P41–P47, P50–P57, P60–P67, P70, P71 (Note 1)			40	mA
$\Sigma I_{OH(avg)}$	"H" total average output current P00–P07, P10–P17, P20–P27 (Note 1)			–20	mA
$\Sigma I_{OH(avg)}$	"H" total average output current P41–P47, P50–P57, P60–P67, P70, P71 (Note 1)			–20	mA
$\Sigma I_{OL(avg)}$	"L" total average output current P00–P07, P10–P17, P20–P27 (Note 1)			20	mA
$\Sigma I_{OL(avg)}$	"L" total average output current P41–P47, P50–P57, P60–P67, P70, P71 (Note 1)			20	mA
$I_{OH(peak)}$	"H" peak output current P00–P07, P10–P17 (Note 2)			–2	mA
$I_{OH(peak)}$	"H" peak output current P20–P27, P41–P47, P50–P57, P60–P67, P70, P71 (Note 2)			–5	mA
$I_{OL(peak)}$	"L" peak output current P00–P07, P10–P17 (Note 2)			5	mA
$I_{OL(peak)}$	"L" peak output current P20–P27, P41–P47, P50–P57, P60–P67, P70, P71 (Note 2)			10	mA
$I_{OH(avg)}$	"H" average output current P00–P07, P10–P17 (Note 3)			–1.0	mA
$I_{OH(avg)}$	"H" average output current P20–P27, P41–P47, P50–P57, P60–P67, P70, P71 (Note 3)			–2.5	mA
$I_{OL(avg)}$	"L" average output current P00–P07, P10–P17 (Note 3)			2.5	mA
$I_{OL(avg)}$	"L" average output current P20–P27, P41–P47, P50–P57, P60–P67, P70, P71 (Note 3)			5.0	mA
$f(CNTR0)$ $f(CNTR1)$	Input frequency for timers X and Y (duty cycle 50%)	(4.5 V ≤ VCC ≤ 5.5 V)		5.0	MHz
		(4.0 V ≤ VCC ≤ 4.5 V)		2 X VCC – 4	MHz
		(2.0 V ≤ VCC ≤ 4.0 V)		0.75 X VCC + 1	MHz
		(VCC ≤ 2.0 V)		6.25 X VCC - 10	MHz
$f(XIN)$	Main clock input oscillation frequency (duty cycle 50%) (Note 4)	Frequency/2 mode (4.5 V ≤ VCC ≤ 5.5 V)		10.0	MHz
		Frequency/2 mode (4.0 V ≤ VCC ≤ 4.5 V)		4 X VCC – 8	MHz
		Frequency/2 mode (2.0 V ≤ VCC ≤ 4.0 V)		1.5 X VCC + 2	MHz
		Frequency/2 mode (1.8 V ≤ VCC ≤ 2.0 V)		12.5 X VCC - 20	MHz
		Frequency/4 mode (2.5 V ≤ VCC ≤ 5.5 V)		10.0	MHz
		Frequency/4 mode (2.0 V ≤ VCC ≤ 2.5 V)		4 X VCC	MHz
		Frequency/4 mode (1.8 V ≤ VCC ≤ 2.0 V)		15 X VCC – 22	MHz
		Frequency/8 mode (2.5 V ≤ VCC ≤ 5.5 V)		10.0	MHz
		Frequency/8 mode (2.0 V ≤ VCC ≤ 2.5 V)		4 X VCC	MHz
		Frequency/8 mode (1.8 V ≤ VCC ≤ 2.0 V)		15 X VCC – 22	MHz
$f(XCIN)$	Sub-clock input oscillation frequency (duty cycle 50%) (Note 5)		32.768	80	kHz

Notes 1: The total output current is the sum of all the currents flowing through all the applicable ports. The total average current is an average value measured over 100 ms. The total peak current is the peak value of all the currents.

2: The peak output current is the peak current flowing in each port.

3: The average output current is an average value measured over 100 ms.

4: When the A/D converter is used, refer to the recommended operating condition for A/D converter.

5: When using the microcomputer in low-speed mode, make sure that the sub-clock input oscillation frequency on condition that $f(XCIN) < f(XIN)/3$.

Table 18 Electrical characteristics (1)(V_{CC} = 4.0 to 5.5 V, T_a = -20 to 85 °C, unless otherwise noted)

Symbol	Parameter	Test conditions	Limits			Unit
			Min.	Typ.	Max.	
V _{OH}	"H" output voltage P00–P07, P10–P17	I _{OH} = -2.5 mA	V _{CC} -2.0			V
		I _{OH} = -0.6 mA V _{CC} = 2.5 V	V _{CC} -1.0			V
V _{OH}	"H" output voltage P20–P27, P41–P47, P50–P57, P60–P67, P70, P71 (Note)	I _{OH} = -5 mA	V _{CC} -2.0			V
		I _{OH} = -1.25 mA	V _{CC} -0.5			V
		I _{OH} = -1.25 mA V _{CC} = 2.5 V	V _{CC} -1.0			V
V _{OL}	"L" output voltage P00–P07, P10–P17	I _{OL} = 5 mA			2.0	V
		I _{OL} = 1.25 mA			0.5	V
		I _{OL} = 1.25 mA V _{CC} = 2.5 V			1.0	V
V _{OL}	"L" output voltage P20–P27, P41–P47, P50–P57, P60–P67, P70, P71 (Note)	I _{OL} = 10 mA			2.0	V
		I _{OL} = 2.5 mA			0.5	V
		I _{OL} = 2.5 mA V _{CC} = 2.5 V			1.0	V
V _{T+} – V _{T-}	Hysteresis INT0–INT3, ADT, CNTR0, CNTR1, P20–P27			0.5		V
V _{T+} – V _{T-}	Hysteresis SCLK, RxD			0.5		V
V _{T+} – V _{T-}	Hysteresis RESET	RESET : V _{CC} = 2.0 V to 5.5 V		0.5		V
I _{IH}	"H" input current P00–P07, P10–P17, P34–P37	V _I = V _{CC} Pull-downs "off"			5.0	μA
		V _{CC} = 5 V, V _I = V _{CC} Pull-downs "on"	30	70	140	μA
		V _{CC} = 3 V, V _I = V _{CC} Pull-downs "on"	6.0	25	45	μA
I _{IH}	"H" input current P20–P27, P40–P47, P50–P57, P60–P67, P70, P71 (Note)	V _I = V _{CC}			5.0	μA
I _{IH}	"H" input current RESET	V _I = V _{CC}			5.0	μA
I _{IH}	"H" input current X _{IN}	V _I = V _{CC}		4.0		μA
I _{IL}	"L" input current P00–P07, P10–P17, P34–P37, P40	V _I = V _{SS}			-5.0	μA
I _{IL}	"L" input current P20–P27, P41–P47, P50–P57, P60–P67, P70, P71 (Note)	V _I = V _{SS} Pull-ups "off"			-5.0	μA
		V _{CC} = 5 V, V _I = V _{SS} Pull-ups "on"	-30	-70	-140	μA
		V _{CC} = 3 V, V _I = V _{SS} Pull-ups "on"	-6.0	-25	-45	μA
I _{IL}	"L" input current RESET	V _I = V _{SS}			-5.0	μA
I _{IL}	"L" input current X _{IN}	V _I = V _{SS}		-4.0		μA
V _{RAM}	RAM hold voltage	When clock is stopped	1.8		5.5	V

Note: When "1" is set to the port X_C switch bit (bit 4 at address 003B16) of CPU mode register, the drive ability of port P70 is different from the value above mentioned.

Table 19 Electrical characteristics (2)

(VCC = 1.8 to 5.5 V, Ta = -20 to 85 °C, unless otherwise noted)

Symbol	Parameter	Test conditions			Limits			Unit
					Min.	Typ.	Max.	
Icc	Power source current	Frequency/2 mode	VCC = 5.0 V	f(XIN) = 10 MHz		4.3	8.6	mA
				f(XIN) = 8 MHz		3.7	7.4	mA
				f(XIN) = 4 MHz		2.5	5.0	mA
			VCC = 2.5 V	f(XIN) = 4 MHz		0.8	1.6	mA
				f(XIN) = 2 MHz		0.4	0.8	mA
		Frequency/4 mode	VCC = 5.0 V	f(XIN) = 10 MHz		2.9	5.8	mA
				f(XIN) = 8 MHz		2.5	5.0	mA
				f(XIN) = 4 MHz		1.7	3.4	mA
			VCC = 2.5 V	f(XIN) = 10 MHz		1.0	2.0	mA
				f(XIN) = 8 MHz		0.8	1.6	mA
				f(XIN) = 4 MHz		0.5	1.0	mA
		Frequency/8 mode	VCC = 5.0 V	f(XIN) = 10 MHz		2.2	4.4	mA
				f(XIN) = 8 MHz		1.9	3.8	mA
				f(XIN) = 4 MHz		1.4	2.8	mA
			VCC = 2.5 V	f(XIN) = 2 MHz		1.0	2.0	mA
				f(XIN) = 10 MHz		0.7	1.4	mA
				f(XIN) = 8 MHz		0.6	1.2	mA
		Frequency/2/4/8 mode In WIT state	VCC = 5.0 V	f(XIN) = 4 MHz		0.4	0.8	mA
				f(XIN) = 2 MHz		0.2	0.4	mA
			VCC = 2.5 V	f(XIN) = 10 MHz		1.35	2.7	mA
				f(XIN) = 8 MHz		1.2	2.4	mA
				f(XIN) = 4 MHz		0.9	1.8	mA
		Low-speed mode f(XIN) = stopped	VCC = 5.0 V	f(XIN) = 2 MHz		0.8	1.6	mA
			VCC = 2.5 V	f(XIN) = 10 MHz		0.35	0.7	mA
				On-chip oscillator		80	240	μA
			VCC = 5.0 V	f(XIN) = 8 MHz		0.3	0.6	mA
				On-chip oscillator		14	42	μA
		VCC = 2.5 V	f(XIN) = 4 MHz		0.2	0.4	mA	
			On-chip oscillator		3.5	10	μA	
Current increased at A/D converter operating	VCC = 5 V, all modes			500		μA		
	VCC = 2.5 V, all modes			50		μA		
All oscillation stopped Ta = 25 °C, Output transistors "off" (in STP state)				0.1	1.0	μA		
All oscillation stopped Ta = 85 °C, Output transistors "off" (in STP state)					10	μA		
Roco	On-chip oscillator oscillation	VCC = 2.5 V, Ta = 25 °C				80		kHz

Table 20 A/D converter characteristics (1) (in 8 bit A/D mode)

(VCC = 1.8 to 5.5 V, Ta = -20 to 85 °C, unless otherwise noted)

Symbol	Parameter	Test conditions	Limits			Unit
			Min.	Typ.	Max.	
–	Resolution				8	Bits
ABS	Absolute accuracy (excluding quantization error)	ADL2 = "0", ADL1 = "0", CPUM7 = "0" 2.2 V ≤ VCC = VREF ≤ 5.5 V f(XIN) = 2 × VCC MHz ≤ 10 MHz			±2	LSB
		ADL2 = "0", ADL1 = "0", CPUM7 = "0" 2.0 V ≤ VCC = VREF < 2.2 V f(XIN) = 4.4 MHz			±3	LSB
		ADL2 = "0", ADL1 = "1", CPUM7 = "0" VCC = VREF = 4.0 to 5.5 V f(XIN) = 2 × VCC MHz ≤ 10 MHz			±3	LSB
		ADL2 = "1", ADL1 = "0", CPUM7 = "1" and EXPCM0 = "1" VCC = VREF = 1.8 to 2.2 V			±4	LSB
tCONV	Conversion time	f(XIN) = 8 MHz (ADL2 = "0", ADL1 = "0", CPUM7 = "0")			TC(XIN)×100	μs
RLADDER	Ladder resistor		12	35	100	kΩ
IVREF	Reference power source input current	VREF = 5 V	50	150	200	μA
I _A	Analog port input current				5.0	μA

Table 21 A/D converter characteristics (2) (in 10 bit A/D mode)

(VCC = 1.8 to 5.5 V, Ta = -20 to 85 °C, unless otherwise noted)

Symbol	Parameter	Test conditions	Limits			Unit
			Min.	Typ.	Max.	
–	Resolution				10	Bits
ABS	Absolute accuracy (excluding quantization error)	ADL2 = "0", ADL1 = "0", CPUM7 = "0" 2.2 V ≤ VCC = VREF ≤ 5.5 V f(XIN) = 2 × VCC MHz ≤ 10 MHz			±4	LSB
		ADL2 = "0", ADL1 = "1", CPUM7 = "0" VCC = VREF = 4.0 to 5.5 V f(XIN) = 2 × VCC MHz ≤ 10 MHz			±4	LSB
		ADL2 = "1", ADL1 = "0", CPUM7 = "1" and EXPCM0 = "1" VCC = VREF = 1.8 to 2.2 V			±4	LSB
tCONV	Conversion time	f(XIN) = 8 MHz (ADL2 = "0", ADL1 = "0", CPUM7 = "0")			TC(XIN)×100	μs
RLADDER	Ladder resistor		12	35	100	kΩ
IVREF	Reference power source input current	VREF = 5 V	50	150	200	μA
I _A	Analog port input current				5.0	μA

Table 22 Timing requirements (1)

(VCC = 4.0 to 5.5 V, VSS = 0 V, Ta = -20 to 85 °C, unless otherwise noted)

Symbol	Parameter		Limits			Unit
			Min.	Typ.	Max.	
tw(RESET)	Reset input "L" pulse width		2			μs
tc(XIN)	Main clock input cycle time (XIN input)	4.0 ≤ Vcc < 4.5 V	1000/(4 × Vcc-8)			ns
		4.5 ≤ Vcc ≤ 5.5 V	100			ns
twH(XIN)	Main clock input "H" pulse width	4.0 ≤ Vcc < 4.5 V	45			ns
		4.5 ≤ Vcc ≤ 5.5 V	40			ns
twL(XIN)	Main clock input "L" pulse width	4.0 ≤ Vcc < 4.5 V	45			ns
		4.5 ≤ Vcc ≤ 5.5 V	40			ns
tc(CNTR)	CNTR0, CNTR1 input cycle time	4.0 ≤ Vcc < 4.5 V	1000/(2 × Vcc-4)			ns
		4.5 ≤ Vcc ≤ 5.5 V	200			ns
twH(CNTR)	CNTR0, CNTR1 input "H" pulse width	4.0 ≤ Vcc < 4.5 V	105			ns
		4.5 ≤ Vcc ≤ 5.5 V	85			ns
twL(CNTR)	CNTR0, CNTR1 input "L" pulse width	4.0 ≤ Vcc < 4.5 V	105			ns
		4.5 ≤ Vcc ≤ 5.5 V	85			ns
twH(INT)	INT0 to INT3 input "H" pulse width		80			ns
twL(INT)	INT0 to INT3 input "L" pulse width		80			ns
tc(SCLK)	Serial I/O clock input cycle time (Note)		800			ns
twH(SCLK)	Serial I/O clock input "H" pulse width (Note)		370			ns
twL(SCLK)	Serial I/O clock input "L" pulse width (Note)		370			ns
tsu(RxD-SCLK)	Serial I/O input set up time		220			ns
th(SCLK-RxD)	Serial I/O input hold time		100			ns

Note: When bit 6 of address 001A16 is "1" (clock synchronous).
Divide this limits value by four when bit 6 of address 001A16 is "0" (UART).

Table 23 Timing requirements (2)

(VCC = 1.8 to 4.0 V, VSS = 0 V, Ta = -20 to 85 °C, unless otherwise noted)

Symbol	Parameter		Limits			Unit
			Min.	Typ.	Max.	
tw(RESET)	Reset input "L" pulse width		2			μs
tc(XIN)	Main clock input cycle time (XIN input)	2.0 ≤ Vcc ≤ 4.0 V	125			ns
		Vcc < 2.0 V	1000/(10 × Vcc-12)			ns
twH(XIN)	Main clock input "H" pulse width	2.0 ≤ Vcc ≤ 4.0 V	50			ns
		Vcc < 2.0 V	70			ns
twL(XIN)	Main clock input "L" pulse width	2.0 ≤ Vcc ≤ 4.0 V	50			ns
		Vcc < 2.0 V	70			ns
tc(CNTR)	CNTR0, CNTR1 input cycle time	2.0 ≤ Vcc ≤ 4.0 V	1000/Vcc			ns
		Vcc < 2.0 V	1000/(5 × Vcc-8)			ns
twH(CNTR)	CNTR0, CNTR1 input "H" pulse width		tc(CNTR)/2-20			ns
twL(CNTR)	CNTR0, CNTR1 input "L" pulse width		tc(CNTR)/2-20			ns
twH(INT)	INT0 to INT3 input "H" pulse width		230			ns
twL(INT)	INT0 to INT3 input "L" pulse width		230			ns
tc(SCLK)	Serial I/O clock input cycle time (Note)		2000			ns
twH(SCLK)	Serial I/O clock input "H" pulse width (Note)		950			ns
twL(SCLK)	Serial I/O clock input "L" pulse width (Note)		950			ns
tsu(RxD-SCLK)	Serial I/O input set up time		400			ns
th(SCLK-RxD)	Serial I/O input hold time		200			ns

Note: When bit 6 of address 001A16 is "1" (clock synchronous).
Divide this limits value by four when bit 6 of address 001A16 is "0" (UART).

Table 24 Switching characteristics (1)

(VCC = 4.0 to 5.5 V, VSS = 0 V, Ta = -20 to 85 °C, unless otherwise noted)

Symbol	Parameter	Limits			Unit
		Min.	Typ.	Max.	
t _{wH} (SCLK)	Serial I/O clock output "H" pulse width	t _c (SCLK)/2-30			ns
t _{wL} (SCLK)	Serial I/O clock output "L" pulse width	t _c (SCLK)/2-30			ns
t _d (SCLK-TxD)	Serial I/O output delay time (Note)			140	ns
t _v (SCLK-TxD)	Serial I/O output valid time (Note)	-30			ns
t _r (SCLK)	Serial I/O clock output rising time			30	ns
t _f (SCLK)	Serial I/O clock output falling time			30	ns

Note : When the P45/TxD P-channel output disable bit of the UART control register (bit 4 of address 001B₁₆) is "0".**Table 25 Switching characteristics (2)**

(VCC = 1.8 to 4.0 V, VSS = 0 V, Ta = -20 to 85 °C, unless otherwise noted)

Symbol	Parameter	Limits			Unit
		Min.	Typ.	Max.	
t _{wH} (SCLK)	Serial I/O clock output "H" pulse width	t _c (SCLK)/2-100			ns
t _{wL} (SCLK)	Serial I/O clock output "L" pulse width	t _c (SCLK)/2-100			ns
t _d (SCLK-TxD)	Serial I/O output delay time (Note)			350	ns
t _v (SCLK-TxD)	Serial I/O output valid time (Note)	-30			ns
t _r (SCLK)	Serial I/O clock output rising time			100	ns
t _f (SCLK)	Serial I/O clock output falling time			100	ns

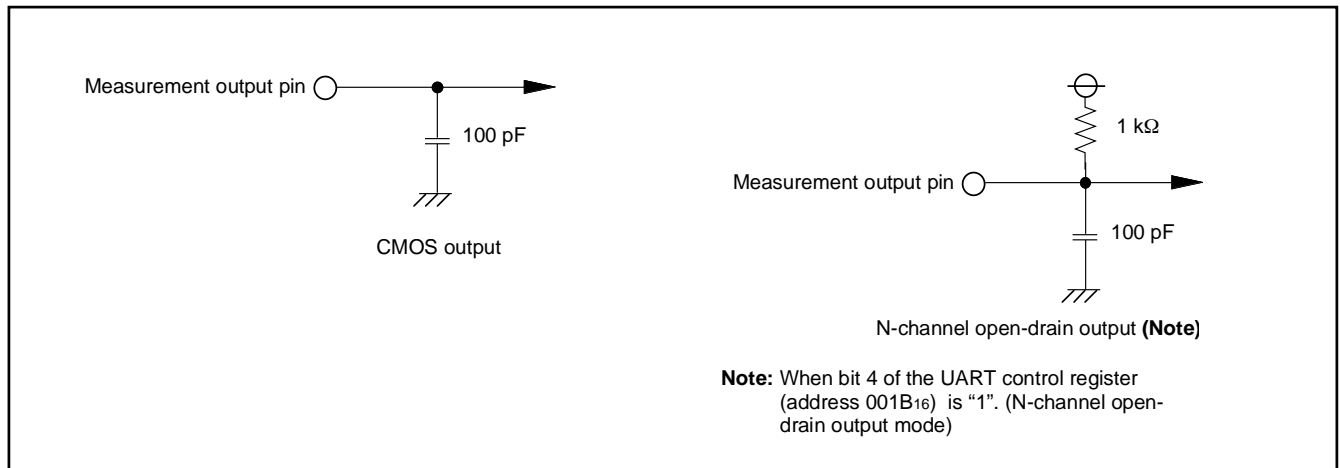
Note : When the P45/TxD P-channel output disable bit of the UART control register (bit 4 of address 001B₁₆) is "0".**Fig. 69 Circuit for measuring output switching characteristics**

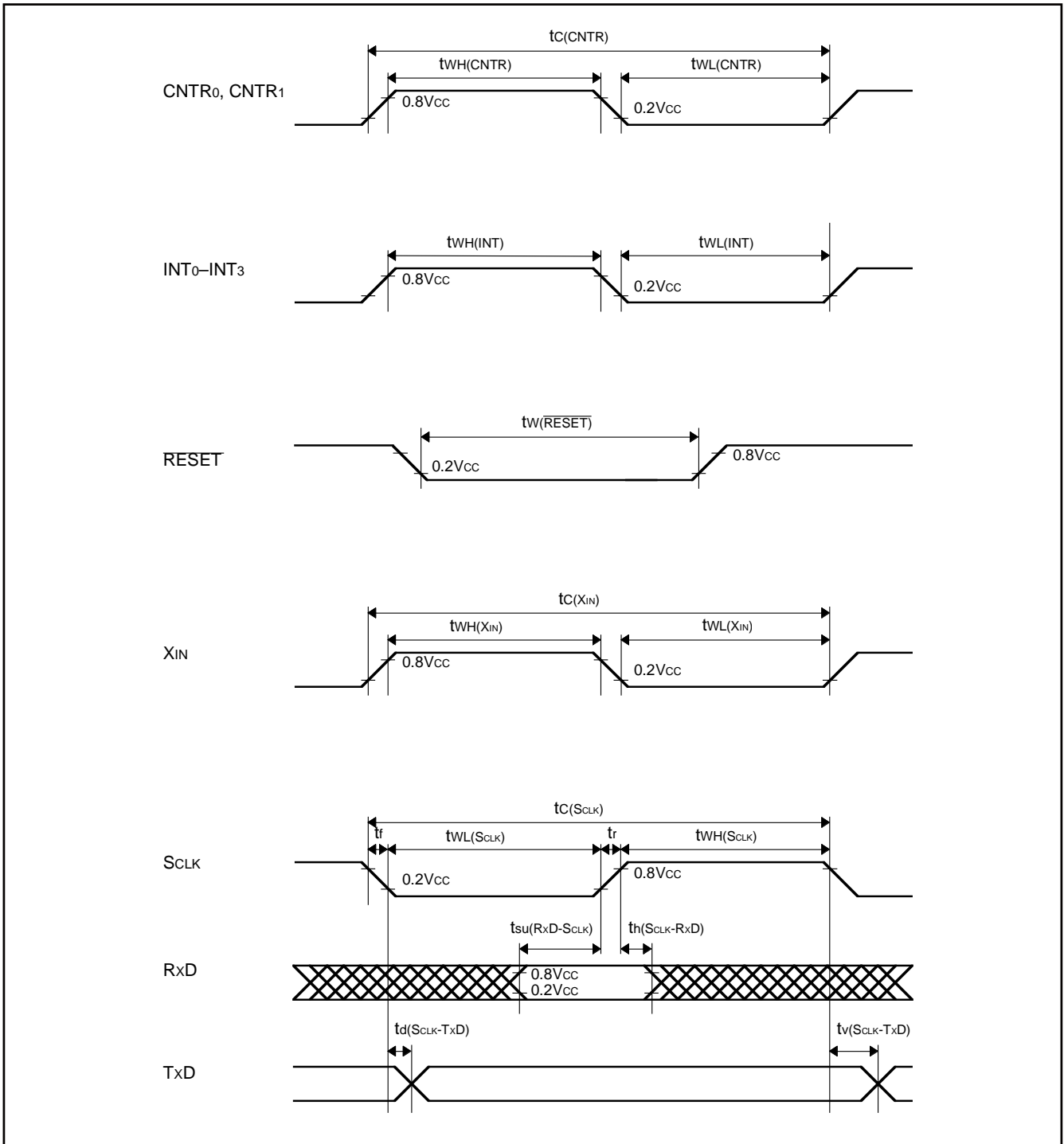
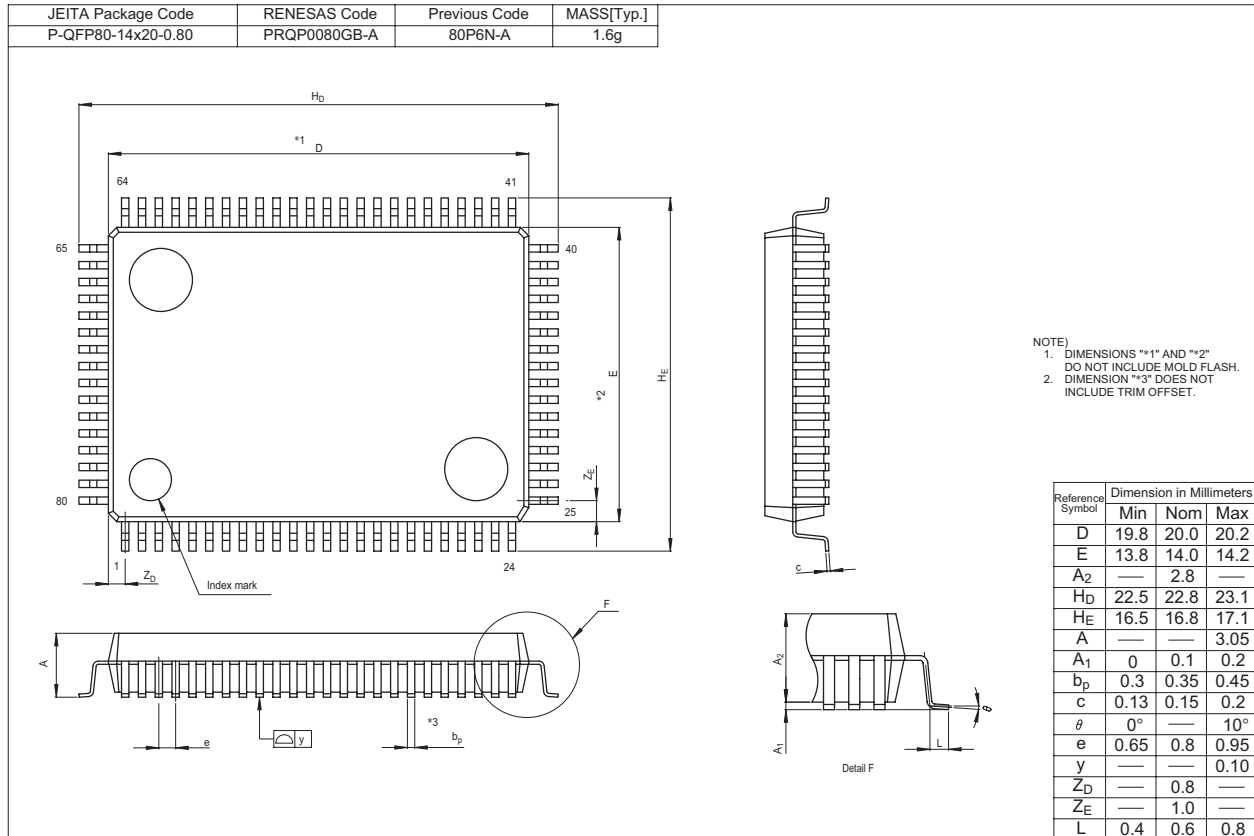
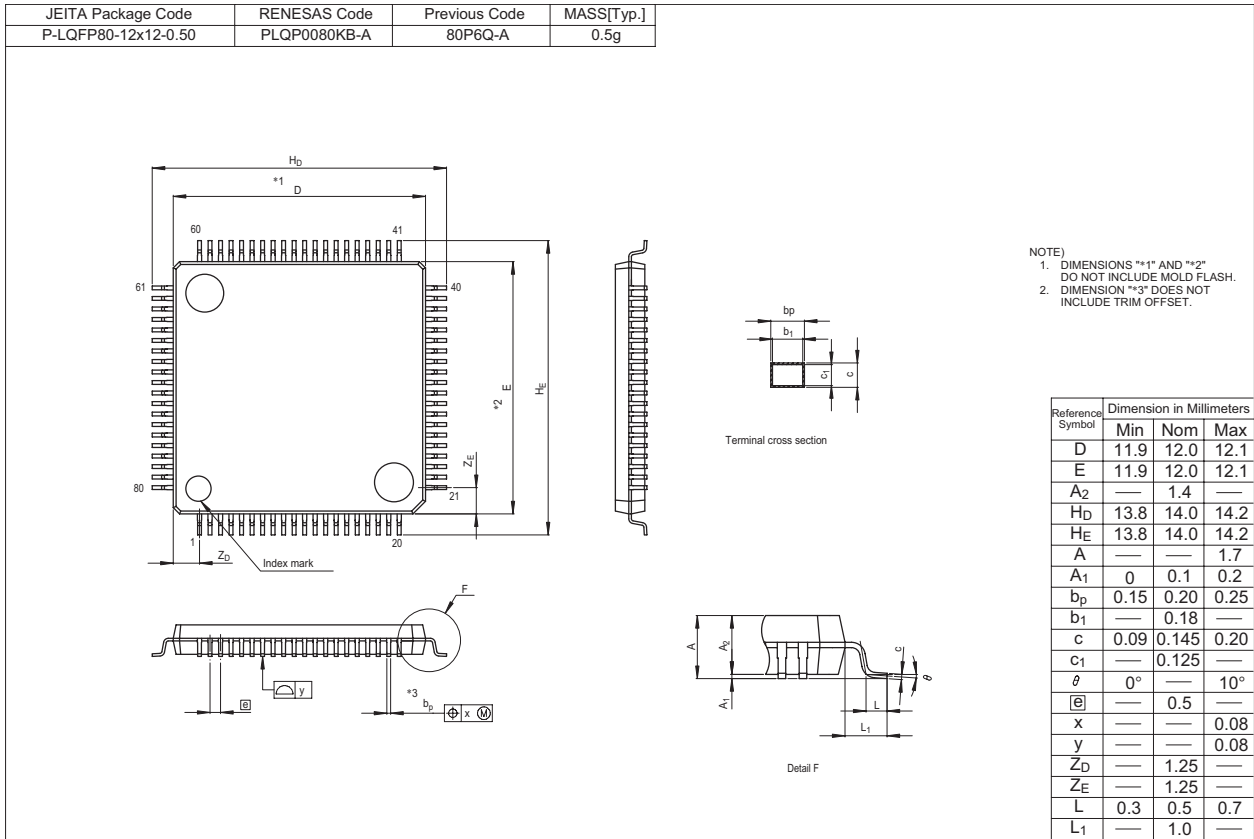

Fig. 70 Timing diagram

PACKAGE OUTLINE

Diagrams showing the latest package dimensions and mounting information are available in the “Packages” section of the Renesas Technology website.





REVISION HISTORY

3823 GROUP DATA SHEET

Rev.	Date	Description	
		Page	Summary
1.00	05/13/05		First edition
2.00	05/07/07	6 8 9 14 40 49 52 54 55 60	Table 3 is partly revised Fig.5 is partly added Table 4 is revised "ROM Code Protect Address" is added Fig.10 is revised "STP instruction Execution" is revised "Oscillation Control" (1) Stop Mode is partly revised "LCD drive Control Circuit" is revised "(6) Wiring to P40/(VPP) pin" is revised Fig.59 is revised Fig.60 is partly deleted "NOTES ON QzROM" is added Table 18 is partly added
2.01	05/11/08	6 61 65-66	Table 3 is partly revised Table 19, 20 are partly revised PACKAGE OUTLINE revised
2.02	07/06/19	- 6 8 9 10 15 22 23-27 46 48 51 52 53 54 55-58 58 59 63 66	"RENESAS TECHNICAL UPDATE" reflected: TN-740-A111A/E Table 3: Function except a port function; •Serial I/O function pins → •Serial <u>inter-</u> <u>face</u> function pins Fig. 5 M38234G4, M38235G6: Under development → Mass production Note deleted Table 4: Under development deleted FUNCTIONAL DESCRIPTION CENTRAL PROCESSING UNIT (CPU): Description added Fig. 11: Note added CPU mode <u>extension</u> register (002B16) → CPU mode <u>expansion</u> register Peripheral function <u>extension</u> register (003016) → Peripheral function <u>expansion</u> register Table 8: AVss added, Note revised INTERRUPTS: Description revised, Fig. 18-20 added ROM CORRECTION FUNCTION: Description added Initial Value of Watchdog Timer: Description added Standard Operation of Watchdog Timer: A part of description deleted Bit 6 and bit 7 of Watchdog Timer Control Register: added and revised Fig. 48 revised, Note added Fig. 53: Port P0 direction register (000016) → (000116) Frequency Control: Description revised Fig. 56: revised Fig. 57: revised QzROM Writing Mode: added Processor Status Register: added Overvoltage: Description revised and Fig. 68 added Table 15 VCC: Frequency/ <u>4</u> mode → Frequency/ <u>8</u> mode VREF: Limits Min. 2.0 → 1.8 Table 18: VRAM added

REVISION HISTORY

3823 GROUP DATA SHEET

Rev.	Date	Description	
		Page	Summary
2.02	07/06/19	67 72	Table 19 Roco: Ta = 25 °C added Note added

Notes:

1. This document is provided for reference purposes only so that Renesas customers may select the appropriate Renesas products for their use. Renesas neither makes warranties or representations with respect to the accuracy or completeness of the information contained in this document nor grants any license to any intellectual property rights or any other rights of Renesas or any third party with respect to the information in this document.
2. Renesas shall have no liability for damages or infringement of any intellectual property or other rights arising out of the use of any information in this document, including, but not limited to, product data, diagrams, charts, programs, algorithms, and application circuit examples.
3. You should not use the products or the technology described in this document for the purpose of military applications such as the development of weapons of mass destruction or for the purpose of any other military use. When exporting the products or technology described herein, you should follow the applicable export control laws and regulations, and procedures required by such laws and regulations.
4. All information included in this document such as product data, diagrams, charts, programs, algorithms, and application circuit examples, is current as of the date this document is issued. Such information, however, is subject to change without any prior notice. Before purchasing or using any Renesas products listed in this document, please confirm the latest product information with a Renesas sales office. Also, please pay regular and careful attention to additional and different information to be disclosed by Renesas such as that disclosed through our website. (<http://www.renesas.com>)
5. Renesas has used reasonable care in compiling the information included in this document, but Renesas assumes no liability whatsoever for any damages incurred as a result of errors or omissions in the information included in this document.
6. When using or otherwise relying on the information in this document, you should evaluate the information in light of the total system before deciding about the applicability of such information to the intended application. Renesas makes no representations, warranties or guarantees regarding the suitability of its products for any particular application and specifically disclaims any liability arising out of the application and use of the information in this document or Renesas products.
7. With the exception of products specified by Renesas as suitable for automobile applications, Renesas products are not designed, manufactured or tested for applications or otherwise in systems the failure or malfunction of which may cause a direct threat to human life or create a risk of human injury or which require especially high quality and reliability such as safety systems, or equipment or systems for transportation and traffic, healthcare, combustion control, aerospace and aeronautics, nuclear power, or undersea communication transmission. If you are considering the use of our products for such purposes, please contact a Renesas sales office beforehand. Renesas shall have no liability for damages arising out of the uses set forth above.
8. Notwithstanding the preceding paragraph, you should not use Renesas products for the purposes listed below:
 - (1) artificial life support devices or systems
 - (2) surgical implantations
 - (3) healthcare intervention (e.g., excision, administration of medication, etc.)
 - (4) any other purposes that pose a direct threat to human lifeRenesas shall have no liability for damages arising out of the uses set forth in the above and purchasers who elect to use Renesas products in any of the foregoing applications shall indemnify and hold harmless Renesas Technology Corp., its affiliated companies and their officers, directors, and employees against any and all damages arising out of such applications.
9. You should use the products described herein within the range specified by Renesas, especially with respect to the maximum rating, operating supply voltage range, movement power voltage range, heat radiation characteristics, installation and other product characteristics. Renesas shall have no liability for malfunctions or damages arising out of the use of Renesas products beyond such specified ranges.
10. Although Renesas endeavors to improve the quality and reliability of its products, IC products have specific characteristics such as the occurrence of failure at a certain rate and malfunctions under certain use conditions. Please be sure to implement safety measures to guard against the possibility of physical injury, and injury or damage caused by fire in the event of the failure of a Renesas product, such as safety design for hardware and software including but not limited to redundancy, fire control and malfunction prevention, appropriate treatment for aging degradation or any other applicable measures. Among others, since the evaluation of microcomputer software alone is very difficult, please evaluate the safety of the final products or system manufactured by you.
11. In case Renesas products listed in this document are detached from the products to which the Renesas products are attached or affixed, the risk of accident such as swallowing by infants and small children is very high. You should implement safety measures so that Renesas products may not be easily detached from your products. Renesas shall have no liability for damages arising out of such detachment.
12. This document may not be reproduced or duplicated, in any form, in whole or in part, without prior written approval from Renesas.
13. Please contact a Renesas sales office if you have any questions regarding the information contained in this document, Renesas semiconductor products, or if you have any other inquiries.



RENESAS SALES OFFICES

<http://www.renesas.com>

Refer to "<http://www.renesas.com/en/network>" for the latest and detailed information.

Renesas Technology America, Inc.
450 Holger Way, San Jose, CA 95134-1368, U.S.A
Tel: <1> (408) 382-7500, Fax: <1> (408) 382-7501

Renesas Technology Europe Limited
Dukes Meadow, Millboard Road, Bourne End, Buckinghamshire, SL8 5FH, U.K.
Tel: <44> (1628) 585-100, Fax: <44> (1628) 585-900

Renesas Technology (Shanghai) Co., Ltd.
Unit 204, 205, AZIACenter, No.1233 Lujiazui Ring Rd, Pudong District, Shanghai, China 200120
Tel: <86> (21) 5877-1818, Fax: <86> (21) 6887-7898

Renesas Technology Hong Kong Ltd.
7th Floor, North Tower, World Finance Centre, Harbour City, 1 Canton Road, Tsimshatsui, Kowloon, Hong Kong
Tel: <852> 2265-6688, Fax: <852> 2730-6071

Renesas Technology Taiwan Co., Ltd.
10th Floor, No.99, Fushing North Road, Taipei, Taiwan
Tel: <886> (2) 2715-2888, Fax: <886> (2) 2713-2999

Renesas Technology Singapore Pte. Ltd.
1 Harbour Front Avenue, #06-10, Keppel Bay Tower, Singapore 098632
Tel: <65> 6213-0200, Fax: <65> 6278-8001

Renesas Technology Korea Co., Ltd.
Kukje Center Bldg. 18th Fl., 191, 2-ka, Hangang-ro, Yongsan-ku, Seoul 140-702, Korea
Tel: <82> (2) 796-3115, Fax: <82> (2) 796-2145

Renesas Technology Malaysia Sdn. Bhd
Unit 906, Block B, Menara Amcorp, Amcorp Trade Centre, No.18, Jalan Persiaran Barat, 46050 Petaling Jaya, Selangor Darul Ehsan, Malaysia
Tel: <603> 7955-9390, Fax: <603> 7955-9510

Looking for pricing, stock, or lifecycle information?

Click below to explore more details on WIN SOURCE:

- [View M38239GCFP on WIN SOURCE](#)
- [Renesas Electronics America Information](#)

Optimize Your Supply Chain with WIN SOURCE Solutions

- ✓ Global Sourcing Solution
- ✓ Obsolete Management
- ✓ Cost Control Management
- ✓ Shortage Management
- ✓ Alternative Solution
- ✓ Excess Inventory Management