



**THE DATASHEET OF
M34E02-FMB1TG**



2-Kbit serial presence detect (SPD) EEPROM for double data rate (DDR1, DDR2 and DDR3) DRAM modules

Datasheet - production data



UFDFPN8 (MC)
2 x 3 mm

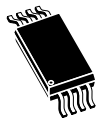

TSSOP8 (DW)
4.4 x 3 mm

Features

- 2-Kbit EEPROM for DDR1, DDR2 and DDR3 serial presence detect
- Backward compatible with the M34C02
- Permanent and reversible software data protection for lower 128 bytes
- 100 kHz and 400 kHz I²C bus serial interface
- Single supply voltage:
 - 1.7 V to 5.5 V
- Byte and Page Write (up to 16 bytes)
- Self-timed write cycle
- Noise filtering
 - Schmitt trigger on bus inputs
 - Noise filter on bus inputs
- Enhanced ESD/latch-up protection
- More than 1 million erase/write cycles
- More than 40 years' data retention
- ECOPACK[®] (RoHS compliant) packages
- Packages:
 - ECOPACK2[®] (RoHS-compliant and Halogen-free)

Contents

1	Description	6
2	Signal description	8
2.1	Serial Clock (SCL)	8
2.2	Serial Data (SDA)	8
2.3	Chip Enable (E0, E1, E2)	8
2.4	Write Control (\overline{WC})	9
2.5	Supply voltage (V_{CC})	9
2.5.1	Operating supply voltage (V_{CC})	9
2.5.2	Power-up conditions	9
2.5.3	Device reset	9
2.5.4	Power-down conditions	10
3	Device operation	12
3.1	Start condition	12
3.2	Stop condition	12
3.3	Acknowledge bit (ACK)	12
3.4	Data input	12
3.5	Memory addressing	13
3.6	Setting the write-protection	14
3.6.1	SWP and CWP	14
3.6.2	PSWP	14
3.7	Write operations	15
3.7.1	Byte Write	15
3.7.2	Page Write	15
3.7.3	Minimizing system delays by polling on ACK	17
3.8	Read operations	17
3.8.1	Random Address Read	17
3.8.2	Current Address Read	17
3.8.3	Sequential Read	17
3.8.4	Acknowledge in Read mode	18
4	Initial delivery state	19

5	Use within a DDR1/DDR2/DDR3 DRAM module	19
5.1	Programming the M34E02-F	19
5.1.1	Isolated DRAM module	19
5.1.2	DRAM module inserted in the application motherboard	20
6	Maximum rating	23
7	DC and AC parameters	24
8	Package mechanical data	29
9	Part numbering	32
10	Revision history	33

List of tables

Table 1.	Signal names	7
Table 2.	Device select code	11
Table 3.	Operating modes	13
Table 4.	DRAM DIMM connections	19
Table 5.	Acknowledge when writing data or defining the write-protection (instructions with R/W bit = 0)	20
Table 6.	Acknowledge when reading the write protection ((instructions with R/W bit = 1)	21
Table 7.	Absolute maximum ratings	23
Table 8.	Operating conditions (for temperature range 1 devices)	24
Table 9.	Operating conditions (for temperature range 6 devices)	24
Table 10.	AC measurement conditions.	24
Table 11.	Input parameters.	25
Table 12.	DC characteristics (for temperature range 1 devices)	25
Table 13.	DC characteristics (for temperature range 6 devices)	26
Table 14.	AC characteristics	27
Table 15.	UFDFPN8 (MLP8) – 8-lead ultra thin fine pitch dual flat package no lead 2 x 3 mm, data	30
Table 16.	TSSOP8 – 8-lead thin shrink small outline, package mechanical data.	31
Table 17.	Ordering information scheme	32
Table 18.	Document revision history	33

List of figures

Figure 1.	Logic diagram	6
Figure 2.	TSSOP and MLP connections (top view)	7
Figure 3.	Device select code	8
Figure 4.	Maximum R_P value versus bus parasitic capacitance (C) for an I ² C bus	10
Figure 5.	I ² C bus protocol	10
Figure 6.	Result of setting the write protection	13
Figure 7.	Setting the write protection ($\overline{WC} = 0$)	14
Figure 8.	Write mode sequences in a non write-protected area	16
Figure 9.	Write cycle polling flowchart using ACK	16
Figure 10.	Read mode sequences	18
Figure 11.	Serial presence detect block diagram	22
Figure 12.	AC measurement I/O waveform	24
Figure 13.	AC waveforms	28
Figure 14.	UFDFPN8 (MLP8) – 8-lead ultra thin fine pitch dual flat package no lead 2 x 3 mm, outline	30
Figure 15.	TSSOP8 – 8-lead thin shrink small outline, package outline	31

1 Description

The M34E02-F is a 2-Kbit I²C-compatible EEPROM (Electrically Erasable PROgrammable Memory) organized as 256 × 8 bits.

The M34E02-F can be accessed with a supply voltage from 1.7 V to 5.5 V and operates with a clock frequency of 400 kHz (or less), over an ambient temperature range of -40 °C / +85 °C.

Figure 1. Logic diagram

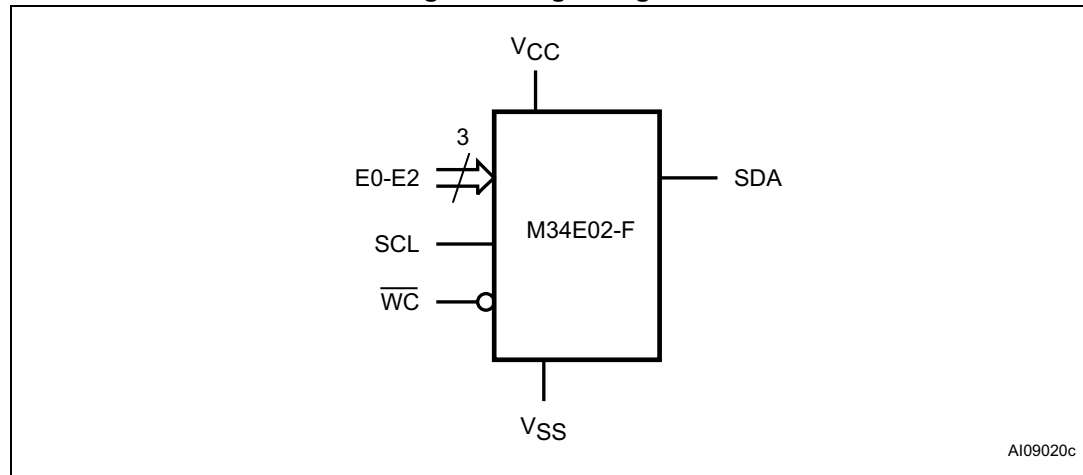

The M34E02-F is able to lock permanently the data in its first half (from location 00h to 7Fh). This facility has been designed specifically for use in DRAM DIMMs (dual interline memory modules) with serial presence detect (SPD). All the information concerning the DDR1, DDR2 or DDR3 configuration of the DRAM module (such as its access speed, size and organization) can be kept write-protected in the first half of the memory.

The first half of the memory area can be write-protected using two different software write protection mechanisms. By sending the device a specific sequence, the first 128 bytes of the memory become write protected: permanently or resettable. In addition, the devices allow the entire memory area to be write protected, using the \overline{WC} input (for example by tying this input to V_{CC}).

These I²C-compatible electrically erasable programmable memory (EEPROM) devices are organized as 256 × 8 bits.

I²C uses a two wire serial interface, comprising a bi-directional data line and a clock line. The devices carry a built-in 4-bit device type identifier code (1010) in accordance with the I²C bus definition to access the memory area and a second device type identifier code (0110) to define the protection. These codes are used together with the voltage level applied on the three chip enable inputs (E2, E1, E0).

The devices behave as a slave device in the I²C protocol, with all memory operations synchronized by the serial clock. Read and Write operations are initiated by a Start condition, generated by the bus master. The Start condition is followed by a device select code and RW bit (as described in the Device select code table), terminated by an acknowledge bit.

When writing data to the memory, the memory inserts an acknowledge bit during the 9th bit time, following the bus master's 8-bit transmission. When data is read by the bus master,

the bus master acknowledges the receipt of the data byte in the same way. Data transfers are terminated by a Stop condition after an Ack for WRITE, and after a NoAck for READ.

Figure 2. TSSOP and MLP connections (top view)

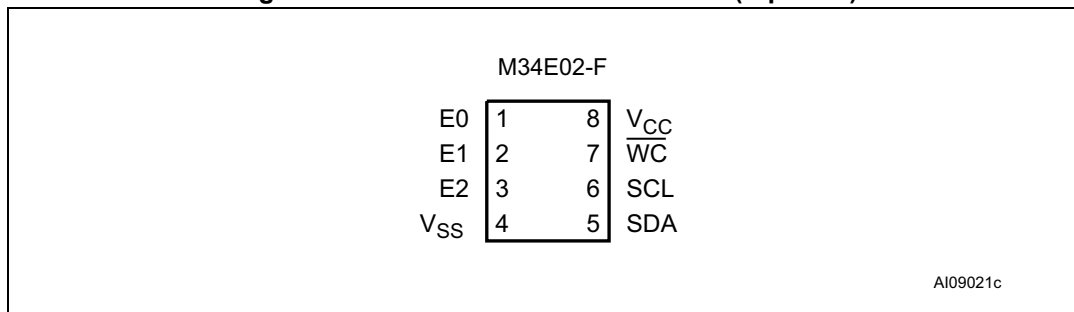

1. See [Section 8: Package mechanical data](#) for package dimensions, and how to identify pin-1.

Table 1. Signal names

Signal names	Description
E0, E1, E2	Chip Enable
SDA	Serial Data
SCL	Serial Clock
\overline{WC}	Write Control
V _{CC}	Supply voltage
V _{SS}	Ground

2 Signal description

2.1 Serial Clock (SCL)

This input signal is used to strobe all data in and out of the device. In applications where this signal is used by slave devices to synchronize the bus to a slower clock, the bus master must have an open drain output, and a pull-up resistor can be connected from Serial Clock (SCL) to V_{CC} . (Figure 4 indicates how the value of the pull-up resistor can be calculated). In most applications, though, this method of synchronization is not employed, and so the pull-up resistor is not necessary, provided that the bus master has a push-pull (rather than open drain) output.

2.2 Serial Data (SDA)

This bidirectional signal is used to transfer data in or out of the device. It is an open drain output that may be wire-OR'ed with other open drain or open collector signals on the bus. A pull up resistor must be connected from Serial Data (SDA) to V_{CC} . (Figure 4 indicates how the value of the pull-up resistor can be calculated).

2.3 Chip Enable (E0, E1, E2)

These input signals are used to set the value that is to be looked for on the three least significant bits (b3, b2, b1) of the 7-bit device select code. In the end application, E0, E1 and E2 must be directly (not through a pull-up or pull-down resistor) connected to V_{CC} or V_{SS} to establish the device select code. When these inputs are not connected, an internal pull-down circuitry makes (E0,E1,E2) = (0,0,0).

The E0 input is used to detect the V_{HV} voltage, when decoding an SWP or CWP instruction.

Figure 3. Device select code

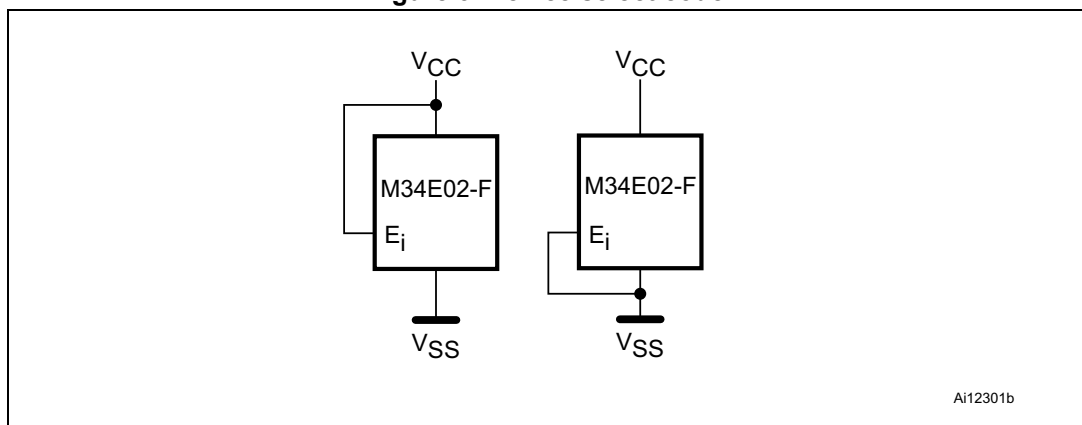

2.4 Write Control (\overline{WC})

This input signal is provided for protecting the contents of the whole memory from inadvertent write operations. Write Control (\overline{WC}) is used to enable (when driven low) or disable (when driven high) write instructions to the entire memory area or to the Protection Register.

When Write Control (\overline{WC}) is tied low or left unconnected, the write protection of the first half of the memory is determined by the status of the Protection Register.

2.5 Supply voltage (V_{CC})

2.5.1 Operating supply voltage (V_{CC})

Prior to selecting the memory and issuing instructions to it, a valid and stable V_{CC} voltage within the specified [$V_{CC}(\min)$, $V_{CC}(\max)$] range must be applied (see [Table 8](#)). In order to secure a stable DC supply voltage, it is recommended to decouple the V_{CC} line with a suitable capacitor (usually of the order of 10 nF to 100 nF) close to the V_{CC}/V_{SS} package pins.

This voltage must remain stable and valid until the end of the transmission of the instruction and, for a Write instruction, until the completion of the internal write cycle (t_W).

2.5.2 Power-up conditions

The V_{CC} voltage has to rise continuously from 0 V up to the minimum V_{CC} operating voltage defined in [Table 8](#) and the rise time must not vary faster than 1 V/ μ s.

2.5.3 Device reset

In order to prevent inadvertent write operations during power-up, a power-on reset (POR) circuit is included. At power-up, the device does not respond to any instruction until V_{CC} reaches the internal reset threshold voltage (this threshold is lower than the minimum V_{CC} operating voltage defined in [Table 8](#)).

When V_{CC} passes over the POR threshold, the device is reset and enters the Standby Power mode. However, the device must not be accessed until V_{CC} reaches a valid and stable V_{CC} voltage within the specified [$V_{CC}(\min)$, $V_{CC}(\max)$] range.

In a similar way, during power-down (continuous decrease in V_{CC}), as soon as V_{CC} drops below the power-on reset threshold voltage, the device stops responding to any instruction sent to it.

2.5.4 Power-down conditions

During power-down (continuous decrease in V_{CC}), the device must be in Standby Power mode (mode reached after decoding a Stop condition, assuming that there is no internal write cycle in progress).

Figure 4. Maximum R_p value versus bus parasitic capacitance (C) for an I²C bus

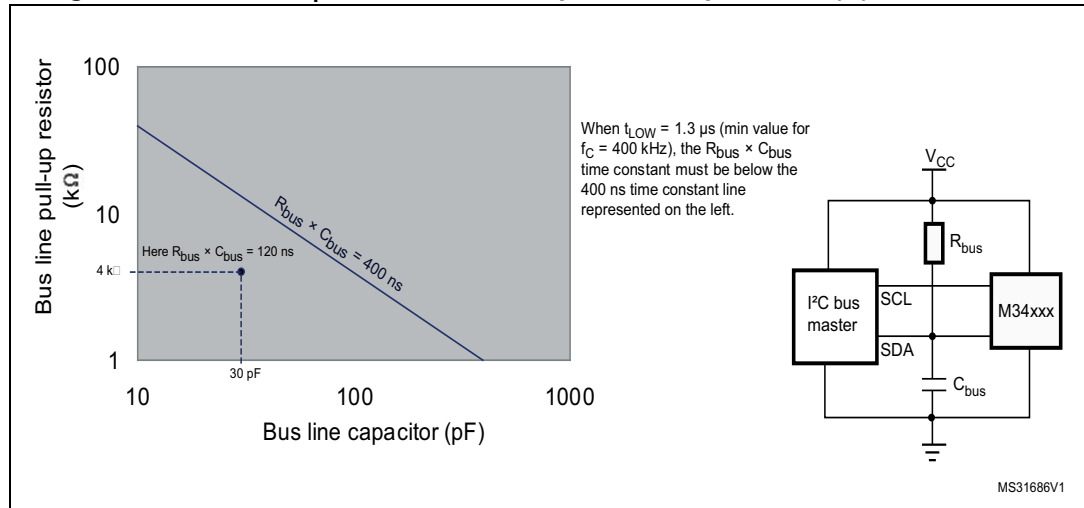

Figure 5. I²C bus protocol

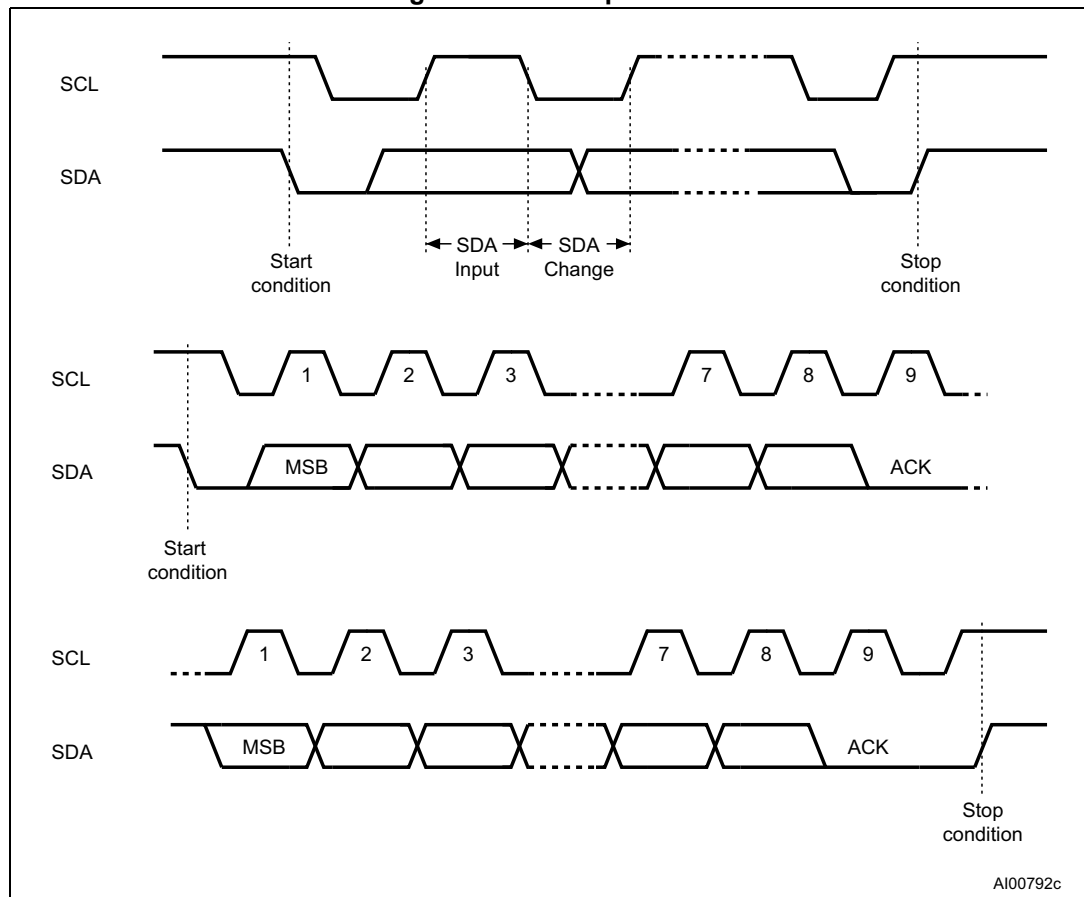

Table 2. Device select code

	Chip Enable signals			Device type identifier				Chip Enable bits			\overline{RW}
				b7 ⁽¹⁾	b6	b5	b4	b3	b2	b1	b0
Memory area select code (two arrays) ⁽²⁾	E2	E1	E0	1	0	1	0	E2	E1	E0	\overline{RW}
Set write protection (SWP)	V _{SS}	V _{SS}	V _{HV} ⁽³⁾	0	1	1	0	0	0	1	0
Clear write protection (CWP)	V _{SS}	V _{CC}	V _{HV} ⁽³⁾					0	1	1	0
Permanently set write protection (PSWP) ⁽²⁾	E2	E1	E0					E2	E1	E0	0
Read SWP	V _{SS}	V _{SS}	V _{HV} ⁽³⁾					0	0	1	1
Read CWP	V _{SS}	V _{CC}	V _{HV} ⁽³⁾					0	1	1	1
Read PSWP ⁽²⁾	E2	E1	E0					E2	E1	E0	1

1. The most significant bit, b7, is sent first.
2. E0, E1 and E2 are compared against the respective external pins on the memory device.
3. V_{HV} is defined in [Table 13](#).

3 Device operation

The device supports the I²C protocol. This is summarized in [Figure 5](#). Any device that sends data on to the bus is defined to be a transmitter, and any device that reads the data to be a receiver. The device that controls the data transfer is known as the bus master, and the other as the slave device. A data transfer can only be initiated by the bus master, which will also provide the serial clock for synchronization. The memory device is always a slave in all communication.

3.1 Start condition

Start is identified by a falling edge of Serial Data (SDA) while Serial Clock (SCL) is stable in the high state. A Start condition must precede any data transfer command. The device continuously monitors (except during a Write cycle) Serial Data (SDA) and Serial Clock (SCL) for a Start condition.

3.2 Stop condition

Stop is identified by a rising edge of Serial Data (SDA) while Serial Clock (SCL) is stable and driven high. A Stop condition terminates communication between the device and the bus master. A Read command that is followed by NoAck can be followed by a Stop condition to force the device into the Standby mode. A Stop condition at the end of a Write command triggers the internal EEPROM Write cycle.

3.3 Acknowledge bit (ACK)

The acknowledge bit is used to indicate a successful byte transfer. The bus transmitter, whether it be bus master or slave device, releases Serial Data (SDA) after sending eight bits of data. During the 9th clock pulse period, the receiver pulls Serial Data (SDA) low to acknowledge the receipt of the eight data bits.

3.4 Data input

During data input, the device samples Serial Data (SDA) on the rising edge of Serial Clock (SCL). For correct device operation, Serial Data (SDA) must be stable during the rising edge of Serial Clock (SCL), and the Serial Data (SDA) signal must change *only* when Serial Clock (SCL) is driven low.

3.5 Memory addressing

To start communication between the bus master and the slave device, the bus master must initiate a Start condition. Following this, the bus master sends the device select code, shown in [Table 2](#) (on Serial Data (SDA), most significant bit first).

The device select code consists of a 4-bit device type identifier, and a 3-bit Chip Enable "Address" (E2, E1, E0). To address the memory array, the 4-bit device type identifier is 1010b; to access the write-protection settings, it is 0110b.

Up to eight memory devices can be connected on a single I²C bus. Each one is given a unique 3-bit code on the Chip Enable (E0, E1, E2) inputs. When the device select code is received, the device only responds if the Chip Enable address is the same as the value on the Chip Enable (E0, E1, E2) inputs.

The 8th bit is the Read/Write bit (\overline{RW}). This bit is set to 1 for Read and 0 for Write operations.

If a match occurs on the device select code, the corresponding device gives an acknowledgment on Serial Data (SDA) during the 9th bit time. If the device does not match the device select code, it deselects itself from the bus, and goes into Standby mode.

Table 3. Operating modes

Mode	\overline{RW} bit	$\overline{WC}^{(1)}$	Bytes	Initial Sequence
Current Address Read	1	X	1	Start, Device Select, $\overline{RW} = 1$
Random Address Read	0	X	1	Start, Device Select, $\overline{RW} = 0$, Address
	1	X		reStart, Device Select, $\overline{RW} = 1$
Sequential Read	1	X	≥ 1	Similar to Current or Random Address Read
Byte Write	0	V_{IL}	1	Start, Device Select, $\overline{RW} = 0$
Page Write	0	V_{IL}	≤ 16	Start, Device Select, $\overline{RW} = 0$

1. X = V_{IH} or V_{IL} .

Figure 6. Result of setting the write protection

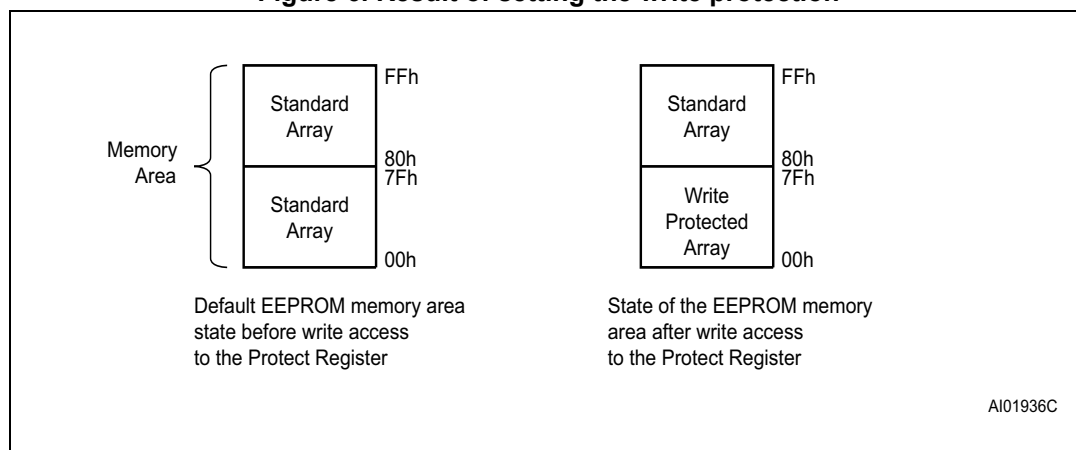

3.6 Setting the write-protection

The M34E02-F has a hardware write-protection feature, using the Write Control (\overline{WC}) signal. This signal can be driven high or low, and must be held constant for the whole instruction sequence. When Write Control (\overline{WC}) is held high, the whole memory array (addresses 00h to FFh) is write protected. When Write Control (\overline{WC}) is held low, the write protection of the memory array is dependent on whether software write-protection has been set.

Software write-protection allows the bottom half of the memory area (addresses 00h to 7Fh) to be write protected irrespective of subsequent states of the Write Control (\overline{WC}) signal.

Software write-protection is handled by three instructions:

- SWP: Set Write Protection
- CWP: Clear Write Protection
- PSWP: Permanently Set Write Protection

The level of write-protection (set or cleared) that has been defined using these instructions, remains defined even after a power cycle.

3.6.1 SWP and CWP

If the software write-protection has been set with the SWP instruction, it can be cleared again with a CWP instruction.

The two instructions (SWP and CWP) have the same format as a Byte Write instruction, but with a different device type identifier (as shown in [Table 2](#)). Like the Byte Write instruction, it is followed by an address byte and a data byte, but in this case the contents are all “Don’t Care” ([Figure 7](#)). Another difference is that the voltage, V_{HV} , must be applied on the E0 pin, and specific logical levels must be applied on the other two (E1 and E2, as shown in [Table 2](#)).

3.6.2 PSWP

If the software write-protection has been set with the PSWP instruction, the first 128 bytes of the memory are permanently write-protected. This write-protection cannot be cleared by any instruction, or by power-cycling the device, and regardless the state of Write Control (\overline{WC}). Also, once the PSWP instruction has been successfully executed, the M34E02-F no longer acknowledges any instruction (with a device type identifier of 0110) to access the write-protection settings.

Figure 7. Setting the write protection ($\overline{WC} = 0$)

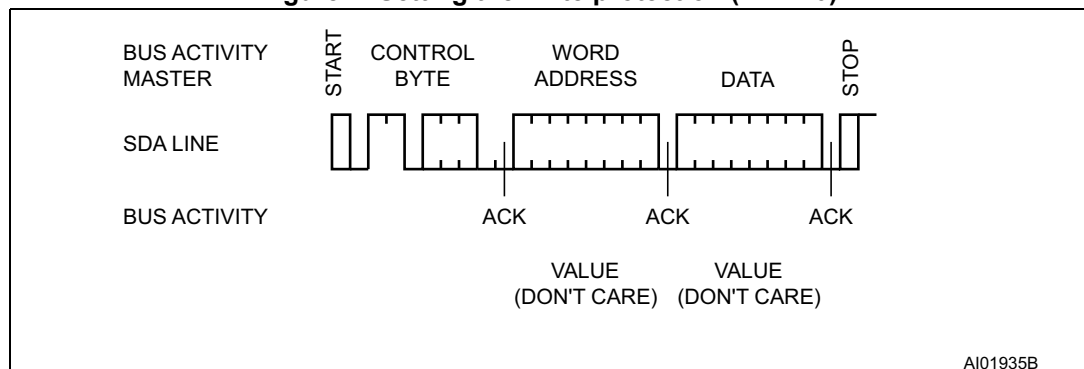

3.7 Write operations

Following a Start condition the bus master sends a device select code with the \overline{RW} bit reset to 0. The device acknowledges this, as shown in [Figure 8](#), and waits for an address byte. The device responds to the address byte with an acknowledge bit, and then waits for the data byte.

When the bus master generates a Stop condition immediately after a data byte Ack bit (in the “10th bit” time slot), either at the end of a Byte Write or a Page Write, the internal memory Write cycle is triggered. A Stop condition at any other time slot does not trigger the internal Write cycle.

During the internal Write cycle, Serial Data (SDA) and Serial Clock (SCL) are ignored, and the device does not respond to any requests.

3.7.1 Byte Write

After the device select code and the address byte, the bus master sends one data byte. If the addressed location is hardware write-protected, the device replies to the data byte with NoAck, and the location is not modified. If, instead, the addressed location is not Write-protected, the device replies with Ack. The bus master terminates the transfer by generating a Stop condition, as shown in [Figure 8](#).

3.7.2 Page Write

The Page Write mode allows up to 16 bytes to be written in a single Write cycle, provided that they are all located in the same page in the memory: that is, the most significant memory address bits are the same. If more bytes are sent than will fit up to the end of the page, a condition known as ‘roll-over’ occurs. This should be avoided, as data starts to become overwritten in an implementation dependent way.

The bus master sends from 1 to 16 bytes of data, each of which is acknowledged by the device if Write Control (\overline{WC}) is low. If the addressed location is hardware write-protected, the device replies to the data byte with NoAck, and the locations are not modified. After each byte is transferred, the internal byte address counter (the 4 least significant address bits only) is incremented. The transfer is terminated by the bus master generating a Stop condition.

Figure 8. Write mode sequences in a non write-protected area

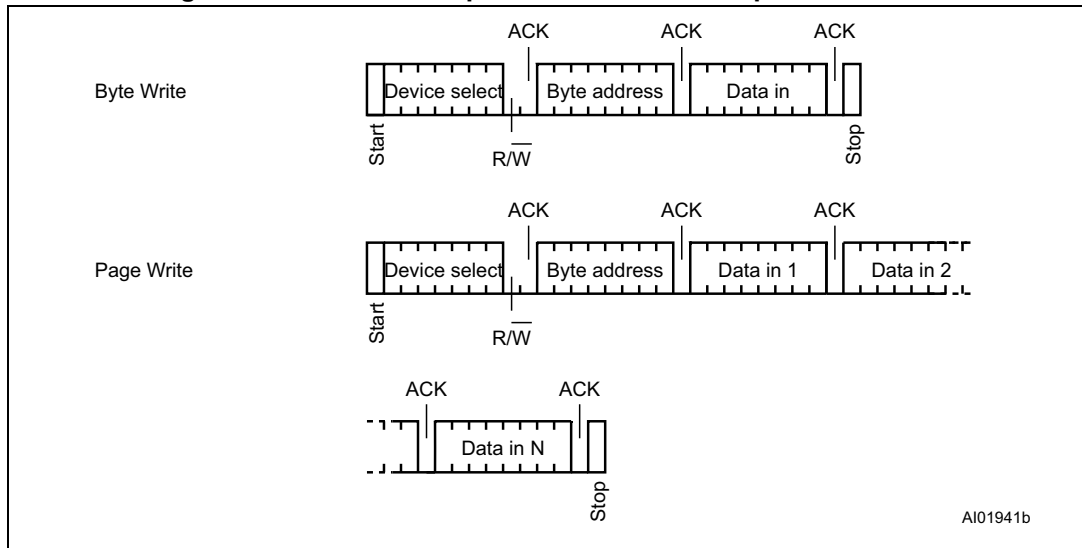

AI01941b

Figure 9. Write cycle polling flowchart using ACK

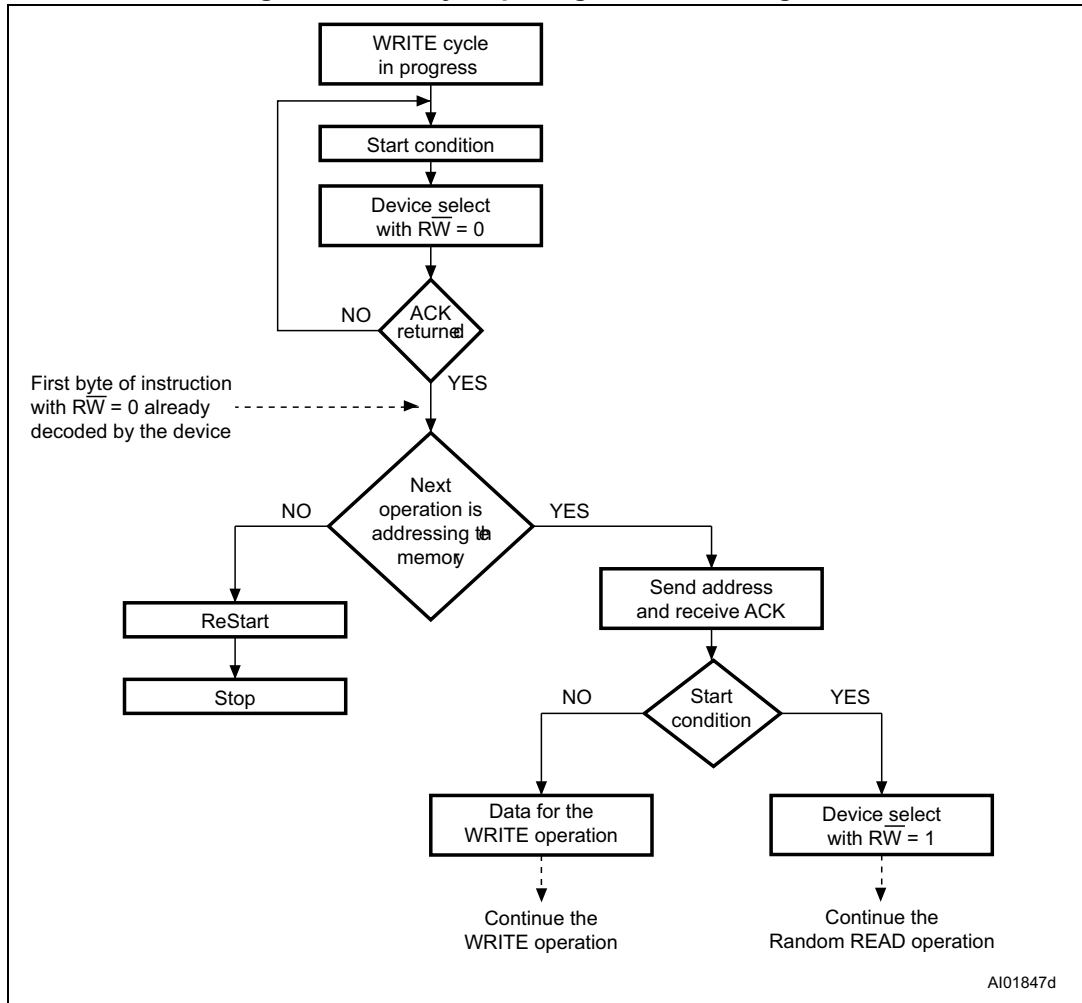

AI01847d

3.7.3 Minimizing system delays by polling on ACK

During the internal Write cycle, the device disconnects itself from the bus, and writes a copy of the data from its internal latches to the memory cells. The maximum Write time (t_w) is shown in [Table 14](#), but the typical time is shorter. To make use of this, a polling sequence can be used by the bus master.

The sequence, as shown in [Figure 9](#), is:

- Initial condition: a Write cycle is in progress.
- Step 1: the bus master issues a Start condition followed by a device select code (the first byte of the new instruction).
- Step 2: if the device is busy with the internal Write cycle, no Ack will be returned and the bus master goes back to Step 1. If the device has terminated the internal Write cycle, it responds with an Ack, indicating that the device is ready to receive the second part of the instruction (the first byte of this instruction having been sent during Step 1).

3.8 Read operations

Read operations are performed independently of whether hardware or software protection has been set.

The device has an internal address counter which is incremented each time a byte is read.

3.8.1 Random Address Read

A dummy Write is first performed to load the address into this address counter (as shown in [Figure 10](#)) but *without* sending a Stop condition. Then, the bus master sends another Start condition, and repeats the device select code, with the \overline{RW} bit set to 1. The device acknowledges this, and outputs the contents of the addressed byte. The bus master must *not* acknowledge the byte, and terminates the transfer with a Stop condition.

3.8.2 Current Address Read

For the Current Address Read operation, following a Start condition, the bus master only sends a device select code with the \overline{RW} bit set to 1. The device acknowledges this, and outputs the byte addressed by the internal address counter. The counter is then incremented. The bus master terminates the transfer with a Stop condition, as shown in [Figure 10](#), *without* acknowledging the byte.

3.8.3 Sequential Read

This operation can be used after a Current Address Read or a Random Address Read. The bus master *does* acknowledge the data byte output, and sends additional clock pulses so that the device continues to output the next byte in sequence. To terminate the stream of bytes, the bus master must *not* acknowledge the last byte, and *must* generate a Stop condition, as shown in [Figure 10](#).

The output data comes from consecutive addresses, with the internal address counter automatically incremented after each byte output. After the last memory address, the address counter 'rolls-over', and the device continues to output data from memory address 00h.

3.8.4 Acknowledge in Read mode

For all Read commands, the device waits, after each byte read, for an acknowledgment during the 9th bit time. If the bus master does not drive Serial Data (SDA) low during this time, the device terminates the data transfer and switches to its Standby mode.

Figure 10. Read mode sequences

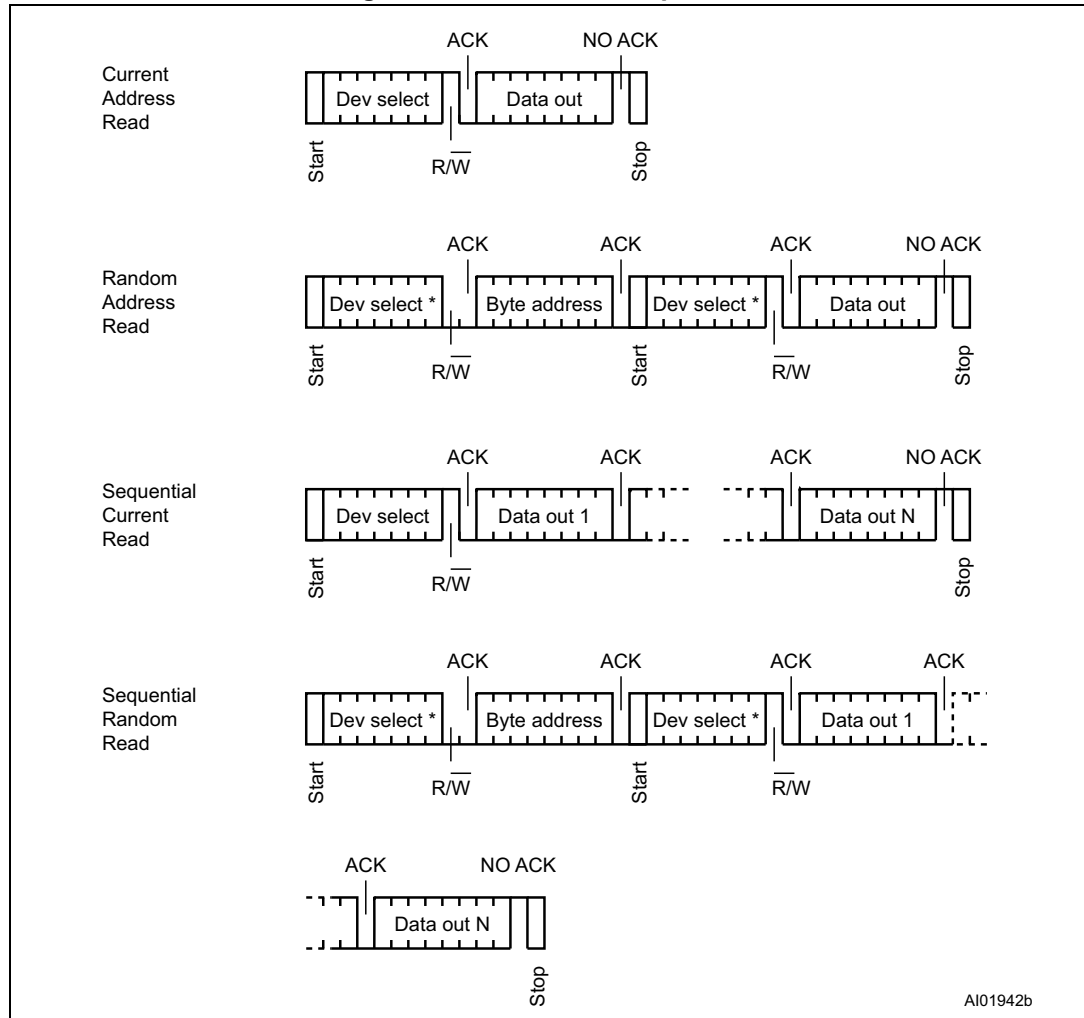

1. The seven most significant bits of the device select code of a Random Read (in the 1st and 3rd bytes) must be identical.

4 Initial delivery state

The device is delivered with all bits in the memory array set to '1' (each Byte contains FFh).

5 Use within a DDR1/DDR2/DDR3 DRAM module

In the application, the M34E02-F is soldered directly in the printed circuit module. The three Chip Enable inputs (E0, E1, E2) must be connected to V_{SS} or V_{CC} directly (that is without using a pull-up or pull-down resistor) through the DIMM socket (see [Table 4](#)). The pull-up resistors needed for normal behavior of the I²C bus are connected on the I²C bus of the mother-board (as shown in [Figure 11](#)).

The Write Control (\overline{WC}) of the M34E02-F can be left unconnected. However, connecting it to V_{SS} is recommended, to maintain full read and write access.

Table 4. DRAM DIMM connections

DIMM position	E2	E1	E0
0	V_{SS}	V_{SS}	V_{SS}
1	V_{SS}	V_{SS}	V_{CC}
2	V_{SS}	V_{CC}	V_{SS}
3	V_{SS}	V_{CC}	V_{CC}
4	V_{CC}	V_{SS}	V_{SS}
5	V_{CC}	V_{SS}	V_{CC}
6	V_{CC}	V_{CC}	V_{SS}
7	V_{CC}	V_{CC}	V_{CC}

5.1 Programming the M34E02-F

The situations in which the M34E02-F is programmed can be considered under two headings:

- when the DDR DRAM is isolated (not inserted on the PCB motherboard)
- when the DDR DRAM is inserted on the PCB motherboard

5.1.1 Isolated DRAM module

With specific programming equipment, it is possible to define the M34E02-F content, using Byte and Page Write instructions, and its write-protection using the SWP and CWP instructions. To issue the SWP and CWP instructions, the DRAM module must be inserted in a specific slot where the E0 signal can be driven to V_{HV} during the whole instruction. This programming step is mainly intended for use by DRAM module makers, whose end application manufacturers will want to clear this write-protection with the CWP on their own specific programming equipment, to modify the lower 128 Bytes, and finally to set permanently the write-protection with the PSWP instruction.

5.1.2 DRAM module inserted in the application motherboard

As the final application cannot drive the E0 pin to V_{HV} , the only possible action is to freeze the write-protection with the PSWP instruction.

Table 5 and Table 6 show how the Ack bits can be used to identify the write-protection status.

Table 5. Acknowledge when writing data or defining the write-protection (instructions with R/W bit = 0)

Status	\overline{WC} input level	Instruction	Ack	Address	Ack	Data byte	Ack	Write cycle (t_w)
Permanently protected	X	PSWP, SWP or CWP	NoAck	Not significant	NoAck	Not significant	NoAck	No
		Page or Byte Write in lower 128 bytes	Ack	Address	Ack	Data	NoAck	No
Protected with SWP	0	SWP	NoAck	Not significant	NoAck	Not significant	NoAck	No
		CWP	Ack	Not significant	Ack	Not significant	Ack	Yes
		PSWP	Ack	Not significant	Ack	Not significant	Ack	Yes
		Page or Byte Write in lower 128 bytes	Ack	Address	Ack	Data	NoAck	No
	1	SWP	NoAck	Not significant	NoAck	Not significant	NoAck	No
		CWP	Ack	Not significant	Ack	Not significant	NoAck	No
		PSWP	Ack	Not significant	Ack	Not significant	NoAck	No
		Page or Byte Write	Ack	Address	Ack	Data	NoAck	No
Not Protected	0	PSWP, SWP or CWP	Ack	Not significant	Ack	Not significant	Ack	Yes
		Page or Byte Write	Ack	Address	Ack	Data	Ack	Yes
	1	PSWP, SWP or CWP	Ack	Not significant	Ack	Not significant	NoAck	No
		Page or Byte Write	Ack	Address	Ack	Data	NoAck	No

**Table 6. Acknowledge when reading the write protection
((instructions with R/W bit = 1)**

Status	Instruction	Ack	Address	Ack	Data byte	Ack
Permanently protected	PSWP, SWP or CWP	NoAck	Not significant	NoAck	Not significant	NoAck
Protected with SWP	SWP	NoAck	Not significant	NoAck	Not significant	NoAck
	CWP	Ack	Not significant	NoAck	Not significant	NoAck
	PSWP	Ack	Not significant	NoAck	Not significant	NoAck
Not protected	PSWP, SWP or CWP	Ack	Not significant	NoAck	Not significant	NoAck

Figure 11. Serial presence detect block diagram

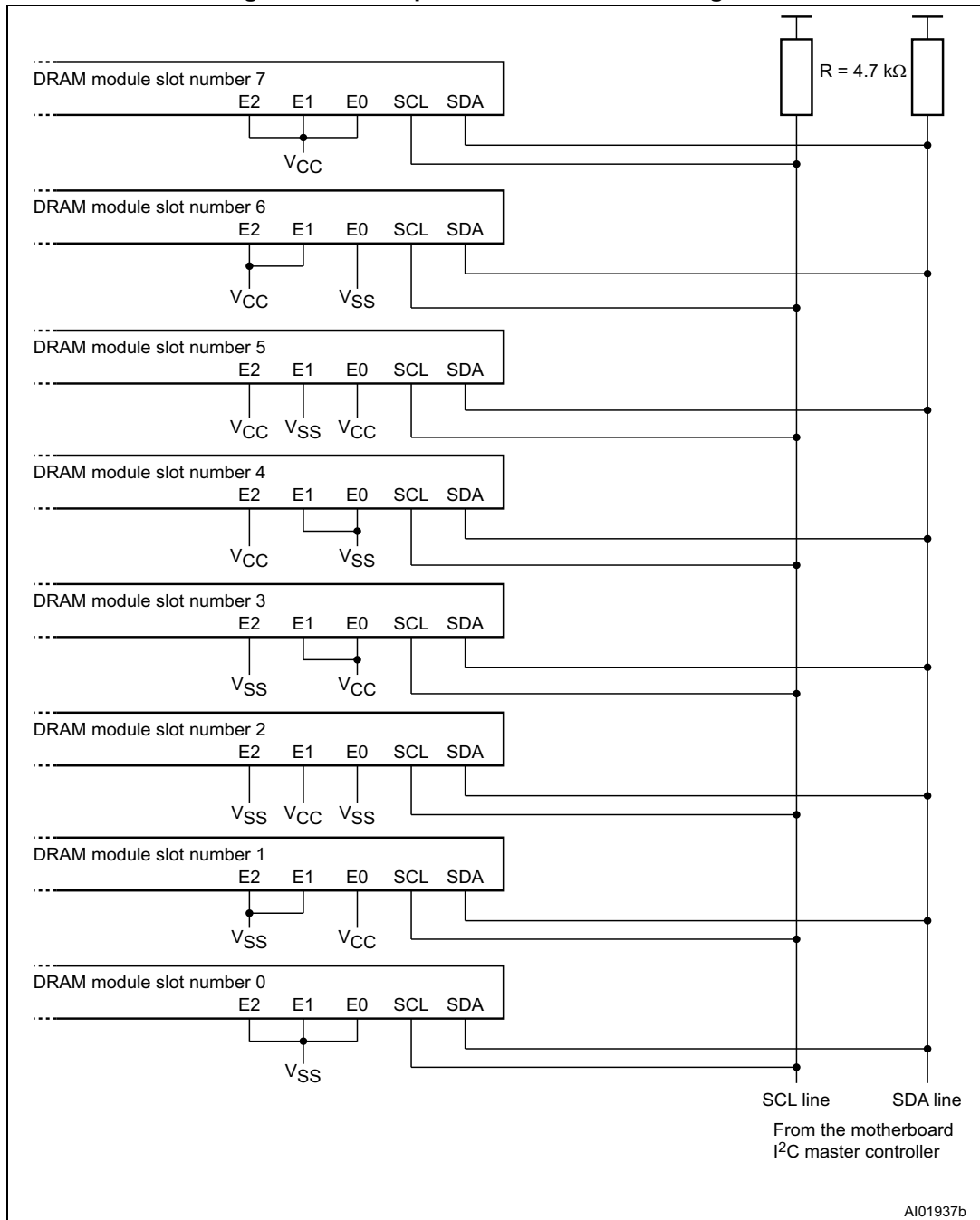

1. E0, E1 and E2 are wired at each DRAM module slot in a binary sequence for a maximum of 8 devices.
2. Common clock and common data are shared across all the devices.

6 Maximum rating

Stressing the device above the rating listed in the absolute maximum ratings table may cause permanent damage to the device. These are stress ratings only and operation of the device at these or any other conditions above those indicated in the operating sections of this specification is not implied. Exposure to absolute maximum rating conditions for extended periods may affect device reliability.

Table 7. Absolute maximum ratings

Symbol	Parameter		Min.	Max.	Unit
	Ambient temperature with power applied		-	130	°C
T _{STG}	Storage temperature		-65	150	°C
V _{IO}	Input or output range	E0 Others	-0.50 -0.50	10.0 6.5	V
I _{OL}	DC output current (SDA = 0)		-	5	mA
V _{CC}	Supply voltage		-0.5	6.5	V
V _{ESD}	Electrostatic discharge voltage (human body model) ⁽¹⁾		-	3000 ⁽²⁾	V

1. Positive and negative pulses applied on different combinations of pin connections, according to AECQ100-002 (compliant with JEDEC Std JESD22-A114, C1 = 100 pF, R1 = 1500 Ω).

2. 4000 V for devices identified by process letters S or G.

7 DC and AC parameters

This section summarizes the operating and measurement conditions, and the DC and AC characteristics of the device. The parameters in the DC and AC characteristic tables that follow are derived from tests performed under the measurement conditions summarized in the relevant tables. Designers should check that the operating conditions in their circuit match the measurement conditions when relying on the quoted parameters.

Table 8. Operating conditions (for temperature range 1 devices)

Symbol	Parameter	Min.	Max.	Unit
V_{CC}	Supply voltage	1.7	3.6	V
T_A	Ambient operating temperature	0	70	°C

Table 9. Operating conditions (for temperature range 6 devices)

Symbol	Parameter	Min.	Max.	Unit
V_{CC}	Supply voltage	1.7	5.5	V
T_A	Ambient operating temperature	-40	+85	°C

Table 10. AC measurement conditions

Symbol	Parameter	Min.	Max.	Unit
C_L	Load capacitance	100		pF
	SCL input rise and fall time, SDA input fall time	-	50	ns
	Input levels	0.2V _{CC} to 0.8V _{CC}		V
	Input and output timing reference levels	0.3V _{CC} to 0.7V _{CC}		V

Figure 12. AC measurement I/O waveform

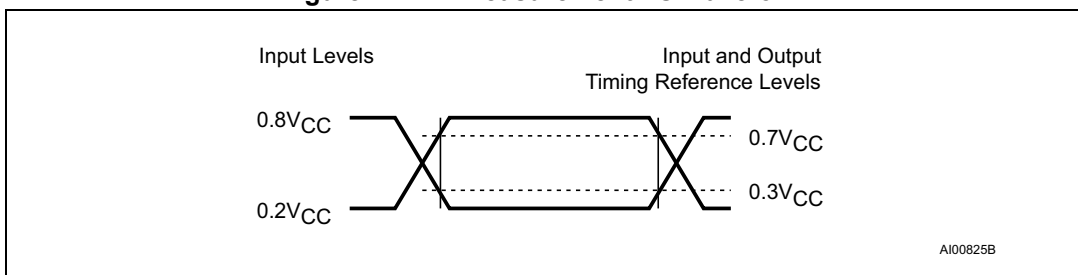

Table 11. Input parameters

Symbol	Parameter ⁽¹⁾	Test condition	Min.	Max.	Unit
C_{IN}	Input capacitance (SDA)		-	8	pF
C_{IN}	Input capacitance (other pins)		-	6	pF
Z_{EiL}	Ei (E0, E1, E2) input impedance	$V_{IN} < 0.3V_{CC}$	30	-	k Ω
Z_{EiH}	Ei (E0, E1, E2) input impedance	$V_{IN} > 0.7V_{CC}$	800	-	k Ω
$Z_{\overline{WC}L}$	\overline{WC} input impedance	$V_{IN} < 0.3V_{CC}$	5	-	k Ω
$Z_{\overline{WC}H}$	\overline{WC} input impedance	$V_{IN} > 0.7V_{CC}$	500	-	k Ω
t_{NS}	Pulse width ignored (input filter on SCL and SDA)		-	100	ns

1. Characterized, not tested in production.

Table 12. DC characteristics (for temperature range 1 devices)

Symbol	Parameter	Test condition (in addition to those in Table 8)	Min	Max	Unit
I_{LI}	Input leakage current (SCL, SDA)	$V_{IN} = V_{SS}$ or V_{CC}	-	± 2	μA
I_{LO}	Output leakage current	SDA in Hi-Z, external voltage applied on SDA: V_{SS} or V_{CC}	-	± 2	μA
I_{CC}	Supply current (read)	$V_{CC} = 1.7 V, f_c = 100 kHz$	-	1	mA
		$V_{CC} = 3.6 V, f_c = 100 kHz$	-	2	mA
I_{CC1}	Standby supply current	Device not selected ⁽¹⁾ , $V_{IN} = V_{SS}$ or $V_{CC}, V_{CC} = 3.6 V$	-	2	μA
		Device not selected ⁽¹⁾ , $V_{IN} = V_{SS}$ or $V_{CC}, V_{CC} = 1.7 V$	-	1	μA
V_{IL}	Input low voltage (SCL, SDA, \overline{WC})	$2.5 \leq V_{CC}$	-0.45	$0.3 V_{CC}$	V
		$1.7 V \leq V_{CC} < 2.5 V$	-0.45	$0.25 V_{CC}$	V
V_{IH}	Input high voltage (SCL, SDA, \overline{WC})		$0.7 V_{CC}$	$V_{CC}+1$	V
V_{HV}	E0 high voltage	$V_{HV} - V_{CC} \geq 4.8 V$	7	10	V
V_{OL}	Output low voltage	$I_{OL} = 2.1 mA, 2.2 V \leq V_{CC} \leq 3.6 V$	-	0.4	V
		$I_{OL} = 0.7 mA, V_{CC} = 1.7 V$	-	0.2	V

1. The device is not selected after a power-up, after a read command (after the Stop condition), or after the completion of the internal write cycle t_W (t_W is triggered by the correct decoding of a write command).

Table 13. DC characteristics (for temperature range 6 devices)

Symbol	Parameter	Test condition (in addition to those in Table 9)	Min	Max	Unit
I_{LI}	Input leakage current (SCL, SDA)	$V_{IN} = V_{SS}$ or V_{CC}	-	± 2	μA
I_{LO}	Output leakage current	SDA in Hi-Z, external voltage applied on SDA: V_{SS} or V_{CC}	-	± 2	μA
I_{CC}	Supply current (read)	$V_{CC} < 2.5 V, f_c = 400 kHz$	-	1	mA
		$V_{CC} \geq 2.5 V, f_c = 400 kHz$	-	3	mA
I_{CC1}	Standby supply current	Device not selected ⁽¹⁾ , $V_{IN} = V_{SS}$ or $V_{CC}, V_{CC} = 5.5 V$	-	3 ⁽²⁾	μA
		Device not selected ⁽¹⁾ , $V_{IN} = V_{SS}$ or $V_{CC}, V_{CC} = 2.5 V$	-	2 ⁽³⁾	μA
		Device not selected ⁽¹⁾ , $V_{IN} = V_{SS}$ or $V_{CC}, V_{CC} = 1.8 V$	-	1	μA
V_{IL}	Input low voltage (SCL, SDA, WC)	$2.5 \leq V_{CC}$	-0.45	$0.3 V_{CC}$	V
		$1.8 V \leq V_{CC} < 2.5 V$	-0.45	$0.25 V_{CC}$	V
V_{IH}	Input high voltage (SCL, SDA, WC)		$0.7 V_{CC}$	$V_{CC}+1$	V
V_{HV}	E0 high voltage	$V_{CC} < 2.2 V$	7	10	V
		$V_{CC} \geq 2.2 V$	$V_{CC}+4.8$	10	V
V_{OL}	Output low voltage	$I_{OL} = 3.0 mA, V_{CC} = 5.5 V$	-	0.4	V
		$I_{OL} = 2.1 mA, V_{CC} = 2.5 V$	-	0.4	V
		$I_{OL} = 0.7 mA, V_{CC} = 1.7 V$	-	0.2	V

1. The device is not selected after a power-up, after a read command (after the Stop condition), or after the completion of the internal write cycle t_W (t_W is triggered by the correct decoding of a write command).
2. The value was 2 μA when $V_{CC} \geq 2.5 V$ for devices identified with process letter G or S.
3. The value was 1 μA when $V_{CC} < 2.5 V$ for devices identified with process letter G or S.

Table 14. AC characteristics

Test conditions specified in Table 10 , Table 8 and Table 9					
Symbol	Alt.	Parameter	Min.	Max.	Unit
f_C	f_{SCL}	Clock frequency	-	400	kHz
t_{CHCL}	t_{HIGH}	Clock pulse width high	600	-	ns
t_{CLCH}	t_{LOW}	Clock pulse width low	1300	-	ns
$t_{DL1DL2}^{(1)}$	t_F	SDA (out) fall time	20	100	ns
$t_{XH1XH2}^{(2)}$	t_R	Input signal rise time	20	300	ns
$t_{XL1XL2}^{(2)}$	t_F	Input signal fall time	20	300	ns
t_{DXCX}	$t_{SU:DAT}$	Data in set up time	100	-	ns
t_{CLDX}	$t_{HD:DAT}$	Data in hold time	0	-	ns
t_{CLQX}	t_{DH}	Data out hold time	200	-	ns
$t_{CLQV}^{(3)(4)}$	t_{AA}	Clock low to next data valid (access time)	200	900	ns
$t_{CHDL}^{(5)}$	$t_{SU:STA}$	Start condition setup time	600	-	ns
t_{DLCL}	$t_{HD:STA}$	Start condition hold time	600	-	ns
t_{CHDH}	$t_{SU:STO}$	Stop condition setup time	600	-	ns
t_{DHDL}	t_{BUF}	Time between Stop condition and next Start condition	1300	-	ns
t_W	t_{WR}	Write time	-	5	ms

1. Sampled only, not 100% tested.
2. Values recommended by I²C-bus/Fast-Mode specification.
3. To avoid spurious Start and Stop conditions, a minimum delay is placed between SCL=1 and the falling or rising edge of SDA.
4. t_{CLQV} is the time (from the falling edge of SCL) required by the SDA bus line to reach either $0.3V_{CC}$ or $0.7V_{CC}$, assuming that the $R_{bus} \times C_{bus}$ time constant is within the values specified in [Figure 4](#).
5. For a re-Start condition, or following a Write cycle.

Figure 13. AC waveforms

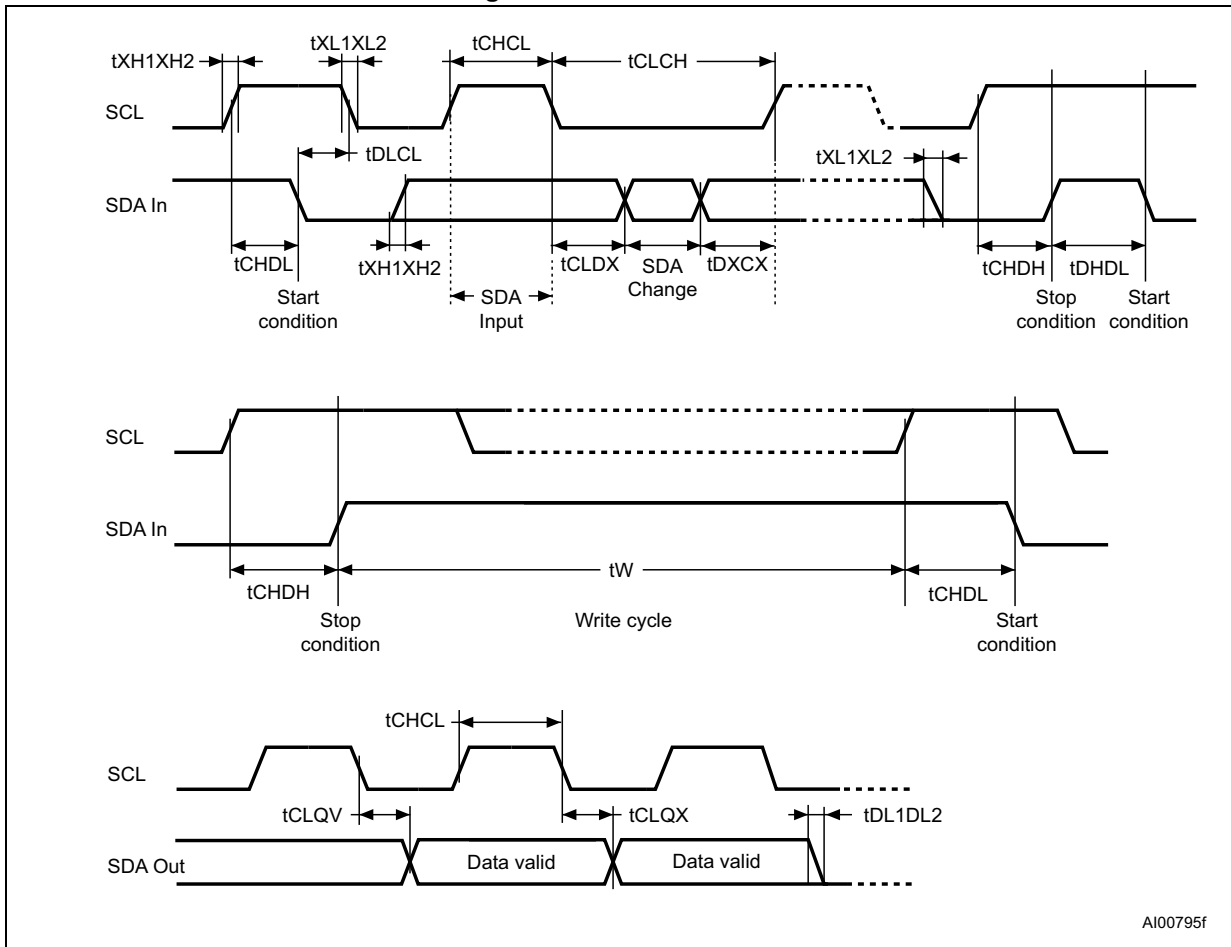

8 Package mechanical data

In order to meet environmental requirements, ST offers these devices in different grades of ECOPACK[®] packages, depending on their level of environmental compliance. ECOPACK[®] specifications, grade definitions and product status are available at: www.st.com. ECOPACK[®] is an ST trademark.

Figure 15. TSSOP8 – 8-lead thin shrink small outline, package outline

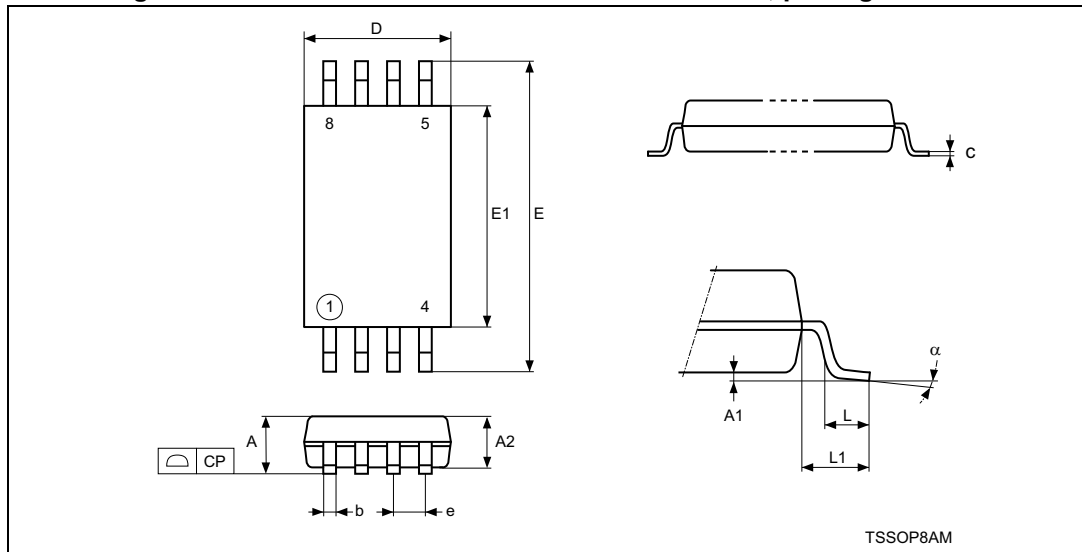

1. Drawing is not to scale.
2. The circle around the number 1 in the top view of the package indicates the position of pin 1. The numbers 4, 5 and 8 indicate the positions of pins 4, 5 and 8, respectively.

Table 16. TSSOP8 – 8-lead thin shrink small outline, package mechanical data

Symbol	millimeters			inches ⁽¹⁾		
	Typ.	Min.	Max.	Typ.	Min.	Max.
A	-	-	1.200	-	-	0.0472
A1	-	0.050	0.150	-	0.0020	0.0059
A2	1.000	0.800	1.050	0.0394	0.0315	0.0413
b	-	0.190	0.300	-	0.0075	0.0118
c	-	0.090	0.200	-	0.0035	0.0079
CP	-	-	0.100	-	-	0.0039
D	3.000	2.900	3.100	0.1181	0.1142	0.1220
e	0.650	-	-	0.0256	-	-
E	6.400	6.200	6.600	0.2520	0.2441	0.2598
E1	4.400	4.300	4.500	0.1732	0.1693	0.1772
L	0.600	0.450	0.750	0.0236	0.0177	0.0295
L1	1.000	-	-	0.0394	-	-
α	-	0°	8°	-	0°	8°
N	8			8		

1. Values in inches are converted from mm and rounded to 4 decimal digits.

9 Part numbering

Table 17. Ordering information scheme

Example:	M34E02	-	F	DW	1	T	P
Device type							
M34 = ASSP I ² C serial access EEPROM							
Device function							
E02 = 2 Kbit (256 × 8) SPD (serial presence detect) for DDD RAM modules							
Operating voltage							
F = V _{CC(min)} = 1.7 V							
Temperature range1: V _{CC} = 1.7 to 3.6 V over 0°C to 70 °C ⁽¹⁾							
Temperature range6: V _{CC} = 1.7 to 5.5 V over -40 °C to 85 °C ⁽²⁾							
Package							
MC= UFDFPN8 (MLP8)							
DW = TSSOP8 (4.4 × 3 mm body size)							
Temperature range							
1 = 0 to 70 °C							
6 = -40 to 85 °C							
Option							
blank = Standard packing							
T = Tape & reel packing							
Plating technology							
P or G = ECOPACK (RoHS compliant)							

1. The 1.7 to 3.6 V operating voltage range is available only on temperature range 1 devices.
2. The 1.7 to 5.5 V operating voltage range is available only on temperature range 6 devices.

For a list of available options (speed, package, etc.) or for further information on any aspect of this device, please contact your nearest ST sales office.

10 Revision history

Table 18. Document revision history

Date	Revision	Changes
13-Nov-2003	1.0	First release
01-Dec-2003	1.1	TSSOP8 4.4x3 package replaces TSSOP8 3x3 (MSOP8) package. Correction to sentence in "Setting the Write Protection". Correction to specification of t_{NS} values.
29-Mar-2004	1.2	Always NoACK after Address and Data bytes in Table 6 . Improvement in V_{IO} and V_{CC} (min) in Absolute Maximum Ratings table. I_{OL} changed for test condition of V_{OL} . MLP package mechanical data respecified. Soldering temperature information clarified for RoHS compliant devices.
14-Apr-2004	2.0	First public release
24-Nov-2004	3.0	Direct connection of E0, E1, E2 to V_{SS} and V_{CC} (see Chip Enable (E0, E1, E2) and Use within a DDR1/DDR2/DDR3 DRAM module paragraphs). Z_{EiL} and Z_{EiH} parameters added to Table 11: Input parameters . E0, E1, E2 removed from the Parameter descriptions of V_{iL} and V_{iH} in Table 13: DC characteristics (for temperature range 6 devices) . Document status promoted from Product Preview to full Datasheet.
11-Mar-2005	4.0	Datasheet title changed. Features revised. Plating Technology options updated in Table 17: Ordering information scheme . Resistance and capacitance renamed in Figure 4: Maximum R_p value versus bus parasitic capacitance (C) for an I²C bus .
28 -Apr-2005	5.0	Text in Power On Reset changed. Noise filter value in Table 11: Input parameters modified. I_{CC} value 2mA, when $V_{CC}=3/6V$, added to Table 13: DC characteristics (for temperature range 6 devices) .
10-Apr-2006	6	In Table 14: AC characteristics : Frequency f_C changed from 100kHz to 400kHz, related AC timings (t_{CHCL} , t_{CLCH} , t_{DXCX} , t_{CLQV} max, t_{CHDX} , t_{DLCL} , t_{CHDH} , t_{DHDL}) also modified. Power On Reset paragraph removed replaced by Internal device reset . Figure 3: Device select code inserted. I_{CC1} modified in Table 13: DC characteristics (for temperature range 6 devices) . Note 3 added to Figure 14 and Note 2 added to Figure 15 . All packages are ECOPACK® (see text added under Description and Part numbering , T_{LEAD} removed from Table 7: Absolute maximum ratings).

Table 18. Document revision history (continued)

Date	Revision	Changes
18-Mar-2009	7	Datasheet title and <i>Features on page 1</i> modified: the device can be used with DDR1 and DDR2 DRAM configurations. Temperature range 6 added, operating voltage range V_{CC} extended in device temperature range 6. I_{OL} added to and T_A modified in <i>Table 7: Absolute maximum ratings</i> . I_{LO} , I_{CC} and V_{IL} modified in <i>Table 13: DC characteristics (for temperature range 6 devices)</i> . <i>Table 14: AC characteristics</i> added. <i>Table 13: DC characteristics (for temperature range 6 devices)</i> modified. <i>Figure 13: AC waveforms</i> modified. <i>Figure 4: Maximum R_P value versus bus parasitic capacitance (C) for an I²C bus</i> updated. Note removed below <i>Figure 11: Serial presence detect block diagram</i> . UFDFPN8 package specifications updated (see <i>Table 15: UFDFPN8 (MLP8) 8-lead ultra thin fine pitch dual flat package no lead 2 x 3 mm, data</i>). Blank option removed under plating technology in <i>Table 17: Ordering information scheme</i> . Small text changes.
25-Sep-2009	8	<i>Section 2.5.2: Power-up conditions</i> and <i>Section 2.5.3: Device reset</i> updated. <i>Figure 4: Maximum R_P value versus bus parasitic capacitance (C) for an I²C bus</i> modified. t_{NS} modified in <i>Table 11: Input parameters</i> . I_{CC} and V_{IL} test conditions extended in <i>Table 12: DC characteristics (for temperature range 1 devices)</i> .
01-Apr-2010	9	Test condition updated in <i>Table 12: DC characteristics (for temperature range 1 devices)</i> and <i>Table 13: DC characteristics (for temperature range 6 devices)</i> Updated <i>Figure 14: UFDFPN8 (MLP8) – 8-lead ultra thin fine pitch dual flat package no lead 2 x 3 mm, outline</i> and <i>Table 15: UFDFPN8 (MLP8) 8-lead ultra thin fine pitch dual flat package no lead 2 x 3 mm, data</i>
23-Jul-2010	10	Added M34E02-F part number. Added ambient temperature with power applied in <i>Table 7: Absolute maximum ratings</i> . Updated I_{CC1} conditions in <i>Table 12: DC characteristics (for temperature range 1 devices)</i> . Added <i>Note 4</i> for t_{CLQV} in <i>Table 14: AC characteristics</i> . Updated <i>Figure 13: AC waveforms</i> . t_{CHDX} replaced by t_{CHDL} in <i>Figure 13: AC waveforms</i> . Modified MC package outline in <i>Figure 14: UFDFPN8 (MLP8) – 8-lead ultra thin fine pitch dual flat package no lead 2 x 3 mm, outline</i> .
27-May-2011	11	Updated MLP8 package data.
22-Jan-2013	12	Removed M34E02 part number. Updated information relating to package UFDFPN8 (MLP8). Rephrased <i>Description</i> . Updated <i>Table 7: Absolute maximum ratings</i> and <i>Table 13: DC characteristics (for temperature range 6 devices)</i> .

Table 18. Document revision history (continued)

Date	Revision	Changes
18-Feb-2013	13	Specified I_{CC1} (Standby supply current) with three different values of V_{CC} (5.5 V, 2.5 V and 1.8 V) in Table 13: DC characteristics (for temperature range 6 devices) . Replaced “DDR1/DDR2” with “DDR1/DDR2/DDR3” throughout the document.
14-May-2013	14	Document reformatted. Updated: – Figure 4: Maximum R_P value versus bus parasitic capacitance (C) for an I²C bus – Order code and operating voltage information in Table 17: Ordering information scheme

Please Read Carefully:

Information in this document is provided solely in connection with ST products. STMicroelectronics NV and its subsidiaries ("ST") reserve the right to make changes, corrections, modifications or improvements, to this document, and the products and services described herein at any time, without notice.

All ST products are sold pursuant to ST's terms and conditions of sale.

Purchasers are solely responsible for the choice, selection and use of the ST products and services described herein, and ST assumes no liability whatsoever relating to the choice, selection or use of the ST products and services described herein.

No license, express or implied, by estoppel or otherwise, to any intellectual property rights is granted under this document. If any part of this document refers to any third party products or services it shall not be deemed a license grant by ST for the use of such third party products or services, or any intellectual property contained therein or considered as a warranty covering the use in any manner whatsoever of such third party products or services or any intellectual property contained therein.

UNLESS OTHERWISE SET FORTH IN ST'S TERMS AND CONDITIONS OF SALE ST DISCLAIMS ANY EXPRESS OR IMPLIED WARRANTY WITH RESPECT TO THE USE AND/OR SALE OF ST PRODUCTS INCLUDING WITHOUT LIMITATION IMPLIED WARRANTIES OF MERCHANTABILITY, FITNESS FOR A PARTICULAR PURPOSE (AND THEIR EQUIVALENTS UNDER THE LAWS OF ANY JURISDICTION), OR INFRINGEMENT OF ANY PATENT, COPYRIGHT OR OTHER INTELLECTUAL PROPERTY RIGHT.

ST PRODUCTS ARE NOT AUTHORIZED FOR USE IN WEAPONS. NOR ARE ST PRODUCTS DESIGNED OR AUTHORIZED FOR USE IN: (A) SAFETY CRITICAL APPLICATIONS SUCH AS LIFE SUPPORTING, ACTIVE IMPLANTED DEVICES OR SYSTEMS WITH PRODUCT FUNCTIONAL SAFETY REQUIREMENTS; (B) AERONAUTIC APPLICATIONS; (C) AUTOMOTIVE APPLICATIONS OR ENVIRONMENTS, AND/OR (D) AEROSPACE APPLICATIONS OR ENVIRONMENTS. WHERE ST PRODUCTS ARE NOT DESIGNED FOR SUCH USE, THE PURCHASER SHALL USE PRODUCTS AT PURCHASER'S SOLE RISK, EVEN IF ST HAS BEEN INFORMED IN WRITING OF SUCH USAGE, UNLESS A PRODUCT IS EXPRESSLY DESIGNATED BY ST AS BEING INTENDED FOR "AUTOMOTIVE, AUTOMOTIVE SAFETY OR MEDICAL" INDUSTRY DOMAINS ACCORDING TO ST PRODUCT DESIGN SPECIFICATIONS. PRODUCTS FORMALLY ESCC, QML OR JAN QUALIFIED ARE DEEMED SUITABLE FOR USE IN AEROSPACE BY THE CORRESPONDING GOVERNMENTAL AGENCY.

Resale of ST products with provisions different from the statements and/or technical features set forth in this document shall immediately void any warranty granted by ST for the ST product or service described herein and shall not create or extend in any manner whatsoever, any liability of ST.

ST and the ST logo are trademarks or registered trademarks of ST in various countries.

Information in this document supersedes and replaces all information previously supplied.

The ST logo is a registered trademark of STMicroelectronics. All other names are the property of their respective owners.

© 2013 STMicroelectronics - All rights reserved

STMicroelectronics group of companies

Australia - Belgium - Brazil - Canada - China - Czech Republic - Finland - France - Germany - Hong Kong - India - Israel - Italy - Japan - Malaysia - Malta - Morocco - Philippines - Singapore - Spain - Sweden - Switzerland - United Kingdom - United States of America





www.st.com

Looking for pricing, stock, or lifecycle information?

Click below to explore more details on WIN SOURCE:

-  [View M34E02-FMB1TG on WIN SOURCE](#)
-  [STMicroelectronics](#) Information

Optimize Your Supply Chain with WIN SOURCE Solutions

-  Global Sourcing Solution
-  Obsolete Management
-  Cost Control Management
-  Shortage Management
-  Alternative Solution
-  Excess Inventory Management