



**THE DATASHEET OF
M29W400DB70N1**



4 Mbit (512 Kb x 8 or 256 Kb x 16, boot block)
3 V supply Flash memory

Features

- Supply voltage
 - $V_{CC} = 2.7\text{ V to }3.6\text{ V}$ for Program, Erase and Read
- Access time: 45, 55, 70 ns
- Programming time
 - 10 μs per byte/word typical
- 11 memory blocks
 - 1 boot block (top or bottom location)
 - 2 parameter and 8 main blocks
- Program/Erase controller
 - Embedded byte/word program algorithms
- Erase Suspend and Resume modes
 - Read and Program another block during Erase Suspend
- Unlock bypass program command
 - Faster production/batch programming
- Temporary block unprotection mode
- Low power consumption
 - Standby and Automatic Standby
- 100,000 Program/Erase cycles per block
- Electronic signature
 - Manufacturer code: 0020h
 - Top device code M29W400DT: 00EEh
 - Bottom device code M29W400DB: 00EFh
 - RoHS packages
- Automotive Device Grade 3
 - Temperature: $-40\text{ to }125\text{ }^{\circ}\text{C}$
 - Automotive grade certified

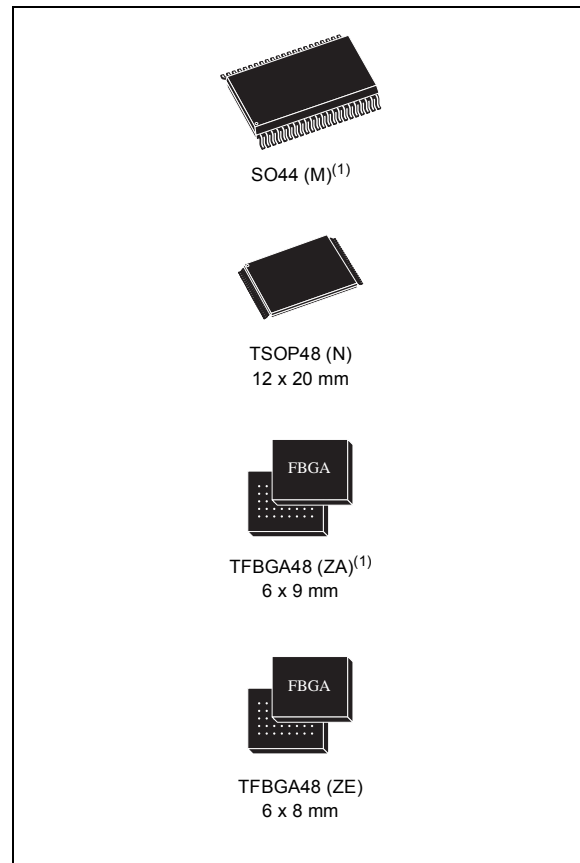

1. These packages are no more in mass production.

Contents

1	Description	6
2	Signal descriptions	13
2.1	Address inputs (A0-A17)	13
2.2	Data inputs/outputs (DQ0-DQ7)	13
2.3	Data inputs/outputs (DQ8-DQ14)	13
2.4	Data input/output or Address input (DQ15A-1)	13
2.5	Chip Enable (\bar{E})	13
2.6	Output Enable (\bar{G})	13
2.7	Write Enable (\bar{W})	14
2.8	Reset/Block Temporary Unprotect (\bar{RP})	14
2.9	Ready/Busy output (\bar{RB})	14
2.10	Byte/Word Organization Select (\bar{BYTE})	14
2.11	V_{CC} supply voltage	15
2.12	V_{SS} ground	15
3	Bus operations	16
3.1	Bus Read	16
3.2	Bus Write	16
3.3	Output Disable	16
3.4	Standby	16
3.5	Automatic Standby	16
3.6	Special bus operations	17
3.7	Electronic signature	17
3.8	Block protection and blocks unprotection	17
4	Command interface	19
4.1	Read/Reset command	19
4.2	Auto Select command	19
4.3	Program command	19
4.4	Unlock Bypass command	20
4.5	Unlock Bypass Program command	20

4.6	Unlock Bypass Reset command	20
4.7	Chip Erase command	20
4.8	Block Erase command	21
4.9	Erase Suspend command	21
4.10	Erase Resume command	22
4.11	Block Protect and Chip Unprotect commands	22
5	Status Register	24
5.1	Data Polling bit (DQ7)	24
5.2	Toggle bit (DQ6)	24
5.3	Error bit (DQ5)	25
5.4	Erase Timer bit (DQ3)	25
5.5	Alternative Toggle bit (DQ2)	25
6	Maximum rating	28
7	DC and AC parameters	29
8	Package mechanical	35
9	Part numbering	39
Appendix A	Block address table	40
Appendix B	Block protection	41
B.1	Programmer technique	41
B.2	In-system technique	41
10	Revision history	47

List of tables

Table 1.	Signal names	7
Table 2.	Bus operations, $\overline{\text{BYTE}} = V_{\text{IL}}$	17
Table 3.	Bus operations, $\overline{\text{BYTE}} = V_{\text{IH}}$	18
Table 4.	Program, Erase times and Program, Erase endurance cycles	22
Table 5.	Commands, 16-bit mode, $\overline{\text{BYTE}} = V_{\text{IH}}$	23
Table 6.	Commands, 8-bit mode, $\overline{\text{BYTE}} = V_{\text{IL}}$	23
Table 7.	Status Register bits	25
Table 8.	Absolute maximum ratings	28
Table 9.	Operating and AC measurement conditions	29
Table 10.	Device capacitance	30
Table 11.	DC characteristics	30
Table 12.	Read AC characteristics	31
Table 13.	Write AC characteristics, Write Enable controlled	32
Table 14.	Write AC characteristics, Chip Enable controlled	33
Table 15.	Reset/Block Temporary Unprotect AC characteristics	34
Table 16.	SO44 – 44 lead plastic small outline, 525 mils body width, package mechanical data	35
Table 17.	TSOP48 – 48 lead plastic thin small outline, 12 x 20 mm, package mechanical data	36
Table 18.	TFBGA48 6 x 9 mm, 6 x 8 active ball array, 0.80 mm pitch, package mechanical data	37
Table 19.	TFBGA48 6 x 8 mm, 6 x 8 active ball array, 0.80 mm pitch, package mechanical data	38
Table 20.	Ordering information scheme	39
Table 21.	Top boot block addresses M29W400DT	40
Table 22.	Bottom boot block addresses M29W400DB	40
Table 23.	Programmer technique bus operations, $\overline{\text{BYTE}} = V_{\text{IH}}$ or V_{IL}	42
Table 24.	Document revision history	47

List of figures

Figure 1.	Logic diagram	7
Figure 2.	SO connections	8
Figure 3.	TSOP connections	9
Figure 4.	TFBGA connections (top view through package)	10
Figure 5.	Block addresses (x 8)	11
Figure 6.	Block addresses (x 16)	12
Figure 7.	Data polling flowchart	26
Figure 8.	Data toggle flowchart	27
Figure 9.	AC measurement I/O waveform	29
Figure 10.	AC measurement load circuit	29
Figure 11.	Read mode AC waveforms	30
Figure 12.	Write AC waveforms, Write Enable controlled	32
Figure 13.	Write AC waveforms, Chip Enable controlled	33
Figure 14.	Reset/Block Temporary Unprotect AC waveforms	34
Figure 15.	SO44 - 44 lead plastic small outline, 525 mils body width, package outline	35
Figure 16.	TSOP48 – 48 lead plastic thin small outline, 12 x 20 mm, package outline	36
Figure 17.	TFBGA48 6 x 9 mm, 6 x 8 active ball array, 0.80 mm pitch, bottom view package outline	37
Figure 18.	TFBGA48 6 x 8 mm, 6 x 8 active ball array, 0.80 mm pitch, bottom view package outline	38
Figure 19.	Programmer equipment block protect flowchart	43
Figure 20.	Programmer equipment chip unprotect flowchart	44
Figure 21.	In-system equipment block protect flowchart	45
Figure 22.	In-system equipment chip unprotect flowchart	46

1 Description

The M29W400D is a 4 Mbit (512 K x 8 or 256 K x 16) non-volatile memory that can be read, erased and reprogrammed. These operations can be performed using a single low voltage (2.7 to 3.6 V) supply. On power-up the memory defaults to its Read mode where it can be read in the same way as a ROM or EPROM.

The memory is divided into blocks that can be erased independently so it is possible to preserve valid data while old data is erased. Each block can be protected independently to prevent accidental Program or Erase commands from modifying the memory. Program and Erase commands are written to the command interface of the memory. An on-chip Program/Erase controller simplifies the process of programming or erasing the memory by taking care of all of the special operations that are required to update the memory contents.

The end of a program or erase operation can be detected and any error conditions identified. The command set required to control the memory is consistent with JEDEC standards.

The blocks in the memory are asymmetrically arranged, see [Figure 5](#) and [Figure 6](#), Block addresses. The first or last 64 Kbytes have been divided into four additional blocks. The 16 Kbyte boot block can be used for small initialization code to start the microprocessor, the two 8 Kbyte parameter blocks can be used for parameter storage and the remaining 32 Kbyte is a small main block where the application may be stored.

Chip Enable, Output Enable and Write Enable signals control the bus operation of the memory. They allow simple connection to most microprocessors, often without additional logic.

The memory is offered in SO44, TSOP48 (12 x 20 mm), TFBGA48 0.8 mm pitch (6 x 9 mm and 6 x 8 mm) packages. The memory is supplied with all the bits erased (set to '1').

In order to meet environmental requirements, Numonyx offers the M29W400D in RoHS packages, which are Lead-free. The category of second level interconnect is marked on the package and on the inner box label, in compliance with JEDEC Standard JESD97. The maximum ratings related to soldering conditions are also marked on the inner box label.

Figure 1. Logic diagram

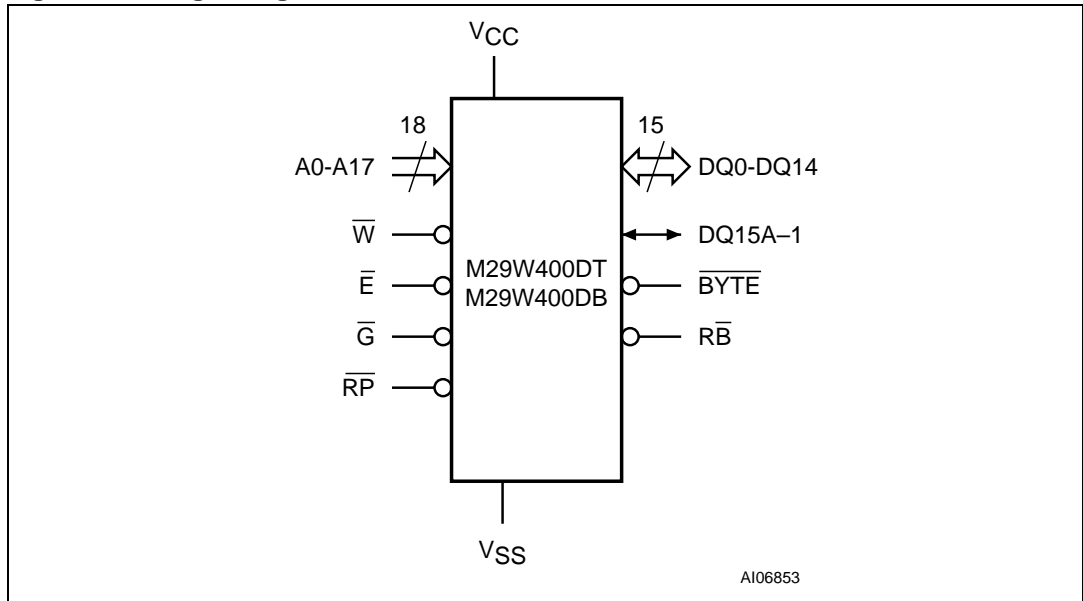
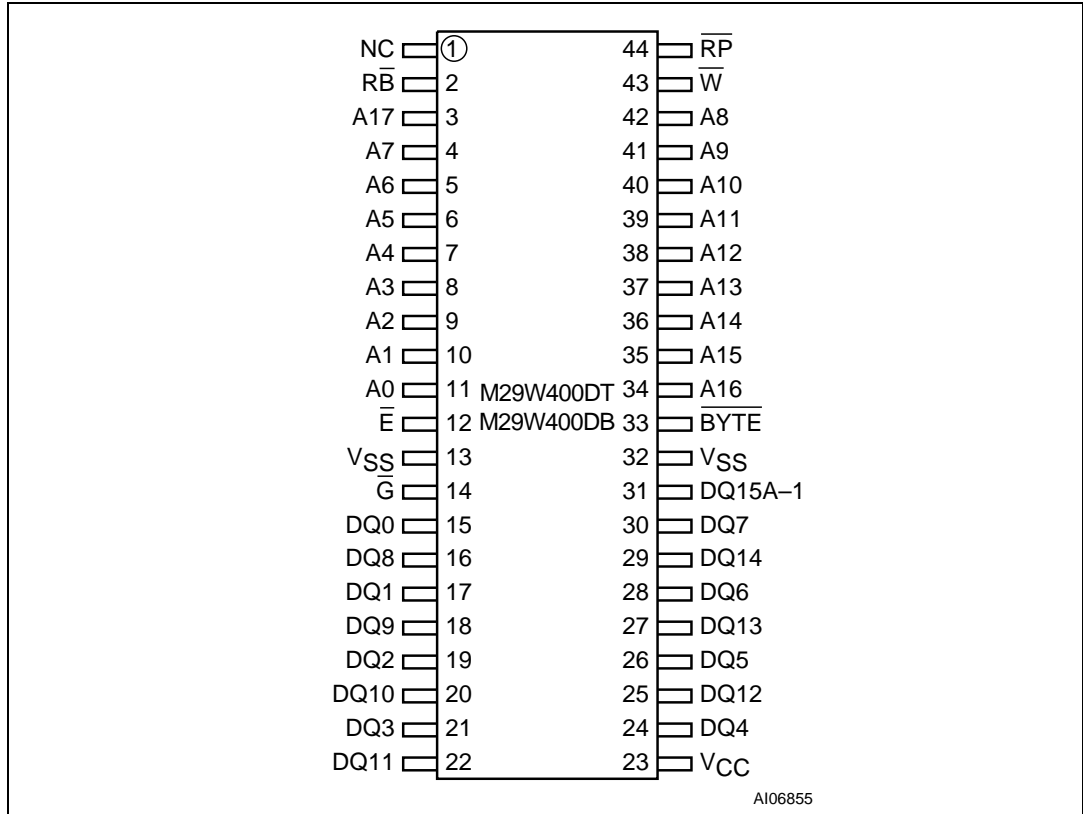

Table 1. Signal names

Signal name	Function	Direction
A0-A17	Address inputs	Inputs
DQ0-DQ7	Data inputs/outputs	I/O
DQ8-DQ14	Data inputs/outputs	I/O
DQ15A-1	Data input/output or Address input	I/O
\bar{E}	Chip Enable	Input
\bar{G}	Output Enable	Input
\bar{W}	Write Enable	Input
\bar{RP}	Reset/Block Temporary Unprotect	Input
\bar{RB}	Ready/Busy output	Output
$\overline{\text{BYTE}}$	Byte/word organization select	Input
V_{CC}	Supply voltage	
V_{SS}	Ground	
NC	Not connected internally	

Figure 2. SO connections



1. NC = Not connected.

Figure 3. TSOP connections

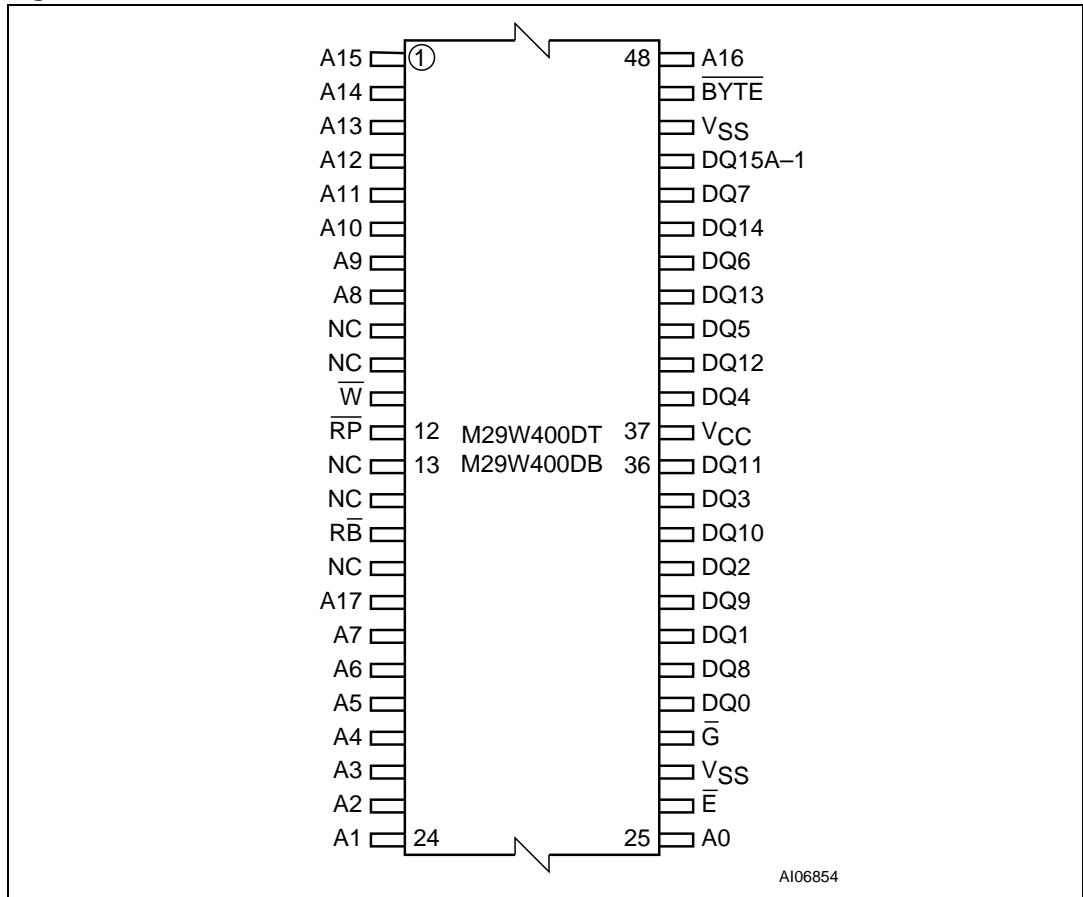
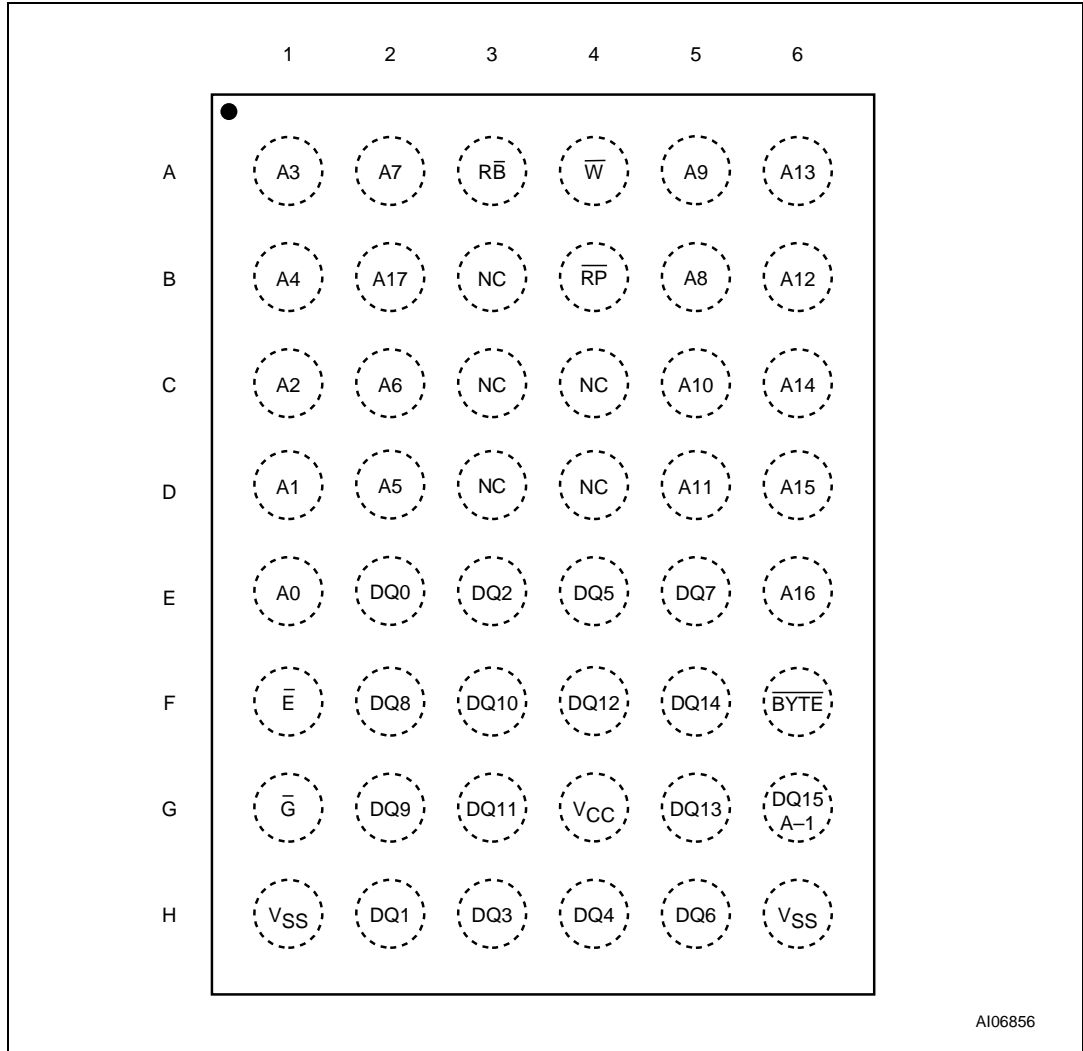
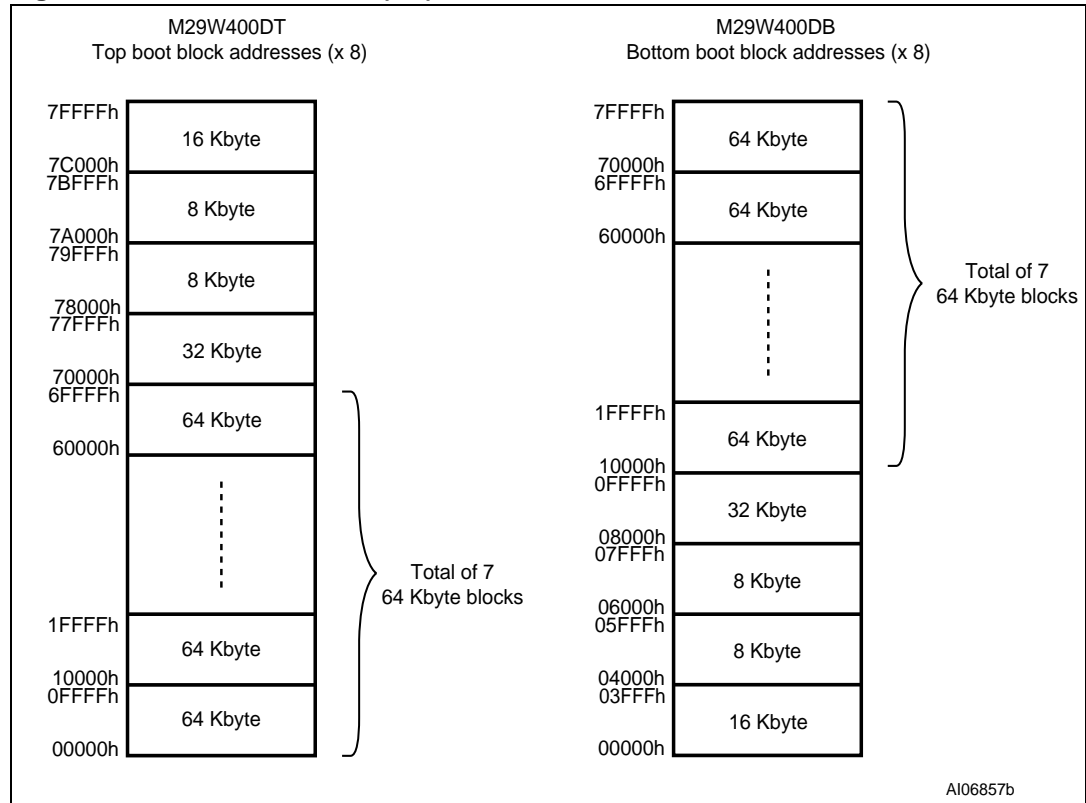

Figure 4. TFBGA connections (top view through package)



1. NC = Not connected.

Figure 5. Block addresses (x 8)



- Also see [Appendix A: Block address table, Table 21: Top boot block addresses M29W400DT](#) and [Table 22: Bottom boot block addresses M29W400DB](#) for a full listing of the block addresses.

Figure 6. Block addresses (x 16)

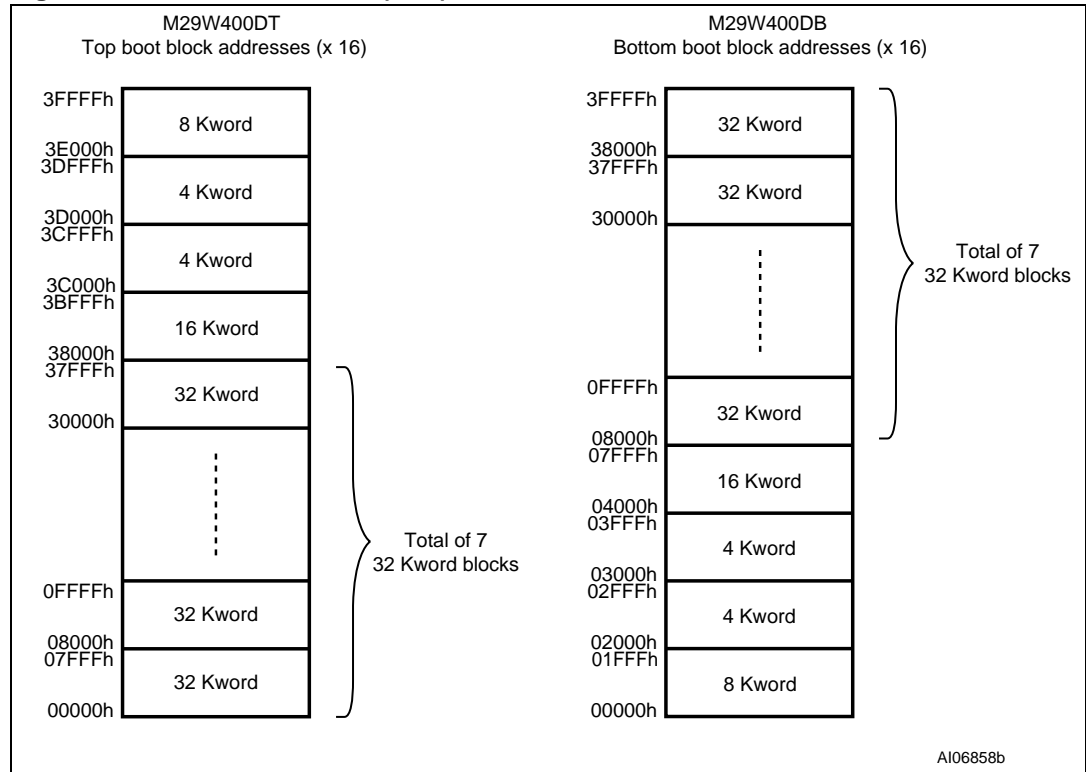

1. Also see [Appendix A: Block address table, Table 21: Top boot block addresses M29W400DT](#) and [Table 22: Bottom boot block addresses M29W400DB](#) for a full listing of the block addresses.

2 Signal descriptions

See [Figure 1: Logic diagram](#), and [Table :](#), for a brief overview of the signals connected to this device.

2.1 Address inputs (A0-A17)

The Address inputs select the cells in the memory array to access during Bus Read operations. During Bus Write operations they control the commands sent to the command interface of the Program/Erase controller.

2.2 Data inputs/outputs (DQ0-DQ7)

The Data inputs/outputs output the data stored at the selected address during a Bus Read operation. During Bus Write operations they represent the commands sent to the command interface of the Program/Erase controller.

2.3 Data inputs/outputs (DQ8-DQ14)

The Data inputs/outputs output the data stored at the selected address during a Bus Read operation when $\overline{\text{BYTE}}$ is High, V_{IH} . When $\overline{\text{BYTE}}$ is Low, V_{IL} , these pins are not used and are high impedance. During Bus Write operations the Command Register does not use these bits. When reading the Status Register these bits should be ignored.

2.4 Data input/output or Address input (DQ15A-1)

When $\overline{\text{BYTE}}$ is High, V_{IH} , this pin behaves as a Data input/output pin (as DQ8-DQ14). When $\overline{\text{BYTE}}$ is Low, V_{IL} , this pin behaves as an address pin; DQ15A-1 Low will select the LSB of the word on the other addresses, DQ15A-1 High will select the MSB. Throughout the text consider references to the Data input/output to include this pin when $\overline{\text{BYTE}}$ is High and references to the Address inputs to include this pin when $\overline{\text{BYTE}}$ is Low except when stated explicitly otherwise.

2.5 Chip Enable ($\overline{\text{E}}$)

The Chip Enable, $\overline{\text{E}}$, activates the memory, allowing Bus Read and Bus Write operations to be performed. When Chip Enable is High, V_{IH} , all other pins are ignored.

2.6 Output Enable ($\overline{\text{G}}$)

The Output Enable, $\overline{\text{G}}$, controls the Bus Read operation of the memory.

2.7 Write Enable (\overline{W})

The Write Enable, \overline{W} , controls the Bus Write operation of the memory's command interface.

2.8 Reset/Block Temporary Unprotect (\overline{RP})

The Reset/Block Temporary Unprotect pin can be used to apply a hardware reset to the memory or to temporarily unprotect all blocks that have been protected.

A hardware reset is achieved by holding Reset/Block Temporary Unprotect Low, V_{IL} , for at least t_{PLPX} . After Reset/Block Temporary Unprotect goes High, V_{IH} , the memory will be ready for Bus Read and Bus Write operations after t_{PHEL} or t_{RHEL} , whichever occurs last. See the Ready/Busy output section, [Table 15: Reset/Block Temporary Unprotect AC characteristics](#) and [Figure 14: Reset/Block Temporary Unprotect AC waveforms](#), for more details.

Holding \overline{RP} at V_{ID} will temporarily unprotect the protected blocks in the memory. Program and Erase operations on all blocks will be possible. The transition from V_{IH} to V_{ID} must be slower than t_{PHPHH} .

2.9 Ready/Busy output (\overline{RB})

The Ready/Busy pin is an open-drain output that can be used to identify when the memory array can be read. Ready/Busy is high-impedance during Read mode, Auto Select mode and Erase Suspend mode.

After a Hardware Reset, Bus Read and Bus Write operations cannot begin until Ready/Busy becomes high-impedance. See [Table 15: Reset/Block Temporary Unprotect AC characteristics](#) and [Figure 14: Reset/Block Temporary Unprotect AC waveforms](#).

During Program or Erase operations Ready/Busy is Low, V_{OL} . Ready/Busy will remain Low during Read/Reset commands or hardware resets until the memory is ready to enter Read mode.

2.10 Byte/Word Organization Select (\overline{BYTE})

The Byte/Word Organization Select pin is used to switch between the 8-bit and 16-bit Bus modes of the memory. When Byte/Word Organization Select is Low, V_{IL} , the memory is in 8-bit mode, when it is High, V_{IH} , the memory is in 16-bit mode.

2.11 V_{CC} supply voltage

The V_{CC} supply voltage supplies the power for all operations (Read, Program, Erase etc.).

The command interface is disabled when the V_{CC} supply voltage is less than the lockout voltage, V_{LKO} . This prevents Bus Write operations from accidentally damaging the data during power-up, power-down and power surges. If the Program/Erase controller is programming or erasing during this time then the operation aborts and the memory contents being altered will be invalid.

A 0.1 μF capacitor should be connected between the V_{CC} supply voltage pin and the V_{SS} ground pin to decouple the current surges from the power supply. The PCB track widths must be sufficient to carry the currents required during program and erase operations, I_{CC3} .

2.12 V_{SS} ground

The V_{SS} ground is the reference for all voltage measurements.

3 Bus operations

There are five standard bus operations that control the device. These are Bus Read, Bus Write, Output Disable, Standby and Automatic Standby. See [Table 2](#) and [Table 3](#), Bus operations, for a summary. Typically glitches of less than 5 ns on Chip Enable or Write Enable are ignored by the memory and do not affect bus operations.

3.1 Bus Read

Bus Read operations read from the memory cells, or specific registers in the command interface. A valid Bus Read operation involves setting the desired address on the Address inputs, applying a Low signal, V_{IL} , to Chip Enable and Output Enable and keeping Write Enable High, V_{IH} . The Data inputs/outputs will output the value, see [Figure 11: Read mode AC waveforms](#), and [Table 12: Read AC characteristics](#), for details of when the output becomes valid.

3.2 Bus Write

Bus Write operations write to the command interface. A valid Bus Write operation begins by setting the desired address on the Address inputs. The Address inputs are latched by the command interface on the falling edge of Chip Enable or Write Enable, whichever occurs last. The Data inputs/outputs are latched by the command interface on the rising edge of Chip Enable or Write Enable, whichever occurs first. Output Enable must remain High, V_{IH} , during the whole Bus Write operation. See [Figure 12](#) and [Figure 13](#), Write AC waveforms, and [Table 13](#) and [Table 14](#), Write AC characteristics, for details of the timing requirements.

3.3 Output Disable

The Data inputs/outputs are in the high impedance state when Output Enable is High, V_{IH} .

3.4 Standby

When Chip Enable is High, V_{IH} , the memory enters Standby mode and the Data inputs/outputs pins are placed in the high-impedance state. To reduce the Supply current to the Standby Supply current, I_{CC2} , Chip Enable should be held within $V_{CC} \pm 0.2$ V. For the Standby current level see [Table 11: DC characteristics](#).

During program or erase operations the memory will continue to use the Program/Erase Supply current, I_{CC3} , for Program or Erase operations until the operation completes.

3.5 Automatic Standby

If CMOS levels ($V_{CC} \pm 0.2$ V) are used to drive the bus and the bus is inactive for 150 ns or more the memory enters Automatic Standby where the internal Supply current is reduced to the Standby Supply current, I_{CC2} . The Data inputs/outputs will still output data if a Bus Read operation is in progress.

3.6 Special bus operations

Additional bus operations can be performed to read the electronic signature and also to apply and remove block protection. These bus operations are intended for use by programming equipment and are not usually used in applications. They require V_{ID} to be applied to some pins.

3.7 Electronic signature

The memory has two codes, the manufacturer code and the device code, that can be read to identify the memory. These codes can be read by applying the signals listed in [Table 2](#) and [Table 3](#), Bus operations.

3.8 Block protection and blocks unprotection

Each block can be separately protected against accidental Program or Erase. Protected blocks can be unprotected to allow data to be changed.

There are two methods available for protecting and unprotecting the blocks, one for use on programming equipment and the other for in-system use. Block Protect and Chip Unprotect operations are described in [Appendix B: Block protection](#).

Table 2. Bus operations, $\overline{\text{BYTE}} = V_{IL}$ ⁽¹⁾

Operation	$\overline{\text{E}}$	$\overline{\text{G}}$	$\overline{\text{W}}$	Address inputs DQ15A-1, A0-A17	Data inputs/outputs	
					DQ14-DQ8	DQ7-DQ0
Bus Read	V_{IL}	V_{IL}	V_{IH}	Cell address	Hi-Z	Data output
Bus Write	V_{IL}	V_{IH}	V_{IL}	Command address	Hi-Z	Data input
Output Disable	X	V_{IH}	V_{IH}	X	Hi-Z	Hi-Z
Standby	V_{IH}	X	X	X	Hi-Z	Hi-Z
Read manufacturer code	V_{IL}	V_{IL}	V_{IH}	A0 = V_{IL} , A1 = V_{IL} , A9 = V_{ID} , others V_{IL} or V_{IH}	Hi-Z	20h
Read device code	V_{IL}	V_{IL}	V_{IH}	A0 = V_{IH} , A1 = V_{IL} , A9 = V_{ID} , others V_{IL} or V_{IH}	Hi-Z	EEh (M29W400DT) EFh (M29W400DB)

1. X = V_{IL} or V_{IH} .

Table 3. Bus operations, $\overline{\text{BYTE}} = V_{IH}$

Operation	$\overline{\text{E}}$	$\overline{\text{G}}$	$\overline{\text{W}}$	Address inputs A0-A17	Data inputs/outputs DQ15A-1, DQ14-DQ0
Bus Read	V_{IL}	V_{IL}	V_{IH}	Cell address	Data output
Bus Write	V_{IL}	V_{IH}	V_{IL}	Command address	Data input
Output Disable	X	V_{IH}	V_{IH}	X	Hi-Z
Standby	V_{IH}	X	X	X	Hi-Z
Read manufacturer code	V_{IL}	V_{IL}	V_{IH}	A0 = V_{IL} , A1 = V_{IL} , A9 = V_{ID} , others V_{IL} or V_{IH}	0020h
Read device code	V_{IL}	V_{IL}	V_{IH}	A0 = V_{IH} , A1 = V_{IL} , A9 = V_{ID} , others V_{IL} or V_{IH}	00EEh (M29W400DT) 00EFh (M29W400DB)

1. X = V_{IL} or V_{IH} .

4 Command interface

All Bus Write operations to the memory are interpreted by the command interface. Commands consist of one or more sequential Bus Write operations. Failure to observe a valid sequence of Bus Write operations will result in the memory returning to Read mode. The long command sequences are imposed to maximize data security.

The address used for the commands changes depending on whether the memory is in 16-bit or 8-bit mode. See either [Table 5](#), or [Table 6](#), depending on the configuration that is being used, for a summary of the commands.

4.1 Read/Reset command

The Read/Reset command returns the memory to its Read mode where it behaves like a ROM or EPROM, unless otherwise stated. It also resets the errors in the Status Register. Either one or three Bus Write operations can be used to issue the Read/Reset command.

The Read/Reset command can be issued, between Bus Write cycles before the start of a program or erase operation, to return the device to Read mode. Once the program or erase operation has started the Read/Reset command is no longer accepted. The Read/Reset command will not abort an Erase operation when issued while in Erase Suspend.

4.2 Auto Select command

The Auto Select command is used to read the manufacturer code, the device code and the Block Protection status. Three consecutive Bus Write operations are required to issue the Auto Select command. Once the Auto Select command is issued the memory remains in Auto Select mode until another command is issued.

From the Auto Select mode the manufacturer code can be read using a Bus Read operation with $A0 = V_{IL}$ and $A1 = V_{IL}$. The other address bits may be set to either V_{IL} or V_{IH} . The manufacturer code for Numonyx is 0020h.

The device code can be read using a Bus Read operation with $A0 = V_{IH}$ and $A1 = V_{IL}$. The other address bits may be set to either V_{IL} or V_{IH} . The device code for the M29W400DT is 00EEh and for the M29W400DB is 00EFh.

The Block Protection status of each block can be read using a Bus Read operation with $A0 = V_{IL}$, $A1 = V_{IH}$, and A12-A17 specifying the address of the block. The other address bits may be set to either V_{IL} or V_{IH} . If the addressed block is protected then 01h is output on Data inputs/outputs DQ0-DQ7, otherwise 00h is output.

4.3 Program command

The Program command can be used to program a value to one address in the memory array at a time. The command requires four Bus Write operations, the final write operation latches the address and data and starts the Program/Erase controller.

If the address falls in a protected block then the Program command is ignored, the data remains unchanged. The Status Register is never read and no error condition is given.

During the program operation the memory will ignore all commands. It is not possible to issue any command to abort or pause the operation. Typical program times are given in [Table 4: Program, Erase times and Program, Erase endurance cycles](#). Bus Read operations during the program operation will output the Status Register on the Data inputs/outputs. See the section on the Status Register for more details.

After the program operation has completed the memory will return to the Read mode, unless an error has occurred. When an error occurs the memory will continue to output the Status Register. A Read/Reset command must be issued to reset the error condition and return to Read mode.

Note that the Program command cannot change a bit set at '0' back to '1'. One of the Erase commands must be used to set all the bits in a block or in the whole memory from '0' to '1'.

4.4 Unlock Bypass command

The Unlock Bypass command is used in conjunction with the Unlock Bypass Program command to program the memory. When the access time to the device is long (as with some EPROM programmers) considerable time saving can be made by using these commands. Three Bus Write operations are required to issue the Unlock Bypass command.

Once the Unlock Bypass command has been issued the memory will only accept the Unlock Bypass Program command and the Unlock Bypass Reset command. The memory can be read as if in Read mode.

4.5 Unlock Bypass Program command

The Unlock Bypass Program command can be used to program one address in memory at a time. The command requires two Bus Write operations, the final write operation latches the address and data and starts the Program/Erase controller.

The Program operation using the Unlock Bypass Program command behaves identically to the Program operation using the Program command. A protected block cannot be programmed; the operation cannot be aborted and the Status Register is read. Errors must be reset using the Read/Reset command, which leaves the device in Unlock Bypass mode. See the Program command for details on the behavior.

4.6 Unlock Bypass Reset command

The Unlock Bypass Reset command can be used to return to Read/Reset mode from Unlock Bypass mode. Two Bus Write operations are required to issue the Unlock Bypass Reset command. Read/Reset command does not exit from Unlock Bypass mode.

4.7 Chip Erase command

The Chip Erase command can be used to erase the entire chip. Six Bus Write operations are required to issue the Chip Erase command and start the Program/Erase controller.

If any blocks are protected then these are ignored and all the other blocks are erased. If all of the blocks are protected the Chip Erase operation appears to start but will terminate

within about 100 μ s, leaving the data unchanged. No error condition is given when protected blocks are ignored.

During the erase operation the memory will ignore all commands. It is not possible to issue any command to abort the operation. Typical chip erase times are given in [Table 4](#). All Bus Read operations during the Chip Erase operation will output the Status Register on the Data inputs/outputs. See the section on the Status Register for more details.

After the Chip Erase operation has completed the memory will return to the Read mode, unless an error has occurred. When an error occurs the memory will continue to output the Status Register. A Read/Reset command must be issued to reset the error condition and return to Read mode.

The Chip Erase command sets all of the bits in unprotected blocks of the memory to '1'. All previous data is lost.

4.8 Block Erase command

The Block Erase command can be used to erase a list of one or more blocks. Six Bus Write operations are required to select the first block in the list. Each additional block in the list can be selected by repeating the sixth Bus Write operation using the address of the additional block. The Block Erase operation starts the Program/Erase controller about 50 μ s after the last Bus Write operation. Once the Program/Erase controller starts it is not possible to select any more blocks. Each additional block must therefore be selected within 50 μ s of the last block. The 50 μ s timer restarts when an additional block is selected. The Status Register can be read after the sixth Bus Write operation. See the Status Register for details on how to identify if the Program/Erase controller has started the Block Erase operation.

If any selected blocks are protected then these are ignored and all the other selected blocks are erased. If all of the selected blocks are protected the Block Erase operation appears to start but will terminate within about 100 μ s, leaving the data unchanged. No error condition is given when protected blocks are ignored.

During the Block Erase operation the memory will ignore all commands except the Erase Suspend command. Typical block erase times are given in [Table 4](#). All Bus Read operations during the Block Erase operation will output the Status Register on the Data inputs/outputs. See the section on the Status Register for more details.

After the Block Erase operation has completed the memory will return to the Read mode, unless an error has occurred. When an error occurs the memory will continue to output the Status Register. A Read/Reset command must be issued to reset the error condition and return to Read mode.

The Block Erase command sets all of the bits in the unprotected selected blocks to '1'. All previous data in the selected blocks is lost.

4.9 Erase Suspend command

The Erase Suspend command may be used to temporarily suspend a Block Erase operation and return the memory to Read mode. The command requires one Bus Write operation.

The Program/Erase controller will suspend within the Erase Suspend Latency time after the Erase Suspend command is issued (see [Table 4](#) for numerical values). Once the

Program/Erase controller has stopped the memory will be set to Read mode and the Erase will be suspended. If the Erase Suspend command is issued during the period when the memory is waiting for an additional block (before the Program/Erase controller starts) then the Erase is suspended immediately and will start immediately when the Erase Resume command is issued. It is not possible to select any further blocks to erase after the Erase Resume.

During Erase Suspend it is possible to Read and Program cells in blocks that are not being erased; both Read and Program operations behave as normal on these blocks. If any attempt is made to program in a protected block or in the suspended block then the Program command is ignored and the data remains unchanged. The Status Register is not read and no error condition is given. Reading from blocks that are being erased will output the Status Register.

It is also possible to issue the Auto Select and Unlock Bypass commands during an Erase Suspend. The Read/Reset command must be issued to return the device to Read Array mode before the Resume command will be accepted.

4.10 Erase Resume command

The Erase Resume command must be used to restart the Program/Erase controller from Erase Suspend. An erase can be suspended and resumed more than once.

4.11 Block Protect and Chip Unprotect commands

Each block can be separately protected against accidental program or erase. The whole chip can be unprotected to allow the data inside the blocks to be changed.

Block Protect and Chip Unprotect operations are described in [Appendix B: Block protection](#).

Table 4. Program, Erase times and Program, Erase endurance cycles

Parameter	Min	Typ ⁽¹⁾⁽²⁾	Max ⁽²⁾	Unit
Chip Erase (all bits in the memory set to '0')		2.5		s
Chip Erase		6	12 ⁽³⁾	s
Block Erase (64 Kbytes)		0.8	1.6 ⁽⁴⁾	s
Program (byte or word)		10	200 ⁽³⁾	μs
Chip Program (byte by byte)		5.5	30 ⁽³⁾	s
Chip Program (word by word)		2.8	15 ⁽³⁾	s
Erase Suspend latency time		18	25 ⁽⁴⁾	μs
Program/Erase cycles (per block)	100,000			cycles
Data retention	20			years

1. Typical values measured at room temperature and nominal voltages.
2. Sampled, but not 100% tested.
3. Maximum value measured at worst case conditions for both temperature and V_{CC} after 100,000 Program/Erase cycles.
4. Maximum value measured at worst case conditions for both temperature and V_{CC} .

Table 5. Commands, 16-bit mode, $\overline{\text{BYTE}} = V_{IH}^{(1)}$

Command	Length	Bus Write operations											
		1st		2nd		3rd		4th		5th		6th	
		Addr	Data	Addr	Data	Addr	Data	Addr	Data	Addr	Data	Addr	Data
Read/Reset	1	X	F0										
	3	555	AA	2AA	55	X	F0						
Auto Select	3	555	AA	2AA	55	555	90						
Program	4	555	AA	2AA	55	555	A0	PA	PD				
Unlock Bypass	3	555	AA	2AA	55	555	20						
Unlock Bypass Program	2	X	A0	PA	PD								
Unlock Bypass Reset	2	X	90	X	00								
Chip Erase	6	555	AA	2AA	55	555	80	555	AA	2AA	55	555	10
Block Erase	6+	555	AA	2AA	55	555	80	555	AA	2AA	55	BA	30
Erase Suspend	1	X	B0										
Erase Resume	1	X	30										

1. X Don't care, PA Program Address, PD Program Data, BA Any address in the block. All values in the table are in hexadecimal. The command interface only uses A-1: A0-A10 and DQ0-DQ7 to verify the commands; A11-A17, DQ8-DQ14 and DQ15 are Don't care. DQ15A-1 is A-1 when BYTE is V_{IL} or DQ15 when BYTE is V_{IH} .

Table 6. Commands, 8-bit mode, $\overline{\text{BYTE}} = V_{IL}^{(1)}$

Command	Length	Bus Write operations											
		1st		2nd		3rd		4th		5th		6th	
		Addr	Data	Addr	Data	Addr	Data	Addr	Data	Addr	Data	Addr	Data
Read/Reset	1	X	F0										
	3	AAA	AA	555	55	X	F0						
Auto Select	3	AAA	AA	555	55	AAA	90						
Program	4	AAA	AA	555	55	AAA	A0	PA	PD				
Unlock Bypass	3	AAA	AA	555	55	AAA	20						
Unlock Bypass Program	2	X	A0	PA	PD								
Unlock Bypass Reset	2	X	90	X	00								
Chip Erase	6	AAA	AA	555	55	AAA	80	AAA	AA	555	55	AAA	10
Block Erase	6+	AAA	AA	555	55	AAA	80	AAA	AA	555	55	BA	30
Erase Suspend	1	X	B0										
Erase Resume	1	X	30										

1. X Don't care, PA Program Address, PD Program Data, BA Any address in the block. All values in the table are in hexadecimal. The command interface only uses A-1: A0-A10 and DQ0-DQ7 to verify the commands; A11-A17, DQ8-DQ14 and DQ15 are Don't care. DQ15A-1 is A-1 when BYTE is V_{IL} or DQ15 when BYTE is V_{IH} .

5 Status Register

Bus Read operations from any address always read the Status Register during Program and Erase operations. It is also read during Erase Suspend when an address within a block being erased is accessed.

The bits in the Status Register are summarized in [Table 7: Status Register bits](#).

5.1 Data Polling bit (DQ7)

The Data Polling bit can be used to identify whether the Program/Erase controller has successfully completed its operation or if it has responded to an Erase Suspend. The Data Polling bit is output on DQ7 when the Status Register is read.

During Program operations the Data Polling bit outputs the complement of the bit being programmed to DQ7. After successful completion of the Program operation the memory returns to Read mode and Bus Read operations from the address just programmed output DQ7, not its complement.

During Erase operations the Data Polling bit outputs '0', the complement of the erased state of DQ7. After successful completion of the Erase operation the memory returns to Read mode.

In Erase Suspend mode the Data Polling bit will output a '1' during a Bus Read operation within a block being erased. The Data Polling bit will change from a '0' to a '1' when the Program/Erase controller has suspended the Erase operation.

[Figure 7: Data polling flowchart](#), gives an example of how to use the Data Polling bit. A valid address is the address being programmed or an address within the block being erased.

5.2 Toggle bit (DQ6)

The Toggle bit can be used to identify whether the Program/Erase controller has successfully completed its operation or if it has responded to an Erase Suspend. The Toggle bit is output on DQ6 when the Status Register is read.

During Program and Erase operations the Toggle bit changes from '0' to '1' to '0', etc., with successive Bus Read operations at any address. After successful completion of the operation the memory returns to Read mode.

During Erase Suspend mode the Toggle bit will output when addressing a cell within a block being erased. The Toggle bit will stop toggling when the Program/Erase controller has suspended the Erase operation.

If any attempt is made to erase a protected block, the operation is aborted, no error is signalled and DQ6 toggles for approximately 100 μ s. If any attempt is made to program a protected block or a suspended block, the operation is aborted, no error is signalled and DQ6 toggles for approximately 1 μ s.

[Figure 8: Data toggle flowchart](#), gives an example of how to use the Data Toggle bit.

5.3 Error bit (DQ5)

The Error bit can be used to identify errors detected by the Program/Erase controller. The Error bit is set to '1' when a Program, Block Erase or Chip Erase operation fails to write the correct data to the memory. If the Error bit is set a Read/Reset command must be issued before other commands are issued. The Error bit is output on DQ5 when the Status Register is read.

Note that the Program command cannot change a bit set to '0' back to '1' and attempting to do so will set DQ5 to '1'. A Bus Read operation to that address will show the bit is still '0'. One of the Erase commands must be used to set all the bits in a block or in the whole memory from '0' to '1'

5.4 Erase Timer bit (DQ3)

The Erase Timer bit can be used to identify the start of Program/Erase controller operation during a Block Erase command. Once the Program/Erase controller starts erasing, the Erase Timer bit is set to '1'. Before the Program/Erase controller starts the Erase Timer bit is set to '0' and additional blocks to be erased may be written to the command interface. The Erase Timer bit is output on DQ3 when the Status Register is read.

5.5 Alternative Toggle bit (DQ2)

The Alternative Toggle bit can be used to monitor the Program/Erase controller during Erase operations. The Alternative Toggle bit is output on DQ2 when the Status Register is read.

During Chip Erase and Block Erase operations the Toggle bit changes from '0' to '1' to '0', etc., with successive Bus Read operations from addresses within the blocks being erased. A protected block is treated the same as a block not being erased. Once the operation completes the memory returns to Read mode.

During Erase Suspend the Alternative Toggle bit changes from '0' to '1' to '0', etc. with successive Bus Read operations from addresses within the blocks being erased. Bus Read operations to addresses within blocks not being erased will output the memory cell data as if in Read mode.

After an Erase operation that causes the Error bit to be set the Alternative Toggle bit can be used to identify which block or blocks have caused the error. The Alternative Toggle bit changes from '0' to '1' to '0', etc. with successive Bus Read operations from addresses within blocks that have not erased correctly. The Alternative Toggle bit does not change if the addressed block has erased correctly.

Table 7. Status Register bits⁽¹⁾

Operation	Address	DQ7	DQ6	DQ5	DQ3	DQ2	R \bar{B}
Program	Any address	$\overline{DQ7}$	Toggle	0	–	–	0
Program during Erase Suspend	Any address	$\overline{DQ7}$	Toggle	0	–	–	0
Program Error	Any address	$\overline{DQ7}$	Toggle	1	–	–	0
Chip Erase	Any address	0	Toggle	0	1	Toggle	0

Table 7. Status Register bits⁽¹⁾ (continued)

Operation	Address	DQ7	DQ6	DQ5	DQ3	DQ2	\overline{RB}
Block Erase before timeout	Erasing block	0	Toggle	0	0	Toggle	0
	Non-erasing block	0	Toggle	0	0	No Toggle	0
Block Erase	Erasing block	0	Toggle	0	1	Toggle	0
	Non-erasing block	0	Toggle	0	1	No Toggle	0
Erase Suspend	Erasing block	1	No Toggle	0	–	Toggle	1
	Non-erasing block	Data read as normal					
Erase Error	Good block address	0	Toggle	1	1	No Toggle	0
	Faulty block address	0	Toggle	1	1	Toggle	0

1. Unspecified data bits should be ignored.

Figure 7. Data polling flowchart

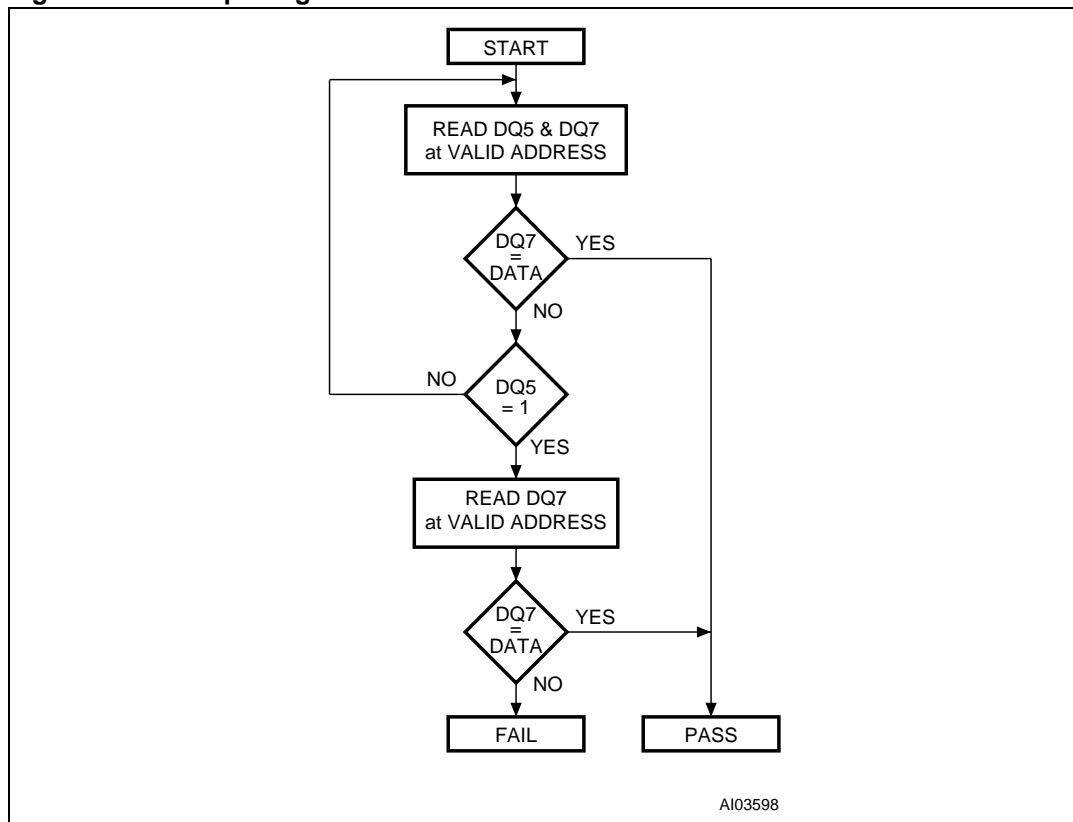
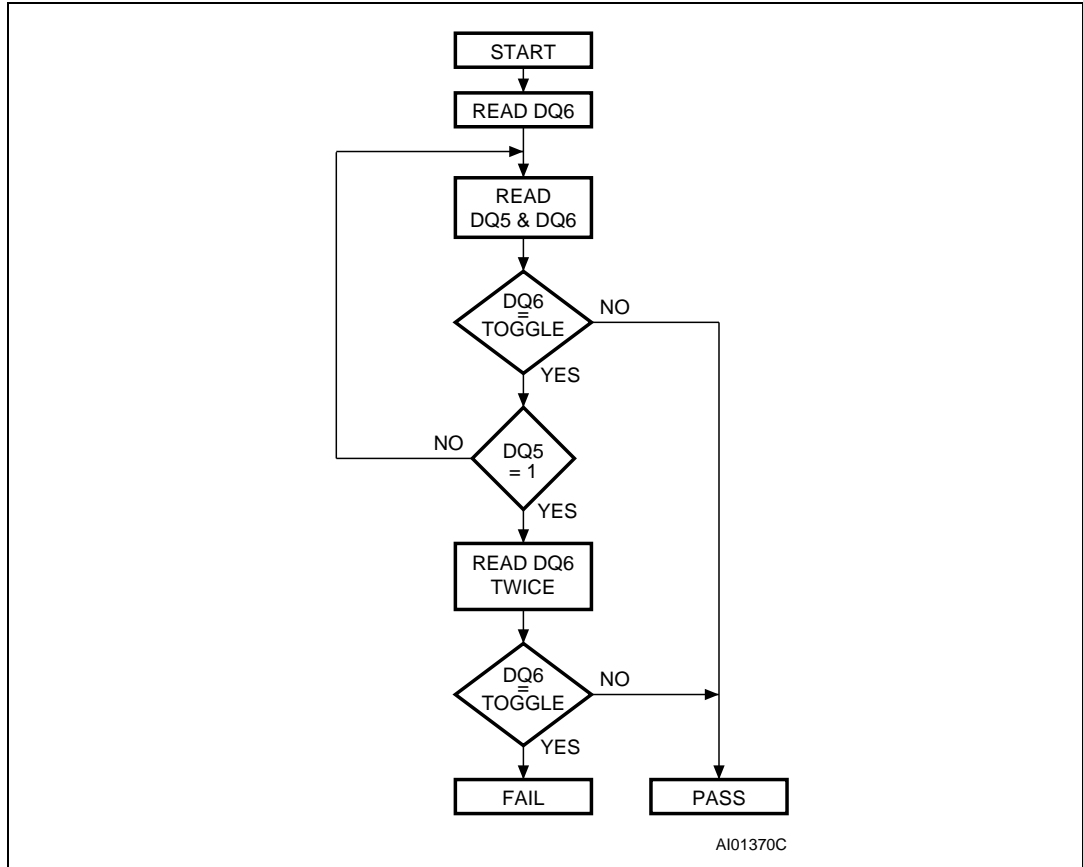

Figure 8. Data toggle flowchart



6 Maximum rating

Stressing the device above the rating listed in [Table 8: Absolute maximum ratings](#) may cause permanent damage to the device. Exposure to absolute maximum rating conditions for extended periods may affect device reliability. These are stress ratings only and operation of the device at these or any other conditions above those indicated in the operating sections of this specification is not implied. Refer also to the Numonyx SURE Program and other relevant quality documents.

Table 8. Absolute maximum ratings

Symbol	Parameter	Min	Max	Unit
T_{BIAS}	Temperature under bias	-50	125	°C
T_{STG}	Storage temperature	-65	150	°C
T_{LEAD}	Lead temperature during soldering		(1)	°C
V_{IO}	Input or output voltage ⁽²⁾⁽³⁾	-0.6	$V_{CC}+0.6$	V
V_{CC}	Supply voltage	-0.6	4	V
V_{ID}	Identification voltage	-0.6	13.5	V

1. Compliant with the JEDEC Std J-STD-020B (for small body, Sn-Pb or Pb assembly), the Numonyx RoHS specification, and the European directive on Restrictions on Hazardous Substances (RoHS) 2002/95/EU.
2. Minimum voltage may undershoot to -2 V during transition and for less than 20 ns during transitions.
3. Maximum voltage may overshoot to $V_{CC}+2$ V during transition and for less than 20 ns during transitions.

7 DC and AC parameters

This section summarizes the operating measurement conditions, and the DC and AC characteristics of the device. The parameters in the DC and AC characteristics tables that follow, are derived from tests performed under the measurement conditions summarized in [Table 9: Operating and AC measurement conditions](#). Designers should check that the operating conditions in their circuit match the operating conditions when relying on the quoted parameters.

Table 9. Operating and AC measurement conditions

Parameter	M29W400D						Unit
	45		55		70		
	Min	Max	Min	Max	Min	Max	
V_{CC} supply voltage	3.0	3.6	2.7	3.6	2.7	3.6	V
Ambient operating temperature (range 6)	-40	85	-40	85	-40	85	°C
Ambient operating temperature (range 1)	0	70	0	70	0	70	
Load capacitance (C_L)	30		30		100		pF
Input rise and fall times		10		10		10	ns
Input pulse voltages	0 to V_{CC}		0 to V_{CC}		0 to V_{CC}		V
Input and output timing ref. voltages	$V_{CC}/2$		$V_{CC}/2$		$V_{CC}/2$		V

Figure 9. AC measurement I/O waveform

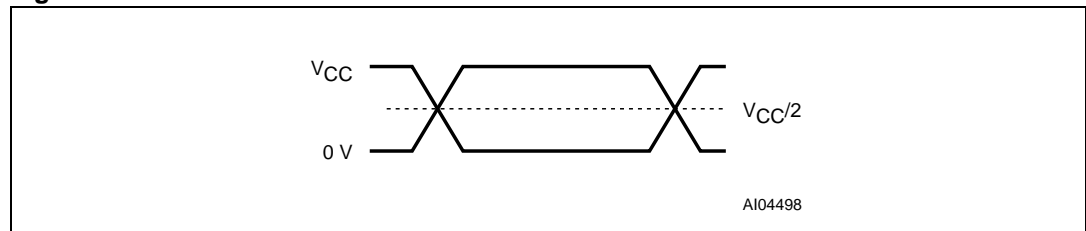

Figure 10. AC measurement load circuit

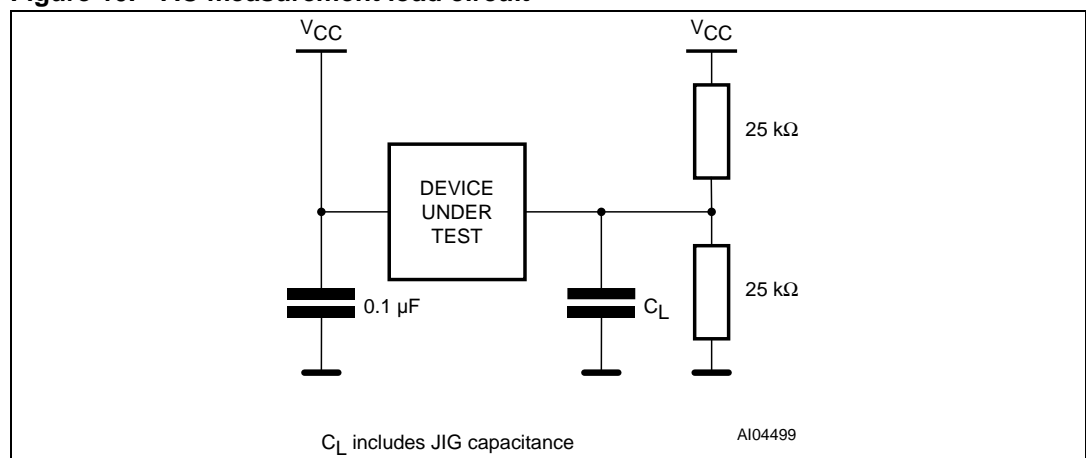

Table 10. Device capacitance⁽¹⁾

Symbol	Parameter	Test Condition	Min	Max	Unit
C _{IN}	Input capacitance	V _{IN} = 0 V		6	pF
C _{OUT}	Output capacitance	V _{OUT} = 0 V		12	pF

1. Sampled only, not 100% tested.

Table 11. DC characteristics

Symbol	Parameter	Test condition	Min	Max	Unit
I _{LI}	Input Leakage current	0 V ≤ V _{IN} ≤ V _{CC}		±1	μA
I _{LO}	Output Leakage current	0 V ≤ V _{OUT} ≤ V _{CC}		±1	μA
I _{CC1}	Supply current (Read)	$\bar{E} = V_{IL}, \bar{G} = V_{IH},$ f = 6 MHz		10	mA
I _{CC2}	Supply current (Standby)	$\bar{E} = V_{CC} \pm 0.2 V,$ $\bar{R}\bar{P} = V_{CC} \pm 0.2 V$		100	μA
I _{CC3} ⁽¹⁾	Supply current (Program/Erase)	Program/Erase controller active		20	mA
V _{IL}	Input Low voltage		-0.5	0.8	V
V _{IH}	Input High voltage		0.7V _{CC}	V _{CC} + 0.3	V
V _{OL}	Output Low voltage	I _{OL} = 1.8 mA		0.45	V
V _{OH}	Output High voltage	I _{OH} = -100 μA	V _{CC} - 0.4		V
V _{ID}	Identification voltage		11.5	12.5	V
I _{ID}	Identification current	A9 = V _{ID}		100	μA
V _{LKO}	Program/Erase Lockout supply voltage		1.8	2.3	V

1. Sampled only, not 100% tested.

Figure 11. Read mode AC waveforms

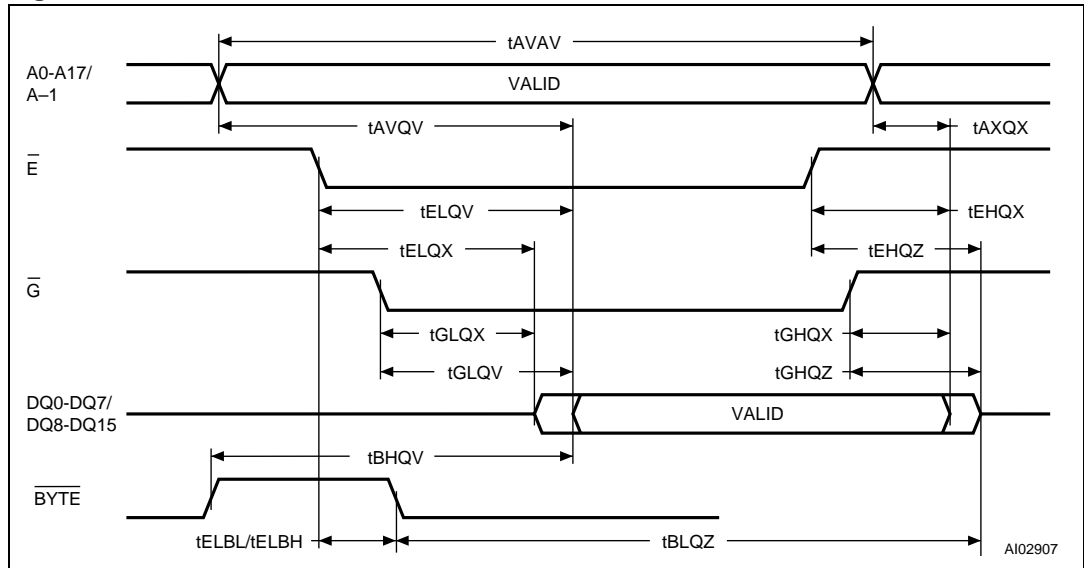

Table 12. Read AC characteristics

Symbol	Alt	Parameter	Test condition		M29W400D			Unit
					45	55	70	
t_{AVAV}	t_{RC}	Address Valid to Next Address Valid	$\overline{E} = V_{IL},$ $\overline{G} = V_{IL}$	Min	45	55	70	ns
t_{AVQV}	t_{ACC}	Address Valid to Output Valid	$\overline{E} = V_{IL},$ $\overline{G} = V_{IL}$	Max	45	55	70	ns
$t_{ELQX}^{(1)}$	t_{LZ}	Chip Enable Low to Output Transition	$\overline{G} = V_{IL}$	Min	0	0	0	ns
t_{ELQV}	t_{CE}	Chip Enable Low to Output Valid	$\overline{G} = V_{IL}$	Max	45	55	70	ns
$t_{GLQX}^{(1)}$	t_{OLZ}	Output Enable Low to Output Transition	$\overline{E} = V_{IL}$	Min	0	0	0	ns
t_{GLQV}	t_{OE}	Output Enable Low to Output Valid	$\overline{E} = V_{IL}$	Max	25	30	35	ns
$t_{EHQZ}^{(1)}$	t_{HZ}	Chip Enable High to Output Hi-Z	$\overline{G} = V_{IL}$	Max	20	25	30	ns
$t_{GHQZ}^{(1)}$	t_{DF}	Output Enable High to Output Hi-Z	$\overline{E} = V_{IL}$	Max	20	25	30	ns
t_{EHQX} t_{GHQX} t_{AXQX}	t_{OH}	Chip Enable, Output Enable or Address Transition to Output Transition		Min	0	0	0	ns
t_{ELBL} t_{ELBH}	t_{ELFL} t_{ELFH}	Chip Enable to \overline{BYTE} Low or High		Max	5	5	5	ns
t_{BLQZ}	t_{FLQZ}	\overline{BYTE} Low to Output Hi-Z		Max	25	25	30	ns
t_{BHQV}	t_{FHQV}	\overline{BYTE} High to Output Valid		Max	30	30	40	ns

1. Sampled only, not 100% tested.

Figure 12. Write AC waveforms, Write Enable controlled

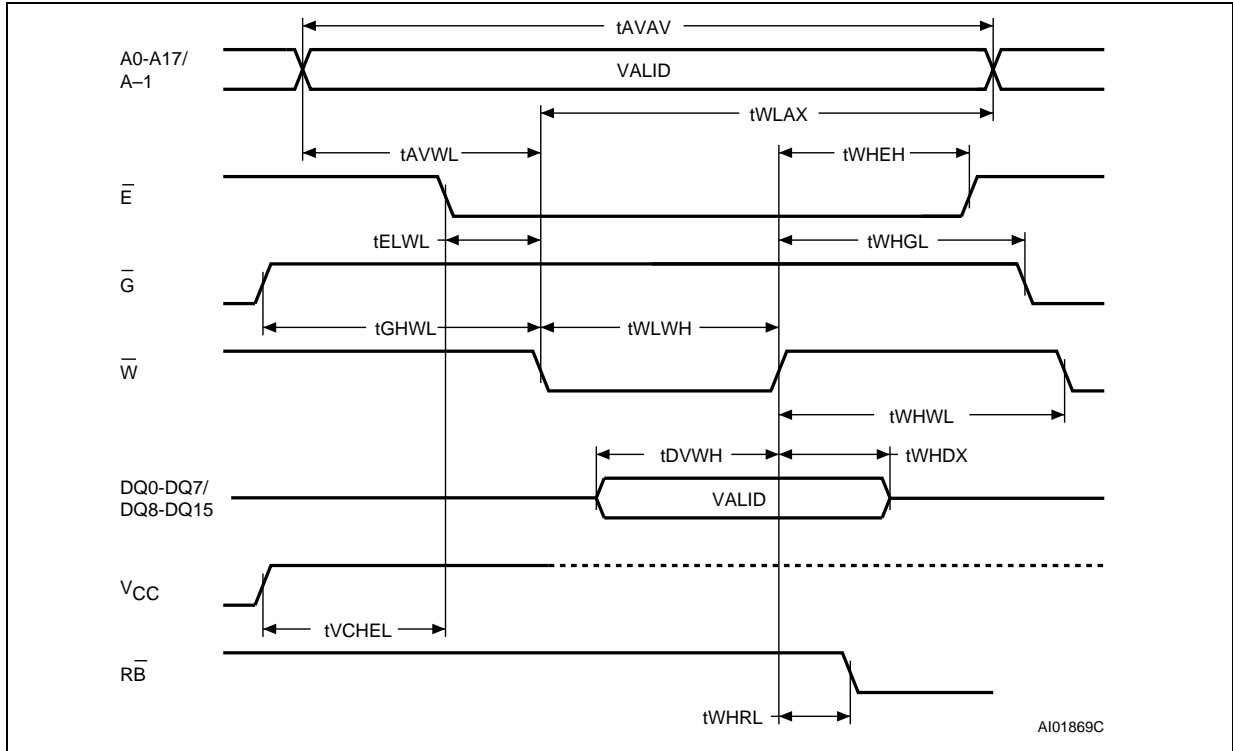
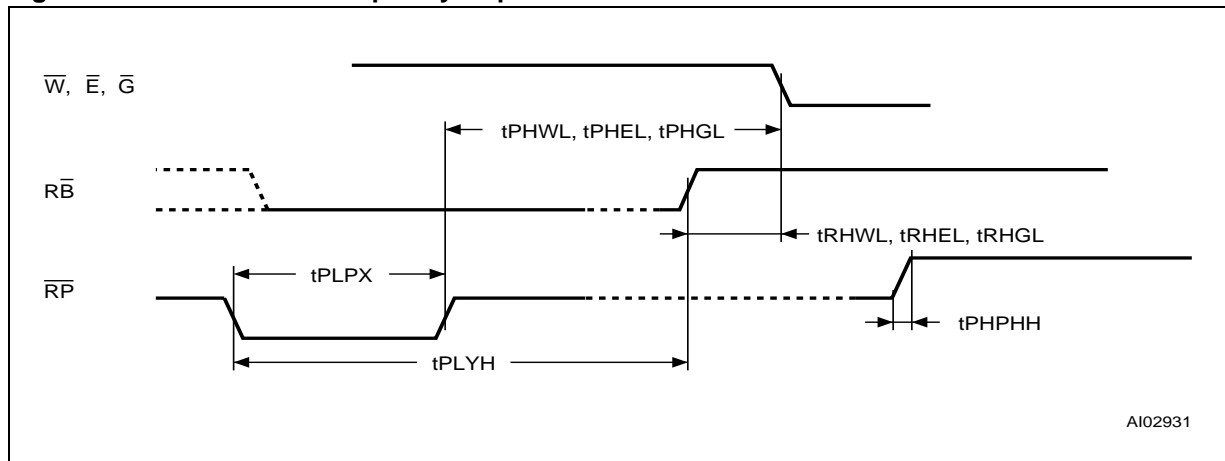

Table 13. Write AC characteristics, Write Enable controlled

Symbol	Alt	Parameter		M29W400D			Unit
				45	55	70	
t_{AVAV}	t_{WC}	Address Valid to Next Address Valid	Min	45	55	70	ns
t_{ELWL}	t_{CS}	Chip Enable Low to Write Enable Low	Min	0	0	0	ns
t_{WLWH}	t_{WP}	Write Enable Low to Write Enable High	Min	30	30	30	ns
t_{DVWH}	t_{DS}	Input Valid to Write Enable High	Min	25	30	45	ns
t_{WHDX}	t_{DH}	Write Enable High to Input Transition	Min	0	0	0	ns
t_{WHEH}	t_{CH}	Write Enable High to Chip Enable High	Min	0	0	0	ns
t_{WHWL}	t_{WPH}	Write Enable High to Write Enable Low	Min	30	30	30	ns
t_{AVWL}	t_{AS}	Address Valid to Write Enable Low	Min	0	0	0	ns
t_{WLAX}	t_{AH}	Write Enable Low to Address Transition	Min	40	45	45	ns
t_{GHWL}		Output Enable High to Write Enable Low	Min	0	0	0	ns
t_{WHGL}	t_{OEHL}	Write Enable High to Output Enable Low	Min	0	0	0	ns
$t_{WHRL}^{(1)}$	t_{BUSY}	Program/Erase Valid to \overline{RB} Low	Max	30	30	35	ns
t_{VCHL}	t_{VCS}	V_{CC} High to Chip Enable Low	Min	50	50	50	μ s

1. Sampled only, not 100% tested.

Figure 14. Reset/Block Temporary Unprotect AC waveforms



AI02931

Table 15. Reset/Block Temporary Unprotect AC characteristics

Symbol	Alt	Parameter	M29W400D			Unit	
			45	55	70		
$t_{PHWL}^{(1)}$ $t_{PHEL}^{(1)}$ $t_{PHGL}^{(1)}$	t_{RH}	\overline{RP} High to Write Enable Low, Chip Enable Low, Output Enable Low	Min	50	50	50	ns
$t_{RHWL}^{(1)}$ $t_{RHEL}^{(1)}$ $t_{RHGL}^{(1)}$	t_{RB}	\overline{RB} High to Write Enable Low, Chip Enable Low, Output Enable Low	Min	0	0	0	ns
t_{PLPX}	t_{RP}	\overline{RP} Pulse width	Min	500	500	500	ns
$t_{PLYH}^{(1)}$	t_{READY}	\overline{RP} Low to Read mode	Max	10	10	10	μ s
$t_{PHPHH}^{(1)}$	t_{VIDR}	\overline{RP} Rise time to V_{ID}	Min	500	500	500	ns

1. Sampled only, not 100% tested.

8 Package mechanical

Figure 15. SO44 - 44 lead plastic small outline, 525 mils body width, package outline

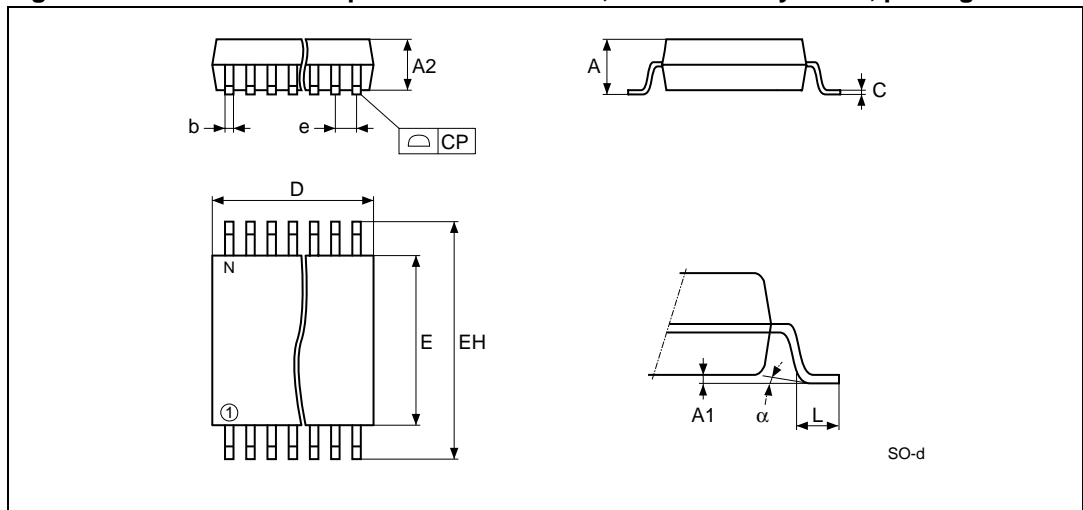

1. Drawing is not to scale.

Table 16. SO44 – 44 lead plastic small outline, 525 mils body width, package mechanical data

Symbol	millimeters			inches		
	Typ	Min	Max	Typ	Min	Max
A			2.80			0.110
A1		0.10			0.004	
A2	2.30	2.20	2.40	0.091	0.087	0.094
b	0.40	0.35	0.50	0.016	0.014	0.020
C	0.15	0.10	0.20	0.006	0.004	0.008
CP			0.08			0.003
D	28.20	28.00	28.40	1.110	1.102	1.118
E	13.30	13.20	13.50	0.524	0.520	0.531
EH	16.00	15.75	16.25	0.630	0.620	0.640
e	1.27	–	–	0.050	–	–
L	0.80			0.031		
a			8			8
N	44			44		

Figure 16. TSOP48 – 48 lead plastic thin small outline, 12 x 20 mm, package outline

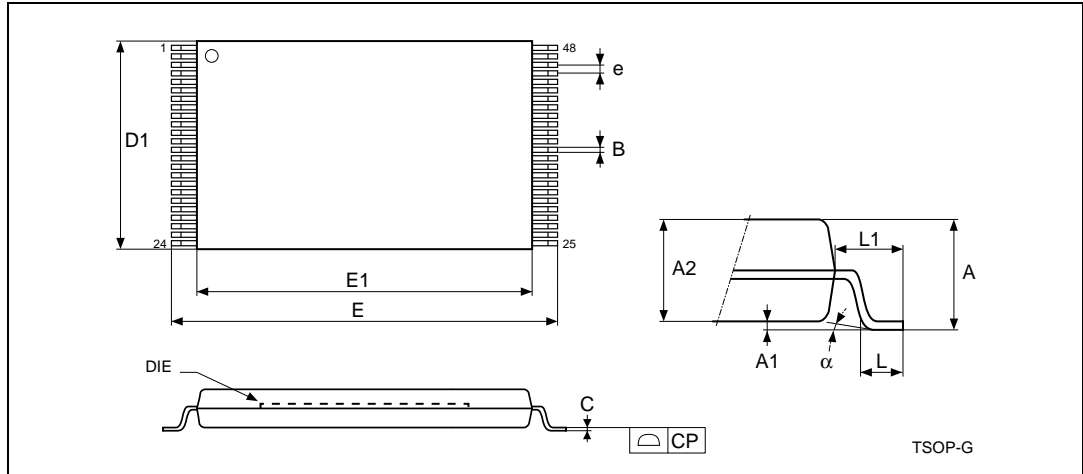

1. Drawing is not to scale.

Table 17. TSOP48 – 48 lead plastic thin small outline, 12 x 20 mm, package mechanical data

Symbol	millimeters			inches		
	Typ	Min	Max	Typ	Min	Max
A			1.20			0.047
A1	0.10	0.05	0.15	0.004	0.002	0.006
A2	1.00	0.95	1.05	0.039	0.037	0.041
B	0.22	0.17	0.27	0.009	0.007	0.011
C		0.10	0.21		0.004	0.008
CP			0.08			0.003
D1	12.00	11.90	12.10	0.472	0.468	0.476
E	20.00	19.80	20.20	0.787	0.779	0.795
E1	18.40	18.30	18.50	0.724	0.720	0.728
e	0.50	–	–	0.020	–	–
L	0.60	0.50	0.70	0.024	0.020	0.028
L1	0.80			0.031		
a	3	0	5	3	0	5

Figure 17. TFBGA48 6 x 9 mm, 6 x 8 active ball array, 0.80 mm pitch, bottom view package outline

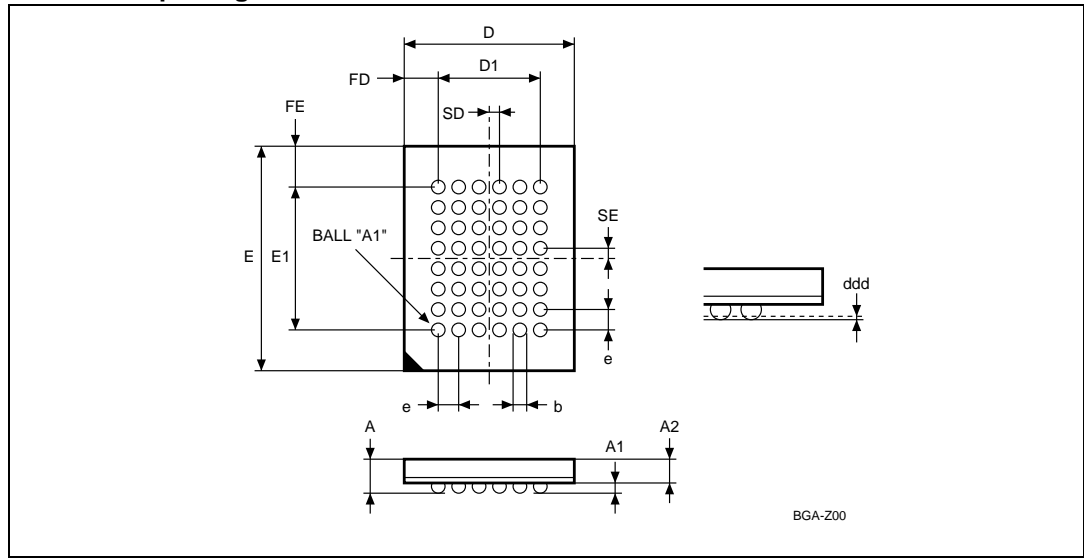

1. Drawing is not to scale.

Table 18. TFBGA48 6 x 9 mm, 6 x 8 active ball array, 0.80 mm pitch, package mechanical data

Symbol	millimeters			inches		
	Typ	Min	Max	Typ	Min	Max
A			1.20			0.047
A1		0.20			0.008	
A2			1.00			0.039
b	0.40	0.35	0.45	0.016	0.014	0.018
D	6.00	5.90	6.10	0.236	0.232	0.240
D1	4.00	–	–	0.157	–	–
ddd			0.10			0.004
E	9.00	8.90	9.10	0.354	0.350	0.358
e	0.80	–	–	0.031	–	–
E1	5.60	–	–	0.220	–	–
FD	1.00	–	–	0.039	–	–
FE	1.70	–	–	0.067	–	–
SD	0.40	–	–	0.016	–	–
SE	0.40	–	–	0.016	–	–

Figure 18. TFBGA48 6 x 8 mm, 6 x 8 active ball array, 0.80 mm pitch, bottom view package outline

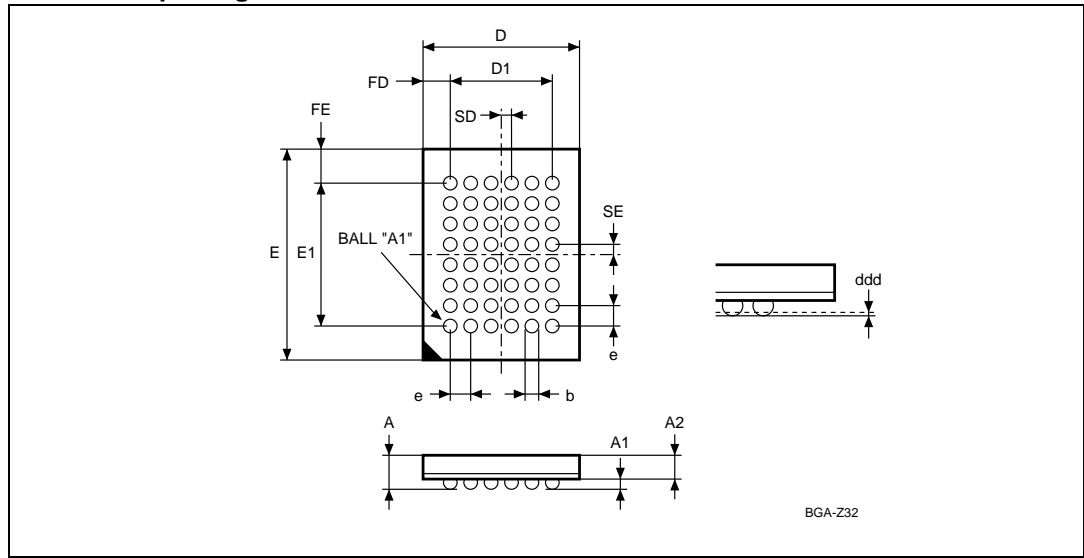

1. Drawing is not to scale.

Table 19. TFBGA48 6 x 8 mm, 6 x 8 active ball array, 0.80 mm pitch, package mechanical data

Symbol	millimeters			inches		
	Typ	Min	Max	Typ	Min	Max
A			1.20			0.047
A1		0.26			0.010	
A2			0.90			0.035
b		0.35	0.45		0.014	0.018
D	6.00	5.90	6.10	0.236	0.232	0.240
D1	4.00	–	–	0.157	–	–
ddd			0.10			0.004
E	8.00	7.90	8.10	0.315	0.311	0.319
E1	5.60	–	–	0.220	–	–
e	0.80	–	–	0.031	–	–
FD	1.00	–	–	0.039	–	–
FE	1.20	–	–	0.047	–	–
SD	0.40	–	–	0.016	–	–
SE	0.40	–	–	0.016	–	–

9 Part numbering

Table 20. Ordering information scheme

Example:	M29W400DT	55	N	6	T
Device type M29					
Operating voltage W = $V_{CC} = 2.7$ to 3.6 V					
Device Function 400D = 4 Mbit (512 K x 8 or 256 K x 16), boot block					
Array matrix T = Top boot B = Bottom boot					
Speed 45 = 45 ns 55 = 55 ns 70 = 70 ns					
Package M = SO44 N = TSOP48: 12 x 20 mm ZA = TFBGA48: 6 x 9 mm ZE = TFBGA48: 6 x 8 mm					
Temperature range 6 = -40 to 85 °C 3 ⁽¹⁾ = Automotive grade certified ⁽²⁾ (-40 to 125 °C) 1 = 0 to 70 °C					
Option Blank = Standard packing T = Tape & Reel packing E = RoHS package, standard packing F = RoHS package, Tape & Reel packing					

1. Automotive grade 3 part is available only for the speed class 55 ns, package type TSOP48, 12 x 20 mm, bottom configuration.
2. The part is qualified and tested according to the AEC-Q100 rev. G specifications.

Devices are shipped from the factory with the memory content bits erased to '1'.

For a list of available options (speed, package, etc.) or for further information on any aspect of this device, please contact the Numonyx Sales Office nearest to you.

Appendix A Block address table

Table 21. Top boot block addresses M29W400DT

#	Size (Kbytes)	Address range (x 8)	Address range (x 16)
10	16	7C000h-7FFFFh	3E000h-3FFFFh
9	8	7A000h-7BFFFh	3D000h-3DFFFh
8	8	78000h-79FFFh	3C000h-3CFFFh
7	32	70000h-77FFFh	38000h-3BFFFh
6	64	60000h-6FFFFh	30000h-37FFFh
5	64	50000h-5FFFFh	28000h-2FFFFh
4	64	40000h-4FFFFh	20000h-27FFFh
3	64	30000h-3FFFFh	18000h-1FFFFh
2	64	20000h-2FFFFh	10000h-17FFFh
1	64	10000h-1FFFFh	08000h-0FFFFh
0	64	00000h-0FFFFh	00000h-07FFFh

Table 22. Bottom boot block addresses M29W400DB

#	Size (Kbytes)	Address range (x 8)	Address range (x 16)
10	64	70000h-7FFFFh	38000h-3FFFFh
9	64	60000h-6FFFFh	30000h-37FFFh
8	64	50000h-5FFFFh	28000h-2FFFFh
7	64	40000h-4FFFFh	20000h-27FFFh
6	64	30000h-3FFFFh	18000h-1FFFFh
5	64	20000h-2FFFFh	10000h-17FFFh
4	64	10000h-1FFFFh	08000h-0FFFFh
3	32	08000h-0FFFFh	04000h-07FFFh
2	8	06000h-07FFFh	03000h-03FFFh
1	8	04000h-05FFFh	02000h-02FFFh
0	16	00000h-03FFFh	00000h-01FFFh

Appendix B Block protection

Block protection can be used to prevent any operation from modifying the data stored in the Flash. Each block can be protected individually. Once protected, Program and Erase operations on the block fail to change the data.

There are three techniques that can be used to control block protection, these are the programmer technique, the in-system technique and temporary unprotection. temporary unprotection is controlled by the Reset/Block Temporary Unprotection pin, \overline{RP} ; this is described in the [Section 2: Signal descriptions](#).

Unlike the command interface of the Program/Erase controller, the techniques for protecting and unprotecting blocks change between different Flash memory suppliers. For example, the techniques for AMD parts will not work on Numonyx parts. Care should be taken when changing drivers for one part to work on another.

B.1 Programmer technique

The programmer technique uses high (V_{ID}) voltage levels on some of the bus pins. These cannot be achieved using a standard microprocessor bus, therefore the technique is recommended only for use in programming equipment.

To protect a block follow the flowchart in [Figure 19: Programmer equipment block protect flowchart](#). To unprotect the whole chip it is necessary to protect all of the blocks first, then all blocks can be unprotected at the same time. To unprotect the chip follow [Figure 20: Programmer equipment chip unprotect flowchart](#). [Table 23: Programmer technique bus operations, \$BYTE = VIH\$ or \$VIL\$](#) , gives a summary of each operation.

The timing on these flowcharts is critical. Care should be taken to ensure that, where a pause is specified, it is followed as closely as possible. Do not abort the procedure before reaching the end. Chip Unprotect can take several seconds and a user message should be provided to show that the operation is progressing.

B.2 In-system technique

The in-system technique requires a high voltage level on the Reset/Blocks Temporary Unprotect pin, \overline{RP} . This can be achieved without violating the maximum ratings of the components on the microprocessor bus, therefore this technique is suitable for use after the Flash has been fitted to the system.

To protect a block follow the flowchart in [Figure 21: In-system equipment block protect flowchart](#). To unprotect the whole chip it is necessary to protect all of the blocks first, then all the blocks can be unprotected at the same time. To unprotect the chip follow [Figure 22: In-system equipment chip unprotect flowchart](#).

The timing on these flowcharts is critical. Care should be taken to ensure that, where a pause is specified, it is followed as closely as possible. Do not allow the microprocessor to service interrupts that will upset the timing and do not abort the procedure before reaching the end. Chip Unprotect can take several seconds and a user message should be provided to show that the operation is progressing.

Table 23. Programmer technique bus operations, $\overline{\text{BYTE}} = V_{\text{IH}}$ or V_{IL}

Operation	$\overline{\text{E}}$	$\overline{\text{G}}$	$\overline{\text{W}}$	Address inputs A0-A17	Data inputs/outputs DQ15A-1, DQ14-DQ0
Block Protect	V_{IL}	V_{ID}	V_{IL} pulse	A9 = V_{ID} , A12-A17 block address, others = X	X
Chip Unprotect	V_{ID}	V_{ID}	V_{IL} pulse	A9 = V_{ID} , A12 = V_{IH} , A15 = V_{IH} , others = X	X
Block Protection Verify	V_{IL}	V_{IL}	V_{IH}	A0 = V_{IL} , A1 = V_{IH} , A6 = V_{IL} , A9 = V_{ID} , A12-A17 block address, others = X	Pass = XX01h Retry = XX00h
Block Unprotection Verify	V_{IL}	V_{IL}	V_{IH}	A0 = V_{IL} , A1 = V_{IH} , A6 = V_{IH} , A9 = V_{ID} , A12-A17 block address, others = X	Retry = XX01h Pass = XX00h

Figure 19. Programmer equipment block protect flowchart

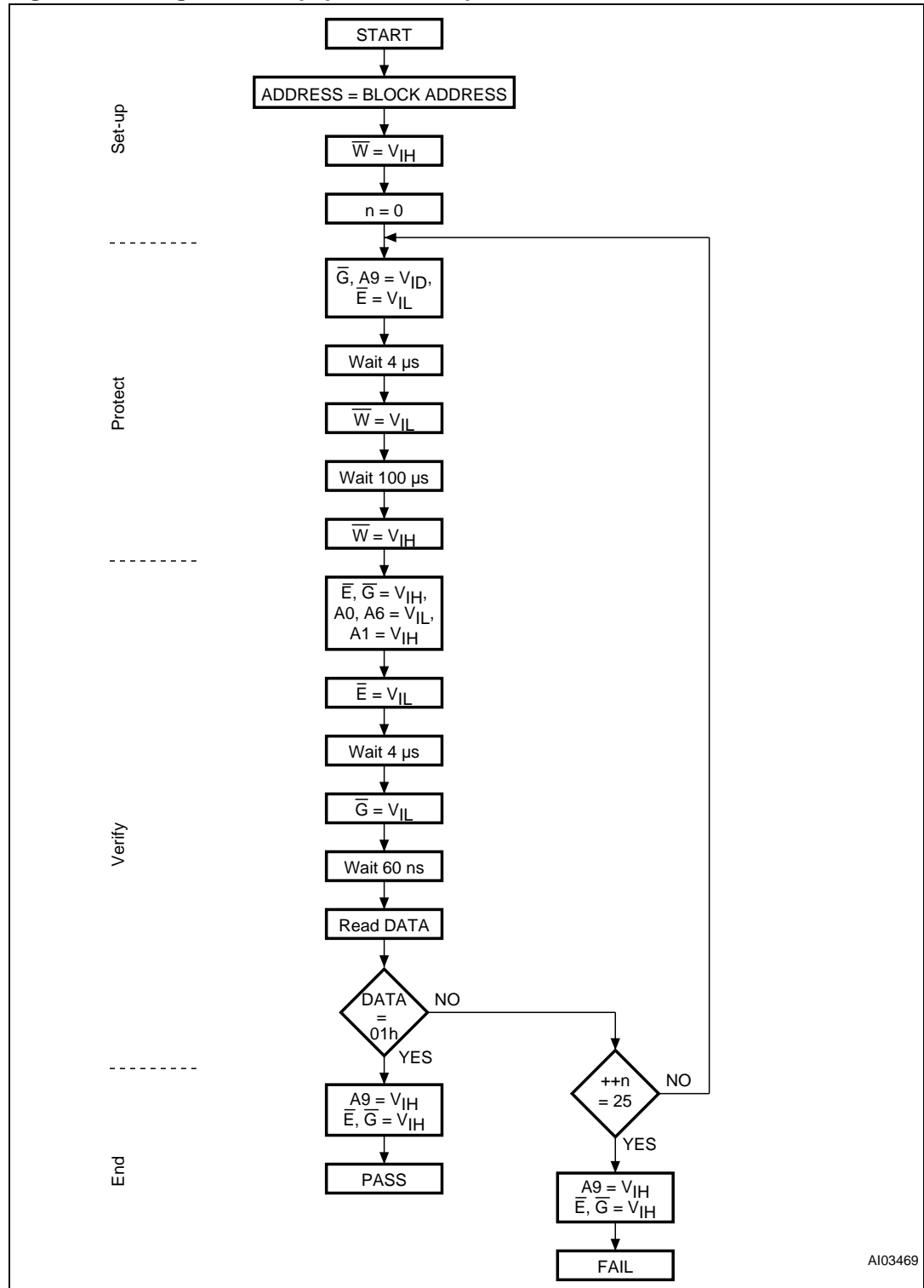

AI03469

Figure 20. Programmer equipment chip unprotect flowchart

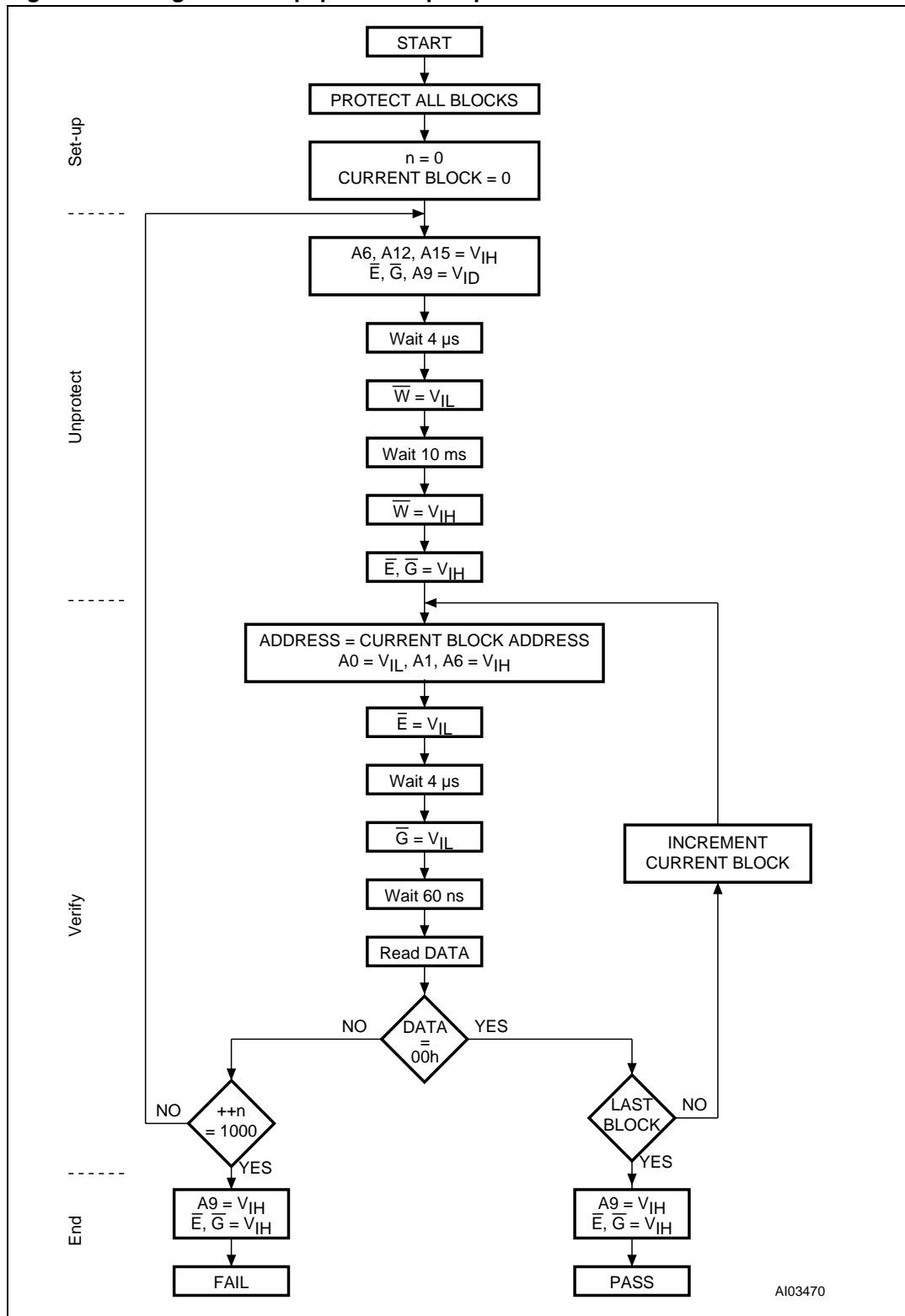

A103470

Figure 21. In-system equipment block protect flowchart

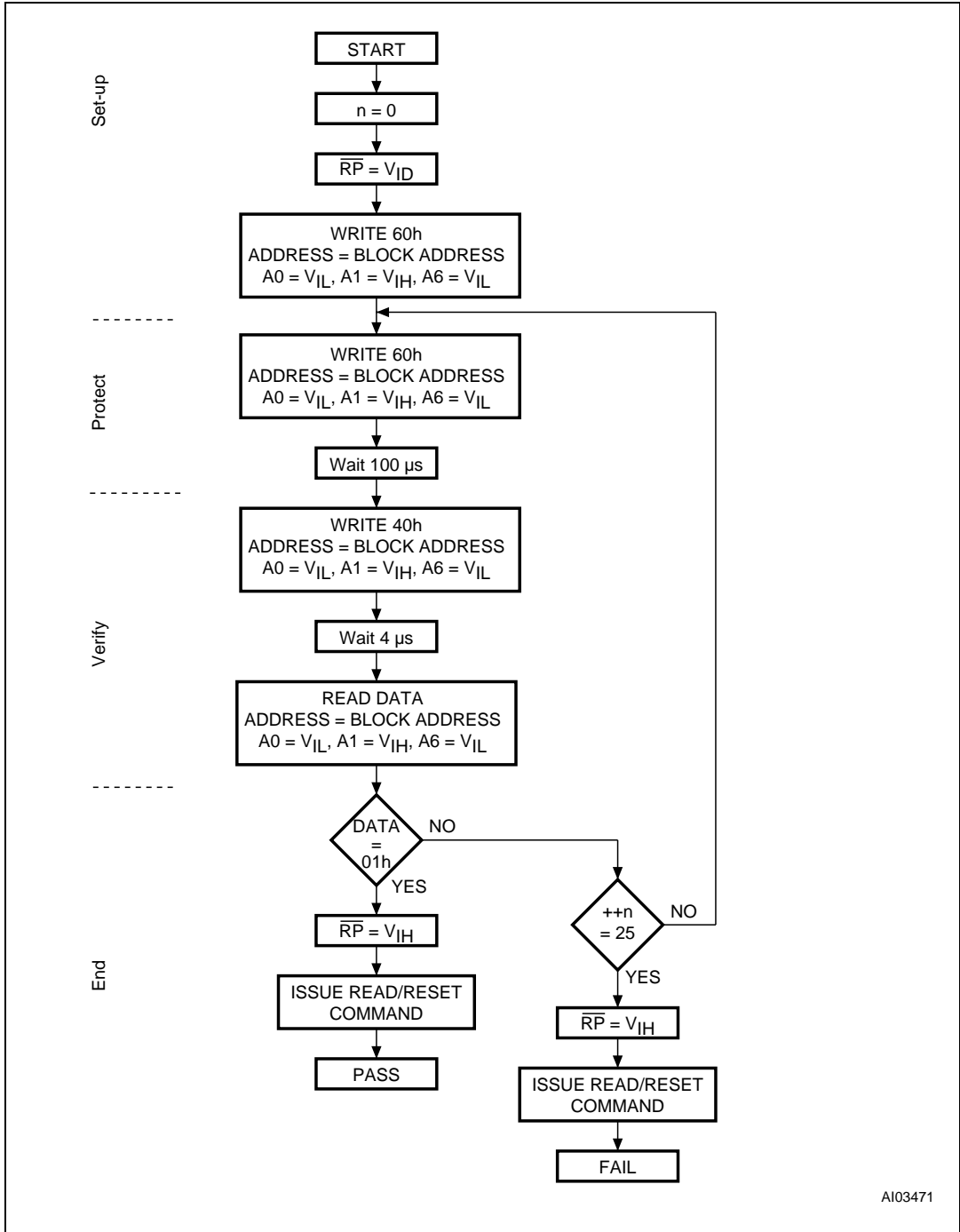

AI03471

Figure 22. In-system equipment chip unprotect flowchart

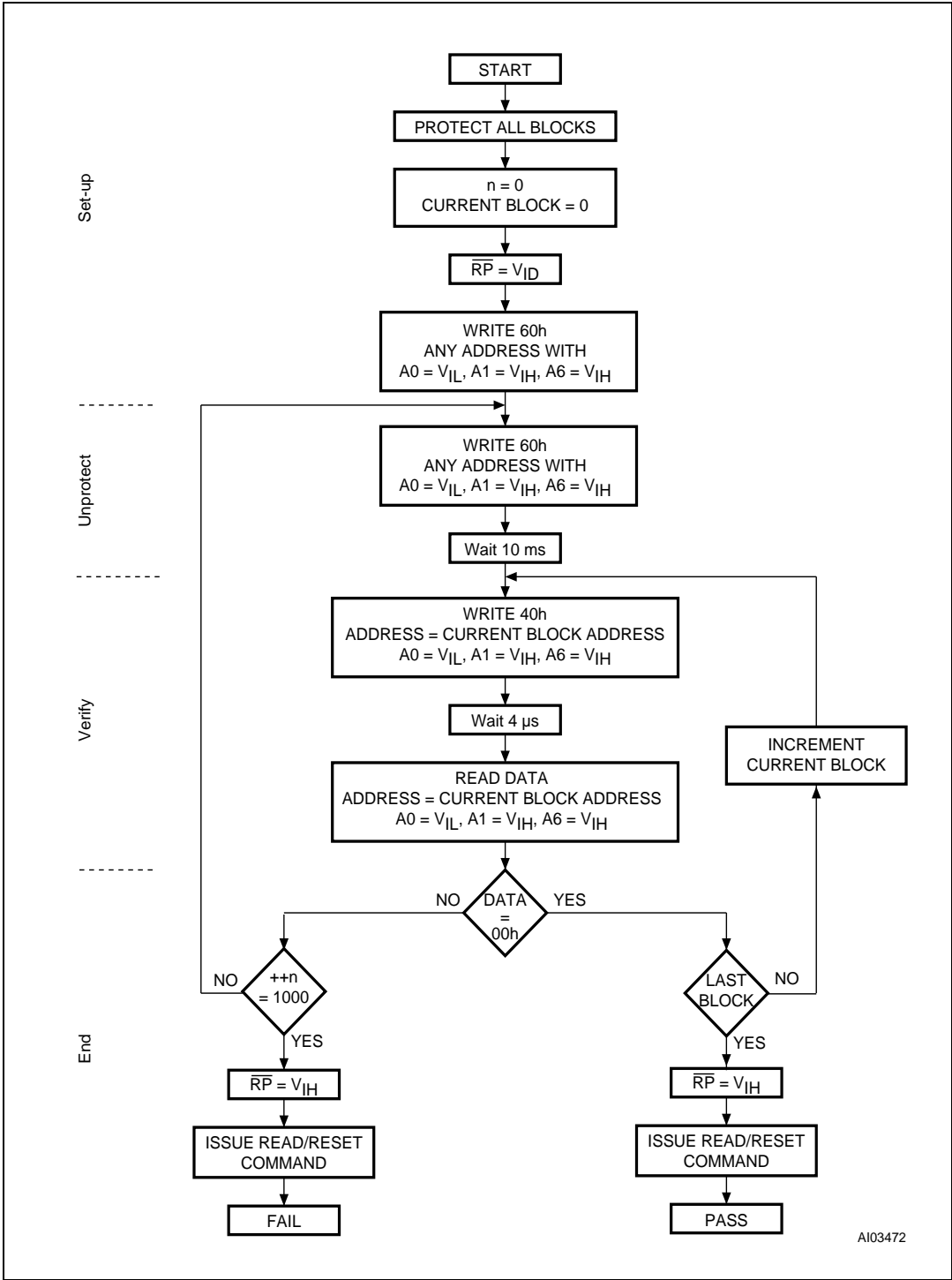

AI03472

10 Revision history

Table 24. Document revision history

Date	Revision	Changes
26-Jul-2002	01	Initial release
19-Feb-2003	2.0	Revision numbering modified: a minor revision will be indicated by incrementing the digit after the dot, and a major revision, by incrementing the digit before the dot (revision version 01 equals 1.0). Revision history moved to end of document. Typical after 100k W/E cycles column removed from Table 4: Program, Erase times and Program, Erase endurance cycles , Data retention and Erase Suspend latency time parameters added. Common Flash interface removed from datasheet. Lead-free package options E and F added to Table 20: Ordering information scheme . Document promoted from Product Preview to Preliminary Data status.
28-May-2003	2.1	t_{WLWH} and t_{ELEH} parameters modified for all speed classes in Table 13: Write AC characteristics, Write Enable controlled and Table 14: Write AC characteristics, Chip Enable controlled . Minor text changes. TSOP48 package updated (Figure 16 and Table 17).
30-Sep-2003	2.2	Document status changed to Full datasheet. TFBGA48 6 x 8 package added. T_{LEAD} parameter added in Table 8: Absolute maximum ratings .
6-Oct-2003	2.3	t_{GLQV} modified in Table 12: Read AC characteristics .
16-Jan-2004	3	\overline{RB} pin description corrected in Table : .
8-Jun-2004	4	Tape and Reel option updated in Table 20: Ordering information scheme . Lead-free packaging promotion updated in Section 1: Description , Section 6: Maximum rating and Section 9: Part numbering .
07-Aug-2007	5	RoHS text added in Section 1: Description . Updated options E and F in Table 20: Ordering information scheme . Small text changes.
10-Dec-2007	6	Applied Numonyx branding.
2-March 2009	7	Added Automotive Grade 3 part information to cover page and part ordering information.
7-April-2009	8	Revised \overline{BYTE} signal name from “output” to “input” in Table 1.: Signal names ; Revised Chip Erase signal value (maximum) in Table 4.: Program, Erase times and Program, Erase endurance cycles from 35 to 12 seconds. Revised Block Erase (64-Kbytes) signal value (maximum) in Table 4.: Program, Erase times and Program, Erase endurance cycles from 6 to 1.6 seconds.

Please Read Carefully:

INFORMATION IN THIS DOCUMENT IS PROVIDED IN CONNECTION WITH NUMONYX™ PRODUCTS. NO LICENSE, EXPRESS OR IMPLIED, BY ESTOPPEL OR OTHERWISE, TO ANY INTELLECTUAL PROPERTY RIGHTS IS GRANTED BY THIS DOCUMENT. EXCEPT AS PROVIDED IN NUMONYX'S TERMS AND CONDITIONS OF SALE FOR SUCH PRODUCTS, NUMONYX ASSUMES NO LIABILITY WHATSOEVER, AND NUMONYX DISCLAIMS ANY EXPRESS OR IMPLIED WARRANTY, RELATING TO SALE AND/OR USE OF NUMONYX PRODUCTS INCLUDING LIABILITY OR WARRANTIES RELATING TO FITNESS FOR A PARTICULAR PURPOSE, MERCHANTABILITY, OR INFRINGEMENT OF ANY PATENT, COPYRIGHT OR OTHER INTELLECTUAL PROPERTY RIGHT.

Numonyx products are not intended for use in medical, life saving, life sustaining, critical control or safety systems, or in nuclear facility applications.

Numonyx may make changes to specifications and product descriptions at any time, without notice.

Numonyx, B.V. may have patents or pending patent applications, trademarks, copyrights, or other intellectual property rights that relate to the presented subject matter. The furnishing of documents and other materials and information does not provide any license, express or implied, by estoppel or otherwise, to any such patents, trademarks, copyrights, or other intellectual property rights.

Designers must not rely on the absence or characteristics of any features or instructions marked "reserved" or "undefined." Numonyx reserves these for future definition and shall have no responsibility whatsoever for conflicts or incompatibilities arising from future changes to them.

Contact your local Numonyx sales office or your distributor to obtain the latest specifications and before placing your product order.

Copies of documents which have an order number and are referenced in this document, or other Numonyx literature may be obtained by visiting Numonyx's website at <http://www.numonyx.com>.



Numonyx StrataFlash is a trademark or registered trademark of Numonyx or its subsidiaries in the United States and other countries.

*Other names and brands may be claimed as the property of others.

Copyright © 2009, Numonyx, B.V., All Rights Reserved.

Looking for pricing, stock, or lifecycle information?

Click below to explore more details on WIN SOURCE:

-  [View M29W400DB70N1 on WIN SOURCE](#)
-  [Micron Technology Inc. Information](#)

Optimize Your Supply Chain with WIN SOURCE Solutions

-  Global Sourcing Solution
-  Obsolete Management
-  Cost Control Management
-  Shortage Management
-  Alternative Solution
-  Excess Inventory Management