



**THE DATASHEET OF  
M27W512-100K6TR**





## 512 Kbit (64 Kbit x8) low-voltage OTP EPROM

### Features

- 2.7 to 3.6 V supply voltage in read operation
- Access time: 100 ns
- Pin compatibility with M27C512
- Low power consumption
  - 15  $\mu$ A max Standby current
  - 15 mA max Active current at 5 MHz
- Programming time 100  $\mu$ s/byte
- High reliability CMOS technology
  - 2000 V ESD protection
  - 200 mA latch-up protection immunity
- Electronic signature
  - Manufacturer code: 20h
  - Device code: 3Dh
- ECOPACK<sup>®</sup> packages

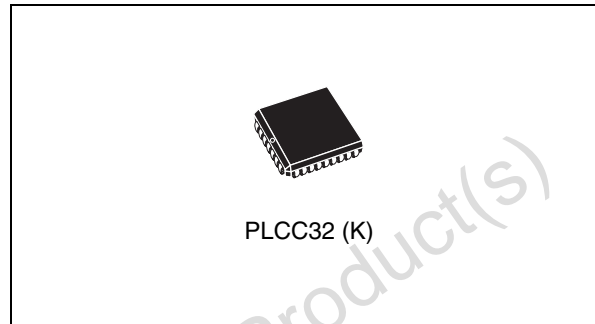

# Contents

<b>1</b>	<b>Description</b> .....	<b>5</b>
<b>2</b>	<b>Device operation</b> .....	<b>7</b>
2.1	Read mode .....	7
2.2	Standby mode .....	7
2.3	Two line output control .....	8
2.4	System considerations .....	8
2.5	Programming .....	9
2.6	PRESTO IIB programming algorithm .....	10
2.7	Program inhibit .....	10
2.8	Program verify .....	10
2.9	Electronic signature .....	10
<b>3</b>	<b>Maximum rating</b> .....	<b>11</b>
<b>4</b>	<b>DC and AC parameters</b> .....	<b>12</b>
<b>5</b>	<b>Package mechanical data</b> .....	<b>18</b>
<b>6</b>	<b>Part numbering</b> .....	<b>20</b>
<b>7</b>	<b>Revision history</b> .....	<b>21</b>

## List of tables

Table 1.	Signal names	6
Table 2.	Operating modes	7
Table 3.	Electronic signature	7
Table 4.	Absolute maximum ratings	11
Table 5.	AC measurement conditions.	12
Table 6.	Capacitance	13
Table 7.	Read mode DC characteristics	13
Table 8.	Read mode AC characteristics	14
Table 9.	Programming mode DC characteristics	15
Table 10.	Margin mode AC characteristics	15
Table 11.	Programming mode AC characteristics	16
Table 12.	PLCC32 - 32 lead plastic leaded chip carrier, package mechanical data.	19
Table 13.	Ordering information scheme	20
Table 14.	Document revision history	21

## List of figures

Figure 1.	Logic diagram . . . . .	5
Figure 2.	LCC connections . . . . .	6
Figure 3.	Programming flowchart . . . . .	9
Figure 4.	AC testing input output waveform . . . . .	12
Figure 5.	AC testing load circuit . . . . .	12
Figure 6.	Read mode AC waveforms . . . . .	14
Figure 7.	Margin mode AC waveforms . . . . .	16
Figure 8.	Programming and verify mode AC waveforms . . . . .	17
Figure 9.	PLCC32 - 32 lead plastic leaded chip carrier, package outline . . . . .	19

Obsolete Product(s) - Obsolete Product(s)

## 1 Description

The M27W512 is a low-voltage, 512 Kbit OTP (one-time programmable) EPROM. It is ideally suited to microprocessor systems and are organized as 65536 by 8 bits.

The M27W512 operates in the read mode with a supply voltage as low as 2.7 V at  $-40$  to  $85$  °C temperature range. The decrease in operating power allows either a reduction of the size of the battery or an increase in the time between battery recharges.

For applications where the content is programmed only one time and erasure is not required, the M27W512 is offered in PLCC32 packages.

**Figure 1. Logic diagram**

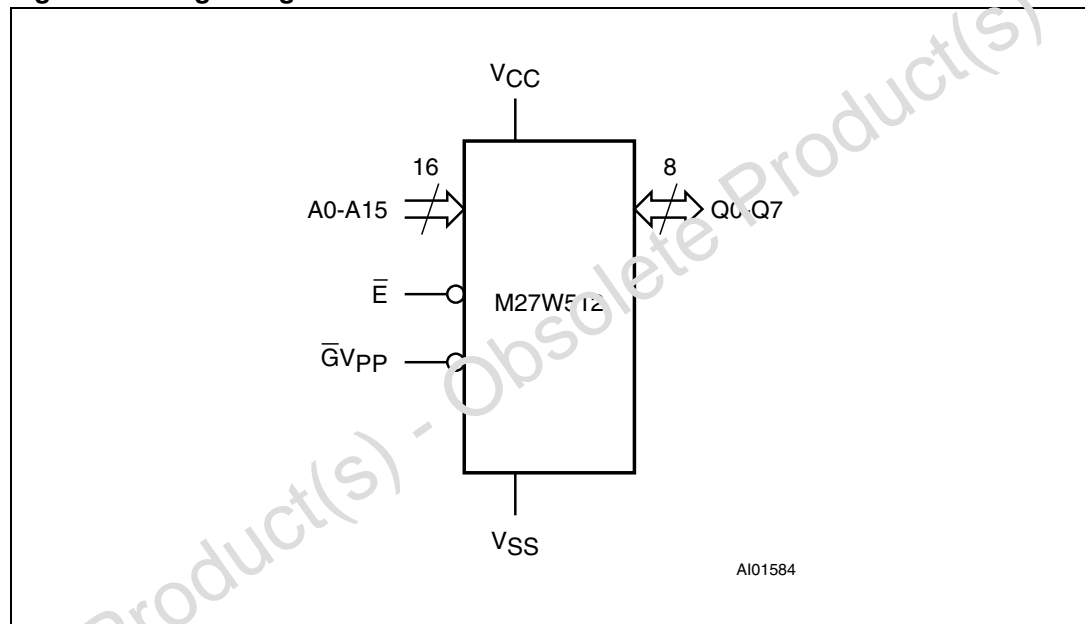

**Table 1. Signal names**

Signal names	Function
A0-A15	Address inputs
Q0-Q7	Data outputs
$\bar{E}$	Chip Enable
$\bar{G}V_{PP}$	Output Enable / Program supply
$V_{CC}$	Supply voltage
$V_{SS}$	Ground
NC	Not connected internally
DU	Don't use

**Figure 2. LCC connections**

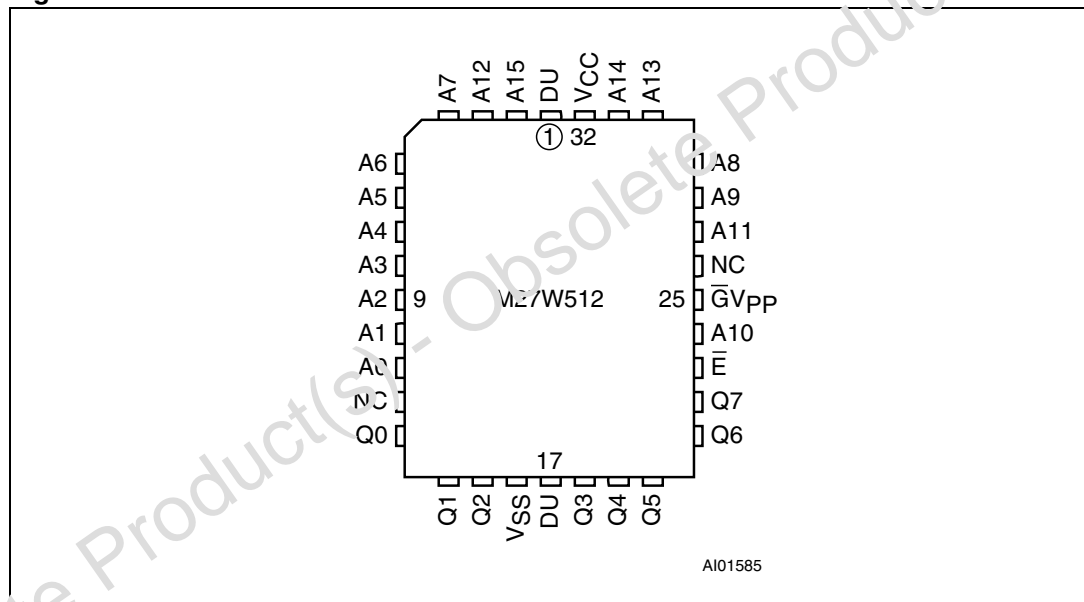

## 2 Device operation

The modes of operations of the M27W512 are listed in [Table 2: Operating modes](#). A single power supply is required in the read mode. All inputs are TTL levels except for  $\overline{G}V_{PP}$  and 12V on A9 for Electronic Signature.

### 2.1 Read mode

The M27W512 has two control functions, both of which must be logically active in order to obtain data at the outputs. Chip Enable ( $\overline{E}$ ) is the power control and should be used for device selection. Output Enable ( $\overline{G}$ ) is the output control and should be used to gate data to the output pins, independent of device selection. Assuming that the addresses are stable, the address access time ( $t_{AVQV}$ ) is equal to the delay from  $\overline{E}$  to output ( $t_{ELQV}$ ). Data is available at the output after a delay of  $t_{GLQV}$  from the falling edge of  $\overline{G}$ , assuming that  $\overline{E}$  has been low and the addresses have been stable for at least  $t_{AVQV} - t_{GLQV}$ .

### 2.2 Standby mode

The M27W512 has a standby mode which reduces the supply current from 15mA to 15 $\mu$ A with low voltage operation  $V_{CC} \leq 3.6V$ , see [Table 2: Read mode DC characteristics](#).

Characteristics table for details. The M27W512 is placed in the standby mode by applying a CMOS high signal to the  $\overline{E}$  input. When in the standby mode, the outputs are in a high impedance state, independent of the  $\overline{G}V_{PP}$  input.

**Table 2. Operating modes<sup>(1)</sup>**

Mode	$\overline{E}$	$\overline{G}V_{PP}$	A9	Q7-Q0
Read	$V_{IL}$	$V_{IL}$	X	Data Out
Output Disable	$V_{IL}$	$V_{IH}$	X	Hi-Z
Program	$V_{IL}$ Pulse	$V_{PP}$	X	Data In
Program Inhibit	$V_{IH}$	$V_{PP}$	X	Hi-Z
Standby	$V_{IH}$	X	X	Hi-Z
Electronic Signature	$V_{IL}$	$V_{IL}$	$V_{ID}$	Codes

1. X =  $V_{IH}$  or  $V_{IL}$ ,  $V_{ID} = 12V \pm 0.5V$ .

**Table 3. Electronic signature**

Identifier	A0	Q7	Q6	Q5	Q4	Q3	Q2	Q1	Q0	Hex data
Manufacturer code	$V_{IL}$	0	0	1	0	0	0	0	0	20h
Device code	$V_{IH}$	0	0	1	1	1	1	0	1	3Dh

## 2.3 Two line output control

Because EPROMs are usually used in larger memory arrays, the product features a 2 line control function which accommodates the use of multiple memory connection. The two line control function allows:

- The lowest possible memory power dissipation
- Complete assurance that output bus contention will not occur.

For the most efficient use of these two control lines,  $\bar{E}$  should be decoded and used as the primary device selecting function, while  $\bar{G}$  should be made a common connection to all devices in the array and connected to the  $\overline{\text{READ}}$  line from the system control bus. This ensures that all deselected memory devices are in their low power standby mode and that the output pins are only active when data is required from a particular memory device.

## 2.4 System considerations

The power switching characteristics of Advanced CMOS EPROMs require careful decoupling of the devices. The supply current,  $I_{CC}$ , has three segments that are of interest to the system designer: the standby current level, the active current level, and transient current peaks that are produced by the falling and rising edges of  $\bar{E}$ . The magnitude of the transient current peaks is dependent on the capacitive and inductive loading of the device at the output.

The associated transient voltage peaks can be suppressed by complying with the two line output control and by properly selected decoupling capacitors. It is recommended that a 0.1 $\mu\text{F}$  ceramic capacitor be used on every device between  $V_{CC}$  and  $V_{SS}$ . This should be a high frequency capacitor of low inherent inductance and should be placed as close to the device as possible. In addition, a 4.7 $\mu\text{F}$  bulk electrolytic capacitor should be used between  $V_{CC}$  and  $V_{SS}$  for every eight devices. The bulk capacitor should be located near the power supply connection point. The purpose of the bulk capacitor is to overcome the voltage drop caused by the inductive effects of PCB traces.

Figure 3. Programming flowchart

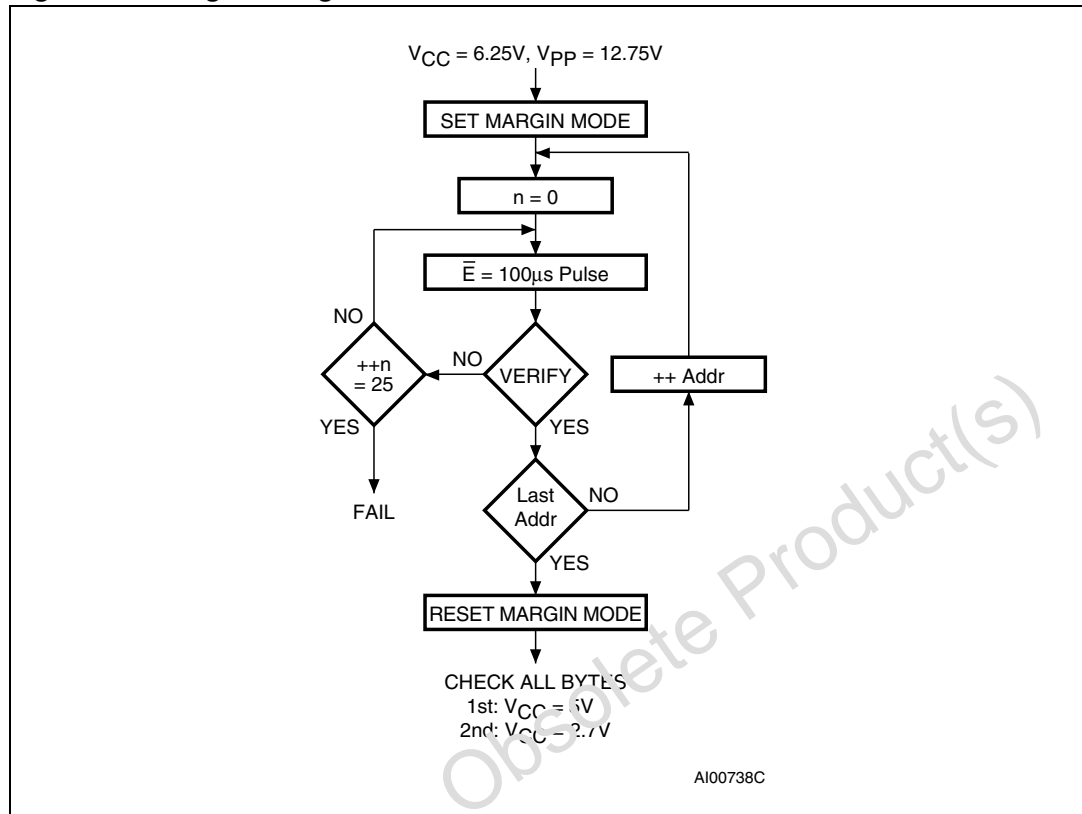

## 2.5 Programming

The M27W512 has been designed to be fully compatible with the M27C512 and has the same electronic signature. As a result, the M27W512 can be programmed as the M27C512 on the same programming equipment applying 12.75V on  $V_{PP}$  and 6.25V on  $V_{CC}$ . The M27W512 can use PRESTO IIB Programming Algorithm that drastically reduces the programming time. Nevertheless to achieve compatibility with all programming equipment, PRESTO II Programming Algorithm can be used as well. When delivered, all bits of the M27W512 are in the '1' state. Data is introduced by selectively programming '0's into the desired bit locations. Although only '0's will be programmed, both '1's and '0's can be present in the data word. The M27W512 is in the programming mode when  $V_{PP}$  input is at 12.75V and  $\bar{E}$  is pulsed to  $V_{IL}$ . The data to be programmed is applied to 8 bits in parallel to the data output pins. The levels required for the address and data inputs are TTL.  $V_{CC}$  is specified to be  $6.25V \pm 0.25V$ .

## 2.6 PRESTO IIB programming algorithm

PRESTO IIB programming algorithm allows the whole array to be programmed with a guaranteed margin, in a typical time of 6.5 seconds. This can be achieved with STMicroelectronics M27W512 due to several design innovations described in the M27W512 datasheet to improve programming efficiency and to provide adequate margin for reliability. Before starting the programming the internal MARGIN MODE circuit must be set in order to guarantee that each cell is programmed with enough margin. Then a sequence of 100µs program pulses is applied to each byte until a correct verify occurs (see [Figure 3](#)). No overprogram pulses are applied since the verify in MARGIN MODE at  $V_{CC}$  much higher than 3.6V, provides the necessary margin.

## 2.7 Program inhibit

Programming of multiple devices in parallel with different data is also easily accomplished. Except for  $\bar{E}$ , all like inputs including  $\bar{G}V_{PP}$  of the parallel M27W512 may be common. A TTL low level pulse applied to a M27W512  $\bar{E}$  input, with  $V_{PP}$  at 12.75V, will program this device. A high level  $\bar{E}$  input inhibits the other M27W512 from being programmed.

## 2.8 Program verify

A verify (read) should be performed on the programmed bits to determine that they were correctly programmed. The verify is accomplished with  $\bar{G}$  at  $V_{IL}$ . Data should be verified with  $t_{ELQV}$  after the falling edge of  $\bar{E}$ .

## 2.9 Electronic signature

The Electronic Signature (ES) mode allows the reading out of a binary code from an EPROM that will identify its manufacturer and type. This mode is intended for use by programming equipment to automatically match the device to be programmed with its corresponding programming algorithm. The ES mode is functional in the  $25^{\circ}\text{C} \pm 5^{\circ}\text{C}$  ambient temperature range that is required when programming the M27W512. To activate the ES mode, the programming equipment must force 11.5V to 12.5V on address line A9 of the M27W512. Two identifier bytes may then be sequenced from the device outputs by toggling address line A0 from  $V_{IL}$  to  $V_{IH}$ . All other address lines must be held at  $V_{IL}$  during Electronic Signature mode. Byte 0 ( $A0 = V_{IL}$ ) represents the manufacturer code and byte 1 ( $A0 = V_{IH}$ ) the device identifier code. For the STMicroelectronics M27W512, these two identifier bytes are given in [Table 3](#) and can be read-out on outputs Q7 to Q0.

Note that the M27W512 and M27C512 have the same identifier byte.

### 3 Maximum rating

Stressing the device outside the ratings listed in [Table 4](#) may cause permanent damage to the device. These are stress ratings only, and operation of the device at these, or any other conditions outside those indicated in the operating sections of this specification, is not implied. Exposure to absolute maximum rating conditions for extended periods may affect device reliability. Refer also to the STMicroelectronics SURE Program and other relevant quality documents.

**Table 4. Absolute maximum ratings**

Symbol	Parameter	Value	Unit
$T_A$	Ambient operating temperature <sup>(1)</sup>	-40 to 125	°C
$T_{BIAS}$	Temperature under bias	-50 to 125	°C
$T_{STG}$	Storage temperature	-65 to 150	°C
$V_{IO}^{(2)}$	Input or output voltage (except A9)	-2 to 7	V
$V_{CC}$	Supply voltage	-2 to 7	V
$V_{A9}^{(2)}$	A9 voltage	-2 to 13.5	V
$V_{PP}$	Program supply voltage	-2 to 14	V

1. Depends on range.
2. Minimum DC voltage on input or output is -0.5V with possible undershoot to -2.0V for a period less than 20ns. Maximum DC voltage on Output is  $V_{CC} + 0.5V$  with possible overshoot to  $V_{CC} + 2V$  for a period less than 20ns.

## 4 DC and AC parameters

This section summarizes the operating and measurement conditions, and the DC and AC characteristics of the device. The parameters in the DC and AC Characteristic tables that follow are derived from tests performed under the Measurement Conditions summarized in the relevant tables. Designers should check that the operating conditions in their circuit match the measurement conditions when relying on the quoted parameters.

**Table 5. AC measurement conditions**

	High speed	Standard
Input rise and fall times	≤10ns	≤20ns
Input pulse voltages	0 to 3V	0.4V to 2.4V
Input and output timing ref. voltages	1.5V	0.8V and 2V

**Figure 4. AC testing input output waveform**

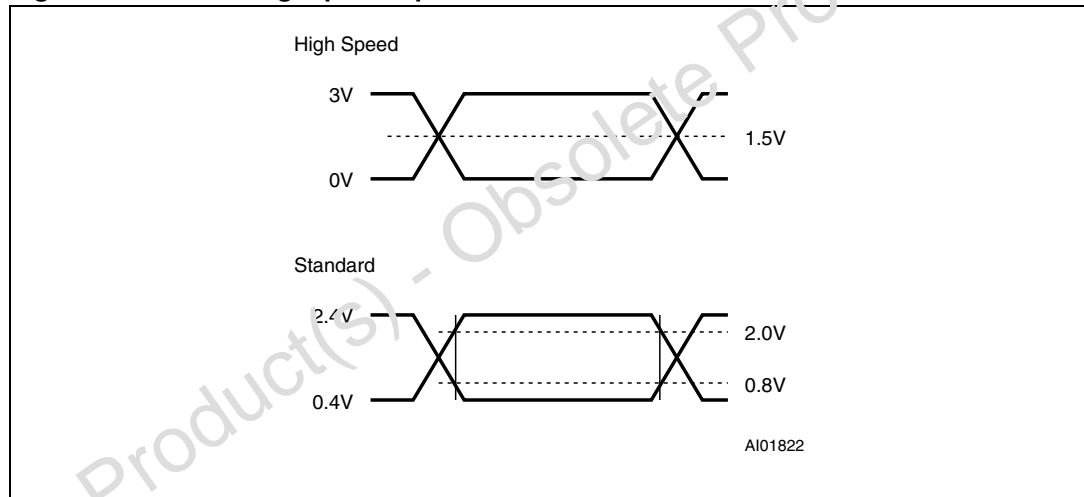

**Figure 5. AC testing load circuit**

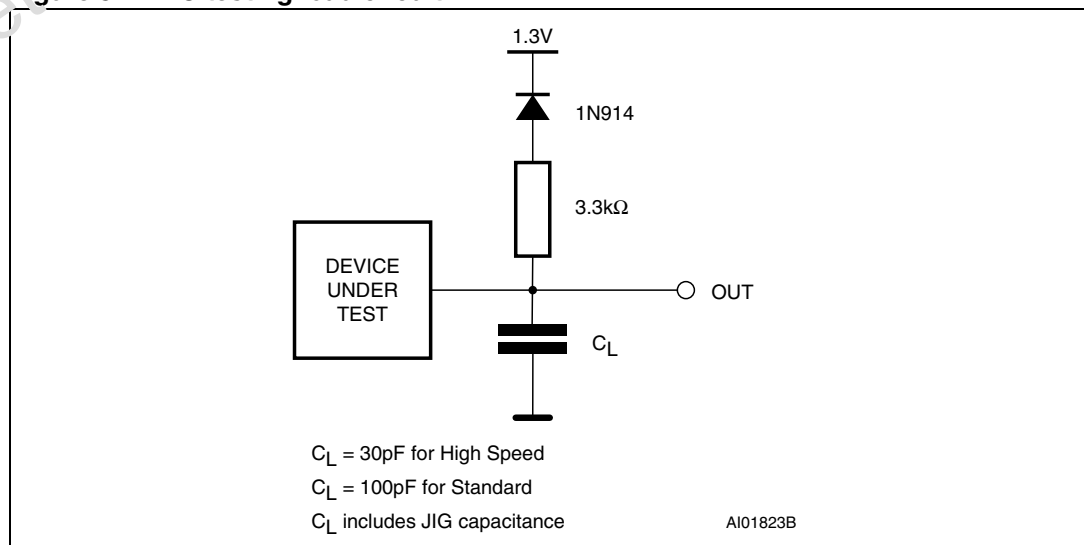

**Table 6. Capacitance**

Symbol	Parameter	Test condition <sup>(1)(2)</sup>	Min	Max	Unit
C <sub>IN</sub>	Input capacitance	V <sub>IN</sub> = 0V		6	pF
C <sub>OUT</sub>	Output capacitance	V <sub>OUT</sub> = 0V		12	pF

1. T<sub>A</sub> = 25°C, f = 1MHz
2. Sampled only, not 100% tested.

**Table 7. Read mode DC characteristics**

Symbol	Parameter	Test condition <sup>(1)</sup>	Min	Max	Unit
I <sub>LI</sub>	Input leakage current	0V ≤ V <sub>IN</sub> ≤ V <sub>CC</sub>		±10	μA
I <sub>LO</sub>	Output leakage current	0V ≤ V <sub>OUT</sub> ≤ V <sub>CC</sub>		±10	μA
I <sub>CC</sub>	Supply current	$\bar{E} = V_{IL}, \bar{G} = V_{IL},$ I <sub>OUT</sub> = 0mA, f = 5MHz V <sub>CC</sub> ≤ 3.6V		15	mA
I <sub>CC1</sub>	Supply current (Standby) TTL	$\bar{E} = V_{IH}$		1	mA
I <sub>CC2</sub>	Supply current (Standby) CMOS	$\bar{E} > V_{CC} - 0.2V,$ V <sub>CC</sub> ≤ 3.6V		15	μA
I <sub>PP</sub>	Program current	V <sub>PP</sub> = V <sub>CC</sub>		10	μA
V <sub>IL</sub>	Input low voltage		-0.6	0.2 V <sub>CC</sub>	V
V <sub>IH</sub> <sup>(2)</sup>	Input high voltage		0.7 V <sub>CC</sub>	V <sub>CC</sub> + 0.5	V
V <sub>OL</sub>	Output low voltage	I <sub>OL</sub> = 2.1mA		0.4	V
V <sub>OH</sub>	Output high voltage TTL	I <sub>OH</sub> = -1mA	2.4		V

1. V<sub>CC</sub> must be applied simultaneously with or before V<sub>PP</sub> and removed simultaneously or after V<sub>PP</sub>.
2. Maximum DC voltage on Output is V<sub>CC</sub> + 0.5V.

**Table 8. Read mode AC characteristics**

Symbol	Alt	Parameter	Test condition (1)	M27W512						Unit
				-70 <sup>(2)</sup>		-80 <sup>(2)</sup>		-100		
				V <sub>CC</sub> = 3.0 to 3.6V		V <sub>CC</sub> = 2.7 to 3.6V		V <sub>CC</sub> = 2.7 to 3.6V		
				Min	Max	Min	Max	Min	Max	
t <sub>AVQV</sub>	t <sub>ACC</sub>	Address valid to output valid	$\bar{E} = V_{IL}, \bar{G} = V_{IL}$		70		80		100	ns
t <sub>ELQV</sub>	t <sub>CE</sub>	Chip Enable low to output valid	$\bar{G} = V_{IL}$		70		80		100	ns
t <sub>GLQV</sub>	t <sub>OE</sub>	Output Enable low to output valid	$\bar{E} = V_{IL}$		40		50		60	ns
t <sub>EHQZ</sub> <sup>(3)</sup>	t <sub>DF</sub>	Chip Enable high to output Hi-Z	$\bar{G} = V_{IL}$	0	40	0	50		60	ns
t <sub>GHQZ</sub> <sup>(3)</sup>	t <sub>DF</sub>	Output Enable high to output Hi-Z	$\bar{E} = V_{IL}$	0	40	0	50		60	ns
t <sub>AXQX</sub>	t <sub>OH</sub>	Address transition to output transition	$\bar{E} = V_{IL}, \bar{G} = V_{IL}$	0		0				ns

1. V<sub>CC</sub> must be applied simultaneously with or before V<sub>PP</sub> and removed simultaneously or after V<sub>PP</sub>.
2. Speed obtained with High Speed AC measurement conditions.
3. Sampled only, not 100% tested.

**Figure 6. Read mode AC waveforms**

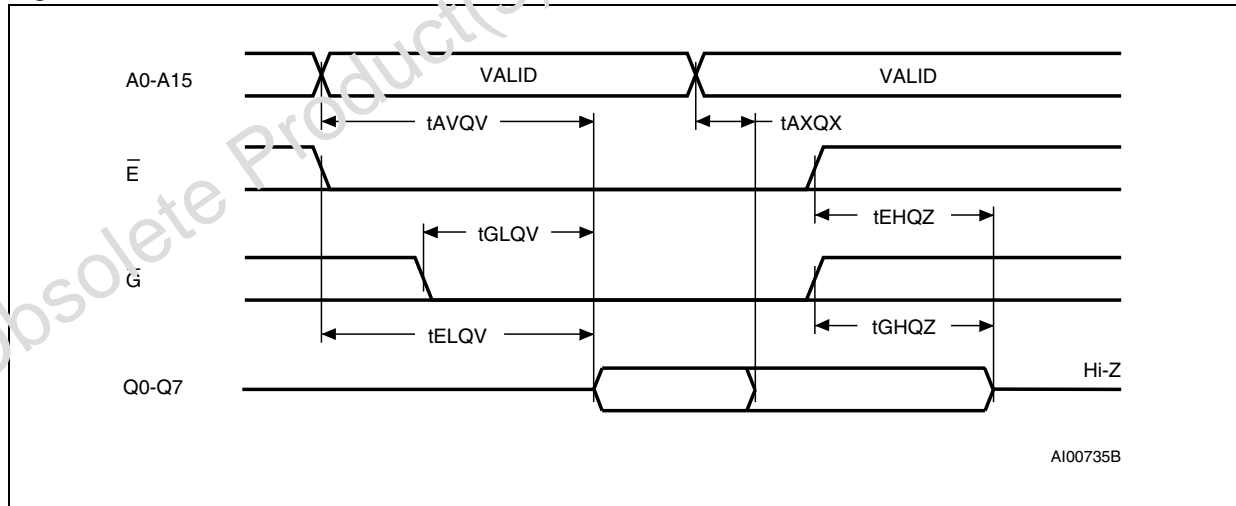

**Table 9. Programming mode DC characteristics**

Symbol	Parameter	Test condition <sup>(1)(2)</sup>	Min	Max	Unit
$I_{LI}$	Input leakage current	$V_{IL} \leq V_{IN} \leq V_{IH}$		$\pm 10$	$\mu A$
$I_{CC}$	Supply current			50	mA
$I_{PP}$	Program current	$\bar{E} = V_{IL}$		50	mA
$V_{IL}$	Input low voltage		-0.3	0.8	V
$V_{IH}$	Input high voltage		2	$V_{CC} + 0.5$	V
$V_{OL}$	Output low voltage	$I_{OL} = 2.1 mA$		0.4	V
$V_{OH}$	Output high voltage TTL	$I_{OH} = -1 mA$	3.6		V
$V_{ID}$	A9 voltage		11.5	12.5	V

1.  $T_A = 25\text{ }^\circ\text{C}$ ;  $V_{CC} = 6.25V \pm 0.25V$ ;  $V_{PP} = 12.75V \pm 0.25V$

2.  $V_{CC}$  must be applied simultaneously with or before  $V_{PP}$  and removed simultaneously or after  $V_{PP}$ .

**Table 10. Margin mode AC characteristics**

Symbol	Alt	Parameter	Test condition <sup>(1),(2)</sup>	Min	Max	Unit
$t_{A9HVPH}$	$t_{AS9}$	$V_{A9}$ high to $V_{PP}$ high		2		$\mu s$
$t_{VPHEL}$	$t_{VPS}$	$V_{PP}$ high to Chip Enable low		2		$\mu s$
$t_{A10HEH}$	$t_{AS10}$	$V_{A10}$ high to Chip Enable high (set)		1		$\mu s$
$t_{A10LEH}$	$t_{AS10}$	$V_{A10}$ low to Chip Enable high (no set)		1		$\mu s$
$t_{EXA10X}$	$t_{AH10}$	Chip Enable transition to $V_{A10}$ transition		1		$\mu s$
$t_{EXVPX}$	$t_{VPH}$	Chip Enable transition to $V_{PP}$ transition		2		$\mu s$
$t_{VPXA9X}$	$t_{AH9}$	$V_{PP}$ transition to $V_{A9}$ transition		2		$\mu s$

1.  $T_A = 25\text{ }^\circ\text{C}$ ;  $V_{CC} = 6.25V \pm 0.25V$ ;  $V_{PP} = 12.75V \pm 0.25V$

2.  $V_{CC}$  must be applied simultaneously with or before  $V_{PP}$  and removed simultaneously or after  $V_{PP}$ .

Figure 7. Margin mode AC waveforms

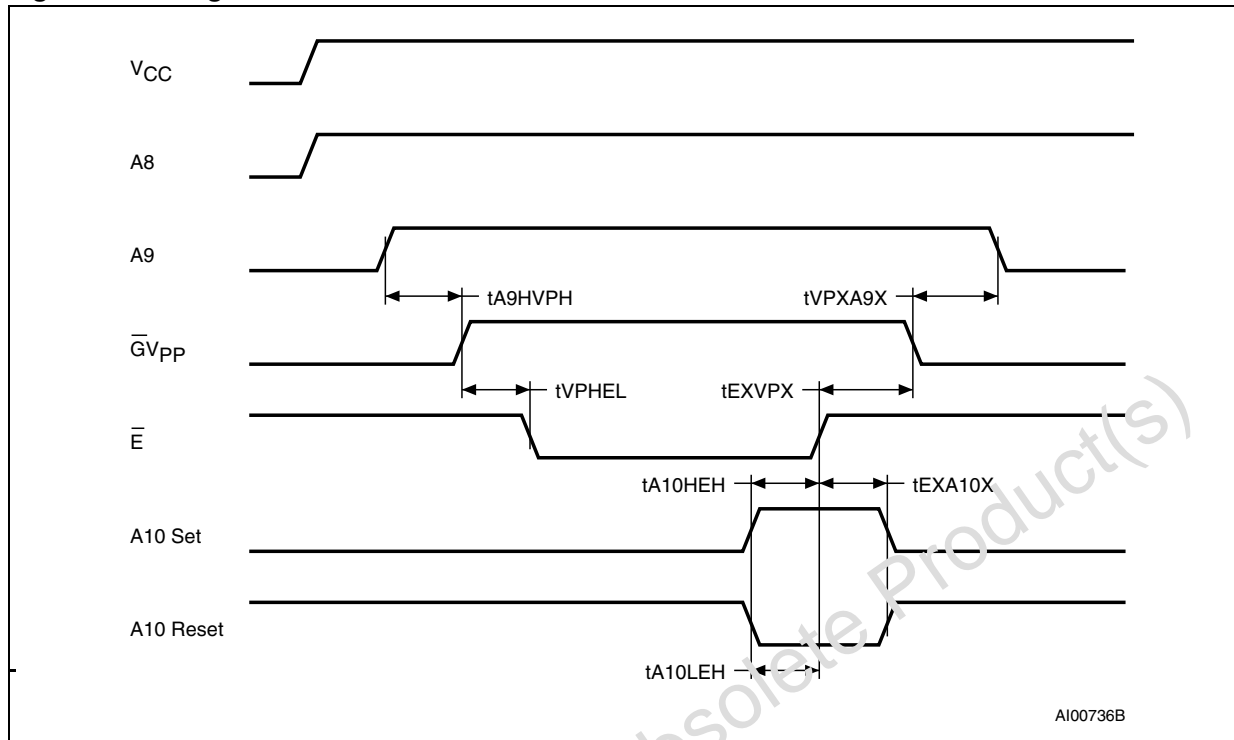

1. A8 High level = 5V; A9 High level = 12V.

Table 11. Programming mode AC characteristics

Symbol	Alt	Parameter	Test condition <sup>(1)(2)</sup>	Min	Max	Unit
t <sub>AVEL</sub>	t <sub>AS</sub>	Address valid to Chip Enable low		2		μs
t <sub>QVEL</sub>	t <sub>DS</sub>	Input Valid to Chip Enable low		2		μs
t <sub>VCHL</sub>	t <sub>VCS</sub>	V <sub>CC</sub> high to Chip Enable low		2		μs
t <sub>VPHEL</sub>	t <sub>OES</sub>	V <sub>PP</sub> high to Chip Enable low		2		μs
t <sub>VPLVPH</sub>	t <sub>PRT</sub>	V <sub>PP</sub> rise time		50		ns
t <sub>LEH</sub>	t <sub>PW</sub>	Chip Enable program pulse width (Initial)		95	105	μs
t <sub>EHQX</sub>	t <sub>DH</sub>	Chip Enable high to input transition		2		μs
t <sub>EHVPX</sub>	t <sub>OEH</sub>	Chip Enable high to V <sub>PP</sub> transition		2		μs
t <sub>VPLEL</sub>	t <sub>VR</sub>	V <sub>PP</sub> low to Chip Enable low		2		μs
t <sub>ELQV</sub>	t <sub>DV</sub>	Chip Enable low to output valid			1	μs
t <sub>EHQZ</sub> <sup>(3)</sup>	t <sub>DFP</sub>	Chip Enable high to output Hi-Z		0	130	ns
t <sub>EHAX</sub>	t <sub>AH</sub>	Chip Enable high to address transition		0		ns

1. T<sub>A</sub> = 25 °C; V<sub>CC</sub> = 6.25V ± 0.25V; V<sub>PP</sub> = 12.75V ± 0.25V

2. V<sub>CC</sub> must be applied simultaneously with or before V<sub>PP</sub> and removed simultaneously or after V<sub>PP</sub>.

3. Sampled only, not 100% tested.

Figure 8. Programming and verify mode AC waveforms

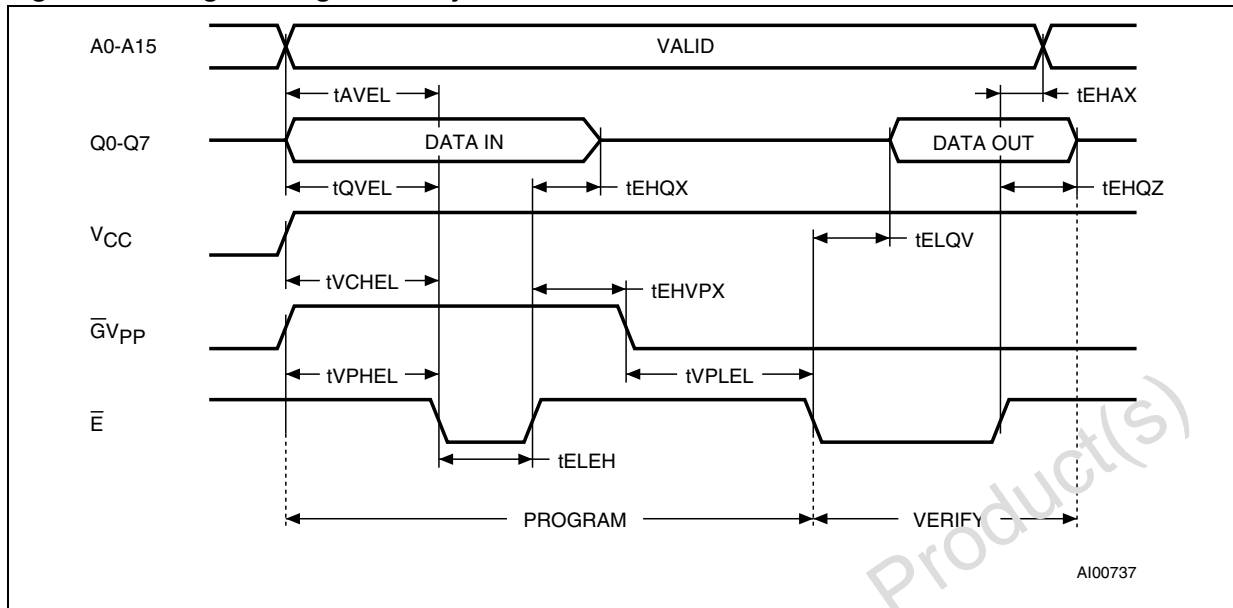

AI00737

## 5 Package mechanical data

In order to meet environmental requirements, ST offers the M27W512 in ECOPACK® packages. These packages have a lead-free second level interconnect. The category of second level interconnect is marked on the package and on the inner box label, in compliance with JEDEC Standard JESD97. The maximum ratings related to soldering conditions are also marked on the inner box label. ECOPACK is an ST trademark. ECOPACK specifications are available at [www.st.com](http://www.st.com).

Obsolete Product(s) - Obsolete Product(s)

Figure 9. PLCC32 - 32 lead plastic leaded chip carrier, package outline

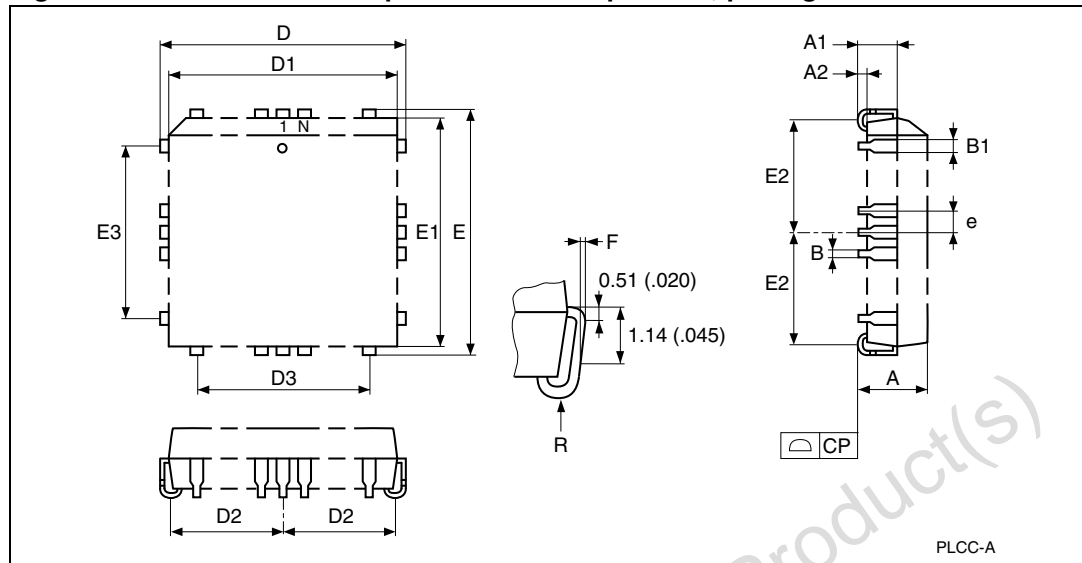

1. Drawing is not to scale.

Table 12. PLCC32 - 32 lead plastic leaded chip carrier, package mechanical data

Symbol	millimeters			inches <sup>(1)</sup>		
	Typ	Min	Max	Typ	Min	Max
A		3.175	3.556	0.1250	0.1400	
A1		1.530	2.413	0.0602	0.0950	
A2		0.381	-	0.0150	-	
B		0.330	0.533	0.0130	0.0210	
B1		0.660	0.813	0.0260	0.0320	
CP			0.100			0.0039
D		12.319	12.573	0.4850	0.4950	
D1		11.354	11.506	0.4470	0.4530	
D2		4.780	5.660	0.1882	0.2228	
D3	7.620	-	-	0.3000	-	-
E		14.859	15.113	0.5850	0.5950	
E1		13.894	14.046	0.5470	0.5530	
E2		6.050	6.930	0.2382	0.2728	
E3	10.160	-	-	0.4000	-	-
e	1.270	-	-	0.0500	-	-
F		0.000	0.127	0.0000	0.0050	
R	0.889	-	-	0.0350	-	-
N (number of pins)		32			32	

1. Values in inches are converted from mm and rounded to 4 decimal digits.

## 6 Part numbering

**Table 13. Ordering information scheme**

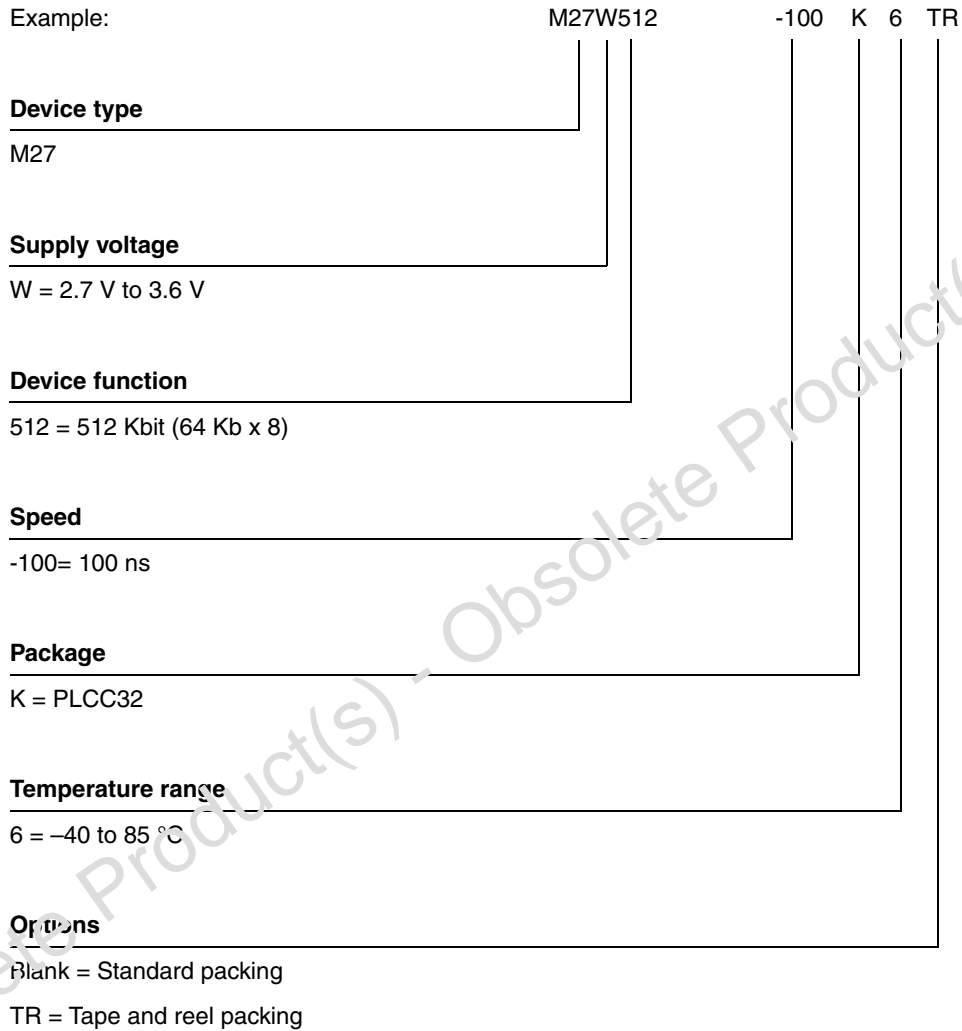

For a list of available options (speed, package, etc.) or for further information on any aspect of this device, please contact your nearest ST sales office.

## 7 Revision history

**Table 14. Document revision history**

Date	Revision	Changes
20-Mar-2000	1.1	FDIP28W Package Dimension, L Max added ( <a href="#">Table 12</a> ) TSOP32 Package Dimension changed ( <a href="#">Table 13</a> ) 0 to 70°C Temperature Range deleted Speed Classes changed
15-Jun-2001	1.2	Typing error ( <a href="#">Table 8</a> )
30-Aug-2002	1.3	Package mechanical data clarified for FDIP28W ( <a href="#">Table 12</a> ), PDIP28 ( <a href="#">Table 13</a> ), PLCC32 ( <a href="#">Table 12, Figure 9</a> ) and TSOP28 ( <a href="#">Table 13, Figure 11</a> )
08-Nov-2004	2.0	Details of ECOPACK lead-free package options added
27-Apr-2007	3	Document reformatted. FDIP28W and PDIP28 packages removed. 120, 150 and 200ns access times removed from <a href="#">Table 13: Ordering information scheme</a> .
09-Jun-2008	4	Small text changes. UV range no longer offered (references to UV removed). TSOP28 package removed. Package mechanical data in inches calculated from millimeters and rounded to three decimals (see <a href="#">Table 12: PLCC32 - 32 lead plastic leaded chip carrier, package mechanical data</a> ). E and F options and 80 ns speed class removed from <a href="#">Table 13: Ordering information scheme</a> .

**Please Read Carefully:**

Information in this document is provided solely in connection with ST products. STMicroelectronics NV and its subsidiaries ("ST") reserve the right to make changes, corrections, modifications or improvements, to this document, and the products and services described herein at any time, without notice.

All ST products are sold pursuant to ST's terms and conditions of sale.

Purchasers are solely responsible for the choice, selection and use of the ST products and services described herein, and ST assumes no liability whatsoever relating to the choice, selection or use of the ST products and services described herein.

No license, express or implied, by estoppel or otherwise, to any intellectual property rights is granted under this document. If any part of this document refers to any third party products or services it shall not be deemed a license grant by ST for the use of such third party products or services, or any intellectual property contained therein or considered as a warranty covering the use in any manner whatsoever of such third party products or services or any intellectual property contained therein.

**UNLESS OTHERWISE SET FORTH IN ST'S TERMS AND CONDITIONS OF SALE ST DISCLAIMS ANY EXPRESS OR IMPLIED WARRANTY WITH RESPECT TO THE USE AND/OR SALE OF ST PRODUCTS INCLUDING WITHOUT LIMITATION IMPLIED WARRANTIES OF MERCHANTABILITY, FITNESS FOR A PARTICULAR PURPOSE (AND THEIR EQUIVALENTS UNDER THE LAWS OF ANY JURISDICTION), OR INFRINGEMENT OF ANY PATENT, COPYRIGHT OR OTHER INTELLECTUAL PROPERTY RIGHT.**

**UNLESS EXPRESSLY APPROVED IN WRITING BY AN AUTHORIZED ST REPRESENTATIVE, ST PRODUCTS ARE NOT RECOMMENDED, AUTHORIZED OR WARRANTED FOR USE IN MILITARY, AIR CRAFT, SPACE, LIFE SAVING, OR LIFE SUSTAINING APPLICATIONS, NOR IN PRODUCTS OR SYSTEMS WHERE FAILURE OR MALFUNCTION MAY RESULT IN PERSONAL INJURY, DEATH, OR SEVERE PROPERTY OR ENVIRONMENTAL DAMAGE. ST PRODUCTS WHICH ARE NOT SPECIFIED AS "AUTOMOTIVE GRADE" MAY ONLY BE USED IN AUTOMOTIVE APPLICATIONS AT USER'S OWN RISK.**

Resale of ST products with provisions different from the statements and/or technical features set forth in this document shall immediately void any warranty granted by ST for the ST product or service described herein and shall not create or extend in any manner whatsoever, any liability of ST.

ST and the ST logo are trademarks or registered trademarks of ST in various countries.

Information in this document supersedes and replaces all information previously supplied.

The ST logo is a registered trademark of STMicroelectronics. All other names are the property of their respective owners.

© 2008 STMicroelectronics - All rights reserved



STMicroelectronics group of companies

Australia - Belgium - Brazil - Canada - China - Czech Republic - Finland - France - Germany - Hong Kong - India - Israel - Italy - Japan - Malaysia - Malta - Morocco - Singapore - Spain - Sweden - Switzerland - United Kingdom - United States of America

[www.st.com](http://www.st.com)

## Looking for pricing, stock, or lifecycle information?

Click below to explore more details on WIN SOURCE:

-  [View M27W512-100K6TR on WIN SOURCE](#)
-  [STMicroelectronics](#) Information

## Optimize Your Supply Chain with WIN SOURCE Solutions

-  Global Sourcing Solution
-  Obsolete Management
-  Cost Control Management
-  Shortage Management
-  Alternative Solution
-  Excess Inventory Management