



**THE DATASHEET OF  
M27C1001-10B1**





## M27C1001

### 1 Mbit (128Kb x8) UV EPROM and OTP EPROM

- 5V ± 10% SUPPLY VOLTAGE in READ OPERATION
- ACCESS TIME: 35ns
- LOW POWER CONSUMPTION:
  - Active Current 30mA at 5Mhz
  - Standby Current 100µA
- PROGRAMMING VOLTAGE: 12.75V ± 0.25V
- PROGRAMMING TIME: 100µs/word
- ELECTRONIC SIGNATURE
  - Manufacturer Code: 20h
  - Device Code: 05h

#### DESCRIPTION

The M27C1001 is a 1 Mbit EPROM offered in the two ranges UV (ultra violet erase) and OTP (one time programmable). It is ideally suited for micro-processor systems requiring large programs and is organized as 131,072 words of 8 bits.

The FDIP32W (window ceramic frit-seal package) and the LCCC32W (leadless chip carrier package) have a transparent lids which allow the user to expose the chip to ultraviolet light to erase the bit pattern. A new pattern can then be written to the device by following the programming procedure.

For applications where the content is programmed only one time and erasure is not required, the M27C1001 is offered in PDIP32, PLCC32 and TSOP32 (8 x 20 mm) packages.

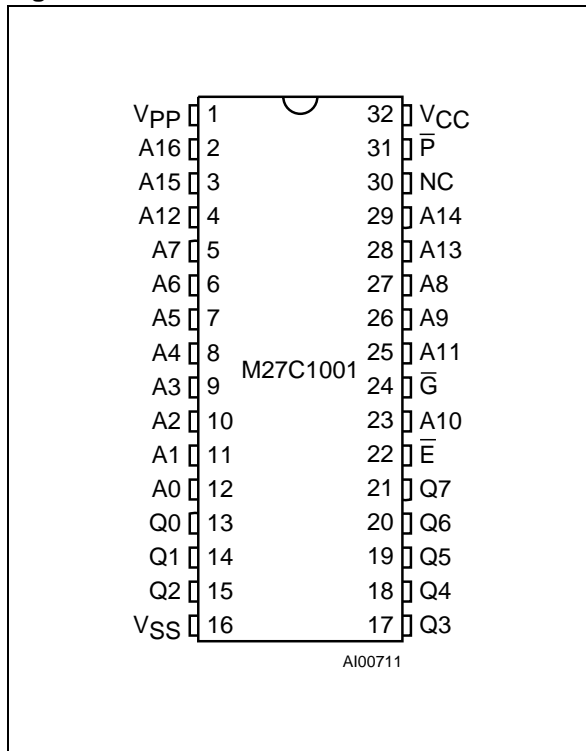

Figure 1. Logic Diagram



# M27C1001

**Figure 2A. DIP Connections**



**Figure 2B. LCC Connections**

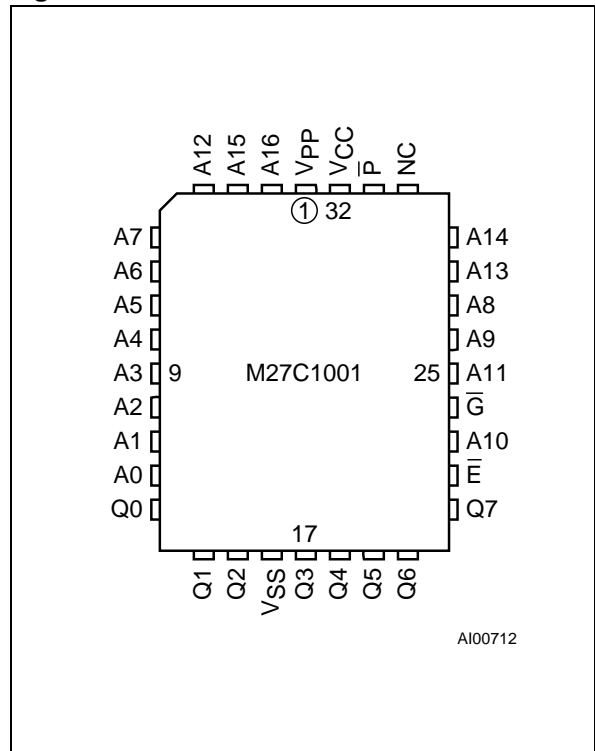

**Figure 2C. TSOP Connections**

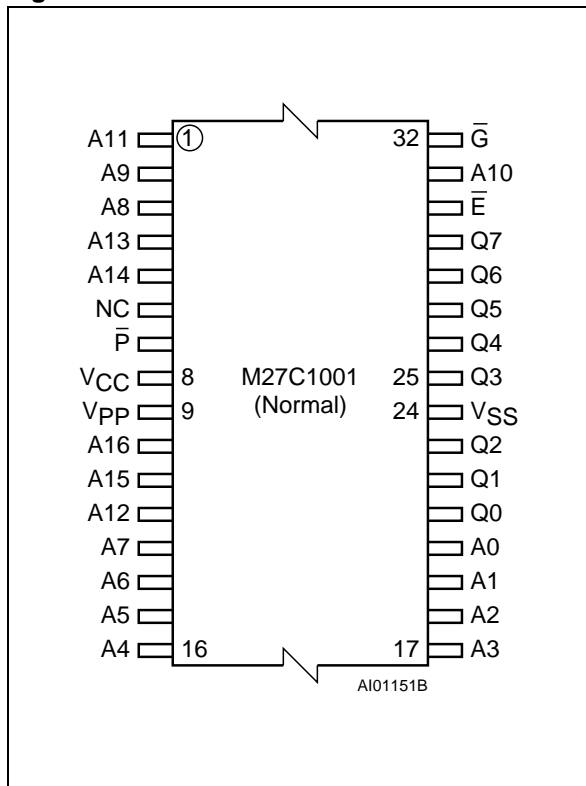

**Table 1. Signal Names**

A0-A16	Address Inputs
Q0-Q7	Data Outputs
$\bar{E}$	Chip Enable
$\bar{G}$	Output Enable
$\bar{P}$	Program
$V_{PP}$	Program Supply
$V_{CC}$	Supply Voltage
$V_{SS}$	Ground
NC	Not Connected Internally

**Table 2. Absolute Maximum Ratings (1)**

Symbol	Parameter	Value	Unit
T <sub>A</sub>	Ambient Operating Temperature (3)	-40 to 125	°C
T <sub>BIAS</sub>	Temperature Under Bias	-50 to 125	°C
T <sub>STG</sub>	Storage Temperature	-65 to 150	°C
V <sub>IO</sub> (2)	Input or Output Voltage (except A9)	-2 to 7	V
V <sub>CC</sub>	Supply Voltage	-2 to 7	V
V <sub>A9</sub> (2)	A9 Voltage	-2 to 13.5	V
V <sub>PP</sub>	Program Supply Voltage	-2 to 14	V

Note: 1. Except for the rating "Operating Temperature Range", stresses above those listed in the Table "Absolute Maximum Ratings" may cause permanent damage to the device. These are stress ratings only and operation of the device at these or any other conditions above those indicated in the Operating sections of this specification is not implied. Exposure to Absolute Maximum Rating conditions for extended periods may affect device reliability. Refer also to the STMicroelectronics SURE Program and other relevant quality documents.

2. Minimum DC voltage on Input or Output is -0.5V with possible undershoot to -2.0V for a period less than 20ns. Maximum DC voltage on Output is V<sub>CC</sub> +0.5V with possible overshoot to V<sub>CC</sub> +2V for a period less than 20ns.
3. Depends on range.

**Table 3. Operating Modes**

Mode	$\bar{E}$	$\bar{G}$	$\bar{P}$	A9	V <sub>PP</sub>	Q7-Q0
Read	V <sub>IL</sub>	V <sub>IL</sub>	X	X	V <sub>CC</sub> or V <sub>SS</sub>	Data Out
Output Disable	V <sub>IL</sub>	V <sub>IH</sub>	X	X	V <sub>CC</sub> or V <sub>SS</sub>	Hi-Z
Program	V <sub>IL</sub>	V <sub>IH</sub>	V <sub>IL</sub> Pulse	X	V <sub>PP</sub>	Data In
Verify	V <sub>IL</sub>	V <sub>IL</sub>	V <sub>IH</sub>	X	V <sub>PP</sub>	Data Out
Program Inhibit	V <sub>IH</sub>	X	X	X	V <sub>PP</sub>	Hi-Z
Standby	V <sub>IH</sub>	X	X	X	V <sub>CC</sub> or V <sub>SS</sub>	Hi-Z
Electronic Signature	V <sub>IL</sub>	V <sub>IL</sub>	V <sub>IH</sub>	V <sub>ID</sub>	V <sub>CC</sub>	Codes

Note: X = V<sub>IH</sub> or V<sub>IL</sub>, V<sub>ID</sub> = 12V ± 0.5V.

**Table 4. Electronic Signature**

Identifier	A0	Q7	Q6	Q5	Q4	Q3	Q2	Q1	Q0	Hex Data
Manufacturer's Code	V <sub>IL</sub>	0	0	1	0	0	0	0	0	20h
Device Code	V <sub>IH</sub>	0	0	0	0	0	1	0	1	05h

**Table 5. AC Measurement Conditions**

	High Speed	Standard
Input Rise and Fall Times	≤ 10ns	≤ 20ns
Input Pulse Voltages	0 to 3V	0.4V to 2.4V
Input and Output Timing Ref. Voltages	1.5V	0.8V and 2V

**Figure 3. AC Testing Input Output Waveform**



**Figure 4. AC Testing Load Circuit**



**Table 6. Capacitance <sup>(1)</sup> (T<sub>A</sub> = 25 °C, f = 1 MHz)**

Symbol	Parameter	Test Condition	Min	Max	Unit
C <sub>IN</sub>	Input Capacitance	V <sub>IN</sub> = 0V		6	pF
C <sub>OUT</sub>	Output Capacitance	V <sub>OUT</sub> = 0V		12	pF

Note: 1. Sampled only, not 100% tested.

**DEVICE OPERATION**

The operating modes of the M27C1001 are listed in the Operating Modes table. A single power supply is required in the read mode. All inputs are TTL levels except for V<sub>PP</sub> and 12V on A9 for Electronic Signature.

**Read Mode**

The M27C1001 has two control functions, both of which must be logically active in order to obtain data at the outputs. Chip Enable ( $\bar{E}$ ) is the power control and should be used for device selection. Output Enable ( $\bar{G}$ ) is the output control and should be used to gate data to the output pins, independent

of device selection. Assuming that the addresses are stable, the address access time (t<sub>AVQV</sub>) is equal to the delay from  $\bar{E}$  to output (t<sub>ELQV</sub>). Data is available at the output after a delay of t<sub>GLQV</sub> from the falling edge of  $\bar{G}$ , assuming that  $\bar{E}$  has been low and the addresses have been stable for at least t<sub>AVQV</sub>-t<sub>GLQV</sub>.

**Standby Mode**

The M27C1001 has a standby mode which reduces the supply current from 30mA to 100μA. The M27C1001 is placed in the standby mode by applying a CMOS high signal to the  $\bar{E}$  input. When in the standby mode, the outputs are in a high impedance state, independent of the  $\bar{G}$  input.

**Table 7. Read Mode DC Characteristics (1)**

(TA = 0 to 70°C, -40 to 85°C or -40 to 125°C; VCC = 5V ± 5% or 5V ± 10%; VPP = VCC)

Symbol	Parameter	Test Condition	Min	Max	Unit
ILI	Input Leakage Current	$0V \leq V_{IN} \leq V_{CC}$		±10	μA
ILO	Output Leakage Current	$0V \leq V_{OUT} \leq V_{CC}$		±10	μA
ICC	Supply Current	$\bar{E} = V_{IL}, \bar{G} = V_{IL}, I_{OUT} = 0mA, f = 5MHz$		30	mA
ICC1	Supply Current (Standby) TTL	$\bar{E} = V_{IH}$		1	mA
ICC2	Supply Current (Standby) CMOS	$\bar{E} > V_{CC} - 0.2V$		100	μA
I <sub>PP</sub>	Program Current	$V_{PP} = V_{CC}$		10	μA
V <sub>IL</sub>	Input Low Voltage		-0.3	0.8	V
V <sub>IH</sub> (2)	Input High Voltage		2	V <sub>CC</sub> + 1	V
V <sub>OL</sub>	Output Low Voltage	$I_{OL} = 2.1mA$		0.4	V
V <sub>OH</sub>	Output High Voltage TTL	$I_{OH} = -400\mu A$	2.4		V
	Output High Voltage CMOS	$I_{OH} = -100\mu A$	V <sub>CC</sub> - 0.7V		V

Note: 1. VCC must be applied simultaneously with or before VPP and removed simultaneously or after VPP.

2. Maximum DC voltage on Output is VCC + 0.5V.

**Table 8A. Read Mode AC Characteristics (1)**

(TA = 0 to 70°C, -40 to 85°C or -40 to 125°C; VCC = 5V ± 5% or 5V ± 10%; VPP = VCC)

Symbol	Alt	Parameter	Test Condition	M27C1001								Unit
				-35 (3)		-45		-60		-70		
				Min	Max	Min	Max	Min	Max	Min	Max	
t <sub>AVQV</sub>	t <sub>ACC</sub>	Address Valid to Output Valid	$\bar{E} = V_{IL}, \bar{G} = V_{IL}$		35		45		60		70	ns
t <sub>ELQV</sub>	t <sub>CE</sub>	Chip Enable Low to Output Valid	$\bar{G} = V_{IL}$		35		45		60		70	ns
t <sub>GLQV</sub>	t <sub>OE</sub>	Output Enable Low to Output Valid	$\bar{E} = V_{IL}$		25		25		30		35	ns
t <sub>EHQZ</sub> (2)	t <sub>DF</sub>	Chip Enable High to Output Hi-Z	$\bar{G} = V_{IL}$	0	25	0	25	0	30	0	30	ns
t <sub>GHQZ</sub> (2)	t <sub>DF</sub>	Output Enable High to Output Hi-Z	$\bar{E} = V_{IL}$	0	25	0	25	0	30	0	30	ns
t <sub>AXQX</sub>	t <sub>OH</sub>	Address Transition to Output Transition	$\bar{E} = V_{IL}, \bar{G} = V_{IL}$	0		0		0		0		ns

Note: 1. VCC must be applied simultaneously with or before VPP and removed simultaneously or after VPP.

2. Sampled only, not 100% tested.

3. Speed obtained with High Speed AC measurement conditions.

### Two Line Output Control

Because EPROMs are usually used in larger memory arrays, this product features a 2 line control function which accommodates the use of multiple memory connection. The two line control function allows:

- the lowest possible memory power dissipation,
- complete assurance that output bus contention will not occur.

For the most efficient use of these two control lines,  $\bar{E}$  should be decoded and used as the primary device selecting function, while  $\bar{G}$  should be made a common connection to all devices in the array and connected to the READ line from the system control bus. This ensures that all deselected memory devices are in their low power standby mode and that the output pins are only active when data is required from a particular memory device.

## M27C1001

**Table 8B. Read Mode AC Characteristics (1)**

( $T_A = 0$  to  $70^\circ\text{C}$ ,  $-40$  to  $85^\circ\text{C}$  or  $-40$  to  $125^\circ\text{C}$ ;  $V_{CC} = 5\text{V} \pm 5\%$  or  $5\text{V} \pm 10\%$ ;  $V_{PP} = V_{CC}$ )

Symbol	Alt	Parameter	Test Condition	M27C1001								Unit
				-80		-90		-10		-12/-15/ -20/-25		
				Min	Max	Min	Max	Min	Max	Min	Max	
$t_{AVQV}$	$t_{ACC}$	Address Valid to Output Valid	$\bar{E} = V_{IL}, \bar{G} = V_{IL}$		80		90		100		120	ns
$t_{ELQV}$	$t_{CE}$	Chip Enable Low to Output Valid	$\bar{G} = V_{IL}$		80		90		100		120	ns
$t_{GLQV}$	$t_{OE}$	Output Enable Low to Output Valid	$\bar{E} = V_{IL}$		40		45		50		60	ns
$t_{EHQZ}^{(2)}$	$t_{DF}$	Chip Enable High to Output Hi-Z	$\bar{G} = V_{IL}$	0	30	0	30	0	30	0	40	ns
$t_{GHQZ}^{(2)}$	$t_{DF}$	Output Enable High to Output Hi-Z	$\bar{E} = V_{IL}$	0	30	0	30	0	30	0	40	ns
$t_{AXQX}$	$t_{OH}$	Address Transition to Output Transition	$\bar{E} = V_{IL}, \bar{G} = V_{IL}$	0		0		0		0		ns

Note: 1.  $V_{CC}$  must be applied simultaneously with or before  $V_{PP}$  and removed simultaneously or after  $V_{PP}$ .  
2. Sampled only, not 100% tested.

**Figure 5. Read Mode AC Waveforms**



### System Considerations

The power switching characteristics of Advanced CMOS EPROMs require careful decoupling of the devices. The supply current,  $I_{CC}$ , has three segments that are of interest to the system designer: the standby current level, the active current level, and transient current peaks that are produced by the falling and rising edges of  $\bar{E}$ . The magnitude of the transient current peaks is dependent on the capacitive and inductive loading of the device at the output. The associated transient voltage peaks can be suppressed by complying with the two line

output control and by properly selected decoupling capacitors. It is recommended that a  $0.1\mu\text{F}$  ceramic capacitor be used on every device between  $V_{CC}$  and  $V_{SS}$ . This should be a high frequency capacitor of low inherent inductance and should be placed as close to the device as possible. In addition, a  $4.7\mu\text{F}$  bulk electrolytic capacitor should be used between  $V_{CC}$  and  $V_{SS}$  for every eight devices. The bulk capacitor should be located near the power supply connection point. The purpose of the bulk capacitor is to overcome the voltage drop caused by the inductive effects of PCB traces.

**Table 9. Programming Mode DC Characteristics (1)**(T<sub>A</sub> = 25 °C; V<sub>CC</sub> = 6.25V ± 0.25V; V<sub>PP</sub> = 12.75V ± 0.25V)

Symbol	Parameter	Test Condition	Min	Max	Unit
I <sub>LI</sub>	Input Leakage Current	V <sub>IL</sub> ≤ V <sub>IN</sub> ≤ V <sub>IH</sub>		±10	μA
I <sub>CC</sub>	Supply Current			50	mA
I <sub>PP</sub>	Program Current	$\bar{E} = V_{IL}$		50	mA
V <sub>IL</sub>	Input Low Voltage		-0.3	0.8	V
V <sub>IH</sub>	Input High Voltage		2	V <sub>CC</sub> + 0.5	V
V <sub>OL</sub>	Output Low Voltage	I <sub>OL</sub> = 2.1mA		0.4	V
V <sub>OH</sub>	Output High Voltage TTL	I <sub>OH</sub> = -400μA	2.4		V
V <sub>ID</sub>	A9 Voltage		11.5	12.5	V

Note: 1. V<sub>CC</sub> must be applied simultaneously with or before V<sub>PP</sub> and removed simultaneously or after V<sub>PP</sub>.**Table 10. Programming Mode AC Characteristics (1)**(T<sub>A</sub> = 25 °C; V<sub>CC</sub> = 6.25V ± 0.25V; V<sub>PP</sub> = 12.75V ± 0.25V)

Symbol	Alt	Parameter	Test Condition	Min	Max	Unit
t <sub>AVPL</sub>	t <sub>AS</sub>	Address Valid to Program Low		2		μs
t <sub>QVPL</sub>	t <sub>DS</sub>	Input Valid to Program Low		2		μs
t <sub>VPHPL</sub>	t <sub>VPS</sub>	V <sub>PP</sub> High to Program Low		2		μs
t <sub>VCHPL</sub>	t <sub>VCS</sub>	V <sub>CC</sub> High to Program Low		2		μs
t <sub>ELPL</sub>	t <sub>CES</sub>	Chip Enable Low to Program Low		2		μs
t <sub>PLPH</sub>	t <sub>PW</sub>	Program Pulse Width		95	105	μs
t <sub>PHQX</sub>	t <sub>DH</sub>	Program High to Input Transition		2		μs
t <sub>QXGL</sub>	t <sub>OES</sub>	Input Transition to Output Enable Low		2		μs
t <sub>GLQV</sub>	t <sub>OE</sub>	Output Enable Low to Output Valid			100	ns
t <sub>GHQZ</sub> (2)	t <sub>DFP</sub>	Output Enable High to Output Hi-Z		0	130	ns
t <sub>GHAX</sub>	t <sub>AH</sub>	Output Enable High to Address Transition		0		ns

Note: 1. V<sub>CC</sub> must be applied simultaneously with or before V<sub>PP</sub> and removed simultaneously or after V<sub>PP</sub>.

2. Sampled only, not 100% tested.

## Programming

When delivered (and after each erasure for UV EPROM), all bits of the M27C1001 are in the '1' state. Data is introduced by selectively programming '0's into the desired bit locations. Although only '0's will be programmed, both '1's and '0's can be present in the data word. The only way to change a '0' to a '1' is by die exposition to ultraviolet

light (UV EPROM). The M27C1001 is in the programming mode when V<sub>PP</sub> input is at 12.75V,  $\bar{E}$  is at V<sub>IL</sub> and  $\bar{P}$  is pulsed to V<sub>IL</sub>. The data to be programmed is applied to 8 bits in parallel to the data output pins. The levels required for the address and data inputs are TTL. V<sub>CC</sub> is specified to be 6.25V ± 0.25V.

Figure 6. Programming and Verify Modes AC Waveforms

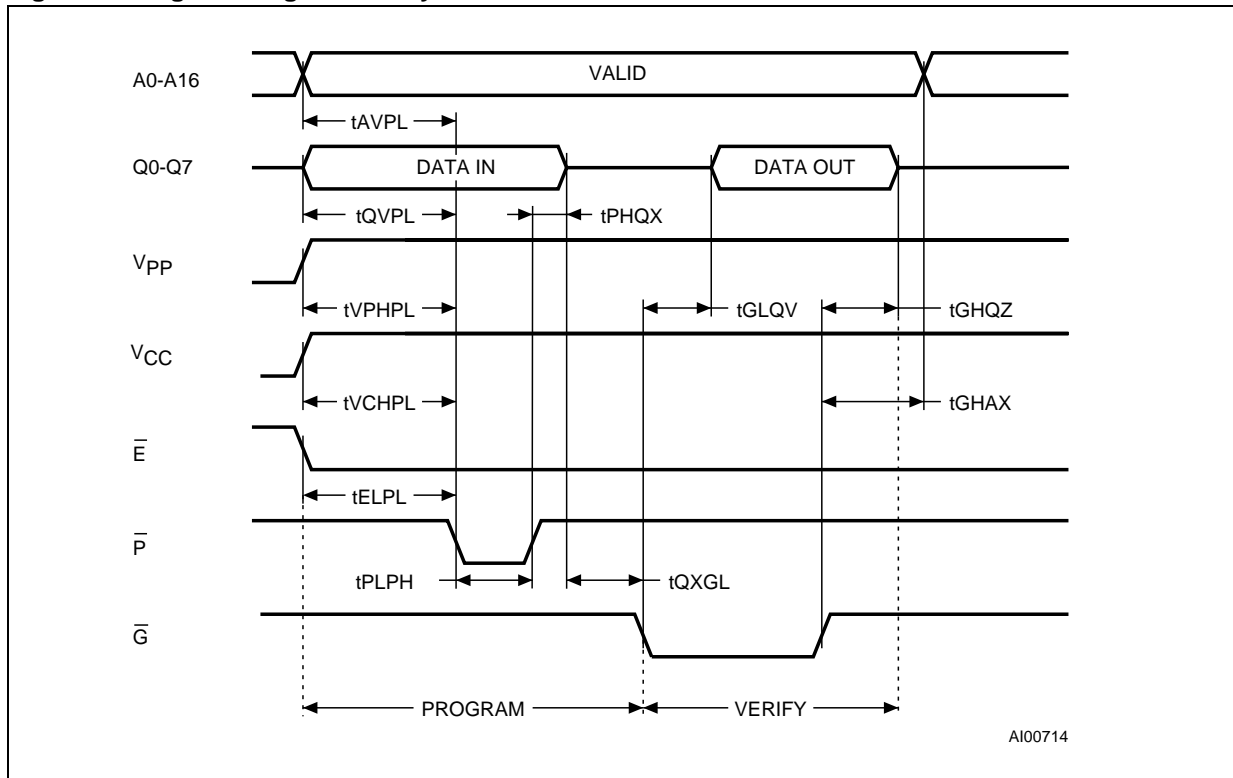
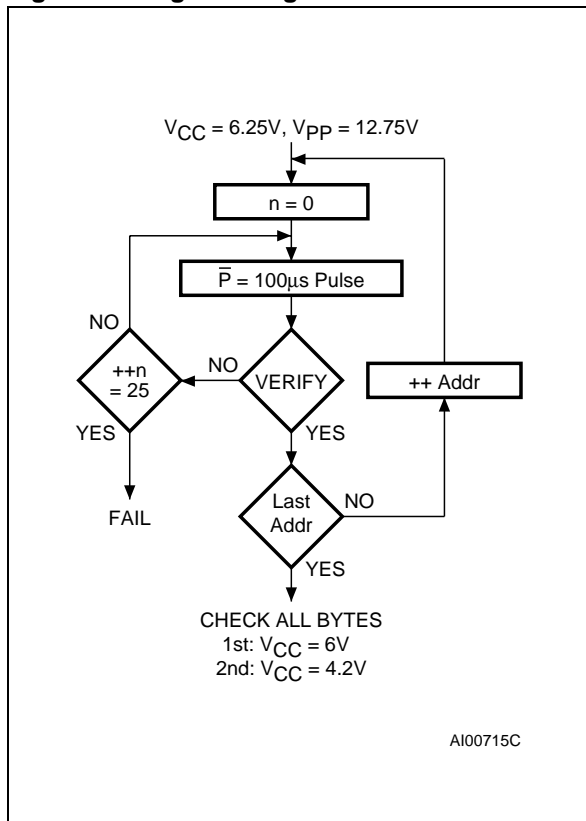

Figure 7. Programming Flowchart



**PRESTO II Programming Algorithm**

PRESTO II Programming Algorithm allows the whole array to be programmed, with a guaranteed margin, in a typical time of 13 seconds. Programming with PRESTO II involves in applying a sequence of 100μs program pulses to each byte until a correct verify occurs (see Figure 7). During programming and verify operation, a MARGIN MODE circuit is automatically activated in order to guarantee that each cell is programmed with enough margin. No overprogram pulse is applied since the verify in MARGIN MODE provides necessary margin to each programmed cell.

**Program Inhibit**

Programming of multiple M27C1001s in parallel with different data is also easily accomplished. Except for E<sub>bar</sub>, all like inputs including G<sub>bar</sub> of the parallel M27C1001 may be common. A TTL low level pulse applied to a M27C1001's P<sub>bar</sub> input, with E<sub>bar</sub> low and V<sub>PP</sub> at 12.75V, will program that M27C1001. A high level E<sub>bar</sub> input inhibits the other M27C1001s from being programmed.

**Program Verify**

A verify (read) should be performed on the programmed bits to determine that they were correctly programmed. The verify is accomplished with E<sub>bar</sub> and G<sub>bar</sub> at V<sub>IL</sub>, P<sub>bar</sub> at V<sub>IH</sub>, V<sub>PP</sub> at 12.75V and V<sub>CC</sub> at 6.25V.

### Electronic Signature

The Electronic Signature (ES) mode allows the reading out of a binary code from an EPROM that will identify its manufacturer and type. This mode is intended for use by programming equipment to automatically match the device to be programmed with its corresponding programming algorithm. The ES mode is functional in the  $25^{\circ}\text{C} \pm 5^{\circ}\text{C}$  ambient temperature range that is required when programming the M27C1001. To activate the ES mode, the programming equipment must force 11.5V to 12.5V on address line A9 of the M27C1001, with  $V_{PP} = V_{CC} = 5\text{V}$ . Two identifier bytes may then be sequenced from the device outputs by toggling address line A0 from  $V_{IL}$  to  $V_{IH}$ . All other address lines must be held at  $V_{IL}$  during Electronic Signature mode.

Byte 0 ( $A0 = V_{IL}$ ) represents the manufacturer code and byte 1 ( $A0 = V_{IH}$ ) the device identifier code. For the STMicroelectronics M27C1001, these two identifier bytes are given in Table 4 and can be read-out on outputs Q7 to Q0.

### ERASURE OPERATION (applies to UV EPROM)

The erasure characteristics of the M27C1001 is such that erasure begins when the cells are exposed to light with wavelengths shorter than approximately 4000 Å. It should be noted that sunlight and some type of fluorescent lamps have wavelengths in the 3000-4000 Å range. Research shows that constant exposure to room level fluorescent lighting could erase a typical M27C1001 in about 3 years, while it would take approximately 1 week to cause erasure when exposed to direct sunlight. If the M27C1001 is to be exposed to these types of lighting conditions for extended periods of time, it is suggested that opaque labels be put over the M27C1001 window to prevent unintentional erasure. The recommended erasure procedure for the M27C1001 is exposure to short wave ultraviolet light which has a wavelength of 2537 Å. The integrated dose (i.e. UV intensity x exposure time) for erasure should be a minimum of  $15 \text{ W-sec/cm}^2$ . The erasure time with this dosage is approximately 15 to 20 minutes using an ultraviolet lamp with  $12000 \mu\text{W/cm}^2$  power rating. The M27C1001 should be placed within 2.5 cm (1 inch) of the lamp tubes during the erasure. Some lamps have a filter on their tubes which should be removed before erasure.

# M27C1001

**Table 11. Ordering Information Scheme**

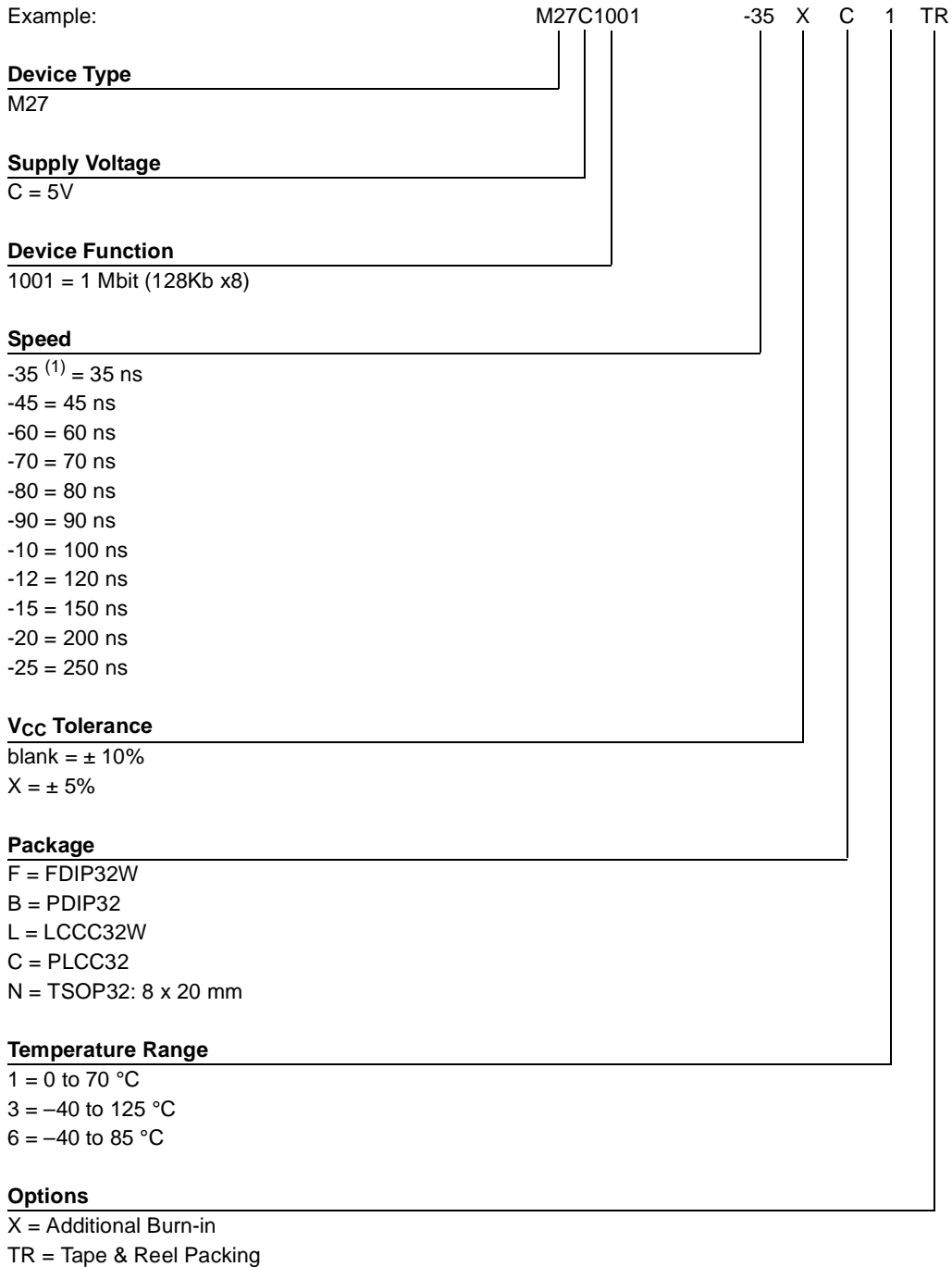

Note: 1. High Speed, see AC Characteristics section for further information.

For a list of available options (Speed, Package, etc...) or for further information on any aspect of this device, please contact the STMicroelectronics Sales Office nearest to you.



**Table 12. Revision History**

Date	Revision Details
September 1998	First Issue
24-Jan-2000	35ns speed class added (Table 8A, 11)
20-Sep-2000	AN620 Reference removed
04-Jun-2002	PLCC32 Package mechanical data and drawing clarified (Table 16 and Figure 11) TSOP32 Package mechanical data clarified (Table 17)

Table 13. FDIP32W - 32 pin Ceramic Frit-seal DIP with window, Package Mechanical Data

Symbol	millimeters			inches		
	Typ	Min	Max	Typ	Min	Max
A			5.72			0.225
A1		0.51	1.40		0.020	0.055
A2		3.91	4.57		0.154	0.180
A3		3.89	4.50		0.153	0.177
B		0.41	0.56		0.016	0.022
B1	1.45	–	–	0.057	–	–
C		0.23	0.30		0.009	0.012
D		41.73	42.04		1.643	1.655
D2	38.10	–	–	1.500	–	–
E	15.24	–	–	0.600	–	–
E1		13.06	13.36		0.514	0.526
e	2.54	–	–	0.100	–	–
eA	14.99	–	–	0.590	–	–
eB		16.18	18.03		0.637	0.710
L		3.18			0.125	
S		1.52	2.49		0.060	0.098
∅	7.11	–	–	0.280	–	–
α		4°	11°		4°	11°
N		32			32	

Figure 8. FDIP32W - 32 pin Ceramic Frit-seal DIP with window, Package Outline

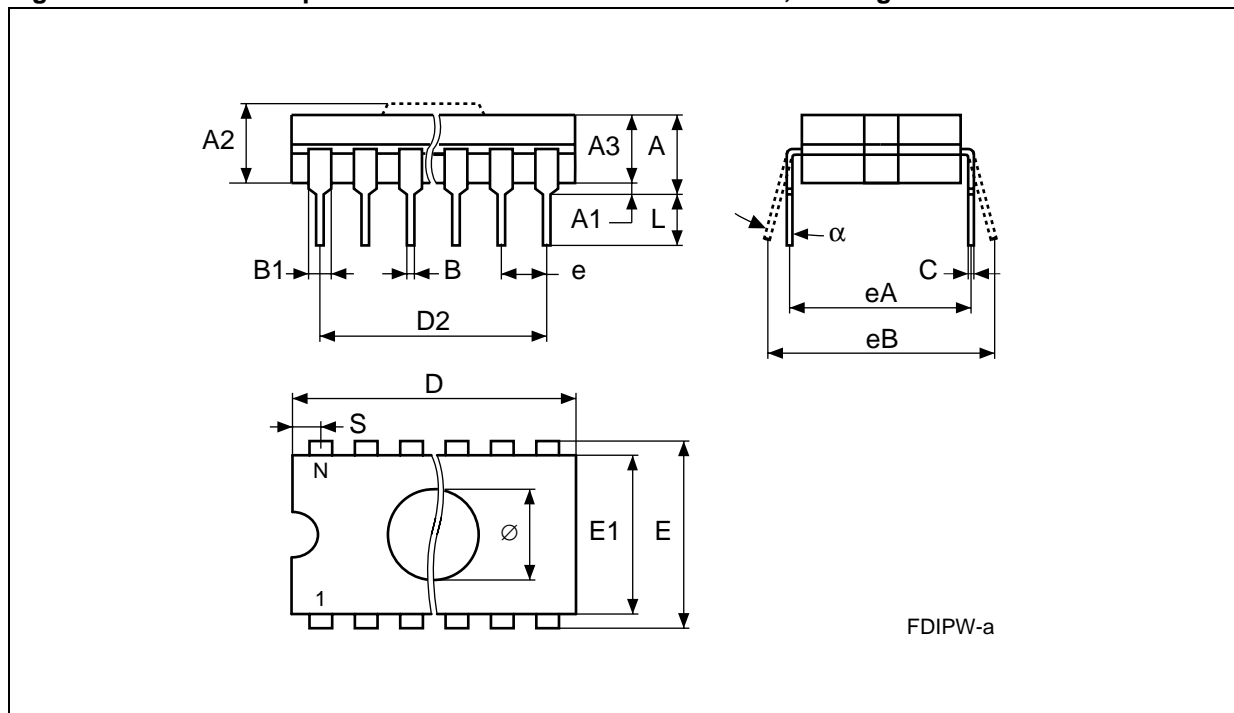

Drawing is not to scale.

Table 14. PDIP32 - 32 lead Plastic DIP, 600 mils width, Package Mechanical Data

Symbol	millimeters			inches		
	Typ	Min	Max	Typ	Min	Max
A		–	5.08		–	0.200
A1		0.38	–		0.015	–
A2		3.56	4.06		0.140	0.160
B		0.38	0.51		0.015	0.020
B1	1.52	–	–	0.060	–	–
C		0.20	0.30		0.008	0.012
D		41.78	42.04		1.645	1.655
D2	38.10	–	–	1.500	–	–
E	15.24	–	–	0.600	–	–
E1		13.59	13.84		0.535	0.545
e1	2.54	–	–	0.100	–	–
eA	15.24	–	–	0.600	–	–
eB		15.24	17.78		0.600	0.700
L		3.18	3.43		0.125	0.135
S		1.78	2.03		0.070	0.080
$\alpha$		0°	10°		0°	10°
N	32			32		

Figure 9. PDIP32 - 32 lead Plastic DIP, 600 mils width, Package Outline



Drawing is not to scale.

Table 15. LCCC32W - 32 lead Leadless Ceramic Chip Carrier, Package Mechanical Data

Symbol	millimeters			inches		
	Typ	Min	Max	Typ	Min	Max
A			2.28			0.090
B		0.51	0.71		0.020	0.028
D		11.23	11.63		0.442	0.458
E		13.72	14.22		0.540	0.560
e	1.27	–	–	0.050	–	–
e1		0.39	–		0.015	–
e2	7.62	–	–	0.300	–	–
e3	10.16	–	–	0.400	–	–
h	1.02	–	–	0.040	–	–
j	0.51	–	–	0.020	–	–
L		1.14	1.40		0.045	0.055
L1		1.96	2.36		0.077	0.093
K		10.50	10.80		0.413	0.425
K1		8.03	8.23		0.316	0.324
N		32			32	

Figure 10. LCCC32W - 32 lead Leadless Ceramic Chip Carrier, Package Outline

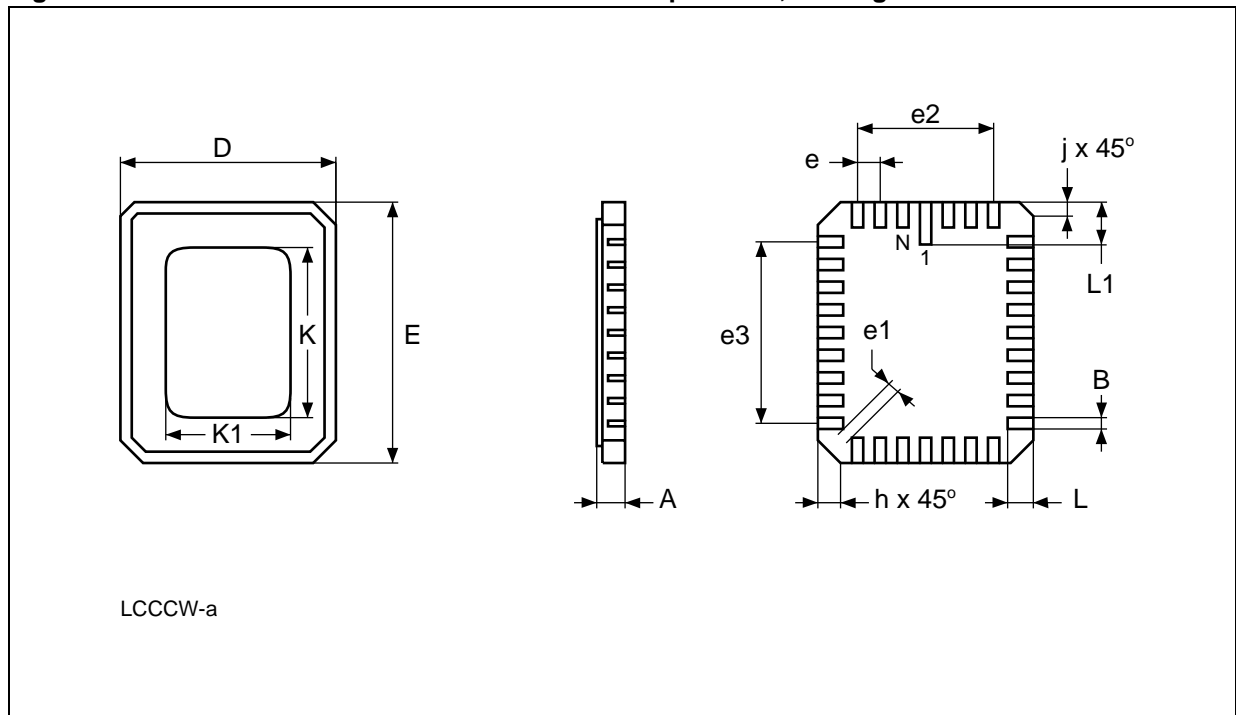

Drawing is not to scale.

Table 16. PLCC32 - 32 lead Plastic Leaded Chip Carrier, Package Mechanical Data

Symbol	Typ	millimeters		Typ	inches	
		Min	Max		Min	Max
A		3.18	3.56		0.125	0.140
A1		1.53	2.41		0.060	0.095
A2		0.38	–		0.015	–
B		0.33	0.53		0.013	0.021
B1		0.66	0.81		0.026	0.032
CP			0.10			0.004
D		12.32	12.57		0.485	0.495
D1		11.35	11.51		0.447	0.453
D2		4.78	5.66		0.188	0.223
D3	7.62	–	–	0.300	–	–
E		14.86	15.11		0.585	0.595
E1		13.89	14.05		0.547	0.553
E2		6.05	6.93		0.238	0.273
E3	10.16	–	–	0.400	–	–
e	1.27	–	–	0.050	–	–
F		0.00	0.13		0.000	0.005
N	32			32		
R	0.89	–	–	0.035	–	–

Figure 11. PLCC32 - 32 lead Plastic Leaded Chip Carrier, Package Outline

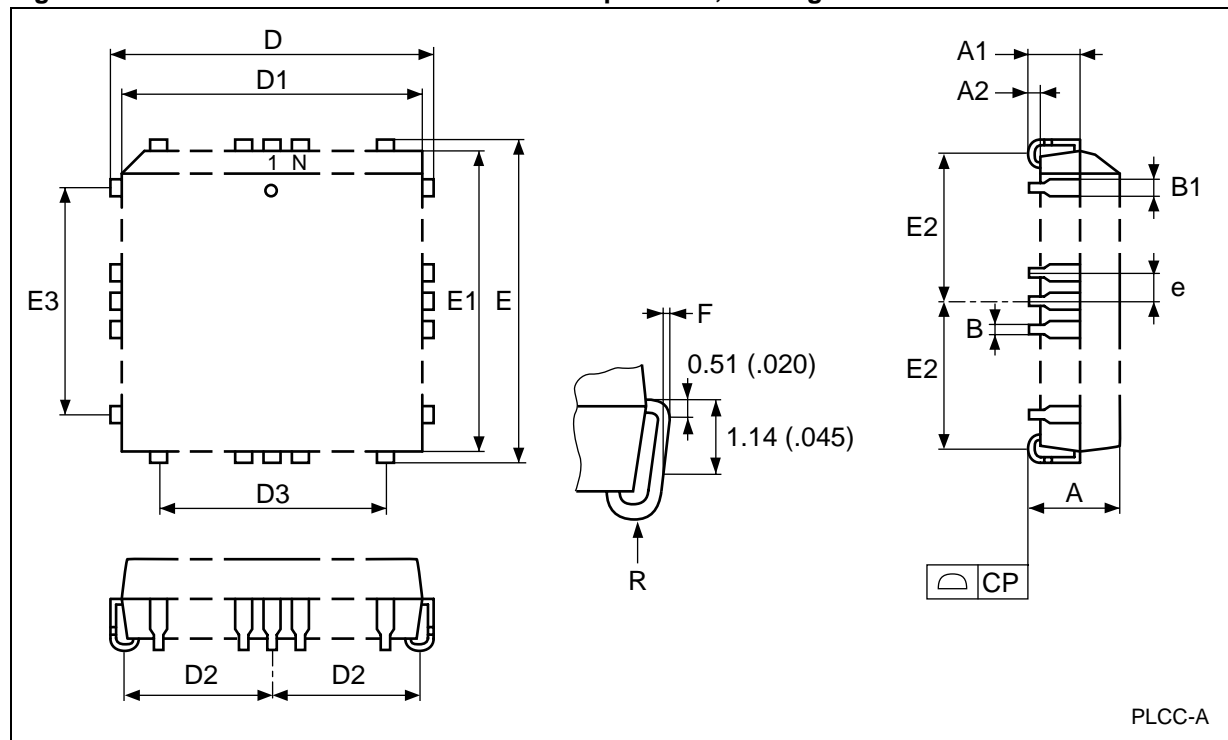

Drawing is not to scale.

Table 17. TSOP32 - 32 lead Plastic Thin Small Outline, 8 x 20 mm, Package Mechanical Data

Symbol	Typ	millimeters		Typ	inches	
		Min	Max		Min	Max
A			1.200			0.0472
A1		0.050	0.150		0.0020	0.0059
A2		0.950	1.050		0.0374	0.0413
B		0.170	0.250		0.0067	0.0098
C		0.100	0.210		0.0039	0.0083
CP			0.100			0.0039
D		19.800	20.200		0.7795	0.7953
D1		18.300	18.500		0.7205	0.7283
e	0.500	-	-	0.0197	-	-
E		7.900	8.100		0.3110	0.3189
L		0.500	0.700		0.0197	0.0276
$\alpha$		0°	5°		0°	5°
N		32			32	

Figure 12. TSOP32 - 32 lead Plastic Thin Small Outline, 8 x 20 mm, Package Outline

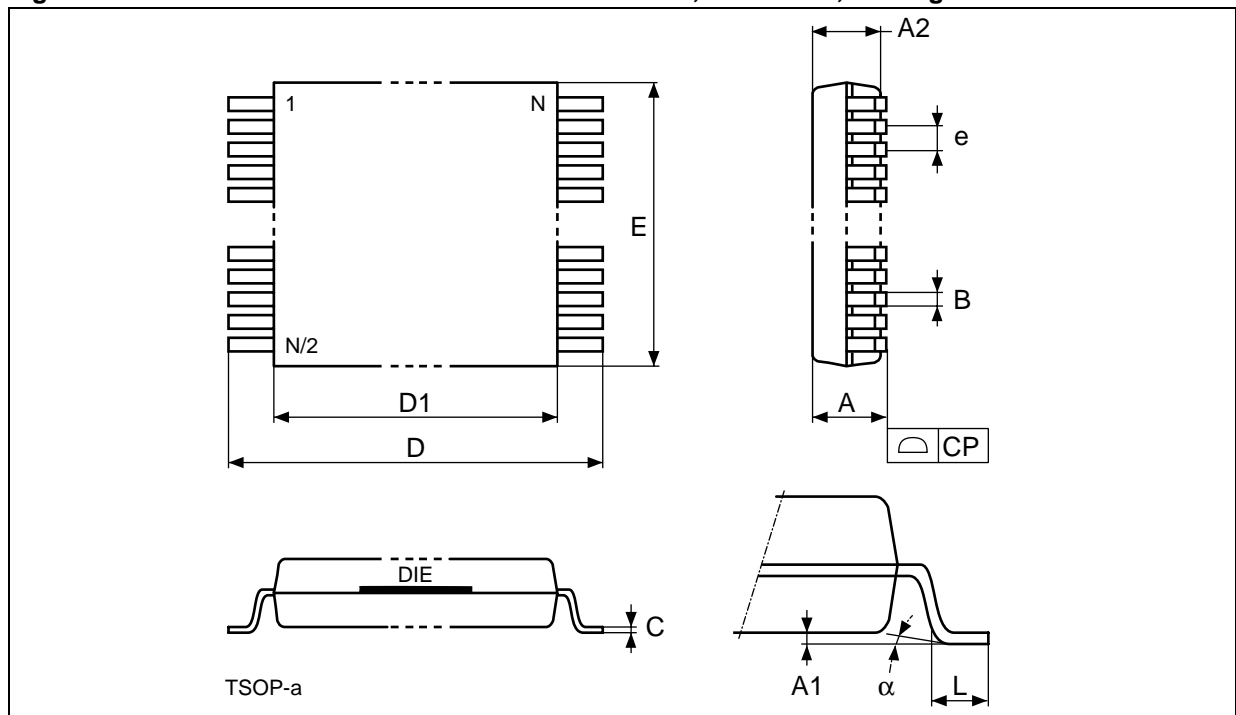

Drawing is not to scale.

Information furnished is believed to be accurate and reliable. However, STMicroelectronics assumes no responsibility for the consequences of use of such information nor for any infringement of patents or other rights of third parties which may result from its use. No license is granted by implication or otherwise under any patent or patent rights of STMicroelectronics. Specifications mentioned in this publication are subject to change without notice. This publication supersedes and replaces all information previously supplied. STMicroelectronics products are not authorized for use as critical components in life support devices or systems without express written approval of STMicroelectronics.

The ST logo is registered trademark of STMicroelectronics  
All other names are the property of their respective owners

© 2002 STMicroelectronics - All Rights Reserved

STMicroelectronics GROUP OF COMPANIES



Australia - Brazil - Canada - China - Finland - France - Germany - Hong Kong - India - Israel - Italy - Japan - Malaysia - Malta -  
Morocco - Singapore - Spain - Sweden - Switzerland - United Kingdom - United States

[www.st.com](http://www.st.com)



## Looking for pricing, stock, or lifecycle information?

Click below to explore more details on WIN SOURCE:

-  [View M27C1001-10B1 on WIN SOURCE](#)
-  [STMicroelectronics](#) Information

## Optimize Your Supply Chain with WIN SOURCE Solutions

-  Global Sourcing Solution
-  Obsolete Management
-  Cost Control Management
-  Shortage Management
-  Alternative Solution
-  Excess Inventory Management