



**THE DATASHEET OF
M25P128-VMF6PB**



M25P128 Serial Flash Embedded Memory with 54 MHz SPI Bus Interface

Features

- SPI bus-compatible serial interface
- 128Mb Flash memory
- 54 MHz clock frequency (maximum)
- 2.7V to 3.6V single supply voltage
- $V_{PP} = 9V$ for fast program/erase mode (optional)
- Page program (up to 256 bytes) in
 - 0.5ms (TYP)
 - 0.4ms (TYP with $V_{PP} = 9V$)
- Erase capability
 - Sector erase: 2Mb
 - Bulk erase: 128Mb
- Electronic signature
 - JEDEC-standard 2-byte signature (2018h)
- More than 100,000 PROGRAM/ERASE cycles per sector
- More than 20 years data retention
- Automotive-grade parts available
- Packages (RoHS-compliant)
 - VFDFPN8 (MLP8) 8mm x 6mm (Package code: ME)
 - SO16W 300 mils (Package code: MF)



Contents

Functional Description	5
Signal Descriptions	7
SPI Modes	8
Operating Features	10
Page Programming	10
Sector Erase, Bulk Erase	10
Polling during a Write, Program, or Erase Cycle	10
Fast Program/Erase Mode	10
Active Power and Standby Power	10
Status Register	11
Data Protection by Protocol	11
Software Data Protection	11
Hardware Data Protection	11
Hold Condition	12
Configuration and Memory Map	13
Memory Configuration and Block Diagram	13
Memory Map – 128Mb Density	14
Command Set Overview	15
WRITE ENABLE	17
WRITE DISABLE	18
READ IDENTIFICATION	19
READ STATUS REGISTER	20
WIP Bit	21
WEL Bit	21
Block Protect Bits	21
SRWD Bit	21
WRITE STATUS REGISTER	22
READ DATA BYTES	24
READ DATA BYTES at HIGHER SPEED	25
PAGE PROGRAM	26
SECTOR ERASE	27
BULK ERASE	28
Power-Up/Down and Supply Line Decoupling	29
Power-Up Timing and Write Inhibit Voltage Threshold Specifications	30
Initial Delivery Status	31
Maximum Ratings and Operating Conditions	32
Electrical Characteristics	33
AC Characteristics	34
Package Information	39
Device Ordering Information	41
Standard Parts	41
Revision History	42
Rev. A – 11/16	42

List of Figures

Figure 1: Logic Diagram	5
Figure 2: Pin Connections: VDFPN	5
Figure 3: Pin Connections: SO	6
Figure 4: SPI Modes Supported	8
Figure 5: Bus Master and Memory Devices on the SPI Bus	9
Figure 6: Hold Condition Activation	12
Figure 7: Block Diagram	13
Figure 8: WRITE ENABLE Command Sequence	17
Figure 9: WRITE DISABLE Command Sequence	18
Figure 10: READ IDENTIFICATION Command Sequence	19
Figure 11: READ STATUS REGISTER Command Sequence	20
Figure 12: Status Register Format	20
Figure 13: WRITE STATUS REGISTER Command Sequence	22
Figure 14: READ DATA BYTES Command Sequence	24
Figure 15: READ DATA BYTES at HIGHER SPEED Command Sequence	25
Figure 16: PAGE PROGRAM Command Sequence	26
Figure 17: SECTOR ERASE Command Sequence	27
Figure 18: BULK ERASE Command Sequence	28
Figure 19: Power-Up Timing	30
Figure 20: AC Measurement I/O Waveform	34
Figure 21: Serial Input Timing	36
Figure 22: Write Protect Setup and Hold during WRSR when SRWD = 1 Timing	37
Figure 23: Hold Timing	37
Figure 24: Output Timing	38
Figure 25: V_{PPH} Timing	38
Figure 26: VDFPN8 (MLP8) 8mm x 6mm – Package Code: ME	39
Figure 27: SO16W 300 mils Body Width – Package Code: MF	40



List of Tables

Table 1: Signal Descriptions	7
Table 2: Protected Area Sizes	11
Table 3: Sectors 63:0	14
Table 4: Command Set Codes	16
Table 5: READ IDENTIFICATION Data Out Sequence	19
Table 6: Status Register Protection Modes	23
Table 7: Power-Up Timing and V_{WI} Threshold	30
Table 8: Absolute Maximum Ratings	32
Table 9: Operating Conditions	32
Table 10: DC Current Specifications	33
Table 11: DC Voltage Specifications	33
Table 12: AC Measurement Conditions	34
Table 13: Capacitance	34
Table 14: AC Specifications	35
Table 15: AC Specifications, Command Times	36
Table 16: Part Number Information Scheme	41

Functional Description

The M25P128 is a 128Mb (16Mb x 8) serial Flash memory device with advanced write protection mechanisms accessed by a high speed SPI-compatible bus. The device supports high-performance commands for clock frequency up to 54 MHz.

The memory can be programmed 1 to 256 bytes at a time using the PAGE PROGRAM command. It is organized as 64 sectors, each containing 1024 pages. Each page is 256 bytes wide. Memory can be viewed either as 65,536 pages or as 16,777,216 bytes.

An enhanced fast program/erase mode is available to speed up operations in factory environment. The device enters this mode whenever the V_{PPH} voltage is applied to the $W\#/V_{PP}$ pin.

The entire memory can be erased using the BULK ERASE command, or it can be erased one sector at a time using the SECTOR ERASE command.

To meet environmental requirements, Micron offers these devices in lead-free and RoHS compliant packages.

Figure 1: Logic Diagram

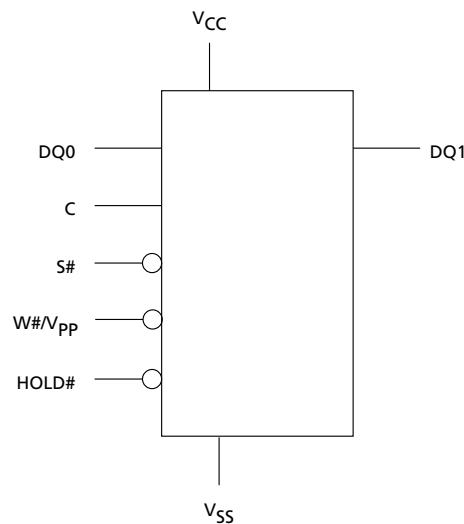
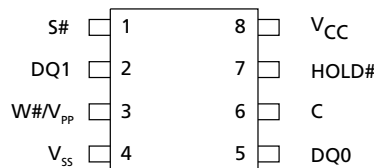
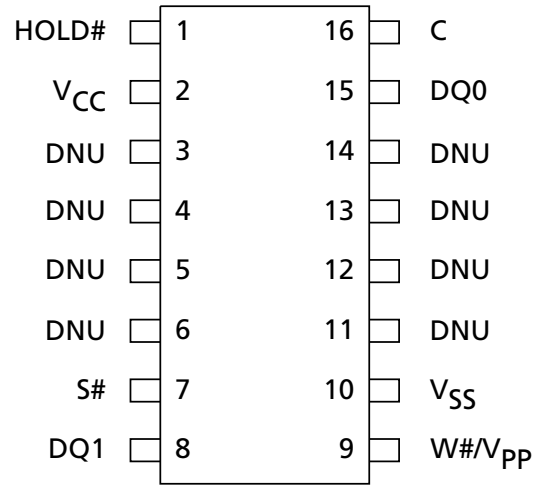

Figure 2: Pin Connections: VDFPN



- Note: 1. There is an exposed central pad on the underside of the MLP8 package that is pulled internally to V_{SS} , and must not be connected to any other voltage or signal line on the PCB. The Package Mechanical section provides information on package dimensions and how to identify pin 1.

Figure 3: Pin Connections: SO



- Notes:
1. DNU = Don't Use
 2. The Package Information section provides information on package dimensions and how to identify pin 1.

Signal Descriptions

Table 1: Signal Descriptions

Signal	Type	Description
DQ1	Output	Serial data: The DQ1 output signal is used to transfer data serially out of the device. Data is shifted out on the falling edge of the serial clock (C).
DQ0	Input	Serial data: The DQ0 input signal is used to transfer data serially into the device. It receives commands, addresses, and the data to be programmed. Values are latched on the rising edge of the serial clock (C).
C	Input	Clock: The C input signal provides the timing of the serial interface. Commands, addresses, or data present at serial data input (DQ0) is latched on the rising edge of the serial clock (C). Data on DQ1 changes after the falling edge of C.
S#	Input	Chip select: When the S# input signal is HIGH, the device is deselected and DQ1 is at high impedance. Unless an internal PROGRAM, ERASE, or WRITE STATUS REGISTER cycle is in progress, the device will be in the standby power mode. Driving S# LOW enables the device, placing it in the active power mode. After power-up, a falling edge on S# is required prior to the start of any command.
HOLD#	Input	Hold: The HOLD# signal is used to pause any serial communications with the device without deselecting the device. During the hold condition, DQ1 is High-Z. DQ0 and C are "Don't Care." To start the hold condition, the device must be selected, with S# driven LOW.
W#/V _{PP}	Input	Write protect: The W#/V _{PP} signal is both a control input and a power supply pin. The two functions are selected by the voltage range applied to the pin. If the W#/V _{PP} input is kept in a low voltage range (0 V to V _{CC}) the pin is seen as a control input. The W# input signal is used to freeze the size of the area of memory that is protected against program or erase commands as specified by the values in BP2, BP1, and BP0 bits of the Status Register. V _{PP} acts as an additional power supply if it is in the range of V _{PPH} , as defined in the AC Measurement Conditions table. Avoid applying V _{PPH} to the W#/V _{PP} pin during a BULK ERASE operation.
V _{CC}	Power	Device core power supply: Source voltage.
V _{SS}	Ground	Ground: Reference for the V _{CC} supply voltage.
DNU	–	Do not use.

SPI Modes

These devices can be driven by a microcontroller with its serial peripheral interface (SPI) running in either of the following two SPI modes:

- CPOL = 0, CPHA = 0
- CPOL = 1, CPHA = 1

For these two modes, input data is latched in on the rising edge of serial clock (C), and output data is available from the falling edge of C.

The difference between the two modes is the clock polarity when the bus master is in standby mode and not transferring data:

- C remains at 0 for (CPOL = 0, CPHA = 0)
- C remains at 1 for (CPOL = 1, CPHA = 1)

Figure 4: SPI Modes Supported

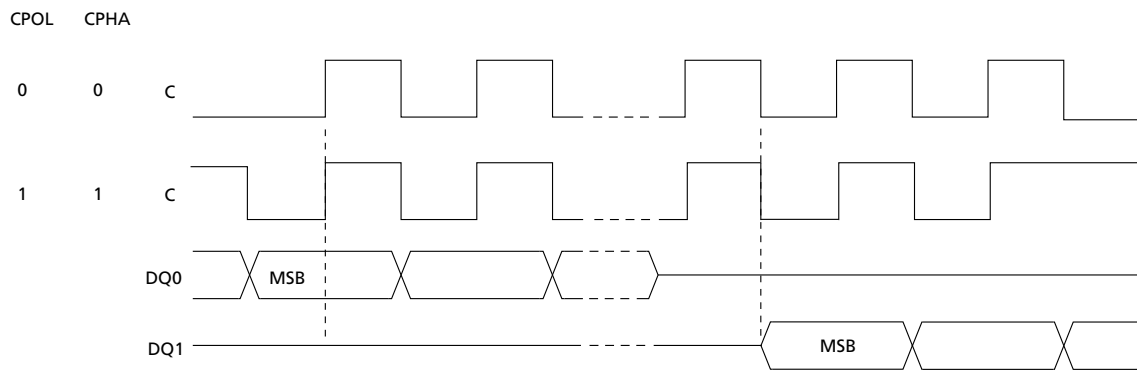

Because only one device is selected at a time, only one device drives the serial data output (DQ1) line at a time, while the other devices are High-Z. An example of three devices connected to an MCU on an SPI bus is shown here.

Figure 5: Bus Master and Memory Devices on the SPI Bus

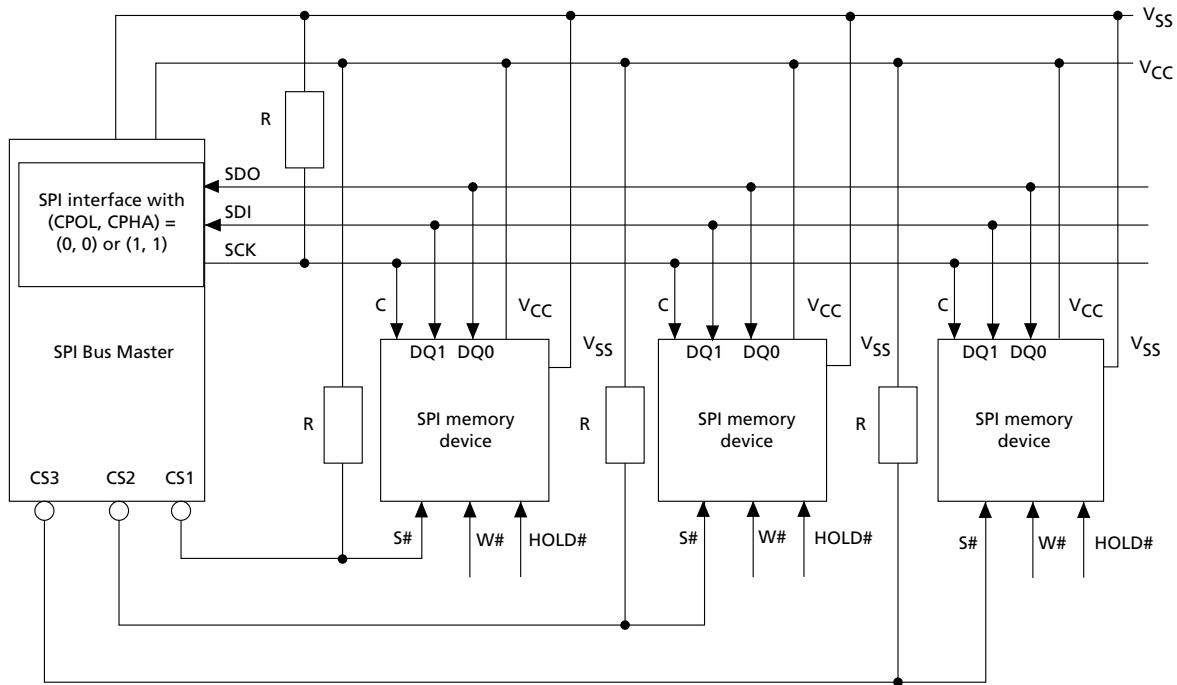

- Notes:
1. WRITE PROTECT (W#) and HOLD# should be driven HIGH or LOW as appropriate.
 2. Resistors (R) ensure that the memory device is not selected if the bus master leaves the S# line High-Z.
 3. The bus master may enter a state where all I/O are High-Z at the same time; for example, when the bus master is reset. Therefore, C must be connected to an external pull-down resistor so that when all I/O are High-Z, S# is pulled HIGH while C is pulled LOW. This ensures that S# and C do not go HIGH at the same time and that the ^tSHCH requirement is met.
 4. The typical value of R is 100kΩ, assuming that the time constant $R \times C_p$ (C_p = parasitic capacitance of the bus line) is shorter than the time during which the bus master leaves the SPI bus High-Z.
 5. Example: Given that $C_p = 50\text{pF}$ ($R \times C_p = 5\mu\text{s}$), the application must ensure that the bus master never leaves the SPI bus High-Z for a time period shorter than 5μs.

Operating Features

Page Programming

To program one data byte, two commands are required: WRITE ENABLE, which is one byte, and a PAGE PROGRAM sequence, which is four bytes plus data. This is followed by the internal PROGRAM cycle of duration t_{PP} . To spread this overhead, the PAGE PROGRAM command allows up to 256 bytes to be programmed at a time (changing bits from 1 to 0), provided they lie in consecutive addresses on the same page of memory. To optimize timings, it is recommended to use the PAGE PROGRAM command to program all consecutive targeted bytes in a single sequence than to use several PAGE PROGRAM sequences with each containing only a few bytes.

Sector Erase, Bulk Erase

The PAGE PROGRAM command allows bits to be reset from 1 to 0. Before this can be applied, the bytes of memory need to have been erased to all 1s (FFh). This can be achieved a sector at a time using the SECTOR ERASE command, or throughout the entire memory using the BULK ERASE command. This starts an internal ERASE cycle of duration t_{SSE} , t_{SE} , or t_{BE} . The ERASE command must be preceded by a WRITE ENABLE command.

Polling during a Write, Program, or Erase Cycle

An improvement in the time to complete the following commands can be achieved by not waiting for the worst case delay (t_W , t_{PP} , t_{SE} , or t_{BE}).

- WRITE STATUS REGISTER
- PROGRAM
- ERASE (SECTOR ERASE, BULK ERASE)

The write in progress (WIP) bit is provided in the status register so that the application program can monitor this bit in the status register, polling it to establish when the previous WRITE cycle, PROGRAM cycle, or ERASE cycle is complete.

Fast Program/Erase Mode

The fast program/erase mode is used to speed up programming/erasing. The device enters this mode during the PAGE PROGRAM, SECTOR ERASE, or BULK ERASE operations whenever a voltage equal to V_{PPH} is applied to the $W\#/V_{PP}$ pin.

The use of this mode requires specific operating conditions in addition to the normal ones (V_{CC} must be within the normal operating range):

- The voltage applied to the $W\#/V_{PP}$ pin must be equal to V_{PPH}
- Ambient temperature, T_A must be $25\text{ }^\circ\text{C} \pm 10\text{ }^\circ\text{C}$
- The cumulated time during which $W\#/V_{PP}$ is at V_{PPH} should be less than 80 hours

Active Power and Standby Power

When chip select ($S\#$) is LOW, the device is selected, and in the active power mode. When $S\#$ is HIGH, the device is deselected, but could remain in the active power mode until all internal cycles have completed (PROGRAM, ERASE, WRITE STATUS REGIS-

TER). The device then goes in to the standby power mode. The device consumption drops to I_{CC1} .

Status Register

The status register contains a number of status and control bits that can be read or set (as appropriate) by specific commands. For a detailed description of the status register bits, see READ STATUS REGISTER section.

Data Protection by Protocol

Nonvolatile memory is used in environments that can include excessive noise. The following capabilities help protect data in these noisy environments.

Power on reset and an internal timer (t_{PUW}) can provide protection against inadvertent changes while the power supply is outside the operating specification.

WRITE, PROGRAM, and WRITE STATUS REGISTER commands are checked before they are accepted for execution to ensure they consist of a number of clock pulses that is a multiple of eight.

All commands that modify data must be preceded by a WRITE ENABLE command to set the write enable latch (WEL) bit.

Software Data Protection

Memory can be configured as read-only using the block protect bits (BP2, BP1, BP0) as shown in the Protected Area Sizes table.

Hardware Data Protection

Hardware data protection is implemented using the write protect signal applied on the W# pin. This freezes the status register in a read-only mode. In this mode, the block protect (BP) bits and the status register write disable bit (SRWD) are protected.

Table 2: Protected Area Sizes

Status Register Content			Memory Content	
BP Bit 2	BP Bit 1	BP Bit 0	Protected Area	Unprotected Area
0	0	0	none	All sectors (sectors 0 to 63)
0	0	1	Upper 64th (sector 63, 2Mb)	Lower 63/64ths (sectors 0 to 62)
0	1	0	Upper 32nd (sectors 62 and 63, 4Mb)	Lower 31/32nds (sectors 0 to 61)
0	1	1	Upper 16th (sectors 60 and 63, 8Mb)	Lower 15/16ths (sectors 0 to 59)
1	0	0	Upper 8th (sectors 56 to 63, 16Mb)	Lower 7/8ths (sectors 0 to 55)
1	0	1	Upper 4th (sectors 48 to 63, 32Mb)	Lower 3/4ths (sectors 0 to 47)
1	1	0	Upper half (sectors 32 to 63, 64Mb)	Lower half (sectors 0 to 31)
1	1	1	All sectors (sectors 0 to 63, 128Mb)	none

Note: 1. 0 0 0 = unprotected area (sectors): The device is ready to accept a BULK ERASE command only if all block protect bits (BP2, BP1, BP0) are 0.

Hold Condition

The HOLD# signal is used to pause any serial communications with the device without resetting the clocking sequence. However, taking this signal LOW does not terminate any WRITE STATUS REGISTER, PROGRAM, or ERASE cycle that is currently in progress.

To enter the hold condition, the device must be selected, with S# LOW. The hold condition starts on the falling edge of the HOLD# signal, if this coincides with serial clock (C) being LOW. The hold condition ends on the rising edge of the HOLD# signal, if this coincides with C being LOW. If the falling edge does not coincide with C being LOW, the hold condition starts after C next goes LOW. Similarly, if the rising edge does not coincide with C being LOW, the hold condition ends after C next goes LOW.

During the hold condition, DQ1 is HIGH impedance while DQ0 and C are "Don't Care." Typically, the device remains selected with S# driven LOW for the duration of the hold condition. This ensures that the state of the internal logic remains unchanged from the moment of entering the hold condition. If S# goes HIGH while the device is in the hold condition, the internal logic of the device is reset. To restart communication with the device, it is necessary to drive HOLD# HIGH, and then to drive S# LOW. This prevents the device from going back to the hold condition.

Figure 6: Hold Condition Activation

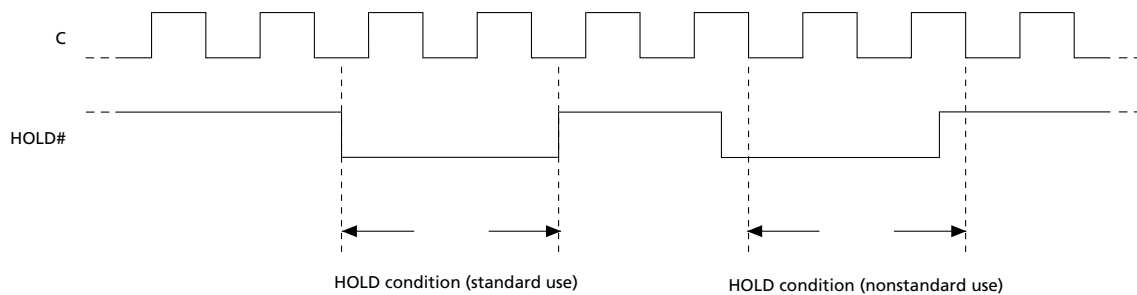

Configuration and Memory Map

Memory Configuration and Block Diagram

Each page of memory can be individually programmed; bits are programmed from 1 to 0. The device is sector or bulk-erasable, but not page-erasable; bits are erased from 0 to 1. The memory is configured as follows:

- 16,777,216 bytes (8 bits each)
- 64 sectors (2Mb, 262,144 bytes each)
- 65,536 pages (256 bytes each)

Figure 7: Block Diagram

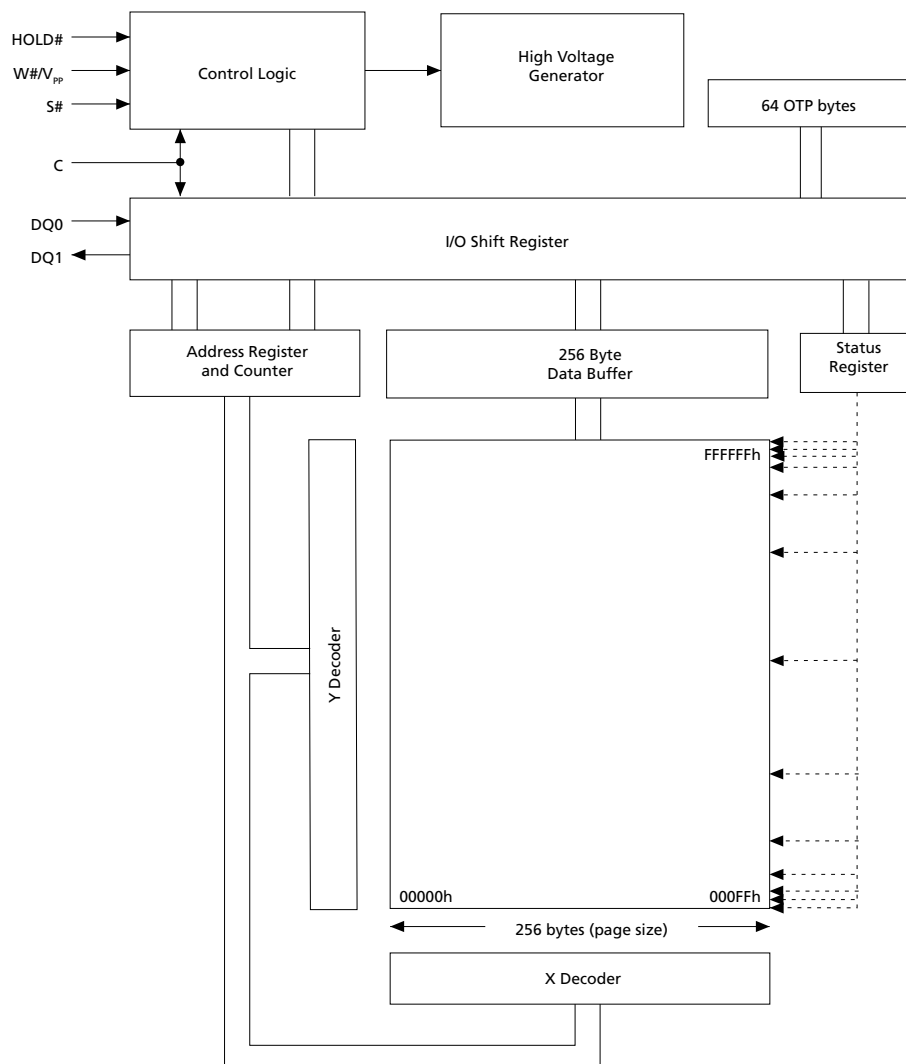



Memory Map – 128Mb Density

Table 3: Sectors 63:0

Sector	Address Range	
	Start	End
63	FC0000h	FFFFFFh
62	F80000h	FBFFFFh
⋮	⋮	⋮
48	C00000h	C3FFFFh
47	BC0000h	BFFFFFFh
⋮	⋮	⋮
32	800000h	83FFFFh
31	7C0000h	7FFFFFFh
⋮	⋮	⋮
16	400000h	43FFFFh
15	3C0000h	3FFFFFFh
⋮	⋮	⋮
0	000000h	03FFFFh

Command Set Overview

All commands, addresses, and data are shifted in and out of the device, most significant bit first.

Serial data inputs DQ0 and DQ1 are sampled on the first rising edge of serial clock (C) after chip select (S#) is driven LOW. Then, the one-byte command code must be shifted in to the device, most significant bit first, on DQ0 and DQ1, each bit being latched on the rising edges of C.

Every command sequence starts with a one-byte command code. Depending on the command, this command code might be followed by address or data bytes, by address and data bytes, or by neither address or data bytes. For the following commands, the shifted-in command sequence is followed by a data-out sequence. S# can be driven HIGH after any bit of the data-out sequence is being shifted out.

- READ DATA BYTES (READ)
- READ DATA BYTES at HIGHER SPEED
- READ STATUS REGISTER
- READ IDENTIFICATION

For the following commands, S# must be driven HIGH exactly at a byte boundary. That is, after an exact multiple of eight clock pulses following S# being driven LOW, S# must be driven HIGH. Otherwise, the command is rejected and not executed.

- PAGE PROGRAM
- SECTOR ERASE
- BULK ERASE
- WRITE STATUS REGISTER
- WRITE ENABLE
- WRITE DISABLE

All attempts to access the memory array are ignored during a WRITE STATUS REGISTER command cycle, a PROGRAM command cycle, or an ERASE command cycle. In addition, the internal cycle for each of these commands continues unaffected.



Table 4: Command Set Codes

Command Name	One-Byte Command Code		Bytes		
			Address	Dummy	Data
WRITE ENABLE	0000 0110	06h	0	0	0
WRITE DISABLE	0000 0100	04h	0	0	0
READ IDENTIFICATION	1001 1111	9Fh	0	0	1 to 20
	1001 1110	9Eh			
READ STATUS REGISTER	0000 0101	05h	0	0	1 to ∞
WRITE STATUS REGISTER	0000 0001	01h	0	0	1
READ DATA BYTES	0000 0011	03h	3	0	1 to ∞
READ DATA BYTES at HIGHER SPEED	0000 1011	0Bh	3	1	1 to ∞
PAGE PROGRAM	0000 0010	02h	3	0	1 to 256
SECTOR ERASE	1101 1000	D8h	3	0	0
BULK ERASE	1100 0111	C7h	0	0	0

WRITE ENABLE

The WRITE ENABLE command sets the write enable latch (WEL) bit.

The WEL bit must be set before execution of every PROGRAM, ERASE, and WRITE command.

The WRITE ENABLE command is entered by driving chip select (S#) LOW, sending the command code, and then driving S# HIGH.

Figure 8: WRITE ENABLE Command Sequence

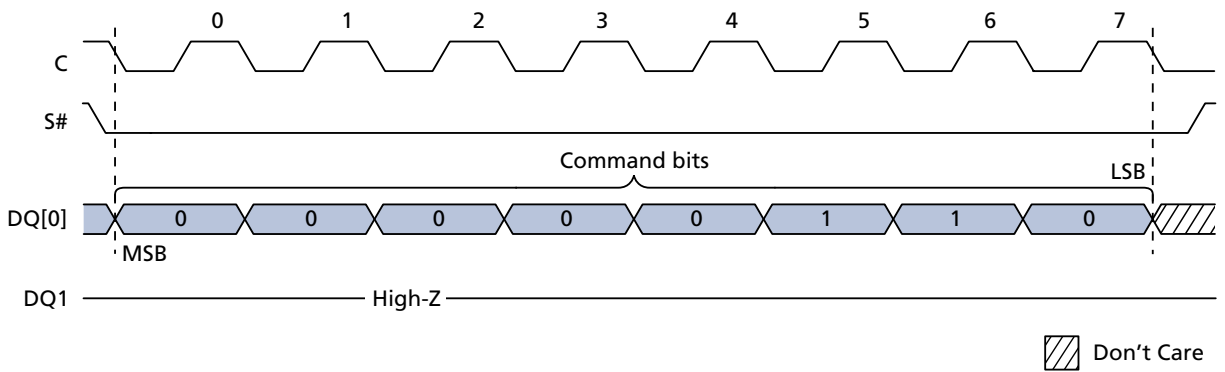

WRITE DISABLE

The WRITE DISABLE command resets the write enable latch (WEL) bit.

The WRITE DISABLE command is entered by driving chip select (S#) LOW, sending the command code, and then driving S# HIGH.

The WEL bit is reset under the following conditions:

- Power-up
- Completion of any ERASE operation
- Completion of any PROGRAM operation
- Completion of any WRITE STATUS REGISTER operation
- Completion of WRITE DISABLE operation

Figure 9: WRITE DISABLE Command Sequence

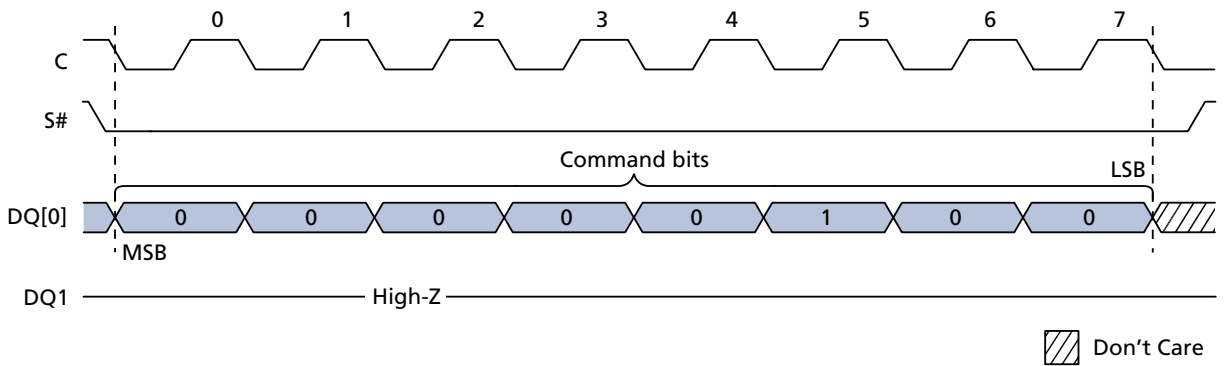

READ IDENTIFICATION

The READ IDENTIFICATION command reads the following device identification data:

- Manufacturer identification (1 byte): This is assigned by JEDEC.
- Device identification (2 bytes): This is assigned by device manufacturer; the first byte indicates memory type and the second byte indicates device memory capacity.

Table 5: READ IDENTIFICATION Data Out Sequence

Manufacturer Identification	Device Identification	
	Memory Type	Memory Capacity
20h	20h	18h

A READ IDENTIFICATION command is not decoded while an ERASE or PROGRAM cycle is in progress and has no effect on a cycle in progress.

The device is first selected by driving chip select (S#) LOW. Then the 8-bit command code is shifted in and the 24-bit device identification that is stored in the memory is shifted out on serial data output (DQ1). Each bit is shifted out during the falling edge of serial clock (C).

The READ IDENTIFICATION command is terminated by driving S# HIGH at any time during data output. When S# is driven HIGH, the device is put in the standby power mode and waits to be selected so that it can receive, decode, and execute commands.

Figure 10: READ IDENTIFICATION Command Sequence

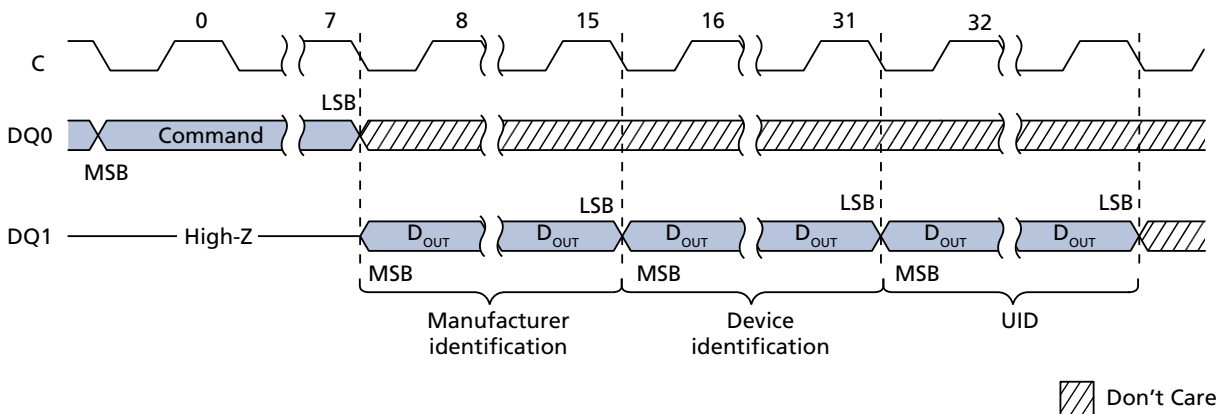

READ STATUS REGISTER

The READ STATUS REGISTER command allows the status register to be read. The status register may be read at any time, even while a PROGRAM, ERASE, or WRITE STATUS REGISTER cycle is in progress. When one of these cycles is in progress, it is recommended to check the write in progress (WIP) bit before sending a new command to the device. It is also possible to read the status register continuously.

Figure 11: READ STATUS REGISTER Command Sequence

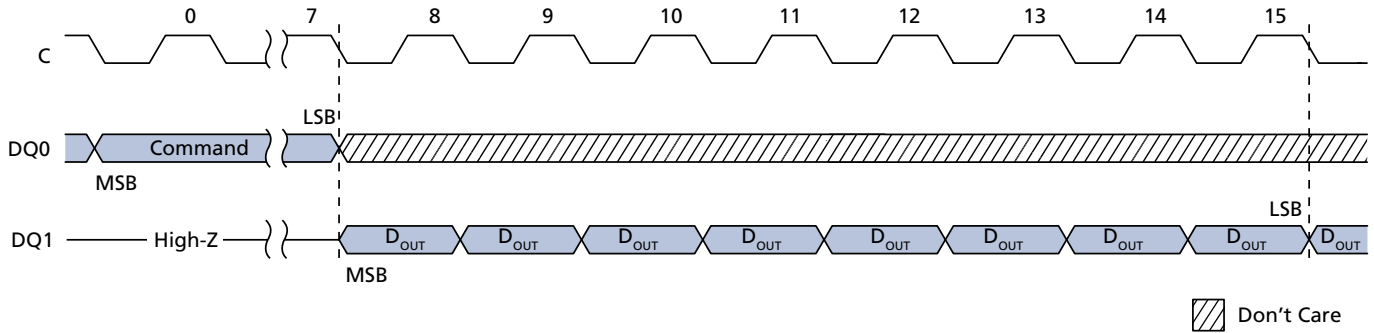
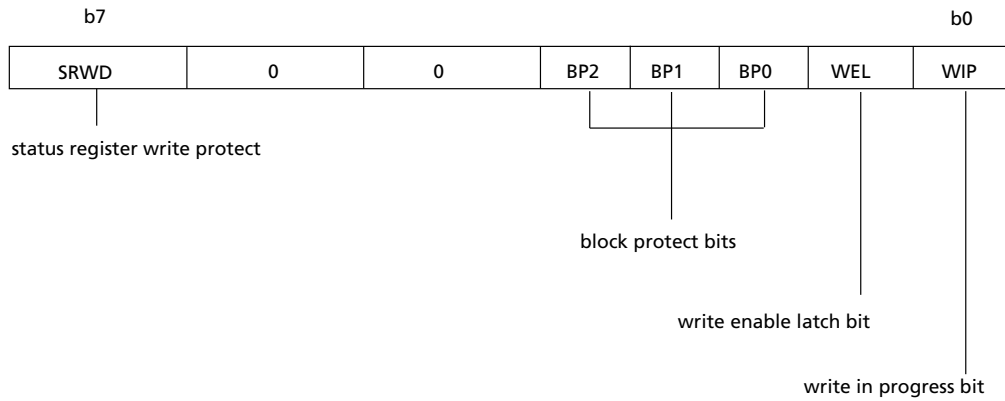

Figure 12: Status Register Format



WIP Bit

The write in progress (WIP) bit indicates whether the memory is busy with a WRITE STATUS REGISTER cycle, a PROGRAM cycle, or an ERASE cycle. When the WIP bit is set to 1, a cycle is in progress; when the WIP bit is set to 0, a cycle is not in progress.

WEL Bit

The write enable latch (WEL) bit indicates the status of the internal write enable latch. When the WEL bit is set to 1, the internal write enable latch is set; when the WEL bit is set to 0, the internal write enable latch is reset and no WRITE STATUS REGISTER, PROGRAM, or ERASE command is accepted.

Block Protect Bits

The block protect bits are non-volatile. They define the size of the area to be software protected against PROGRAM and ERASE commands. The block protect bits are written with the WRITE STATUS REGISTER command.

When one or more of the block protect bits is set to 1, the relevant memory area, as defined in the Protected Area Sizes table, becomes protected against PAGE PROGRAM and SECTOR ERASE commands. The block protect bits can be written provided that the hardware protected mode has not been set. The BULK ERASE command is executed only if all block protect bits are 0.

SRWD Bit

The status register write disable (SRWD) bit is operated in conjunction with the write protect ($W\#/V_{PP}$) signal. When the SRWD bit is set to 1 and $W\#/V_{PP}$ is driven LOW, the device is put in the hardware protected mode. In the hardware protected mode, the non-volatile bits of the status register (SRWD, and the block protect bits) become read-only bits and the WRITE STATUS REGISTER command is no longer accepted for execution.

WRITE STATUS REGISTER

The WRITE STATUS REGISTER command allows new values to be written to the status register. Before the WRITE STATUS REGISTER command can be accepted, a WRITE ENABLE command must have been executed previously. After the WRITE ENABLE command has been decoded and executed, the device sets the write enable latch (WEL) bit.

The WRITE STATUS REGISTER command is entered by driving chip select (S#) LOW, followed by the command code and the data byte on serial data input (DQ0). The WRITE STATUS REGISTER command has no effect on b6, b5, b4, b1, and b0 of the status register. The status register b6, b5, and b4 are always read as "0". S# must be driven HIGH after the eighth bit of the data byte has been latched in. If not, the WRITE STATUS REGISTER command is not executed.

Figure 13: WRITE STATUS REGISTER Command Sequence

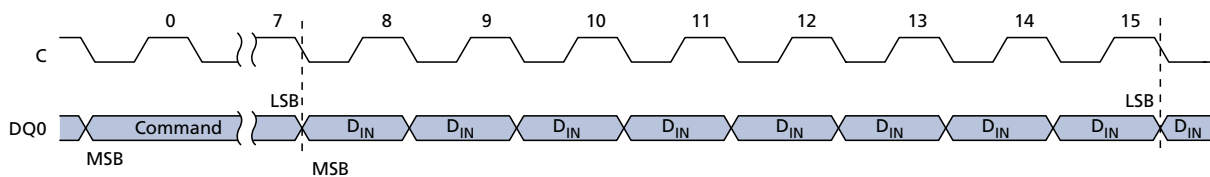

As soon as S# is driven HIGH, the self-timed WRITE STATUS REGISTER cycle is initiated; its duration is t^W . While the WRITE STATUS REGISTER cycle is in progress, the status register may still be read to check the value of the write in progress (WIP) bit. The WIP bit is 1 during the self-timed WRITE STATUS REGISTER cycle, and is 0 when the cycle is completed. Also, when the cycle is completed, the WEL bit is reset.

The WRITE STATUS REGISTER command allows the user to change the values of the block protect bits (BP2, BP1, BP0). Setting these bit values defines the size of the area that is to be treated as read-only, as defined in the Protected Area Sizes table.

The WRITE STATUS REGISTER command also allows the user to set and reset the status register write disable (SRWD) bit in accordance with the write protect ($W\#/V_{PP}$) signal. The SRWD bit and the $W\#/V_{PP}$ signal allow the device to be put in the hardware protected (HPM) mode. The WRITE STATUS REGISTER command is not executed once the HPM is entered. The options for enabling the status register protection modes are summarized here.

Table 6: Status Register Protection Modes

W#/V _{PP} Signal	SRWD Bit	Protection Mode (PM)	Status Register Write Protection	Memory Content		Notes
				Protected Area	Unprotected Area	
1	0	Software protected mode (SPM)	Software protection	Commands not accepted	Commands accepted	1, 2, 3
0	0					
1	1					
0	1	Hardware protected mode (HPM)	Hardware protection	Commands not accepted	Commands accepted	3, 4, 5,

- Notes:
1. Software protection: status register is writable (SRWD, BP2, BP1, and BP0 bit values can be changed) if the WRITE ENABLE command has set the WEL bit.
 2. PAGE PROGRAM, SECTOR ERASE, and BULK ERASE commands are not accepted.
 3. PAGE PROGRAM and SECTOR ERASE commands can be accepted.
 4. Hardware protection: status register is not writable (SRWD, BP2, BP1, and BP0 bit values cannot be changed).
 5. PAGE PROGRAM, SECTOR ERASE, and BULK ERASE commands are not accepted.

When the SRWD bit of the status register is 0 (its initial delivery state), it is possible to write to the status register provided that the WEL bit has been set previously by a WRITE ENABLE command, regardless of whether the W#/V_{PP} signal is driven HIGH or LOW. When the status register SRWD bit is set to 1, two cases need to be considered depending on the state of the W#/V_{PP} signal:

- If the W#/V_{PP} signal is driven HIGH, it is possible to write to the status register provided that the WEL bit has been set previously by a WRITE ENABLE command.
- If the W#/V_{PP} signal is driven LOW, it is not possible to write to the status register even if the WEL bit has been set previously by a WRITE ENABLE command. Therefore, attempts to write to the status register are rejected, and are not accepted for execution. The result is that all the data bytes in the memory area that have been put in SPM by the status register block protect bits (BP2, BP1, BP0) are also hardware protected against data modification.

Regardless of the order of the two events, the HPM can be entered in either of the following ways:

- Setting the status register SRWD bit after driving the W#/V_{PP} signal LOW
- Driving the W#/V_{PP} signal LOW after setting the status register SRWD bit.

The only way to exit the HPM is to pull the W#/V_{PP} signal HIGH. If the W#/V_{PP} signal is permanently tied HIGH, the HPM can never be activated. In this case, only the SPM is available, using the status register block protect bits (BP2, BP1, BP0).

READ DATA BYTES

The device is first selected by driving chip select (S#) LOW. The command code for READ DATA BYTES is followed by a 3-byte address (A23-A0), each bit being latched-in during the rising edge of serial clock (C). Then the memory contents at that address is shifted out on serial data output (DQ1), each bit being shifted out at a maximum frequency f^1R during the falling edge of C.

The first byte addressed can be at any location. The address is automatically incremented to the next higher address after each byte of data is shifted out. Therefore, the entire memory can be read with a single READ DATA BYTES command. When the highest address is reached, the address counter rolls over to 000000h, allowing the read sequence to be continued indefinitely.

The READ DATA BYTES command is terminated by driving S# HIGH. S# can be driven HIGH at any time during data output. Any READ DATA BYTES command issued while an ERASE, PROGRAM, or WRITE cycle is in progress is rejected without any effect on the cycle that is in progress.

Figure 14: READ DATA BYTES Command Sequence

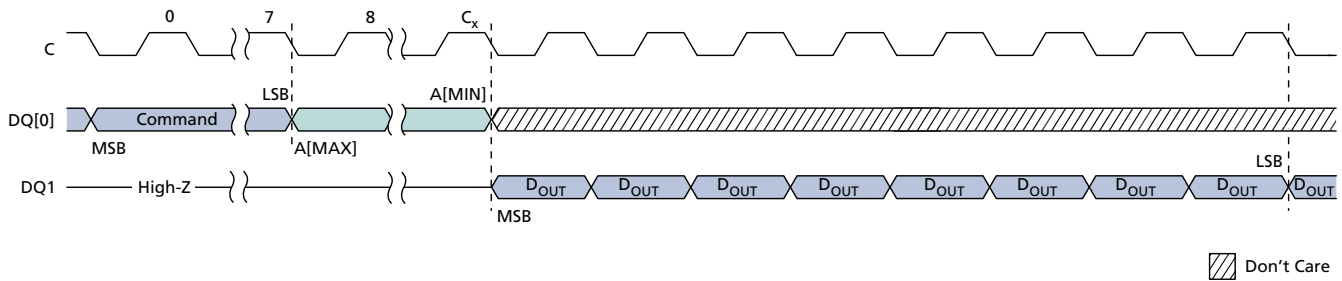

Note: 1. $C_x = 7 + (A[MAX] + 1)$.

READ DATA BYTES at HIGHER SPEED

The device is first selected by driving chip select (S#) LOW. The command code for the READ DATA BYTES at HIGHER SPEED command is followed by a 3-byte address (A23-A0) and a dummy byte, each bit being latched-in during the rising edge of serial clock (C). Then the memory contents at that address are shifted out on serial data output (DQ1) at a maximum frequency ^fC, during the falling edge of C.

The first byte addressed can be at any location. The address is automatically incremented to the next higher address after each byte of data is shifted out. Therefore, the entire memory can be read with a single READ DATA BYTES at HIGHER SPEED command. When the highest address is reached, the address counter rolls over to 000000h, allowing the read sequence to be continued indefinitely.

The READ DATA BYTES at HIGHER SPEED command is terminated by driving S# HIGH. S# can be driven HIGH at any time during data output. Any READ DATA BYTES at HIGHER SPEED command issued while an ERASE, PROGRAM, or WRITE cycle is in progress is rejected without any effect on the cycle that is in progress.

Figure 15: READ DATA BYTES at HIGHER SPEED Command Sequence

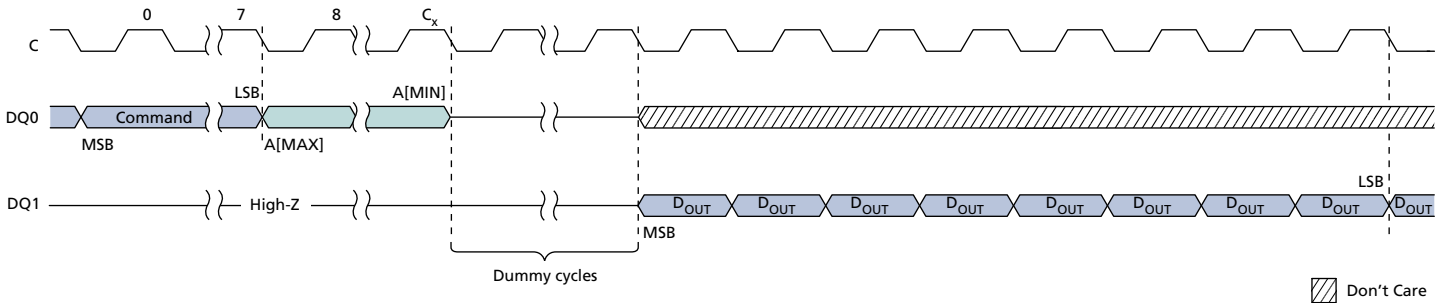

Note: 1. $C_x = 7 + (A[MAX] + 1)$.

PAGE PROGRAM

The PAGE PROGRAM command allows bytes in the memory to be programmed, which means the bits are changed from 1 to 0. Before a PAGE PROGRAM command can be accepted a WRITE ENABLE command must be executed. After the WRITE ENABLE command has been decoded, the device sets the write enable latch (WEL) bit.

The PAGE PROGRAM command is entered by driving chip select (S#) LOW, followed by the command code, three address bytes, and at least one data byte on serial data input (DQ0).

If the eight least significant address bits (A7-A0) are not all zero, all transmitted data that goes beyond the end of the current page are programmed from the start address of the same page; that is, from the address whose eight least significant bits (A7-A0) are all zero. S# must be driven LOW for the entire duration of the sequence.

If more than 256 bytes are sent to the device, previously latched data are discarded and the last 256 data bytes are guaranteed to be programmed correctly within the same page. If less than 256 data bytes are sent to device, they are correctly programmed at the requested addresses without any effects on the other bytes of the same page.

For optimized timings, it is recommended to use the PAGE PROGRAM command to program all consecutive targeted bytes in a single sequence rather than to use several PAGE PROGRAM sequences, each containing only a few bytes.

S# must be driven HIGH after the eighth bit of the last data byte has been latched in. Otherwise the PAGE PROGRAM command is not executed.

As soon as S# is driven HIGH, the self-timed PAGE PROGRAM cycle is initiated; the cycle's duration is t_{pp} . While the PAGE PROGRAM cycle is in progress, the status register may be read to check the value of the write in progress (WIP) bit. The WIP bit is 1 during the self-timed PAGE PROGRAM cycle, and 0 when the cycle is completed. At some unspecified time before the cycle is completed, the write enable latch (WEL) bit is reset.

A PAGE PROGRAM command is not executed if it applies to a page protected by the block protect bits BP2, BP1, and BP0.

Figure 16: PAGE PROGRAM Command Sequence

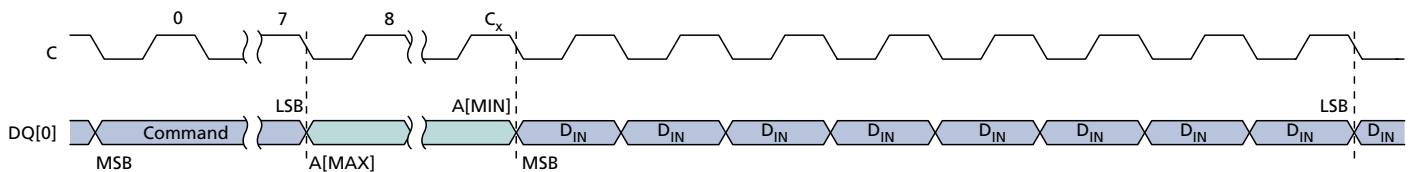

Note: 1. $C_x = 7 + (A[MAX] + 1)$.

SECTOR ERASE

The SECTOR ERASE command sets to 1 (FFh) all bits inside the chosen sector. Before the SECTOR ERASE command can be accepted, a WRITE ENABLE command must have been executed previously. After the WRITE ENABLE command has been decoded, the device sets the write enable latch (WEL) bit.

The SECTOR ERASE command is entered by driving chip select (S#) LOW, followed by the command code, and three address bytes on serial data input (DQ0). Any address inside the sector is a valid address for the SECTOR ERASE command. S# must be driven LOW for the entire duration of the sequence.

S# must be driven HIGH after the eighth bit of the last address byte has been latched in. Otherwise the SECTOR ERASE command is not executed. As soon as S# is driven HIGH, the self-timed SECTOR ERASE cycle is initiated; the cycle's duration is t_{SE} . While the SECTOR ERASE cycle is in progress, the status register may be read to check the value of the write in progress (WIP) bit. The WIP bit is 1 during the self-timed SECTOR ERASE cycle, and is 0 when the cycle is completed. At some unspecified time before the cycle is completed, the WEL bit is reset.

A SECTOR ERASE command is not executed if it applies to a sector that is hardware or software protected.

Figure 17: SECTOR ERASE Command Sequence

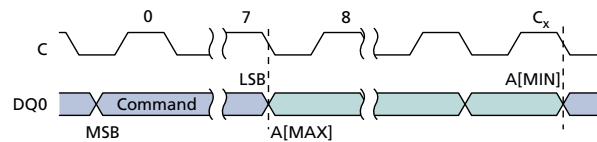

BULK ERASE

The BULK ERASE command sets all bits to 1 (FFh). Before the BULK ERASE command can be accepted, a WRITE ENABLE command must have been executed previously. After the WRITE ENABLE command has been decoded, the device sets the write enable latch (WEL) bit.

The BULK ERASE command is entered by driving chip select (S#) LOW, followed by the command code on serial data input (DQ0). S# must be driven LOW for the entire duration of the sequence.

S# must be driven HIGH after the eighth bit of the command code has been latched in. Otherwise the BULK ERASE command is not executed. As soon as S# is driven HIGH, the self-timed BULK ERASE cycle is initiated; the cycle's duration is t_{BE} . While the BULK ERASE cycle is in progress, the status register may be read to check the value of the write In progress (WIP) bit. The WIP bit is 1 during the self-timed BULK ERASE cycle, and is 0 when the cycle is completed. At some unspecified time before the cycle is completed, the WEL bit is reset.

The BULK ERASE command is executed only if all block protect (BP2, BP1, BP0) bits are 0. The BULK ERASE command is ignored if one or more sectors are protected.

Figure 18: BULK ERASE Command Sequence

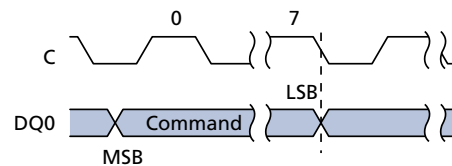

Power-Up/Down and Supply Line Decoupling

At power-up and power-down, the device must not be selected; that is, chip select (S#) must follow the voltage applied on V_{CC} until V_{CC} reaches the correct value:

- $V_{CC,min}$ at power-up, and then for a further delay of t_{VSL}
- V_{SS} at power-down

A safe configuration is provided in the SPI Modes section.

To avoid data corruption and inadvertent WRITE operations during power-up, a power-on-reset (POR) circuit is included. The logic inside the device is held reset while V_{CC} is less than the POR threshold voltage, V_{WI} – all operations are disabled, and the device does not respond to any instruction. Moreover, the device ignores the following instructions until a time delay of t_{PUW} has elapsed after the moment that V_{CC} rises above the V_{WI} threshold:

- WRITE ENABLE
- PAGE PROGRAM
- SECTOR ERASE
- BULK ERASE
- WRITE STATUS REGISTER

However, the correct operation of the device is not guaranteed if, by this time, V_{CC} is still below $V_{CC,min}$. No WRITE STATUS REGISTER, PROGRAM, or ERASE instruction should be sent until:

- t_{PUW} after V_{CC} has passed the V_{WI} threshold
- t_{VSL} after V_{CC} has passed the $V_{CC,min}$ level

If the time, t_{VSL} , has elapsed, after V_{CC} rises above $V_{CC,min}$, the device can be selected for READ instructions even if the t_{PUW} delay has not yet fully elapsed.

V_{PPH} must be applied only when V_{CC} is stable and in the $V_{CC,min}$ to $V_{CC,max}$ voltage range.

Figure 19: Power-Up Timing

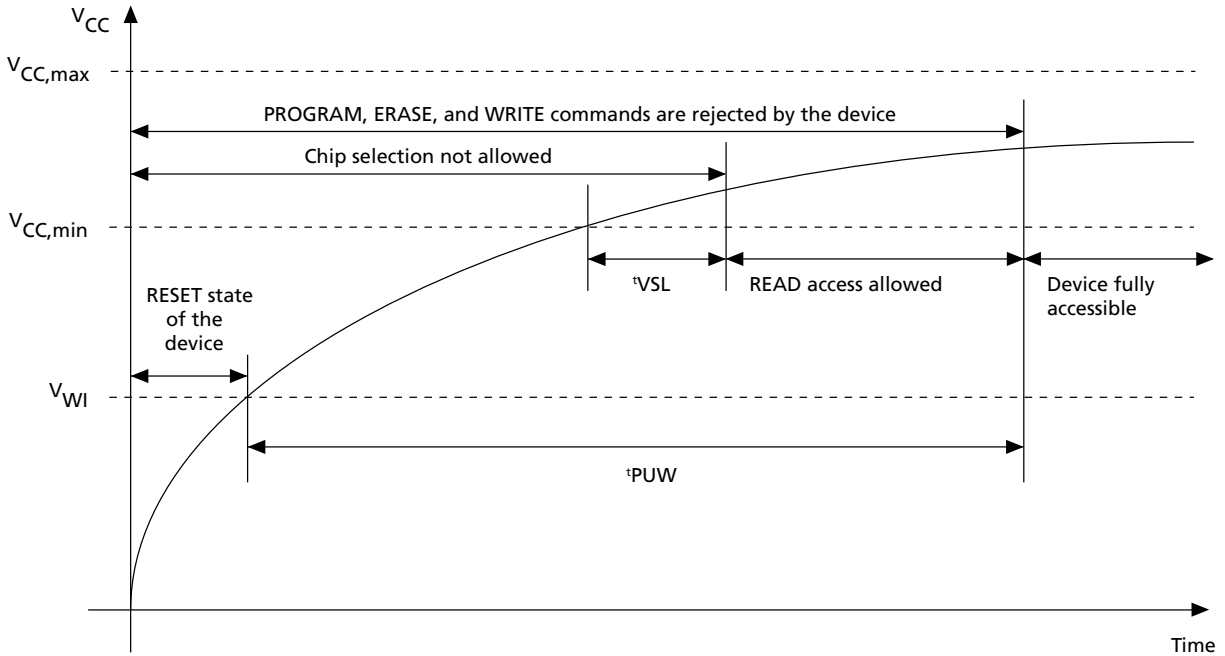

After power-up, the device is in the following state:

- Standby power mode
- Write enable latch (WEL) bit is reset

Normal precautions must be taken for supply line decoupling to stabilize the V_{CC} supply. Each device in a system should have the V_{CC} line decoupled by a suitable capacitor close to the package pins; generally, this capacitor is of the order of 0.1 μ F.

At power-down, when V_{CC} drops from the operating voltage to below the POR threshold voltage V_{WI} , all operations are disabled and the device does not respond to any instruction.

Note: If power-down occurs while a WRITE, PROGRAM, or ERASE cycle is in progress, some data corruption may result.

Power-Up Timing and Write Inhibit Voltage Threshold Specifications

Table 7: Power-Up Timing and V_{WI} Threshold

Symbol	Parameter	Min	Max	Unit
t_{VSL}	$V_{CC,min}$ to S# LOW	200	–	μ s
t_{PUW}	Time delay to WRITE instruction	400	–	μ s
V_{WI}	Write Inhibit voltage	1.5	2.5	V

Note: 1. Parameters are characterized only.

Initial Delivery Status

The device is delivered as the following:

- Memory array erased: all bits are set to 1 (each byte contains FFh)
- Status register contains 00h (all status register bits are 0)

Maximum Ratings and Operating Conditions

Note: Stressing the device beyond the absolute maximum ratings may cause permanent damage to the device. These are stress ratings only and operation of the device beyond any specification or condition in the operating sections of this datasheet is not recommended. Exposure to absolute maximum rating conditions for extended periods may affect device reliability.

Table 8: Absolute Maximum Ratings

Symbol	Parameter	Min	Max	Units	Notes
T _{STG}	Storage temperature	-65	150	°C	
V _{IO}	Input and output voltage (with respect to ground)	-0.5	V _{CC} + 0.6	V	1
V _{CC}	Supply voltage	-0.2	4.0	V	
V _{PP}	FAST PROGRAM and ERASE voltage	-0.2	10.0	V	
V _{ESD}	Electrostatic discharge voltage (Human Body model)	-2000	2000	V	2

- Notes:
1. The minimum voltage may reach the value of -2V for no more than 20ns during transitions; the maximum may reach the value of V_{CC} + 2V for no more than 20ns during transitions.
 2. The V_{ESD} signal: JEDEC Std JESD22-A114A (C1 = 100pF, R1 = 1500Ω, R2 = 500Ω).

Table 9: Operating Conditions

Symbol	Parameter	Min	Typ	Max	Unit
V _{CC}	Supply voltage	2.7	-	3.6	V
V _{PPH}	Supply voltage on W#/V _{PP} pin for FAST PROGRAM and ERASE	8.5	-	9.5	V
T _A	Ambient operating temperature	-40		85	°C
T _{AVPP}	Ambient operating temperature for FAST PROGRAM and ERASE	15	25	35	°C

Electrical Characteristics

Table 10: DC Current Specifications

Note 1 applies to the entire table.

Symbol	Parameter	Test Conditions	Min	Max	Units	Notes
I_{LI}	Input leakage current	–	–	± 2	μA	
I_{LO}	Output leakage current	–	–	± 2	μA	
I_{CC1}	Standby current	$S\# = V_{CC}, V_{IN} = V_{SS} \text{ or } V_{CC}$	–	100	μA	
I_{CC3}	Operating current (READ)	$C = 0.1 V_{CC}/0.9 V_{CC}$ at 50 MHz, DQ1 = Open	–	6	mA	
		$C = 0.1 V_{CC}/0.9 V_{CC}$ at 20 MHz, DQ1 = Open	–	4	mA	
I_{CC4}	Operating current (PAGE PROGRAM)	$S\# = V_{CC}$	–	20	mA	
I_{CC5}	Operating current (WRITE STATUS REGISTER)	$S\# = V_{CC}$	–	20	mA	
I_{CC6}	Operating current (SECTOR ERASE)	$S\# = V_{CC}$	–	20	mA	
I_{CC7}	Operating current (BULK ERASE)	$S\# = V_{CC}$	–	20	mA	
I_{CCPP}	Operating current (FAST PROGRAM/ERASE)	$S\# = V_{CC}, V_{pp} = V_{PPH}$	–	20	mA	1
I_{pp}	V_{pp} operating current (FAST PROGRAM/ERASE)	$S\# = V_{CC}, V_{pp} = V_{PPH}$	–	20	mA	1

Note: 1. Characterized only.

Table 11: DC Voltage Specifications

Symbol	Parameter	Test Conditions	Min	Max	Units
V_{IL}	Input LOW voltage	–	–0.5	$0.3 V_{CC}$	V
V_{IH}	Input HIGH voltage	–	$0.7 V_{CC}$	$V_{CC} + 0.2$	V
V_{OL}	Output LOW voltage	$I_{OL} = 1.6mA$	–	0.4	V
V_{OH}	Output HIGH voltage	$I_{OH} = -100\mu A$	$V_{CC} - 0.2$	–	V

AC Characteristics

In the following AC specifications, output High-Z is defined as the point where data out is no longer driven.

Table 12: AC Measurement Conditions

Symbol	Parameter	Min	Max	Unit
C_L	Load capacitance	30	30	pF
	Input rise and fall times	–	5	ns
	Input pulse voltages	$0.2 V_{CC}$	$0.8 V_{CC}$	V
	Input timing reference voltages	$0.3 V_{CC}$	$0.7 V_{CC}$	V
	Output timing reference voltages	$V_{CC}/2$	$V_{CC}/2$	V

Figure 20: AC Measurement I/O Waveform

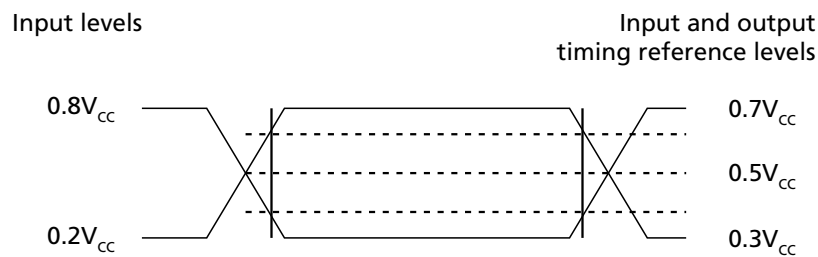

Table 13: Capacitance

Symbol	Parameter	Test condition	Min	Max	Unit	Notes
C_{OUT}	Output capacitance (DQ1)	$V_{OUT} = 0 V$	–	8	pF	1
C_{IN}	Input capacitance (other pins)	$V_{IN} = 0 V$	–	6	pF	

Note: 1. Values are sampled only, not 100% tested, at $T_A = 25^\circ C$ and a frequency of 20 MHz.

Table 14: AC Specifications

Symbol	Alt.	Parameter	Min	Typ	Max	Unit	Notes
f_C	f_C	Clock frequency for all commands (except READ)	D.C.	–	54	MHz	1
f_R	–	Clock frequency for READ command	D.C.	–	33	MHz	1
t_{CH}	t_{CLH}	Clock HIGH time	9	–	–	ns	2
t_{CL}	t_{CLL}	Clock LOW time	9	–	–	ns	2
t_{CLCH}	–	Clock rise time (peak to peak)	0.1	–	–	V/ns	3, 4
t_{CHCL}	–	Clock fall time (peak to peak)	0.1	–	–	V/ns	3, 4
t_{SLCH}	t_{CSS}	S# active setup time (relative to C)	4	–	–	ns	
t_{CHSL}		S# not active hold time (relative to C)	4	–	–	ns	
t_{DVCH}	t_{DSU}	Data In setup time	2	–	–	ns	
t_{CHDX}	t_{DH}	Data In hold time	3	–	–	ns	
t_{CHSH}	–	S# active hold time (relative to C)	4	–	–	ns	
t_{SHCH}	–	S# not active setup time (relative to C)	4	–	–	ns	
t_{SHSL}	t_{CSH}	S# deselect time	50	–	–	ns	
t_{SHQZ}	t_{DIS}	Output disable time	–	–	8	ns	3
t_{CLQV}	t_V	Clock LOW to output valid	–	–	8	ns	
t_{CLQX}	t_{HO}	Output hold time	1	–	–	ns	
t_{HLCH}	–	HOLD# setup time (relative to C)	4	–	–	ns	
t_{CHHH}	–	HOLD# hold time (relative to C)	4	–	–	ns	
t_{HHCH}	–	HOLD# setup time (relative to C)	4	–	–	ns	
t_{CHHL}	–	HOLD# hold time (relative to C)	4	–	–	ns	
t_{HHQX}	t_{LZ}	HOLD# to output Low-Z	–	–	8	ns	3
t_{HLQZ}	t_{HZ}	HOLD# to output High-Z	–	–	8	ns	3
t_{WHSL}	–	Write protect setup time	20	–	–	ns	5
t_{SHWL}	–	Write protect hold time	100	–	–	ns	5
t_{VPPHSL}	–	Enhanced program supply voltage HIGH to chip select LOW	200	–	–	ns	6

- Notes:
1. D.C. stands for direct current. ($f_C = 0$)
 2. The t_{CH} and t_{CL} signal values must be greater than or equal to $1/f_C$.
 3. Signal values are guaranteed by characterization, not 100% tested in production.
 4. Signal clock rise and fall time values are expressed as a slew rate.
 5. Signal values are only applicable as a constraint for a WRITE STATUS REGISTER command when SRWD bit is set at 1.
 6. V_{PPH} should be kept at a valid level until the PROGRAM or ERASE operation has completed and its result (success or failure) is known.

Table 15: AC Specifications, Command Times

Symbol	Parameter	Min	Typ	Max	Units	Notes
t^w	WRITE STATUS REGISTER cycle time	–	1.3	15	ms	
t^{pp}	PAGE PROGRAM cycle time (256 bytes)	–	0.5	5	ms	1
t^{pp}	PAGE PROGRAM cycle time (n bytes)	–	$\text{int}(n/8) \times 0.015$	5	ms	1, 2
t^{pp}	PAGE PROGRAM cycle time ($V_{pp} = V_{ppH}$, 256 bytes)	–	0.4	5	ms	1, 3
t^{se}	SECTOR ERASE cycle time	–	1.6	3 (after 10K ERASE cycles) 5 (after 50K ERASE cycles) 6 (after 100K ERASE cycles)	s	
t^{se}	SECTOR ERASE cycle time ($V_{pp} = V_{ppH}$)	–	1.6	3 (after 10K ERASE cycles) 5 (after 50K ERASE cycles) 6 (after 100K ERASE cycles)	s	
t^{be}	BULK ERASE cycle time	–	130	250	s	
t^{be}	BULK ERASE cycle time ($V_{pp} = V_{ppH}$)	–	130	250	s	

- Notes:
1. When using the PAGE PROGRAM command to program consecutive bytes, optimized timings are obtained in one sequence that includes all the bytes rather than in several sequences of only a few bytes ($1 \leq n \leq 256$).
 2. $\text{int}(A)$ corresponds to the upper integer part of A . For example, $\text{int}(12/8) = 2$ and $\text{int}(32/8) = 4$.
 3. Signal values are guaranteed by characterization, not 100% tested in production.

Figure 21: Serial Input Timing

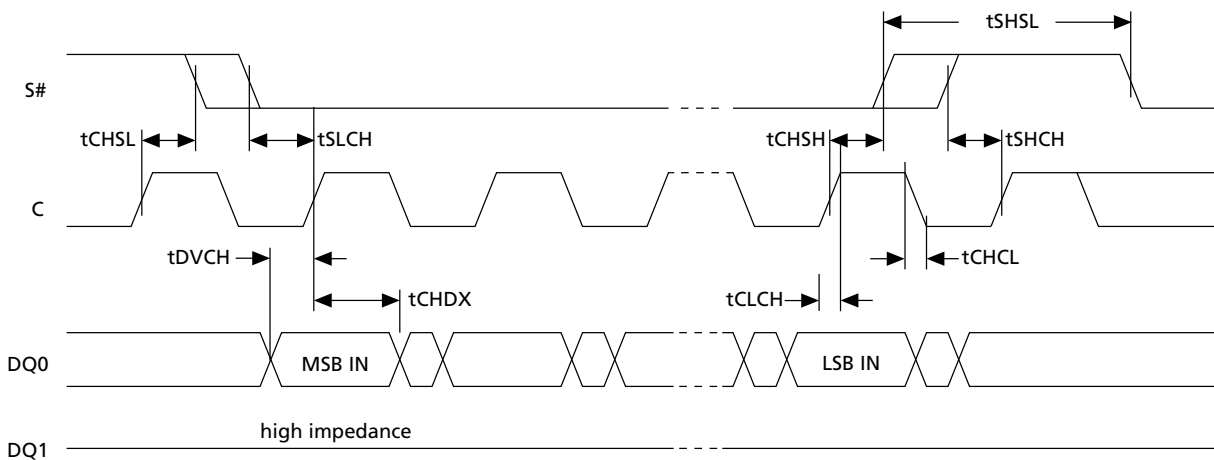

Figure 22: Write Protect Setup and Hold during WRSR when SRWD = 1 Timing

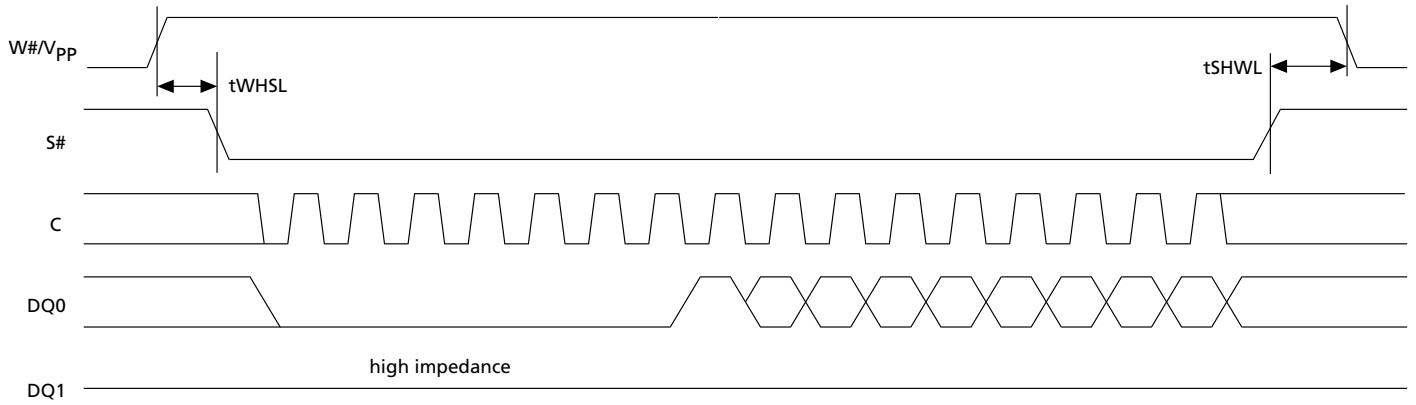

Figure 23: Hold Timing

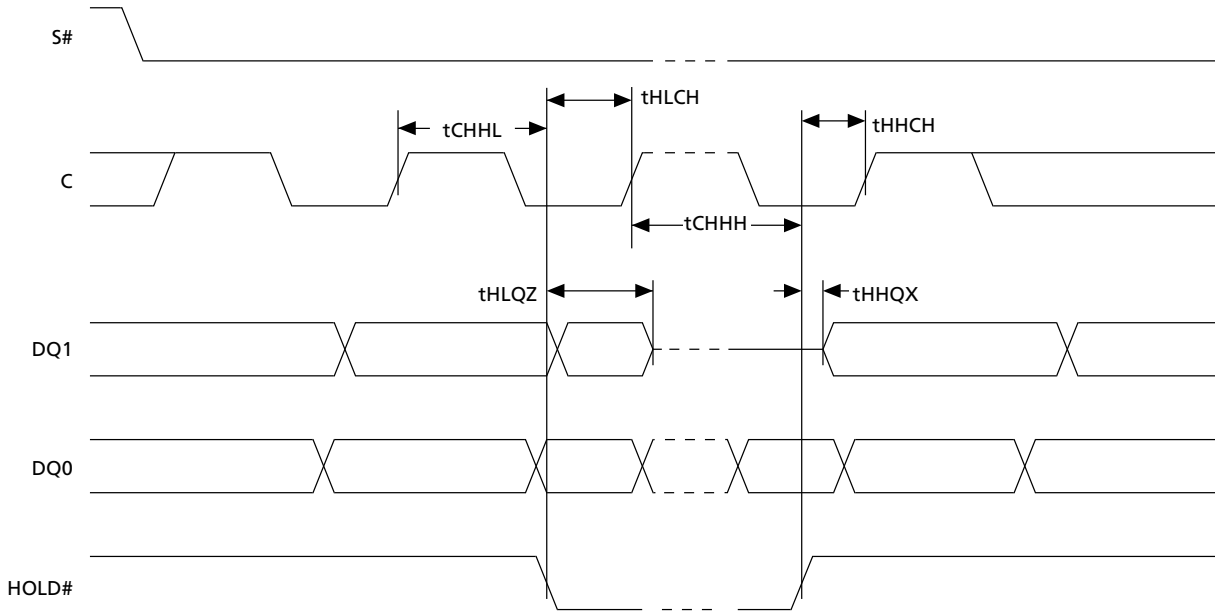

Figure 24: Output Timing

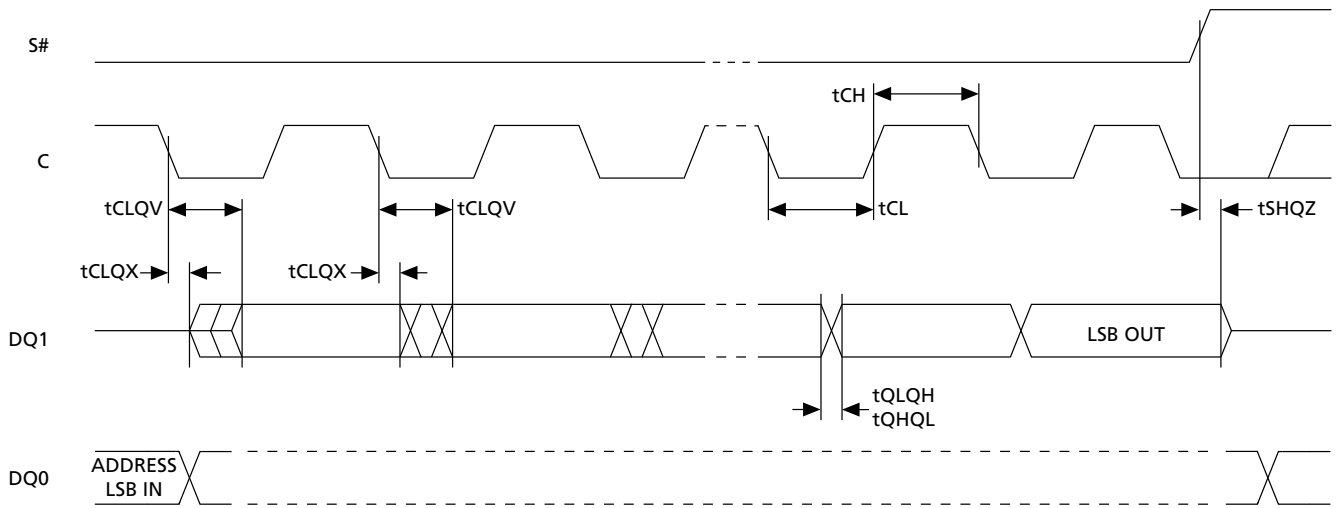
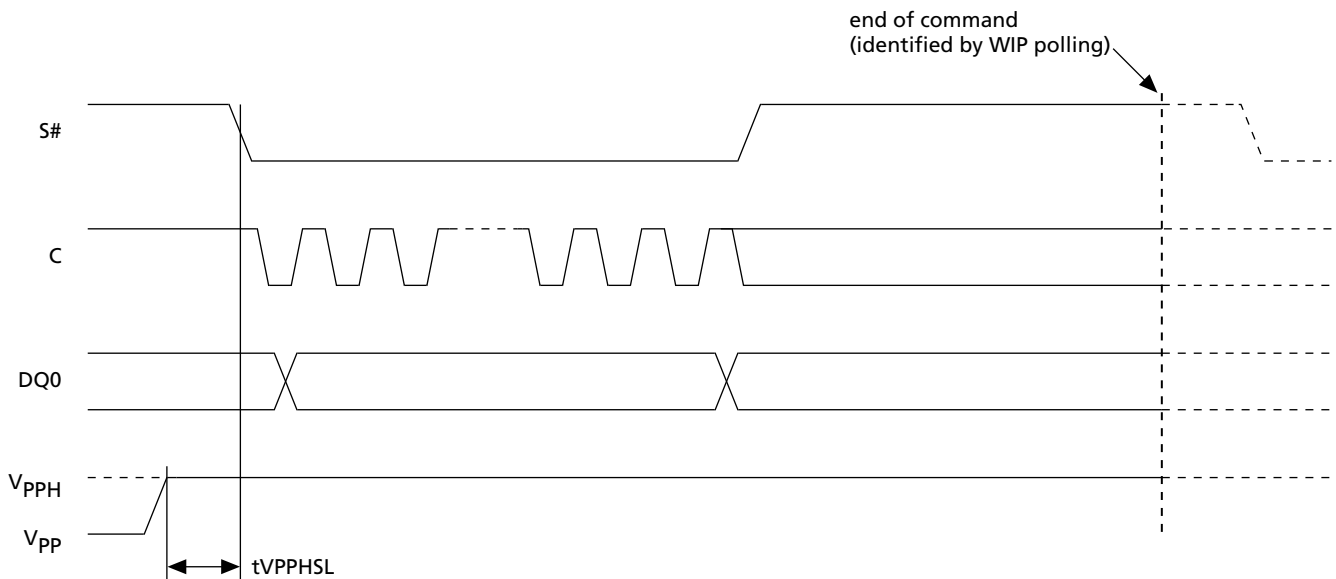
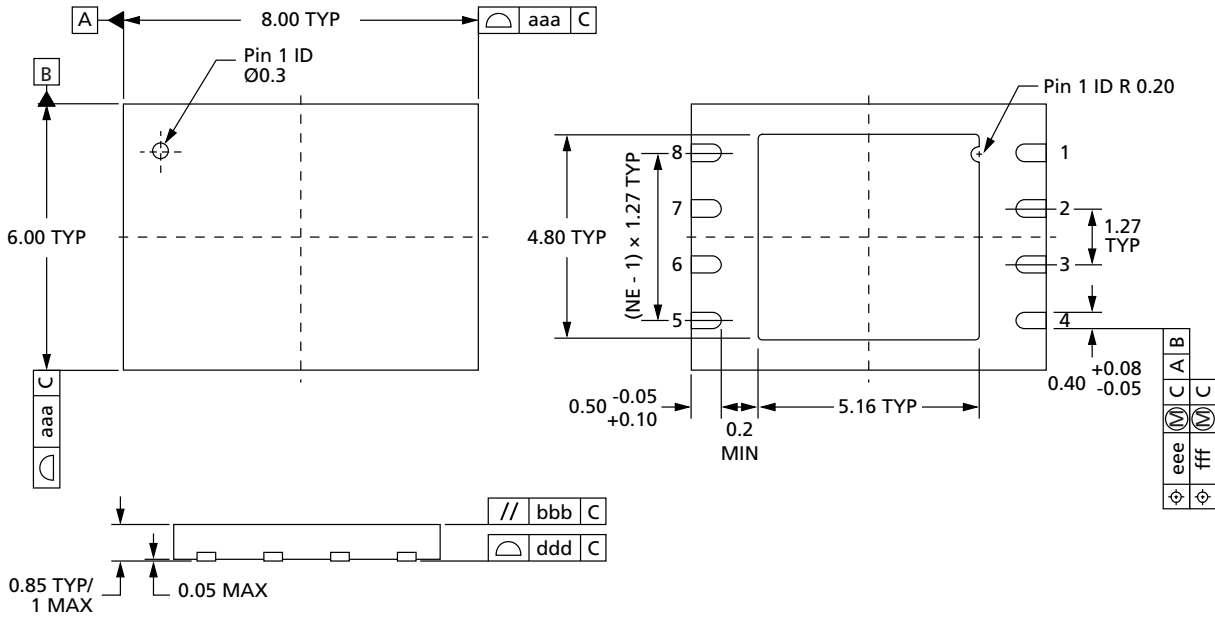

Figure 25: V_{PPH} Timing



Package Information

Figure 26: VFDFPN8 (MLP8) 8mm x 6mm – Package Code: ME



Note: 1. Drawing is not to scale.

Figure 27: SO16W 300 mils Body Width – Package Code: MF

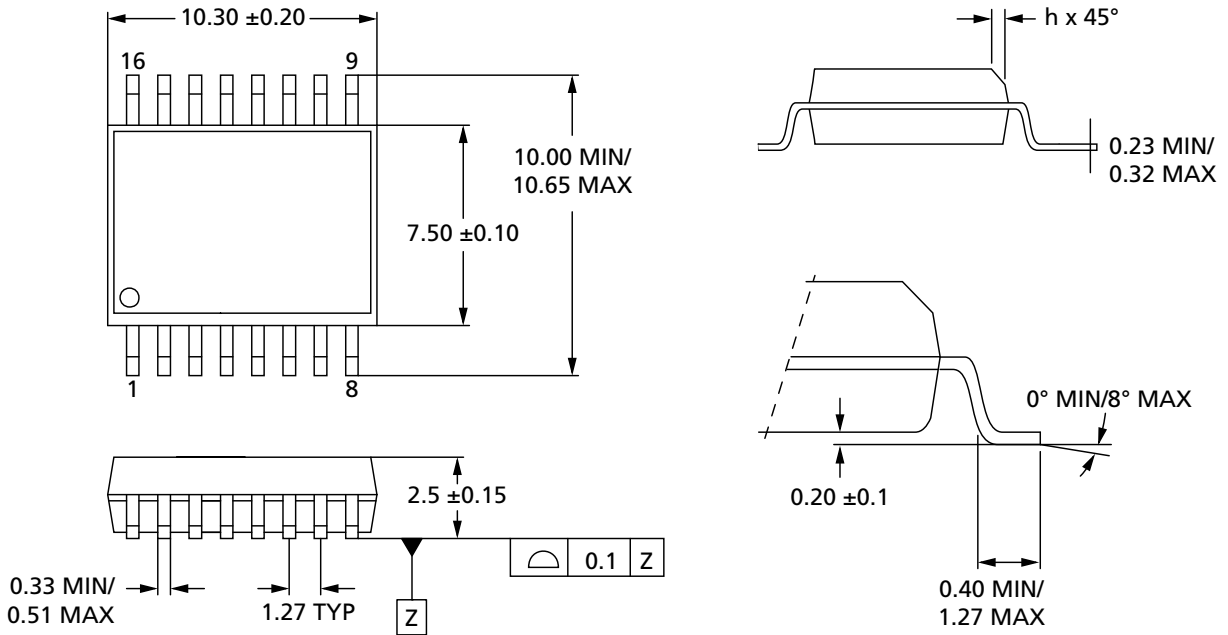

Note: 1. $h = 0.25\text{mm MIN}, 0.75\text{mm MAX}$



Device Ordering Information

Standard Parts

For further information on line items not listed here or on any aspect of this device, contact your nearest representative.

Table 16: Part Number Information Scheme

Part Number Category	Category Details
Device type	M25P = Serial Flash memory for code storage
Density	128 = 128Mb (16Mb x 8)
Operating voltage	V = V _{CC} = 2.7V to 3.6V
Package	ME = VFDFPN8 8mm x 6mm (MLP8)
	MF = SO16W (300 mils width)
Device grade	6 = Industrial temperature range: -40°C to 85°C. Device tested with standard test flow.
Packing option	- = Standard packing
	T = Tape and reel packing
Plating technology	P or G = RoHS-compliant
Lithography	B = 65nm SLC

Note: 1. The category of second Level Interconnect is marked on the package and on the inner box label, in compliance with JEDEC Standard JESD97. The maximum ratings related to soldering conditions are also marked on the inner box label.



Revision History

Rev. A – 11/16



- Initial Micron rebrand.

8000 S. Federal Way, P.O. Box 6, Boise, ID 83707-0006, Tel: 208-368-4000
www.micron.com/products/support Sales inquiries: 800-932-4992
Micron and the Micron logo are trademarks of Micron Technology, Inc.
All other trademarks are the property of their respective owners.

This data sheet contains minimum and maximum limits specified over the power supply and temperature range set forth herein.
Although considered final, these specifications are subject to change, as further product development and data characterization some-
times occur.

Looking for pricing, stock, or lifecycle information?

Click below to explore more details on WIN SOURCE:

-  [View M25P128-VMF6PB on WIN SOURCE](#)
-  [Micron Technology Inc. Information](#)

Optimize Your Supply Chain with WIN SOURCE Solutions

-  Global Sourcing Solution
-  Obsolete Management
-  Cost Control Management
-  Shortage Management
-  Alternative Solution
-  Excess Inventory Management