



**THE DATASHEET OF
M25P128-VMF6P**



Features

- 128-Mbit flash memory
- 2.7 to 3.6 V single supply voltage
- SPI bus compatible serial interface
- 54 MHz clock rate (maximum) for 65 nm devices
- $V_{PP} = 9\text{ V}$ for fast program/erase mode (optional)
- Page program (up to 256 Bytes):
 - in 0.5 ms (typical) for 65 nm devices
 - in 0.4 ms (typical with $V_{PP} = 9\text{ V}$) for 65 nm devices
- Sector erase (2 Mbit)
- Bulk erase (128 Mbit)
- Electronic signature
 - JEDEC standard two-byte signature (2018h)
- More than 10,000 erase/program cycles per sector
- More than 20-year data retention
- RoHS compliant packages

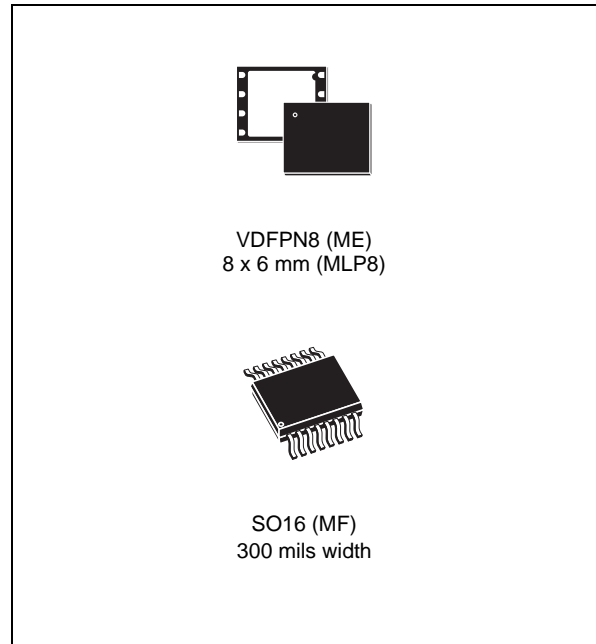

Contents

1	Description	6
2	Signal description	8
2.1	Serial data output (Q)	8
2.2	Serial data input (D)	8
2.3	Serial clock (C)	8
2.4	Chip Select (\overline{S})	8
2.5	Hold (\overline{HOLD})	8
2.6	Write protect/enhanced program supply voltage (\overline{W}/V_{PP})	9
2.7	V_{CC} supply voltage	9
2.8	V_{SS} ground	9
3	SPI modes	10
4	Operating features	12
4.1	Page programming	12
4.2	Sector erase and bulk erase	12
4.3	Polling during a write, program or erase cycle	12
4.4	Fast program/erase mode	12
4.5	Active power and standby power modes	13
4.6	Status register	13
4.7	Protection modes	13
4.8	Hold condition	14
5	Memory organization	16
6	Instructions	19
6.1	Write enable (WREN)	20
6.2	Write disable (WRDI)	20
6.3	Read identification (RDID)	21
6.4	Read status register (RDSR)	22
6.4.1	WIP bit	22

6.4.2	WEL bit	22
6.4.3	BP2, BP1, BP0 bits	22
6.4.4	SRWD bit	22
6.5	Write status register (WRSR)	24
6.6	Read data bytes (READ)	26
6.7	Read data bytes at higher speed (FAST_READ)	27
6.8	Page program (PP)	28
6.9	Sector erase (SE)	30
6.10	Bulk erase (BE)	31
7	Power-up and power-down	32
8	Initial delivery state	33
9	Maximum rating	34
10	DC and AC parameters	35
11	Package mechanical	43
12	Ordering information	45
13	Revision history	46

List of tables

Table 1.	Signal names	7
Table 2.	Protected area sizes	14
Table 3.	Memory organization	17
Table 4.	Instruction set	19
Table 5.	Read identification (RDID) data-out sequence	21
Table 6.	Status register format	22
Table 7.	Protection modes	24
Table 8.	Power-up timing and VWI threshold for 65 nm devices	33
Table 9.	Power-up timing and VWI threshold for 130 nm devices	33
Table 10.	Absolute maximum ratings	34
Table 11.	Operating conditions	35
Table 12.	AC measurement conditions	35
Table 13.	Capacitance	35
Table 14.	DC characteristics for 65 nm devices	36
Table 15.	AC characteristics for 65 nm devices	36
Table 16.	DC characteristics for 130 nm devices	38
Table 17.	AC characteristics for 130 nm devices	39
Table 18.	VDFPN8 (MLP8), 8-lead Very thin Dual Flat Package No lead, 8 × 6mm, package mechanical data	43
Table 19.	SO16 wide – 16 lead Plastic Small Outline, 300 mils body width	44
Table 20.	Ordering information scheme	45
Table 21.	Document revision history	46

List of figures

Figure 1.	Logic diagram	6
Figure 2.	VDFPN connections	7
Figure 3.	SO connections	7
Figure 4.	Bus master and memory devices on the SPI bus	10
Figure 5.	SPI modes supported	11
Figure 6.	Hold condition activation	15
Figure 7.	Block diagram	16
Figure 8.	Write enable (WREN) instruction sequence	20
Figure 9.	Write disable (WRDI) instruction sequence	20
Figure 10.	Read identification (RDID) instruction sequence and data-out sequence	21
Figure 11.	Read status register (RDSR) instruction sequence and data-out sequence	23
Figure 12.	Write status register (WRSR) instruction sequence	25
Figure 13.	Read data bytes (READ) instruction sequence and data-out sequence	26
Figure 14.	Read data bytes at higher speed (FAST_READ) instruction and data-out sequence	27
Figure 15.	Page program (PP) instruction sequence	29
Figure 16.	Sector erase (SE) instruction sequence	30
Figure 17.	Bulk erase (BE) instruction sequence	31
Figure 18.	Power-up timing	33
Figure 19.	AC measurement I/O waveform	35
Figure 20.	Serial input timing	40
Figure 21.	Write protect setup and hold timing during WRSR when SRWD =1	41
Figure 22.	Hold timing	41
Figure 23.	Output timing	42
Figure 24.	V _{PPH} timing	42
Figure 25.	VDFPN8 (MLP8), 8-lead Very thin Dual Flat Package No lead, 8x6mm, package outline	43
Figure 26.	SO16 wide – 16 lead Plastic Small Outline, 300 mils body width	44

1 Description

The M25P128 is a 128-Mbit (16 Mbit × 8) serial flash memory, with advanced write protection mechanisms and accessed by a high speed SPI-compatible bus, which allows clock frequency operation up to 54 MHz⁽¹⁾.

The memory can be programmed 1 to 256 Bytes at a time, using the page program instruction.

The memory is organized as 64 sectors, each containing 1024 pages. Each page is 256 bytes wide. Thus, the whole memory can be viewed as consisting of 65536 pages, or 16777216 bytes.

An enhanced fast program/erase mode is available to speed up operations in factory environment. The device enters this mode whenever the V_{PPH} voltage is applied to the write protect/enhanced program supply voltage pin (\overline{W}/V_{PP}).

The whole memory can be erased using the bulk erase instruction, or a sector at a time, using the sector erase instruction.

In order to meet environmental requirements, Numonyx offers these devices in Lead-free and RoHS compliant packages.

Note: Important: this datasheet details the functionality of the M25P128 devices, based on the previous 130 nm MLC process or based on the current 65 nm SLC process, identified by the process identification digit 'A' in the device marking and process letter "B" in the part number. The new device is backward compatible with the old one.

Figure 1. Logic diagram

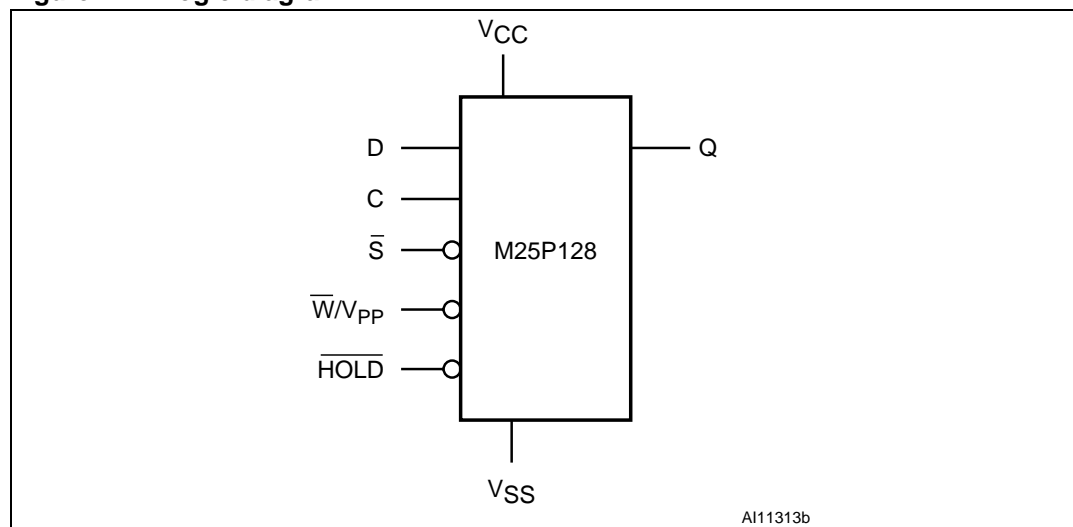

1. 54 MHz operation is available only for 65 nm process technology devices, which are identified by the process identification digit 'A' in the device marking and process letter "B" in the part number.

Table 1. Signal names

Symbol	Description	Direction
C	Serial Clock	Input
D	Serial Data Input	Input
Q	Serial Data Output	Output
\overline{S}	Chip Select	Input
\overline{W}/V_{PP}	Write Protect/Enhanced Program supply voltage	Input
\overline{HOLD}	Hold	Input
V_{CC}	Supply voltage	Supply
V_{SS}	Ground	Ground

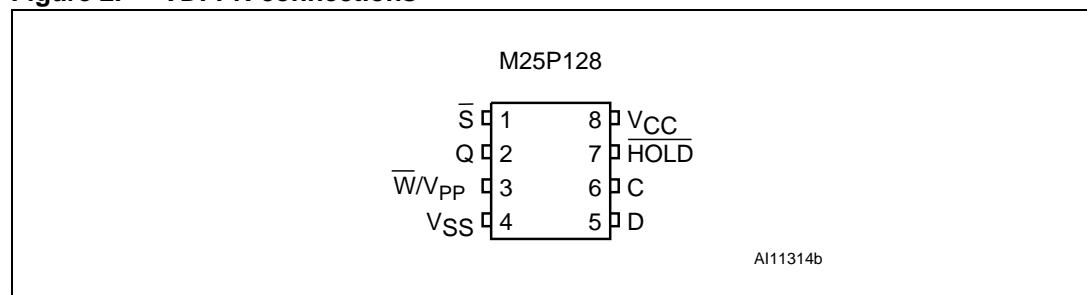
Figure 2. VDFPN connections

1. There is an exposed die paddle on the underside of the MLP8 package. This is pulled, internally, to V_{SS} , and must not be allowed to be connected to any other voltage or signal line on the PCB.
2. See [Package mechanical](#) section for package dimensions, and how to identify pin-1.

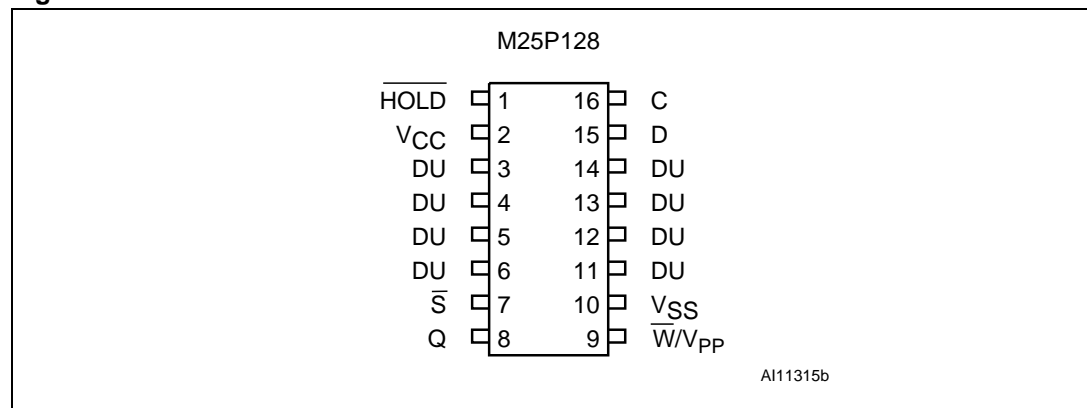
Figure 3. SO connections

1. DU = Don't use
2. See [Package mechanical](#) section for package dimensions, and how to identify pin-1.

2 Signal description

2.1 Serial data output (Q)

This output signal is used to transfer data serially out of the device. Data is shifted out on the falling edge of Serial Clock (C).

2.2 Serial data input (D)

This input signal is used to transfer data serially into the device. It receives instructions, addresses, and the data to be programmed. Values are latched on the rising edge of Serial Clock (C).

2.3 Serial clock (C)

This input signal provides the timing of the serial interface. Instructions, addresses, or data present at Serial Data Input (D) are latched on the rising edge of Serial Clock (C). Data on Serial Data Output (Q) changes after the falling edge of Serial Clock (C).

2.4 Chip Select (\overline{S})

When this input signal is High, the device is deselected and Serial Data Output (Q) is at high impedance. Unless an internal Program, Erase or Write Status Register cycle is in progress, the device will be in the Standby Power mode. Driving Chip Select (\overline{S}) Low selects the device, placing it in the Active Power mode.

After Power-up, a falling edge on Chip Select (\overline{S}) is required prior to the start of any instruction.

2.5 Hold (\overline{HOLD})

The Hold (\overline{HOLD}) signal is used to pause any serial communications with the device without deselecting the device.

During the Hold condition, the Serial Data Output (Q) is high impedance, and Serial Data Input (D) and Serial Clock (C) are Don't Care.

To start the Hold condition, the device must be selected, with Chip Select (\overline{S}) driven Low.

2.6 Write protect/enhanced program supply voltage (\overline{W}/V_{PP})

\overline{W}/V_{PP} is both a control input and a power supply pin. The two functions are selected by the voltage range applied to the pin.

If the \overline{W}/V_{PP} input is kept in a low voltage range (0V to V_{CC}) the pin is seen as a control input. This input signal is used to freeze the size of the area of memory that is protected against program or erase instructions (as specified by the values in the BP2, BP1 and BP0 bits of the Status Register).

If V_{PP} is in the range of V_{PPH} it acts as an additional power supply pin. In this case V_{PP} must be stable until the Program/Erase algorithm is completed.

2.7 V_{CC} supply voltage

V_{CC} is the supply voltage.

2.8 V_{SS} ground

V_{SS} is the reference for the V_{CC} supply voltage.

3 SPI modes

These devices can be driven by a microcontroller with its SPI peripheral running in either of the two following modes:

- CPOL=0, CPHA=0
- CPOL=1, CPHA=1

For these two modes, input data is latched in on the rising edge of Serial Clock (C), and output data is available from the falling edge of Serial Clock (C).

The difference between the two modes, as shown in *Figure 5*, is the clock polarity when the bus master is in Stand-by mode and not transferring data:

- C remains at 0 for (CPOL=0, CPHA=0)
- C remains at 1 for (CPOL=1, CPHA=1)

Figure 4. Bus master and memory devices on the SPI bus

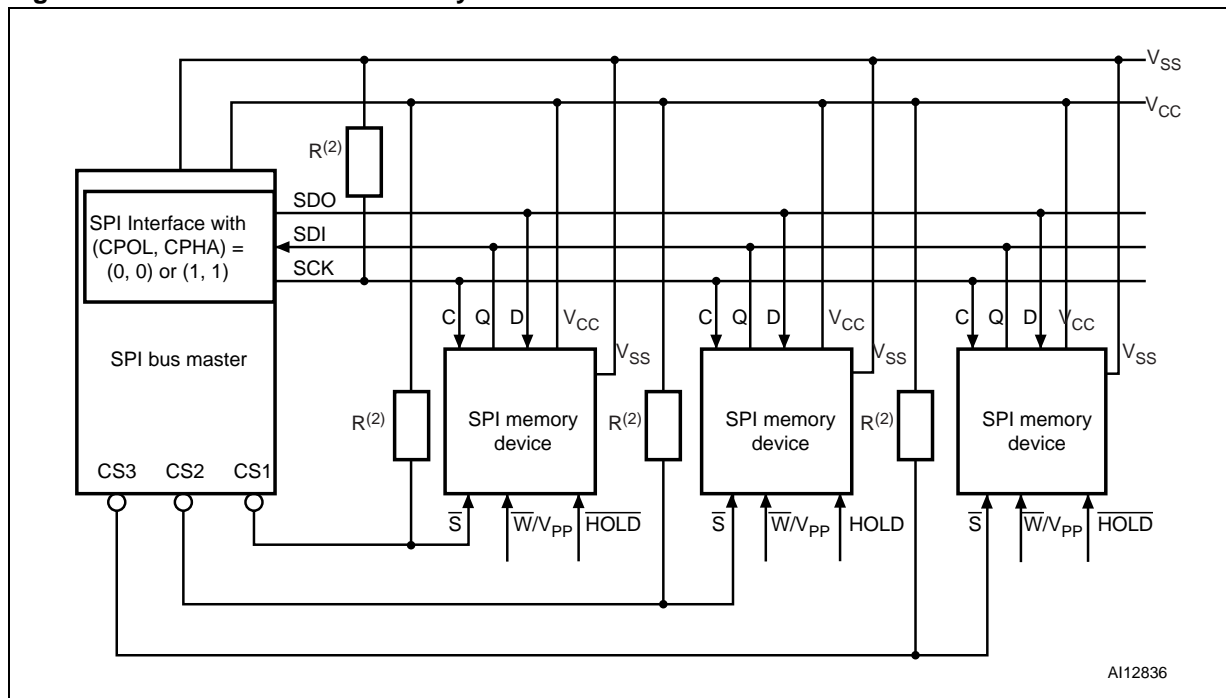

1. The Write Protect (\overline{W}/V_{PP}) and Hold (\overline{HOLD}) signals should be driven, High or Low as appropriate.
2. These pull-up resistors, R, ensure that the memory devices are not selected if the Bus Master leaves the \overline{S} line in the high-impedance state. As the Bus Master may enter a state where all inputs/outputs are in high impedance at the same time (e.g.: when the Bus Master is reset), the clock line (C) must be connected to an external pull-down resistor so that, when all inputs/outputs become high impedance, S is pulled High while C is pulled Low (thus ensuring that S and C do not become High at the same time, and so, that the t_{SCH} requirement is met).

Figure 5. SPI modes supported

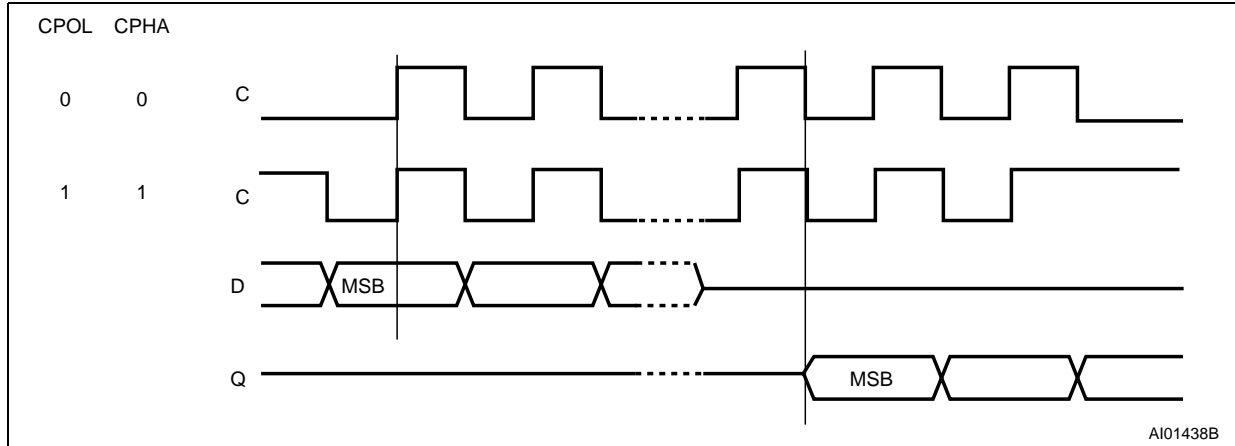

4 Operating features

4.1 Page programming

To program one data byte, two instructions are required: Write Enable (WREN), which is one byte, and a Page Program (PP) sequence, which consists of four bytes plus data. This is followed by the internal Program cycle (of duration t_{PP}).

To spread this overhead, the Page Program (PP) instruction allows up to 256 bytes to be programmed at a time (changing bits from 1 to 0), provided that they lie in consecutive addresses on the same page of memory.

For optimized timings, it is recommended to use the Page Program (PP) instruction to program all consecutive targeted Bytes in a single sequence versus using several Page Program (PP) sequences with each containing only a few Bytes (see [Section 6.8: Page program \(PP\)](#), [Table 15: AC characteristics for 65 nm devices](#), and [Table 17: AC characteristics for 130 nm devices](#)).

4.2 Sector erase and bulk erase

The Page Program (PP) instruction allows bits to be reset from 1 to 0. Before this can be applied, the bytes of memory need to have been erased to all 1s (FFh). This can be achieved either a sector at a time, using the Sector Erase (SE) instruction, or throughout the entire memory, using the Bulk Erase (BE) instruction. This starts an internal Erase cycle (of duration t_{SE} or t_{BE}).

The Erase instruction must be preceded by a Write Enable (WREN) instruction.

4.3 Polling during a write, program or erase cycle

A further improvement in the time to Write Status Register (WRSR), Program (PP) or Erase (SE or BE) can be achieved by not waiting for the worst case delay (t_W , t_{PP} , t_{SE} , or t_{BE}). The Write In Progress (WIP) bit is provided in the Status Register so that the application program can monitor its value, polling it to establish when the previous Write cycle, Program cycle or Erase cycle is complete.

4.4 Fast program/erase mode

The Fast Program/Erase mode is used to speed up programming/erasing. The device enters the Fast Program/Erase mode during the Page Program, Sector Erase or Bulk Erase instruction whenever a voltage equal to V_{PPH} is applied to the \overline{W}/V_{PP} pin.

The use of the Fast Program/Erase mode requires specific operating conditions in addition to the normal ones (V_{CC} must be within the normal operating range):

- the voltage applied to the \overline{W}/V_{PP} pin must be equal to V_{PPH} (see [Table 11](#))
- ambient temperature, T_A must be $25\text{ °C} \pm 10\text{ °C}$,
- the cumulated time during which \overline{W}/V_{PP} is at V_{PPH} should be less than 80 hours

4.5 Active power and standby power modes

When Chip Select (\overline{S}) is Low, the device is selected, and in the Active Power mode.

When Chip Select (\overline{S}) is High, the device is deselected, but could remain in the Active Power mode until all internal cycles have completed (Program, Erase, Write Status Register). The device then goes in to the Standby Power mode. The device consumption drops to I_{CC1} .

4.6 Status register

The Status Register contains a number of status and control bits that can be read or set (as appropriate) by specific instructions. See [Section 6.4: Read status register \(RDSR\)](#) for a detailed description of the Status Register bits.

4.7 Protection modes

The environments where non-volatile memory devices are used can be very noisy. No SPI device can operate correctly in the presence of excessive noise. To help combat this, the M25P128 features the following data protection mechanisms:

- Power On Reset and an internal timer (t_{PUW}) can provide protection against inadvertent changes while the power supply is outside the operating specification.
- Program, Erase and Write Status Register instructions are checked that they consist of a number of clock pulses that is a multiple of eight, before they are accepted for execution.
- All instructions that modify data must be preceded by a Write Enable (WREN) instruction to set the Write Enable Latch (WEL) bit. This bit is returned to its reset state by the following events:
 - Power-up
 - Write Disable (WRDI) instruction completion
 - Write Status Register (WRSR) instruction completion
 - Page Program (PP) instruction completion
 - Sector Erase (SE) instruction completion
 - Bulk Erase (BE) instruction completion
- The Block Protect (BP2, BP1, BP0) bits allow part of the memory to be configured as read-only. This is the Software Protected Mode (SPM).
- The Write Protect (\overline{W}/V_{PP}) signal allows the Block Protect (BP2, BP1, BP0) bits and Status Register Write Disable (SRWD) bit to be protected. This is the Hardware Protected Mode (HPM).

Table 2. Protected area sizes

Status Register content			Memory content	
BP2 Bit	BP1 Bit	BP0 Bit	Protected area	Unprotected area
0	0	0	none	All Sectors (Sectors 0 to 63) ⁽¹⁾
0	0	1	Upper 64th (1 Sector, 2Mb)	Sectors 0 to 62
0	1	0	Upper 32nd (2 Sectors, 4Mb)	Sectors 0 to 61
0	1	1	Upper 16nd (4 Sectors, 8Mb)	Sectors 0 to 59
1	0	0	Upper 8nd (8 Sectors, 16Mb)	Sectors 0 to 55
1	0	1	Upper Quarter (16 Sectors, 32Mb)	Lower 3 Quarters (Sectors 0 to 47)
1	1	0	Upper Half (32 Sectors, 64Mb)	Lower Half (Sectors 0 to 31)
1	1	1	All sectors (64 Sectors, 128Mb)	none

1. The device is ready to accept a Bulk Erase instruction if, and only if, all Block Protect (BP2, BP1, BP0) are 0.

4.8 Hold condition

The Hold ($\overline{\text{HOLD}}$) signal is used to pause any serial communications with the device without resetting the clocking sequence. However, taking this signal Low does not terminate any Write Status Register, Program or Erase cycle that is currently in progress.

To enter the Hold condition, the device must be selected, with Chip Select ($\overline{\text{S}}$) Low.

The Hold condition starts on the falling edge of the Hold ($\overline{\text{HOLD}}$) signal, provided that this coincides with Serial Clock (C) being Low (as shown in [Figure 6](#)).

The Hold condition ends on the rising edge of the Hold ($\overline{\text{HOLD}}$) signal, provided that this coincides with Serial Clock (C) being Low.

If the falling edge does not coincide with Serial Clock (C) being Low, the Hold condition starts after Serial Clock (C) next goes Low. Similarly, if the rising edge does not coincide with Serial Clock (C) being Low, the Hold condition ends after Serial Clock (C) next goes Low. (This is shown in [Figure 6](#)).

During the Hold condition, the Serial Data Output (Q) is high impedance, and Serial Data Input (D) and Serial Clock (C) are Don't Care.

Normally, the device is kept selected, with Chip Select ($\overline{\text{S}}$) driven Low, for the whole duration of the Hold condition. This is to ensure that the state of the internal logic remains unchanged from the moment of entering the Hold condition.

If Chip Select ($\overline{\text{S}}$) goes High while the device is in the Hold condition, this has the effect of resetting the internal logic of the device. To restart communication with the device, it is necessary to drive Hold ($\overline{\text{HOLD}}$) High, and then to drive Chip Select ($\overline{\text{S}}$) Low. This prevents the device from going back to the Hold condition.

Figure 6. Hold condition activation

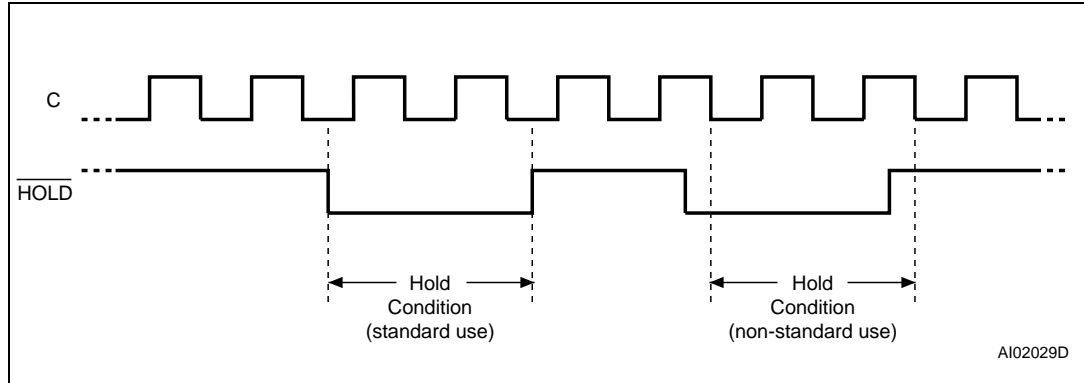

5 Memory organization

The memory is organized as:

- 16777216 bytes (8 bits each)
- 64 sectors (2 Mbits, 262144 bytes each)
- 65536 pages (256 bytes each).

Each page can be individually programmed (bits are programmed from 1 to 0). The device is Sector or Bulk Erasable (bits are erased from 0 to 1) but not Page Erasable.

Figure 7. Block diagram

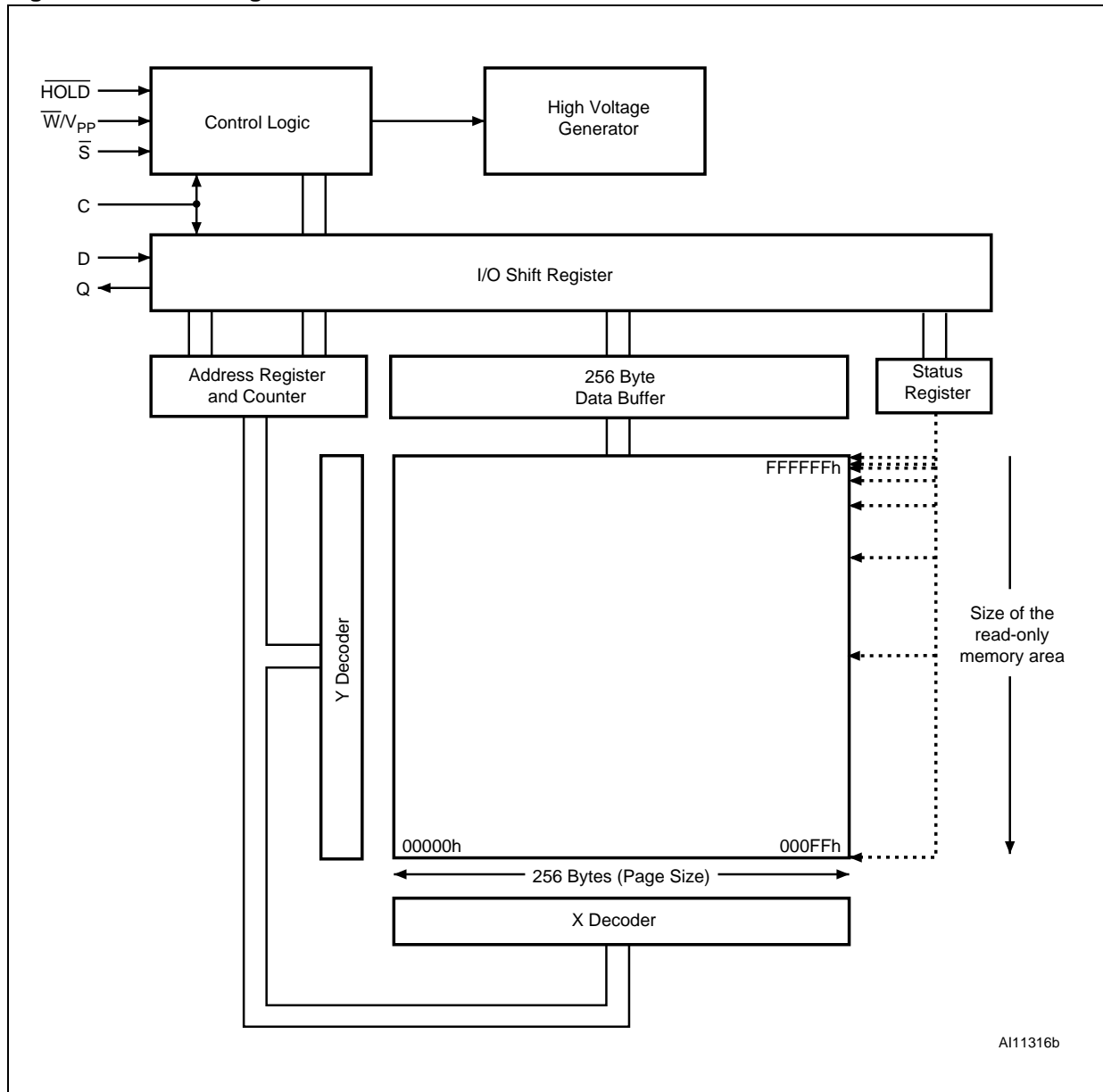

Table 3. Memory organization

Sector	Address Range	
63	FC0000h	FFFFFFh
62	F80000h	FBFFFFh
61	F40000h	F7FFFFh
60	F00000h	F3FFFFh
59	EC0000h	EFFFFFh
58	E80000h	EBFFFFh
57	E40000h	E7FFFFh
56	E00000h	E3FFFFh
55	DC0000h	DFFFFFFh
54	D80000h	DBFFFFh
53	D40000h	D7FFFFh
52	D00000h	D3FFFFh
51	CC0000h	CFFFFFFh
50	C80000h	CBFFFFh
49	C40000h	C7FFFFh
48	C00000h	C3FFFFh
47	BC0000h	BFFFFFFh
46	B80000h	BBFFFFh
45	B40000h	B7FFFFh
44	B00000h	B3FFFFh
43	AC0000h	AFFFFFFh
42	A80000h	ABFFFFh
41	A40000h	A7FFFFh
40	A00000h	A3FFFFh
39	9C0000h	9FFFFFFh
38	980000h	9BFFFFh
37	940000h	97FFFFh
36	900000h	93FFFFh
35	8C0000h	8FFFFFFh
34	880000h	8BFFFFh
33	840000h	87FFFFh
32	800000h	83FFFFh
31	7C0000h	7FFFFFFh
30	780000h	7BFFFFh
29	740000h	77FFFFh

Table 3. Memory organization (continued)

Sector	Address Range	
28	70000h	73FFFFh
27	6C000h	6FFFFh
26	68000h	6BFFFFh
25	64000h	67FFFFh
24	60000h	63FFFFh
23	5C000h	5FFFFh
22	58000h	5BFFFFh
21	54000h	57FFFFh
20	50000h	53FFFFh
19	4C000h	4FFFFh
18	48000h	4BFFFFh
17	44000h	47FFFFh
16	40000h	43FFFFh
15	3C000h	3FFFFh
14	38000h	3BFFFFh
13	34000h	37FFFFh
12	30000h	33FFFFh
11	2C000h	2FFFFh
10	28000h	2BFFFFh
9	24000h	27FFFFh
8	20000h	23FFFFh
7	1C000h	1FFFFh
6	18000h	1BFFFFh
5	14000h	17FFFFh
4	10000h	13FFFFh
3	0C000h	0FFFFh
2	08000h	0BFFFFh
1	04000h	07FFFFh
0	00000h	03FFFFh

6 Instructions

All instructions, addresses and data are shifted in and out of the device, most significant bit first.

Serial Data Input (D) is sampled on the first rising edge of Serial Clock (C) after Chip Select (\bar{S}) is driven Low. Then, the one-byte instruction code must be shifted in to the device, most significant bit first, on Serial Data Input (D), each bit being latched on the rising edges of Serial Clock (C).

The instruction set is listed in [Table 4](#).

Every instruction sequence starts with a one-byte instruction code. Depending on the instruction, this might be followed by address bytes, or by data bytes, or by both or none.

In the case of a Read Data Bytes (READ), Read Data Bytes at Higher Speed (Fast_Read), Read Status Register (RDSR) or Read Identification (RDID) instruction, the shifted-in instruction sequence is followed by a data-out sequence. Chip Select (\bar{S}) can be driven High after any bit of the data-out sequence is being shifted out.

In the case of a Page Program (PP), Sector Erase (SE), Bulk Erase (BE), Write Status Register (WRSR), Write Enable (WREN) or Write Disable (WRDI), Chip Select (\bar{S}) must be driven High exactly at a byte boundary, otherwise the instruction is rejected, and is not executed. That is, Chip Select (\bar{S}) must driven High when the number of clock pulses after Chip Select (\bar{S}) being driven Low is an exact multiple of eight.

All attempts to access the memory array during a Write Status Register cycle, Program cycle or Erase cycle are ignored, and the internal Write Status Register cycle, Program cycle or Erase cycle continues unaffected.

Table 4. Instruction set

Instruction	Description	One-byte Instruction Code	Address Bytes	Dummy Bytes	Data Bytes	
WREN	Write Enable	0000 0110	06h	0	0	
WRDI	Write Disable	0000 0100	04h	0	0	
RDID	Read Identification	1001 1111	9Fh	0	0	1 to 3
RDSR	Read Status Register	0000 0101	05h	0	0	1 to ∞
WRSR	Write Status Register	0000 0001	01h	0	0	1
READ	Read Data Bytes	0000 0011	03h	3	0	1 to ∞
FAST_READ	Read Data Bytes at Higher Speed	0000 1011	0Bh	3	1	1 to ∞
PP	Page Program	0000 0010	02h	3	0	1 to 256
SE	Sector Erase	1101 1000	D8h	3	0	0
BE	Bulk Erase	1100 0111	C7h	0	0	0

6.1 Write enable (WREN)

The Write Enable (WREN) instruction (*Figure 8*) sets the Write Enable Latch (WEL) bit.

The Write Enable Latch (WEL) bit must be set prior to every Page Program (PP), Sector Erase (SE), Bulk Erase (BE) and Write Status Register (WRSR) instruction.

The Write Enable (WREN) instruction is entered by driving Chip Select (\bar{S}) Low, sending the instruction code, and then driving Chip Select (\bar{S}) High.

Figure 8. Write enable (WREN) instruction sequence

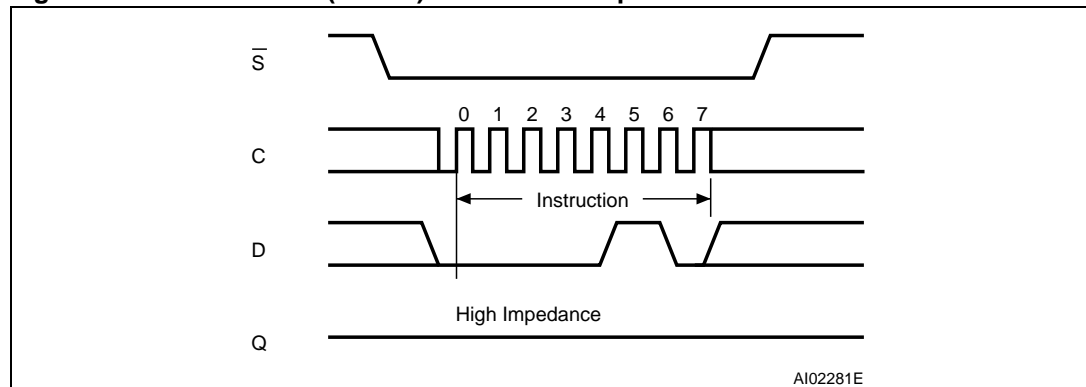

6.2 Write disable (WRDI)

The Write Disable (WRDI) instruction (*Figure 9*) resets the Write Enable Latch (WEL) bit.

The Write Disable (WRDI) instruction is entered by driving Chip Select (\bar{S}) Low, sending the instruction code, and then driving Chip Select (\bar{S}) High.

The Write Enable Latch (WEL) bit is reset under the following conditions:

- Power-up
- Write Disable (WRDI) instruction completion
- Write Status Register (WRSR) instruction completion
- Page Program (PP) instruction completion
- Sector Erase (SE) instruction completion
- Bulk Erase (BE) instruction completion

Figure 9. Write disable (WRDI) instruction sequence

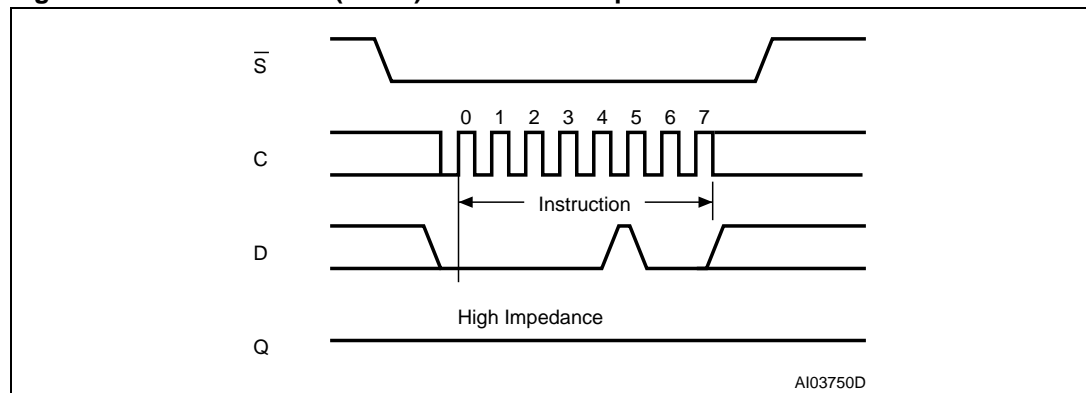

6.3 Read identification (RDID)

The Read Identification (RDID) instruction allows the 8-bit manufacturer identification to be read, followed by two bytes of device identification. The manufacturer identification is assigned by JEDEC, and has the value 20h for Numonyx. The device identification is assigned by the device manufacturer, and indicates the memory type in the first byte (20h), and the memory capacity of the device in the second byte (18h).

Any Read Identification (RDID) instruction while an Erase or Program cycle is in progress, is not decoded, and has no effect on the cycle that is in progress.

The device is first selected by driving Chip Select (\bar{S}) Low. Then, the 8-bit instruction code for the instruction is shifted in. This is followed by the 24-bit device identification, stored in the memory, being shifted out on Serial Data Output (Q), each bit being shifted out during the falling edge of Serial Clock (C).

The instruction sequence is shown in *Figure 10*.

The Read Identification (RDID) instruction is terminated by driving Chip Select (\bar{S}) High at any time during data output.

When Chip Select (\bar{S}) is driven High, the device is put in the Standby Power mode. Once in the Standby Power mode, the device waits to be selected, so that it can receive, decode and execute instructions.

Table 5. Read identification (RDID) data-out sequence

Manufacturer Identification	Device Identification	
	Memory Type	Memory Capacity
20h	20h	18h

Figure 10. Read identification (RDID) instruction sequence and data-out sequence

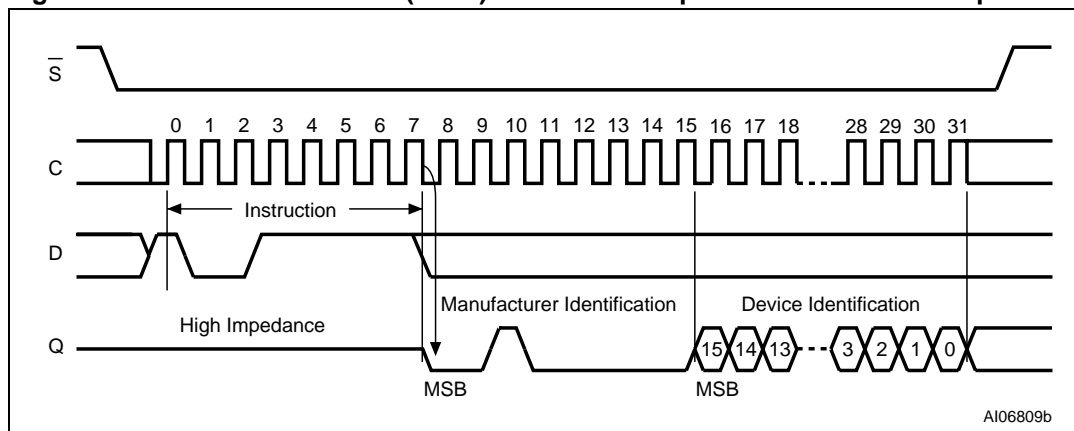

6.4 Read status register (RDSR)

The Read Status Register (RDSR) instruction allows the Status Register to be read. The Status Register may be read at any time, even while a Program, Erase or Write Status Register cycle is in progress. When one of these cycles is in progress, it is recommended to check the Write In Progress (WIP) bit before sending a new instruction to the device. It is also possible to read the Status Register continuously, as shown in [Figure 11](#).

Table 6. Status register format

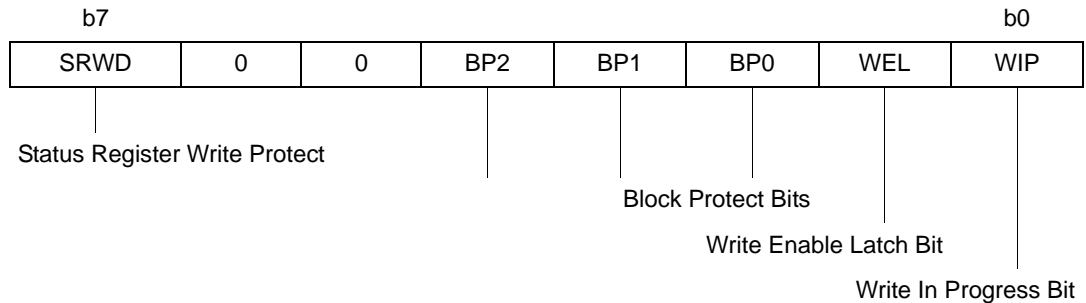

The status and control bits of the Status Register are as follows:

6.4.1 WIP bit

The Write In Progress (WIP) bit indicates whether the memory is busy with a Write Status Register, Program or Erase cycle. When set to 1, such a cycle is in progress, when reset to 0 no such cycle is in progress.

6.4.2 WEL bit

The Write Enable Latch (WEL) bit indicates the status of the internal Write Enable Latch. When set to 1 the internal Write Enable Latch is set, when set to 0 the internal Write Enable Latch is reset and no Write Status Register, Program or Erase instruction is accepted.

6.4.3 BP2, BP1, BP0 bits

The Block Protect (BP2, BP1, BP0) bits are non-volatile. They define the size of the area to be software protected against Program and Erase instructions. These bits are written with the Write Status Register (WRSR) instruction. When one or more of the Block Protect (BP2, BP1, BP0) bits is set to 1, the relevant memory area (as defined in [Table 2](#)) becomes protected against Page Program (PP) and Sector Erase (SE) instructions. The Block Protect (BP2, BP1, BP0) bits can be written provided that the Hardware Protected mode has not been set. The Bulk Erase (BE) instruction is executed if, and only if, all Block Protect (BP2, BP1, BP0) bits are 0.

6.4.4 SRWD bit

The Status Register Write Disable (SRWD) bit is operated in conjunction with the Write Protect ($\overline{W/V_{PP}}$) signal. The Status Register Write Disable (SRWD) bit and Write Protect ($\overline{W/V_{PP}}$) signal allow the device to be put in the Hardware Protected mode (when the Status Register Write Disable (SRWD) bit is set to 1, and Write Protect ($\overline{W/V_{PP}}$) is driven Low). In this mode, the non-volatile bits of the Status Register (SRWD, BP2, BP1, BP0) become

read-only bits and the Write Status Register (WRSR) instruction is no longer accepted for execution.

Figure 11. Read status register (RDSR) instruction sequence and data-out sequence

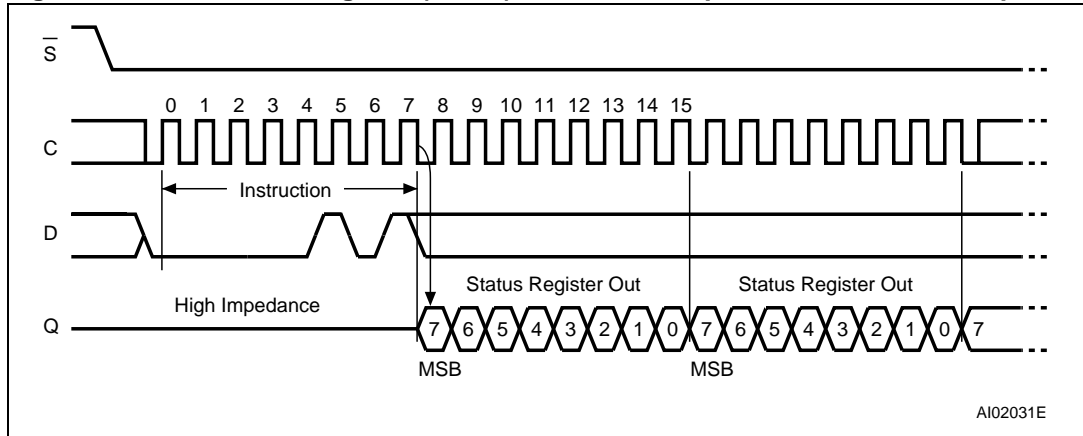

6.5 Write status register (WRSR)

The Write Status Register (WRSR) instruction allows new values to be written to the Status Register. Before it can be accepted, a Write Enable (WREN) instruction must previously have been executed. After the Write Enable (WREN) instruction has been decoded and executed, the device sets the Write Enable Latch (WEL).

The Write Status Register (WRSR) instruction is entered by driving Chip Select (\bar{S}) Low, followed by the instruction code and the data byte on Serial Data Input (D).

The instruction sequence is shown in [Figure 12](#).

The Write Status Register (WRSR) instruction has no effect on b6, b5, b1 and b0 of the Status Register. b6 and b5 are always read as 0.

Chip Select (\bar{S}) must be driven High after the eighth bit of the data byte has been latched in. If not, the Write Status Register (WRSR) instruction is not executed. As soon as Chip Select (\bar{S}) is driven High, the self-timed Write Status Register cycle (whose duration is t_W) is initiated. While the Write Status Register cycle is in progress, the Status Register may still be read to check the value of the Write In Progress (WIP) bit. The Write In Progress (WIP) bit is 1 during the self-timed Write Status Register cycle, and is 0 when it is completed. When the cycle is completed, the Write Enable Latch (WEL) is reset.

The Write Status Register (WRSR) instruction allows the user to change the values of the Block Protect (BP2, BP1, BP0) bits, to define the size of the area that is to be treated as read-only, as defined in [Table 2](#). The Write Status Register (WRSR) instruction also allows the user to set or reset the Status Register Write Disable (SRWD) bit in accordance with the Write Protect (\bar{W}/V_{PP}) signal. The Status Register Write Disable (SRWD) bit and Write Protect (\bar{W}/V_{PP}) signal allow the device to be put in the Hardware Protected Mode (HPM). The Write Status Register (WRSR) instruction is not executed once the Hardware Protected Mode (HPM) is entered.

Table 7. Protection modes

\bar{W}/V_{PP} Signal	SRWD Bit	Mode	Write Protection of the Status Register	Memory Content	
				Protected Area ⁽¹⁾	Unprotected Area ⁽¹⁾
1	0	Software Protected (SPM)	Status Register is Writable (if the WREN instruction has set the WEL bit)	Protected against Page Program, Sector Erase and Bulk Erase	Ready to accept Page Program and Sector Erase instructions
0	0		The values in the SRWD, BP2, BP1 and BP0 bits can be changed		
1	1				
0	1	Hardware Protected (HPM)	Status Register is Hardware write protected The values in the SRWD, BP2, BP1 and BP0 bits cannot be changed	Protected against Page Program, Sector Erase and Bulk Erase	Ready to accept Page Program and Sector Erase instructions

1. As defined by the values in the Block Protect (BP2, BP1, BP0) bits of the Status Register, as shown in [Table 2: Protected area sizes](#).

The protection features of the device are summarized in [Table 7](#)

When the Status Register Write Disable (SRWD) bit of the Status Register is 0 (its initial delivery state), it is possible to write to the Status Register provided that the Write Enable

Latch (WEL) bit has previously been set by a Write Enable (WREN) instruction, regardless of the whether Write Protect (\overline{W}/V_{PP}) is driven High or Low.

When the Status Register Write Disable (SRWD) bit of the Status Register is set to 1, two cases need to be considered, depending on the state of Write Protect (\overline{W}/V_{PP}):

- If Write Protect (\overline{W}/V_{PP}) is driven High, it is possible to write to the Status Register provided that the Write Enable Latch (WEL) bit has previously been set by a Write Enable (WREN) instruction.
- If Write Protect (\overline{W}/V_{PP}) is driven Low, it is *not* possible to write to the Status Register *even* if the Write Enable Latch (WEL) bit has previously been set by a Write Enable (WREN) instruction. (Attempts to write to the Status Register are rejected, and are not accepted for execution). As a consequence, all the data bytes in the memory area that are software protected (SPM) by the Block Protect (BP2, BP1, BP0) bits of the Status Register, are also hardware protected against data modification.

Regardless of the order of the two events, the Hardware Protected Mode (HPM) can be entered:

- by setting the Status Register Write Disable (SRWD) bit after driving Write Protect (\overline{W}/V_{PP}) Low
- or by driving Write Protect (\overline{W}/V_{PP}) Low after setting the Status Register Write Disable (SRWD) bit.

The only way to exit the Hardware Protected Mode (HPM) once entered is to pull Write Protect (\overline{W}/V_{PP}) High.

If Write Protect (\overline{W}/V_{PP}) is permanently tied High, the Hardware Protected Mode (HPM) can never be activated, and only the Software Protected Mode (SPM), using the Block Protect (BP2, BP1, BP0) bits of the Status Register, can be used.

Figure 12. Write status register (WRSR) instruction sequence

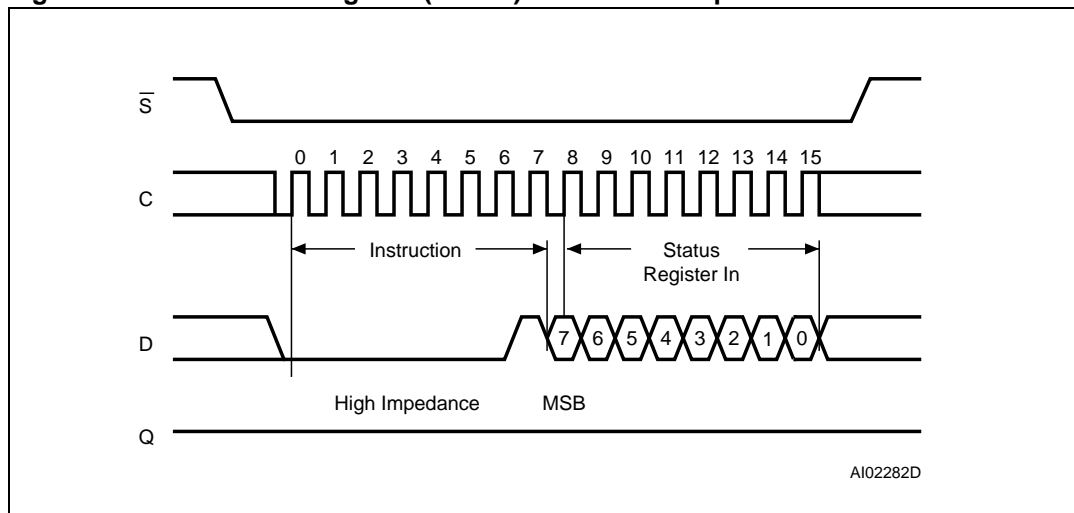

6.6 Read data bytes (READ)

The device is first selected by driving Chip Select (\overline{S}) Low. The instruction code for the Read Data Bytes (READ) instruction is followed by a 3-byte address (A23-A0), each bit being latched-in during the rising edge of Serial Clock (C). Then the memory contents, at that address, is shifted out on Serial Data Output (Q), each bit being shifted out, at a maximum frequency f_R , during the falling edge of Serial Clock (C).

The instruction sequence is shown in *Figure 13*.

The first byte addressed can be at any location. The address is automatically incremented to the next higher address after each byte of data is shifted out. The whole memory can, therefore, be read with a single Read Data Bytes (READ) instruction. When the highest address is reached, the address counter rolls over to 000000h, allowing the read sequence to be continued indefinitely.

The Read Data Bytes (READ) instruction is terminated by driving Chip Select (\overline{S}) High. Chip Select (\overline{S}) can be driven High at any time during data output. Any Read Data Bytes (READ) instruction, while an Erase, Program or Write cycle is in progress, is rejected without having any effects on the cycle that is in progress.

Figure 13. Read data bytes (READ) instruction sequence and data-out sequence

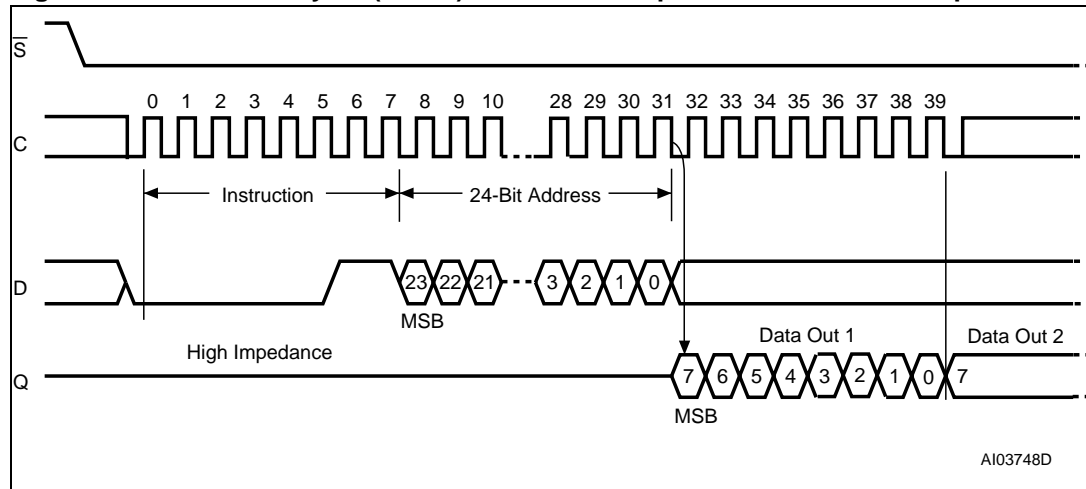

6.7 Read data bytes at higher speed (FAST_READ)

The device is first selected by driving Chip Select (\bar{S}) Low. The instruction code for the Read Data Bytes at Higher Speed (FAST_READ) instruction is followed by a 3-byte address (A23-A0) and a dummy byte, each bit being latched-in during the rising edge of Serial Clock (C). Then the memory contents, at that address, is shifted out on Serial Data Output (Q), each bit being shifted out, at a maximum frequency f_C , during the falling edge of Serial Clock (C).

The instruction sequence is shown in [Figure 14](#).

The first byte addressed can be at any location. The address is automatically incremented to the next higher address after each byte of data is shifted out. The whole memory can, therefore, be read with a single Read Data Bytes at Higher Speed (FAST_READ) instruction. When the highest address is reached, the address counter rolls over to 000000h, allowing the read sequence to be continued indefinitely.

The Read Data Bytes at Higher Speed (FAST_READ) instruction is terminated by driving Chip Select (\bar{S}) High. Chip Select (\bar{S}) can be driven High at any time during data output. Any Read Data Bytes at Higher Speed (FAST_READ) instruction, while an Erase, Program or Write cycle is in progress, is rejected without having any effects on the cycle that is in progress.

Figure 14. Read data bytes at higher speed (FAST_READ) instruction and data-out sequence

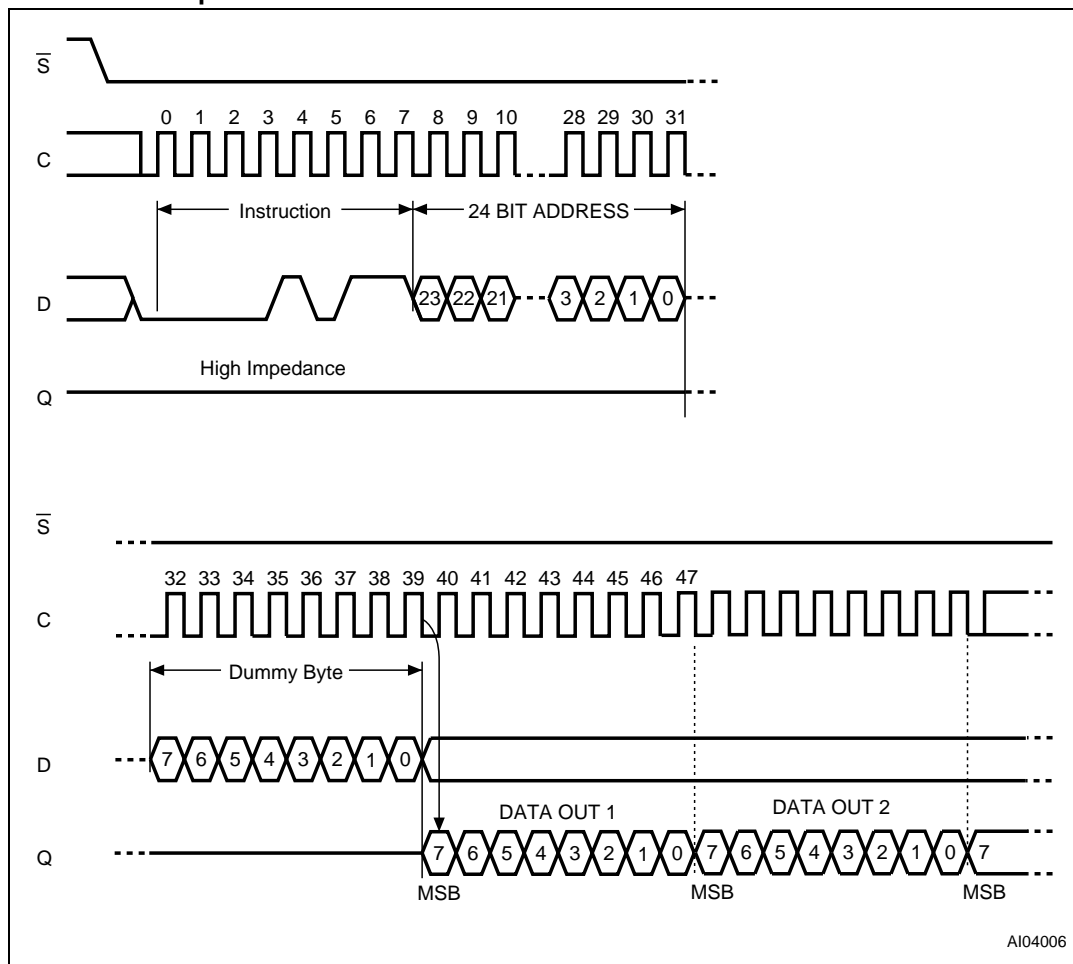

6.8 Page program (PP)

The Page Program (PP) instruction allows bytes to be programmed in the memory (changing bits from 1 to 0). Before it can be accepted, a Write Enable (WREN) instruction must previously have been executed. After the Write Enable (WREN) instruction has been decoded, the device sets the Write Enable Latch (WEL).

The Page Program (PP) instruction is entered by driving Chip Select (\bar{S}) Low, followed by the instruction code, three address bytes and at least one data byte on Serial Data Input (D). If the 8 least significant address bits (A7-A0) are not all zero, all transmitted data that goes beyond the end of the current page are programmed from the start address of the same page (from the address whose 8 least significant bits (A7-A0) are all zero). Chip Select (\bar{S}) must be driven Low for the entire duration of the sequence. The instruction sequence is shown in [Figure 15](#).

If more than 256 bytes are sent to the device, previously latched data are discarded and the last 256 data bytes are guaranteed to be programmed correctly within the same page. If less than 256 Data bytes are sent to device, they are correctly programmed at the requested addresses without having any effects on the other bytes of the same page.

For optimized timings, it is recommended to use the Page Program (PP) instruction to program all consecutive targeted Bytes in a single sequence versus using several Page Program (PP) sequences with each containing only a few Bytes (see [Table 15: AC characteristics for 65 nm devices](#) and [Table 17: AC characteristics for 130 nm devices](#)).

Chip Select (\bar{S}) must be driven High after the eighth bit of the last data byte has been latched in, otherwise the Page Program (PP) instruction is not executed.

As soon as Chip Select (\bar{S}) is driven High, the self-timed Page Program cycle (whose duration is t_{pp}) is initiated. While the Page Program cycle is in progress, the Status Register may be read to check the value of the Write In Progress (WIP) bit. The Write In Progress (WIP) bit is 1 during the self-timed Page Program cycle, and is 0 when it is completed. At some unspecified time before the cycle is completed, the Write Enable Latch (WEL) bit is reset.

A Page Program (PP) instruction applied to a page which is protected by the Block Protect (BP2, BP1, BP0) bits (see [Table 2](#) and [Table 3](#)) is not executed.

Figure 15. Page program (PP) instruction sequence

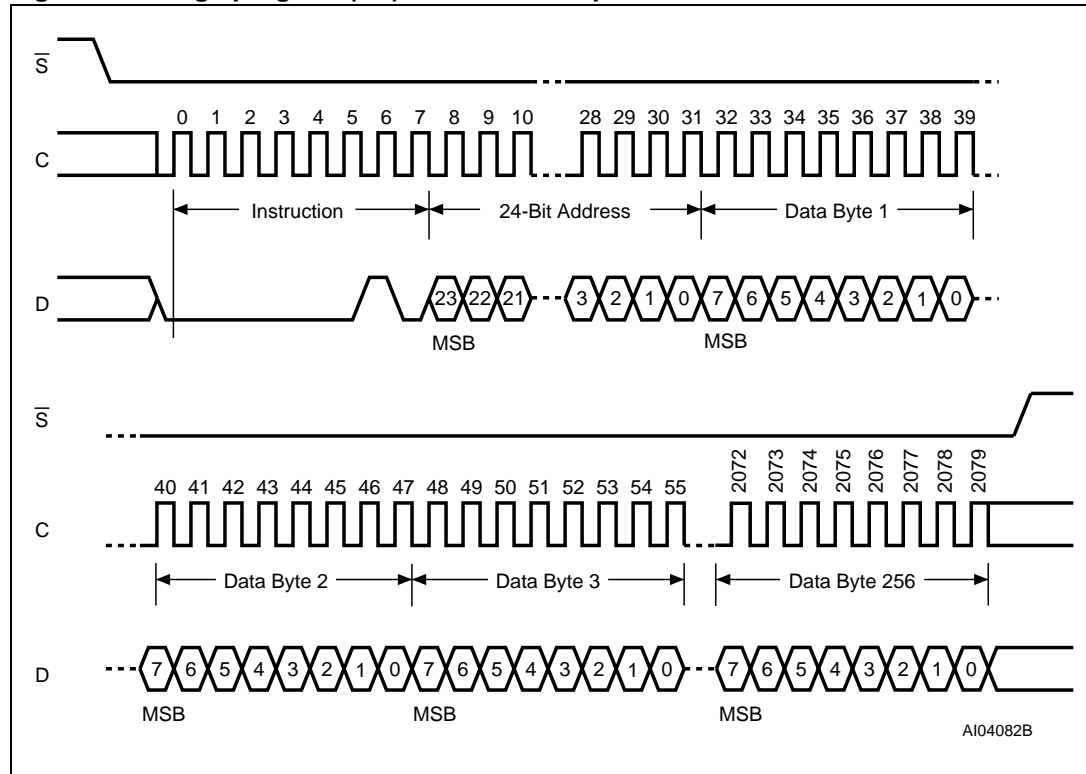

6.9 Sector erase (SE)

The Sector Erase (SE) instruction sets to 1 (FFh) all bits inside the chosen sector. Before it can be accepted, a Write Enable (WREN) instruction must previously have been executed. After the Write Enable (WREN) instruction has been decoded, the device sets the Write Enable Latch (WEL).

The Sector Erase (SE) instruction is entered by driving Chip Select (\bar{S}) Low, followed by the instruction code, and three address bytes on Serial Data Input (D). Any address inside the Sector (see [Table 3](#)) is a valid address for the Sector Erase (SE) instruction. Chip Select (\bar{S}) must be driven Low for the entire duration of the sequence.

The instruction sequence is shown in [Figure 16](#).

Chip Select (\bar{S}) must be driven High after the eighth bit of the last address byte has been latched in, otherwise the Sector Erase (SE) instruction is not executed. As soon as Chip Select (\bar{S}) is driven High, the self-timed Sector Erase cycle (whose duration is t_{SE}) is initiated. While the Sector Erase cycle is in progress, the Status Register may be read to check the value of the Write In Progress (WIP) bit. The Write In Progress (WIP) bit is 1 during the self-timed Sector Erase cycle, and is 0 when it is completed. At some unspecified time before the cycle is completed, the Write Enable Latch (WEL) bit is reset.

A Sector Erase (SE) instruction applied to a page which is protected by the Block Protect (BP2, BP1, BP0) bits (see [Table 2](#) and [Table 3](#)) is not executed.

Figure 16. Sector erase (SE) instruction sequence

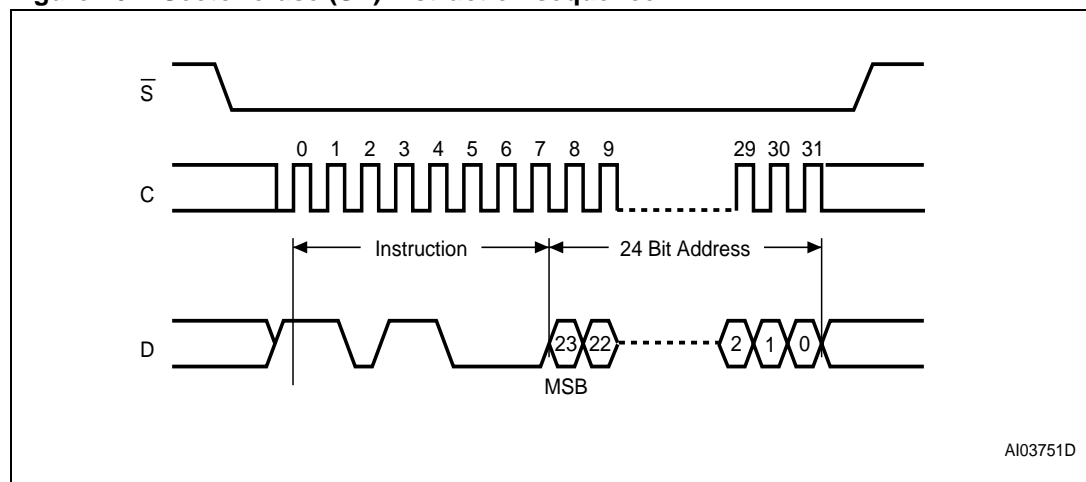

6.10 Bulk erase (BE)

The Bulk Erase (BE) instruction sets all bits to 1 (FFh). Before it can be accepted, a Write Enable (WREN) instruction must previously have been executed. After the Write Enable (WREN) instruction has been decoded, the device sets the Write Enable Latch (WEL).

The Bulk Erase (BE) instruction is entered by driving Chip Select (\bar{S}) Low, followed by the instruction code on Serial Data Input (D). Chip Select (\bar{S}) must be driven Low for the entire duration of the sequence.

The instruction sequence is shown in [Figure 17](#).

Chip Select (\bar{S}) must be driven High after the eighth bit of the instruction code has been latched in, otherwise the Bulk Erase instruction is not executed. As soon as Chip Select (\bar{S}) is driven High, the self-timed Bulk Erase cycle (whose duration is t_{BE}) is initiated. While the Bulk Erase cycle is in progress, the Status Register may be read to check the value of the Write In Progress (WIP) bit. The Write In Progress (WIP) bit is 1 during the self-timed Bulk Erase cycle, and is 0 when it is completed. At some unspecified time before the cycle is completed, the Write Enable Latch (WEL) bit is reset.

The Bulk Erase (BE) instruction is executed only if all Block Protect (BP2, BP1, BP0) bits are 0. The Bulk Erase (BE) instruction is ignored if one, or more, sectors are protected.

Figure 17. Bulk erase (BE) instruction sequence

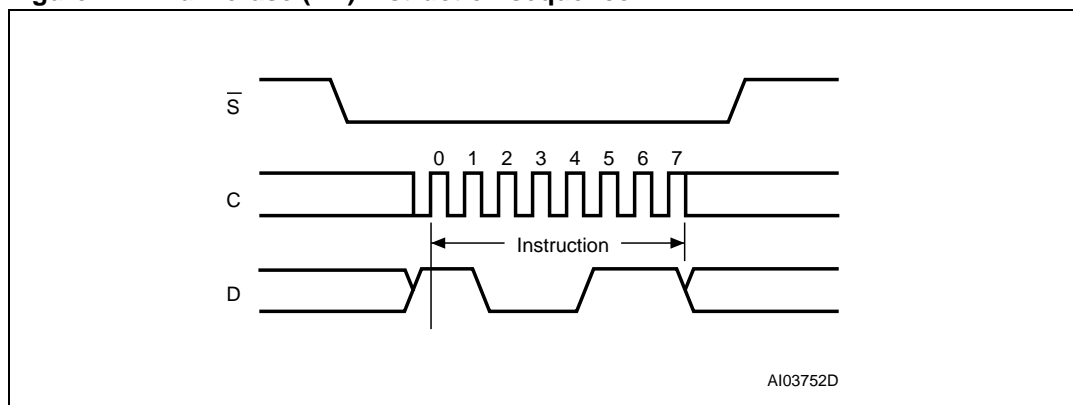

7 Power-up and power-down

At Power-up and Power-down, the device must not be selected (that is Chip Select (\overline{S}) must follow the voltage applied on V_{CC}) until V_{CC} reaches the correct value:

- $V_{CC}(\text{min})$ at Power-up, and then for a further delay of t_{VSL}
- V_{SS} at Power-down

Usually a simple pull-up resistor on Chip Select (\overline{S}) can be used to ensure safe and proper Power-up and Power-down.

To avoid data corruption and inadvertent write operations during Power-up, a Power On Reset (POR) circuit is included. The logic inside the device is held reset while V_{CC} is less than the Power On Reset (POR) threshold voltage, V_{WI} – all operations are disabled, and the device does not respond to any instruction.

Moreover, the device ignores all Write Enable (WREN), Page Program (PP), Sector Erase (SE), Bulk Erase (BE) and Write Status Register (WRSR) instructions until a time delay of t_{PUW} has elapsed after the moment that V_{CC} rises above the V_{WI} threshold. However, the correct operation of the device is not guaranteed if, by this time, V_{CC} is still below $V_{CC}(\text{min})$. No Write Status Register, Program or Erase instructions should be sent until the later of:

- t_{PUW} after V_{CC} passed the V_{WI} threshold
- t_{VSL} after V_{CC} passed the $V_{CC}(\text{min})$ level

These values are specified in [Table 8](#).

If the delay, t_{VSL} , has elapsed, after V_{CC} has risen above $V_{CC}(\text{min})$, the device can be selected for READ instructions even if the t_{PUW} delay is not yet fully elapsed.

At Power-up, the device is in the following state:

- The device is in the Standby Power mode
- The Write Enable Latch (WEL) bit is reset.

Normal precautions must be taken for supply rail decoupling, to stabilize the V_{CC} supply. Each device in a system should have the V_{CC} rail decoupled by a suitable capacitor close to the package pins (generally, this capacitor is of the order of 0.1 μ F).

At Power-down, when V_{CC} drops from the operating voltage, to below the Power On Reset (POR) threshold voltage, V_{WI} , all operations are disabled and the device does not respond to any instruction. (The designer needs to be aware that if a Power-down occurs while a Write, Program or Erase cycle is in progress, some data corruption can result.)

Power up sequencing for Fast program/erase mode: V_{CC} should attain V_{CCMIN} before V_{PPH} is applied.

Figure 18. Power-up timing

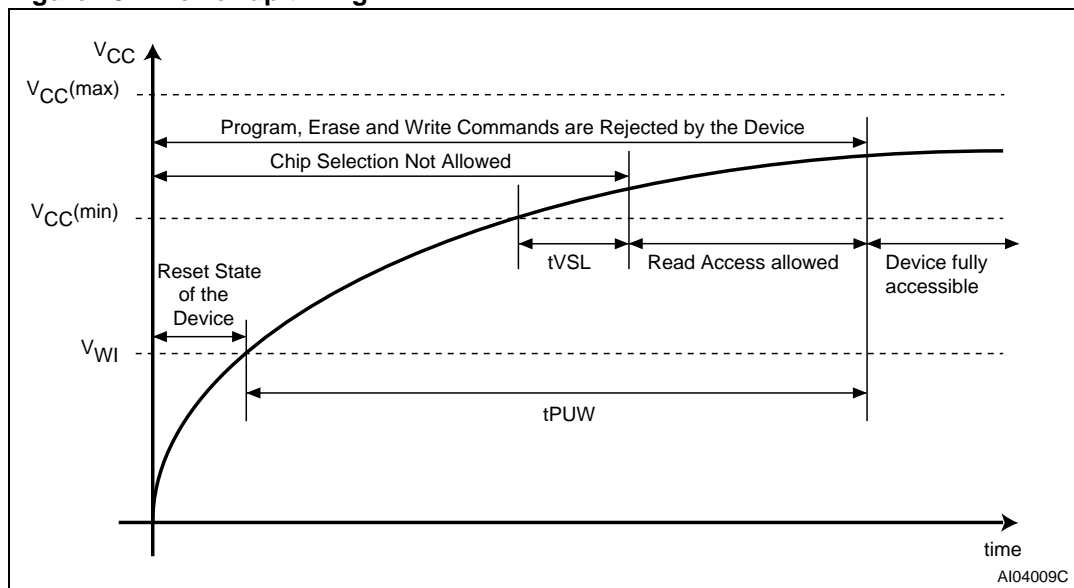
Table 8. Power-up timing and V_{WI} threshold for 65 nm devices⁽¹⁾

Symbol	Parameter	Min.	Max.	Unit
$t_{VSL}^{(2)}$	$V_{CC}(\text{min})$ to \bar{S} Low	200		μs
$t_{PUW}^{(2)}$	Time delay to Write instruction	400		μs
V_{WI}	Write Inhibit Voltage	1.5	2.5	V

- 65 nm technology devices are identified by the process identification digit 'A' in the device marking and process letter 'B' in the part number.
- These parameters are characterized only.

Table 9. Power-up timing and V_{WI} threshold for 130 nm devices

Symbol	Parameter	Min.	Max.	Unit
$t_{VSL}^{(1)}$	$V_{CC}(\text{min})$ to \bar{S} Low	60		μs
$t_{PUW}^{(2)}$	Time delay to Write instruction	1	10	ms
V_{WI}	Write Inhibit Voltage	1.5	2.5	V

- These parameters are characterized only.

8 Initial delivery state

The device is delivered with the memory array erased: all bits are set to 1 (each byte contains FFh). The Status Register contains 00h (all Status Register bits are 0).

9 Maximum rating

Stressing the device outside the ratings listed in [Table 10](#) may cause permanent damage to the device. These are stress ratings only, and operation of the device at these, or any other conditions outside those indicated in the operating sections of this specification, is not implied. Exposure to absolute maximum rating conditions for extended periods may affect device reliability.

Table 10. Absolute maximum ratings

Symbol	Parameter	Min.	Max.	Unit
T _{STG}	Storage Temperature	-65	150	°C
V _{IO}	Input and output voltage (with respect to Ground)	-0.5	V _{CC} + 0.6	V
V _{CC}	Supply voltage	-0.2	4.0	V
V _{PP}	Fast Program/Erase voltage	-0.2	10.0	V
V _{ESD}	Electrostatic Discharge Voltage (Human Body Model) ⁽¹⁾	-2000	2000	V

1. JEDEC Std JESD22-A114A (C1=100 pF, R1=1500 Ω, R2=500 Ω)

10 DC and AC parameters

This section summarizes the operating and measurement conditions, and the DC and AC characteristics of the device. The parameters in the DC and AC Characteristic tables that follow are derived from tests performed under the measurement conditions summarized in the relevant tables. Designers should check that the operating conditions in their circuit match the measurement conditions when relying on the quoted parameters.

Table 11. Operating conditions

Symbol	Parameter	Min.	Typ.	Max.	Unit
V_{CC}	Supply Voltage	2.7		3.6	V
V_{PPH}	Supply Voltage on \overline{W}/V_{PP} pin for Fast Program/Erase mode	8.5		9.5	V
T_A	Ambient Operating Temperature	-40		85	°C
T_{AVPP}	Ambient Operating Temperature for Fast Program/Erase mode	15	25	35	°C

Table 12. AC measurement conditions

Symbol	Parameter	Min.	Max.	Unit
C_L	Load Capacitance	30		pF
	Input Rise and Fall Times		5	ns
	Input Pulse Voltages	0.2 V_{CC} to 0.8 V_{CC}		V
	Input Timing Reference Voltages	0.3 V_{CC} to 0.7 V_{CC}		V
	Output Timing Reference Voltages	$V_{CC} / 2$		V

1. Output Hi-Z is defined as the point where data out is no longer driven.

Figure 19. AC measurement I/O waveform

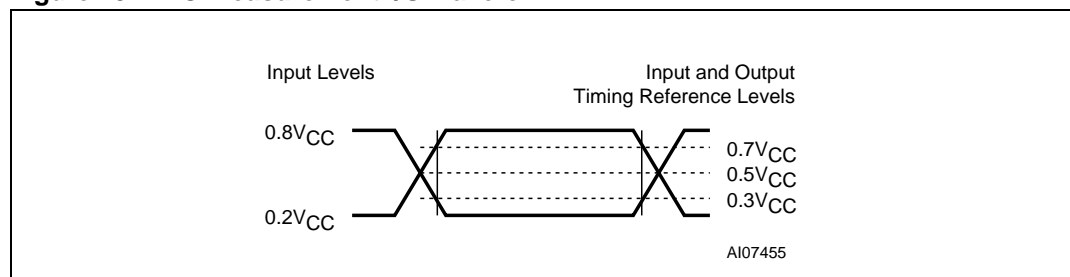

Table 13. Capacitance

Symbol	Parameter	Test Condition	Min.	Max.	Unit
C_{OUT}	Output Capacitance (Q)	$V_{OUT} = 0V$		8	pF
C_{IN}	Input Capacitance (other pins)	$V_{IN} = 0V$		6	pF

1. Sampled only, not 100% tested, at $T_A=25$ °C and a frequency of 20 MHz.

Table 14. DC characteristics for 65 nm devices⁽¹⁾

Symbol	Parameter	Test condition (in addition to those in Table 11)	Min.	Max.	Unit
I_{LI}	Input Leakage Current			± 2	μA
I_{LO}	Output Leakage Current			± 2	μA
I_{CC1}	Standby Current	$\bar{S} = V_{CC}, V_{IN} = V_{SS} \text{ or } V_{CC}$		100	μA
I_{CC3}	Operating Current (READ)	$C = 0.1V_{CC} / 0.9.V_{CC}$ at 54 MHz, Q = open		6	mA
		$C = 0.1V_{CC} / 0.9.V_{CC}$ at 33 MHz, Q = open		4	mA
I_{CC4}	Operating Current (PP)	$\bar{S} = V_{CC}$		20	mA
I_{CC5}	Operating Current (WRSR)	$\bar{S} = V_{CC}$		20	mA
I_{CC6}	Operating Current (SE)	$\bar{S} = V_{CC}$		20	mA
I_{CC7}	Operating Current (BE)	$\bar{S} = V_{CC}$		20	mA
$I_{CCPP}^{(2)}$	Operating current for Fast Program/Erase mode	$\bar{S} = V_{CC}, V_{PP} = V_{PPH}$		20	mA
$I_{PP}^{(2)}$	V_{PP} Operating current in Fast Program/Erase mode	$\bar{S} = V_{CC}, V_{PP} = V_{PPH}$		20	mA
V_{IL}	Input Low Voltage		-0.5	$0.3 V_{CC}$	V
V_{IH}	Input High Voltage		$0.7 V_{CC}$	$V_{CC}+0.4$	V
V_{OL}	Output Low Voltage	$I_{OL} = 1.6 \text{ mA}$		0.4	V
V_{OH}	Output High Voltage	$I_{OH} = -100 \mu\text{A}$	$V_{CC}-0.2$		V

1. 65 nm process technology devices are identified by the process identification digit 'A' in the device marking and process letter "B" in the part number.

2. Characterized only.

Table 15. AC characteristics for 65 nm devices⁽¹⁾

Test conditions specified in Table 11 and Table 12						
Symbol	Alt.	Parameter	Min.	Typ.	Max.	Unit
f_C	f_C	Clock frequency for the following instructions: FAST_READ, PP, SE, BE, WREN, WRDI, RDID, RDSR, WRSR	D.C.		54	MHz
f_R		Clock frequency for READ instructions	D.C.		33	MHz
$t_{CH}^{(2)}$	t_{CLH}	Clock High Time	9			ns
$t_{CL}^{(2)}$	t_{CLL}	Clock Low Time	9			ns
$t_{CLCH}^{(3)}$		Clock Rise Time ⁽⁴⁾ (peak to peak)	0.1			V/ns
$t_{CHCL}^{(3)}$		Clock Fall Time ⁽³⁾ (peak to peak)	0.1			V/ns
t_{SLCH}	t_{CSS}	\bar{S} Active Setup Time (relative to C)	4			ns
t_{CHSL}		\bar{S} Not Active Hold Time (relative to C)	4			ns

Table 15. AC characteristics for 65 nm devices⁽¹⁾ (continued)

Test conditions specified in Table 11 and Table 12						
Symbol	Alt.	Parameter	Min.	Typ.	Max.	Unit
t_{DVCH}	t_{DSU}	Data In Setup Time	2			ns
t_{CHDX}	t_{DH}	Data In Hold Time	3			ns
t_{CHSH}		\overline{S} Active Hold Time (relative to C)	4			ns
t_{SHCH}		\overline{S} Not Active Setup Time (relative to C)	4			ns
t_{SHSL}	t_{CSH}	\overline{S} Deselect Time	50			ns
$t_{SHQZ}^{(2)}$	t_{DIS}	Output Disable Time			8	ns
t_{CLQV}	t_V	Clock Low to Output Valid			8	ns
t_{CLQX}	t_{HO}	Output Hold Time	1			ns
t_{HLCH}		\overline{HOLD} Setup Time (relative to C)	4			ns
t_{CHHH}		\overline{HOLD} Hold Time (relative to C)	4			ns
t_{HHCH}		\overline{HOLD} Setup Time (relative to C)	4			ns
t_{CHHL}		\overline{HOLD} Hold Time (relative to C)	4			ns
$t_{HHQX}^{(3)}$	t_{LZ}	\overline{HOLD} to Output Low-Z			8	ns
$t_{HLQZ}^{(3)}$	t_{HZ}	\overline{HOLD} to Output High-Z			8	ns
$t_{WHSL}^{(5)}$		Write Protect Setup Time	20			ns
$t_{SHWL}^{(5)}$		Write Protect Hold Time	100			ns
$t_{VPPHSL}^{(3)}$ (6)		Enhanced Program Supply Voltage High to Chip Select Low	200			ns
t_W		Write Status Register Cycle Time		1.3	15	s
$t_{PP}^{(7)}$		Page Program Cycle Time (256 Bytes)		0.5	5	ms
		Page Program Cycle Time (n Bytes)		$\text{int}(n/8) \times 0.015^{(8)}$		
		Page Program Cycle Time ($V_{PP} = V_{PPH}$) (256 Bytes)		0.4 ⁽³⁾		
t_{SE}		Sector Erase Cycle Time		1.6	3	s
t_{SE}		Sector Erase Cycle Time ($V_{PP} = V_{PPH}$)		1.6	3	s
t_{BE}		Bulk Erase Cycle Time		130	250	s
t_{BE}		Bulk Erase Cycle Time ($V_{PP} = V_{PPH}$)		120	250	s

- 65 nm process technology devices are identified by the process identification digit 'A' in the device marking and process letter "B" in the part number.
- t_{CH} and t_{CL} must be greater than or equal to $1/f_C$ (max).
- Value is guaranteed by characterization, not 100% tested in production.
- Expressed as a slew-rate.
- Only applicable as a constraint for WRSR instruction when SRWD is set to 1.
- V_{PPH} should be kept at a valid level until the program or erase operation has completed and its result (success or failure) is known.

7. When using the Page Program (PP) instruction to program consecutive Bytes, optimized timings are obtained with one sequence including all the Bytes versus several sequences of only a few Bytes. If only a single byte is programmed, the estimated programming time is close to the time needed to program a full page of 256 Bytes. Therefore, it is highly recommended to use the Page Program (PP) instruction with a sequence of 256 consecutive Bytes. ($1 \leq n \leq 256$)
8. $\text{int}(A)$ corresponds to the upper integer part of A. For example $\text{int}(12/8) = 2$, $\text{int}(32/8) = 4$, $\text{int}(15.3) = 16$.

Table 16. DC characteristics for 130 nm devices

Symbol	Parameter	Test condition (in addition to those in <i>Table 11</i>)	Min.	Max.	Unit
I_{LI}	Input Leakage Current			± 2	μA
I_{LO}	Output Leakage Current			± 2	μA
I_{CC1}	Standby Current	$\bar{S} = V_{CC}$, $V_{IN} = V_{SS}$ or V_{CC}		100	μA
I_{CC3}	Operating Current (READ)	$C = 0.1V_{CC} / 0.9.V_{CC}$ at 50MHz, Q = open		8	mA
		$C = 0.1V_{CC} / 0.9.V_{CC}$ at 20MHz, Q = open		4	mA
I_{CC4}	Operating Current (PP)	$\bar{S} = V_{CC}$		20	mA
I_{CC5}	Operating Current (WRSR)	$\bar{S} = V_{CC}$		20	mA
I_{CC6}	Operating Current (SE)	$\bar{S} = V_{CC}$		20	mA
I_{CC7}	Operating Current (BE)	$\bar{S} = V_{CC}$		20	mA
$I_{CCPP}^{(1)}$	Operating current for Fast Program/Erase mode	$\bar{S} = V_{CC}$, $V_{PP} = V_{PPH}$		20	mA
$I_{PP}^{(2)}$	V_{PP} Operating current in Fast Program/Erase mode	$\bar{S} = V_{CC}$, $V_{PP} = V_{PPH}$		20	mA
V_{IL}	Input Low Voltage		-0.5	$0.3V_{CC}$	V
V_{IH}	Input High Voltage		$0.7V_{CC}$	$V_{CC}+0.2$	V
V_{OL}	Output Low Voltage	$I_{OL} = 1.6\text{mA}$		0.4	V
V_{OH}	Output High Voltage	$I_{OH} = -100\mu\text{A}$	$V_{CC}-0.2$		V

1. Characterized only.

Table 17. AC characteristics for 130 nm devices

Test conditions specified in Table 11 and Table 12						
Symbol	Alt.	Parameter	Min.	Typ.	Max.	Unit
f_C	f_C	Clock frequency for the following instructions: FAST_READ, PP, SE, BE, WREN, WRDI, RDID, RDSR, WRSR	D.C.		50	MHz
f_R		Clock frequency for READ instructions	D.C.		20	MHz
$t_{CH}^{(1)}$	t_{CLH}	Clock High Time	9			ns
$t_{CL}^{(1)}$	t_{CLL}	Clock Low Time	9			ns
$t_{CLCH}^{(2)}$		Clock Rise Time ⁽³⁾ (peak to peak)	0.1			V/ns
$t_{CHCL}^{(2)}$		Clock Fall Time ⁽³⁾ (peak to peak)	0.1			V/ns
t_{SLCH}	t_{CSS}	\overline{S} Active Setup Time (relative to C)	5			ns
t_{CHSL}		\overline{S} Not Active Hold Time (relative to C)	5			ns
t_{DVCH}	t_{DSU}	Data In Setup Time	2			ns
t_{CHDX}	t_{DH}	Data In Hold Time	5			ns
t_{CHSH}		\overline{S} Active Hold Time (relative to C)	5			ns
t_{SHCH}		\overline{S} Not Active Setup Time (relative to C)	5			ns
t_{SHSL}	t_{CSH}	\overline{S} Deselect Time	100			ns
$t_{SHQZ}^{(2)}$	t_{DIS}	Output Disable Time			8	ns
t_{CLQV}	t_V	Clock Low to Output Valid			8	ns
t_{CLQX}	t_{HO}	Output Hold Time	0			ns
t_{HLCH}		\overline{HOLD} Setup Time (relative to C)	5			ns
t_{CHHH}		\overline{HOLD} Hold Time (relative to C)	5			ns
t_{HHCH}		\overline{HOLD} Setup Time (relative to C)	5			ns
t_{CHHL}		\overline{HOLD} Hold Time (relative to C)	5			ns
$t_{HHQX}^{(2)}$	t_{LZ}	\overline{HOLD} to Output Low-Z			8	ns
$t_{HLQZ}^{(2)}$	t_{HZ}	\overline{HOLD} to Output High-Z			8	ns
$t_{WHSL}^{(4)}$		Write Protect Setup Time	20			ns
$t_{SHWL}^{(4)}$		Write Protect Hold Time	100			ns
$t_{VPPHSL}^{(2)(5)}$		Enhanced Program Supply Voltage High to Chip Select Low	200			ns
t_W		Write Status Register Cycle Time		5	15	ms
$t_{PP}^{(6)}$		Page Program Cycle Time (256 Bytes)		2.5	7	ms
		Page Program Cycle Time (n Bytes)		2.5		
		Page Program Cycle Time ($V_{PP} = V_{PPH}$) (256 Bytes)		1.2 ⁽²⁾		
t_{SE}		Sector Erase Cycle Time		2	6	s
		Sector Erase Cycle Time ($V_{PP} = V_{PPH}$)		1.6 ⁽²⁾		

Table 17. AC characteristics for 130 nm devices (continued)

Test conditions specified in Table 11 and Table 12						
Symbol	Alt.	Parameter	Min.	Typ.	Max.	Unit
t_{BE}		Bulk Erase Cycle Time		105	250	s
		Bulk Erase Cycle Time ($V_{PP} = V_{PPH}$)		56 ⁽²⁾		

- t_{CH} and t_{CL} must be greater than or equal to $1/f_C$ (max).
- Value is guaranteed by characterization, not 100% tested in production.
- Expressed as a slew-rate.
- Only applicable as a constraint for WRSR instruction when SRWD is set to 1.
- V_{PPH} should be kept at a valid level until the program or erase operation has completed and its result (success or failure) is known.
- When using the Page Program (PP) instruction to program consecutive Bytes, optimized timings are obtained with one sequence including all the Bytes versus several sequences of only a few Bytes. If only a single byte is programmed, the estimated programming time is close to the time needed to program a full page of 256 Bytes. Therefore, it is highly recommended to use the Page Program (PP) instruction with a sequence of 256 consecutive Bytes. ($1 \leq n \leq 256$)

Figure 20. Serial input timing

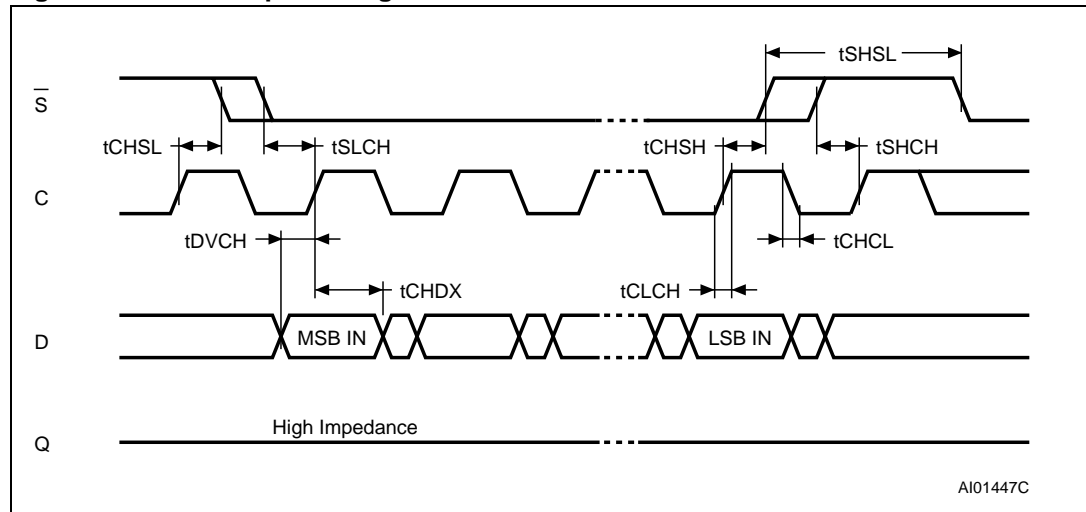

AI01447C

Figure 21. Write protect setup and hold timing during WRSR when SRWD =1

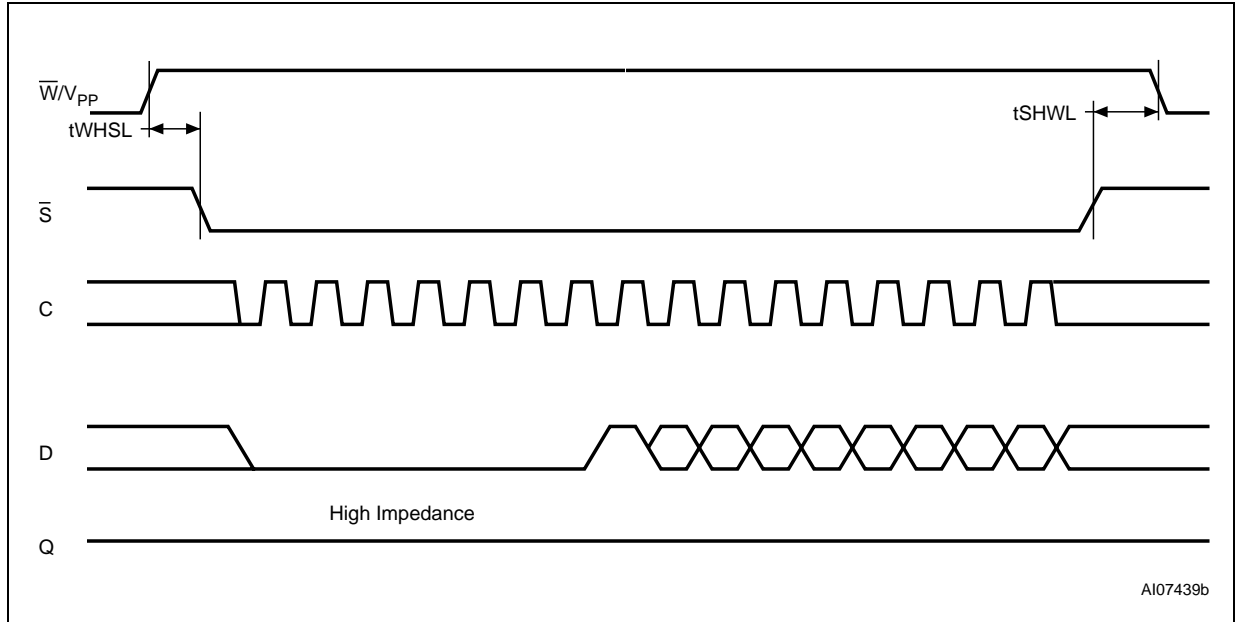

Figure 22. Hold timing

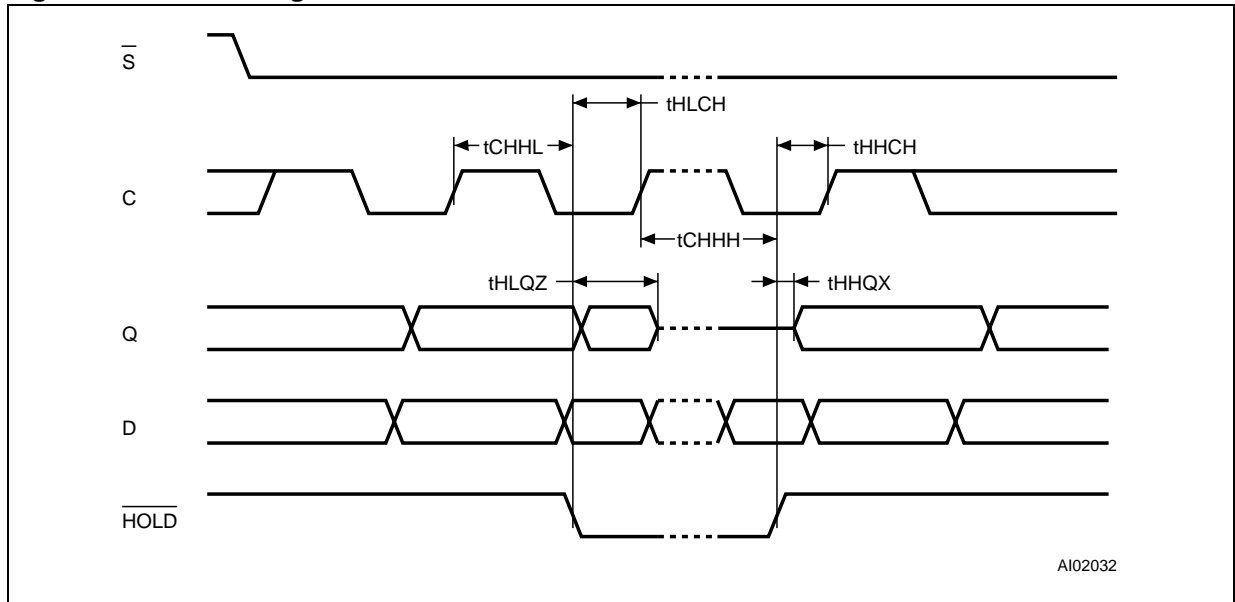

Figure 23. Output timing

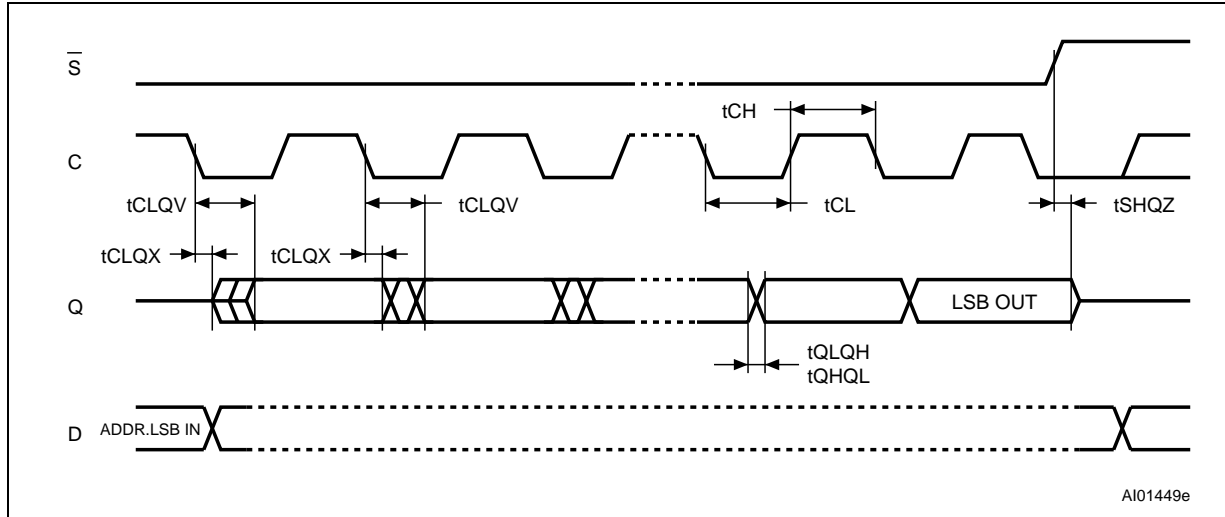
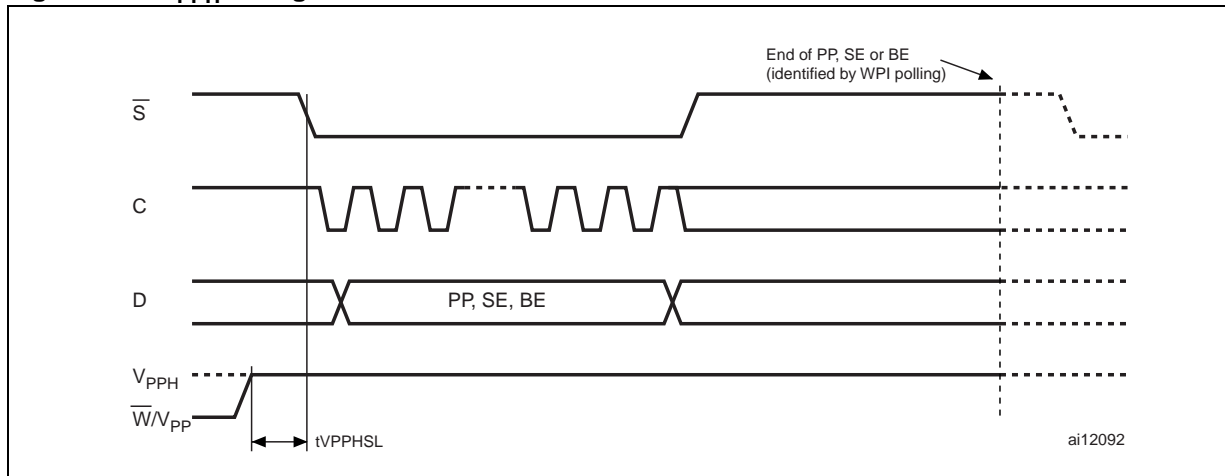
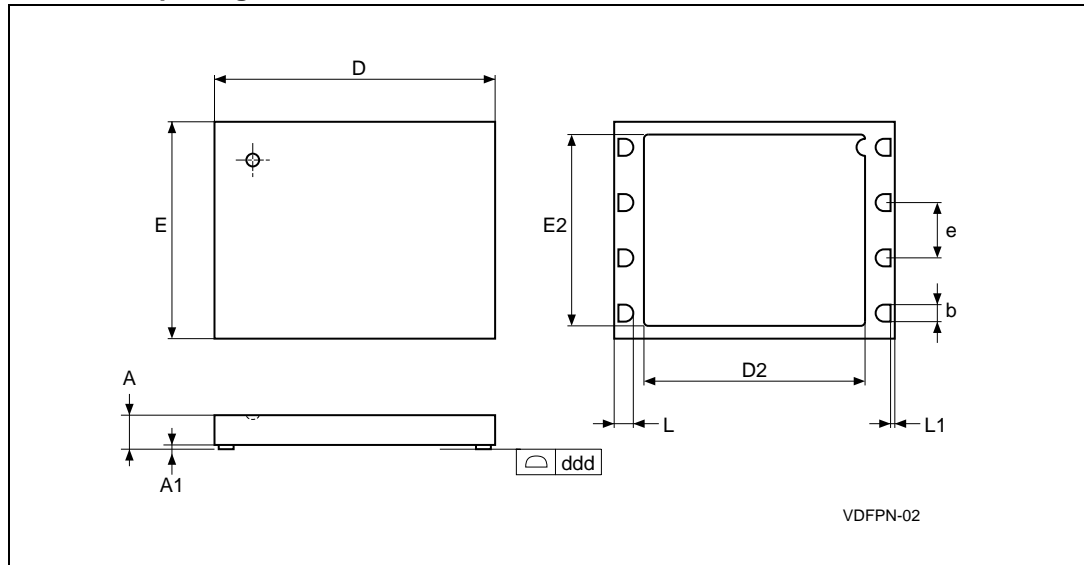

Figure 24. V_{PPH} timing



11 Package mechanical

Figure 25. VDFPN8 (MLP8), 8-lead Very thin Dual Flat Package No lead, 8x6mm, package outline



1. Drawing is not to scale.
2. The circle in the top view of the package indicates the position of pin 1.

Table 18. VDFPN8 (MLP8), 8-lead Very thin Dual Flat Package No lead, 8 × 6mm, package mechanical data

Symbol	millimeters			inches		
	Typ.	Min.	Max.	Typ.	Min.	Max.
A	0.85		1.00	0.0335		0.0394
A1		0.00	0.05		0.0000	0.0020
b	0.40	0.35	0.48	0.0157	0.0138	0.0189
D	8.00			0.3150		
D2	5.16		(1)	0.2031		
ddd			0.05			0.0020
E	6.00			0.2362		
E2	4.80			0.1890		
e	1.27	–	–	0.0500	–	–
K		0.20			0.0079	
L	0.50	0.45	0.60	0.0197	0.0177	0.0236
L1			0.15			0.0059
N	8			8		

1. D2 Max should not exceed $(D - K - 2 \times L)$.

Figure 26. SO16 wide – 16 lead Plastic Small Outline, 300 mils body width

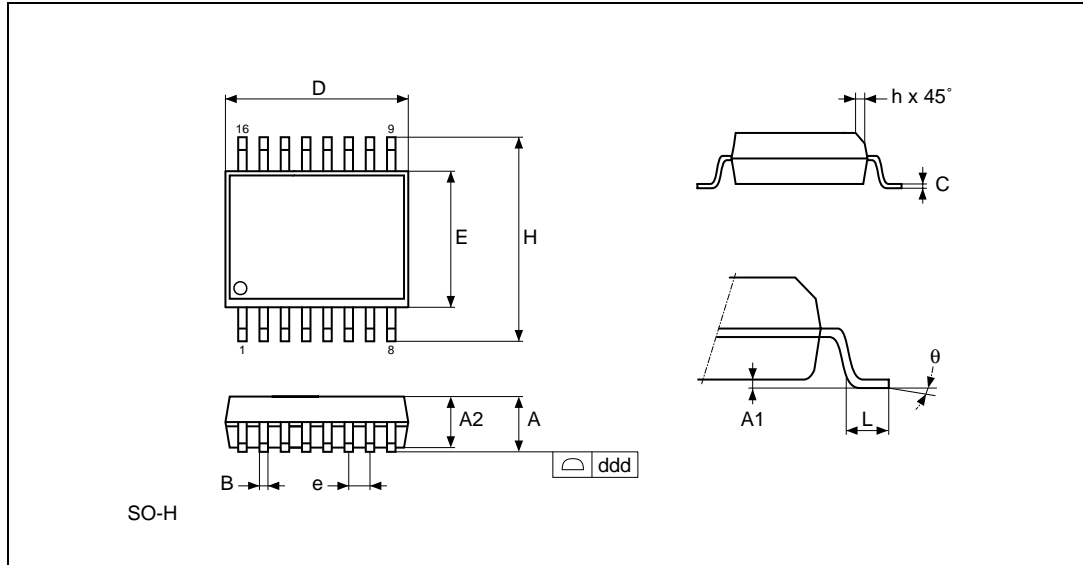

1. Drawing is not to scale.

Table 19. SO16 wide – 16 lead Plastic Small Outline, 300 mils body width

Symbol	millimeters			inches		
	Typ	Min	Max	Typ	Min	Max
A		2.35	2.65		0.093	0.104
A1		0.10	0.30		0.004	0.012
B		0.33	0.51		0.013	0.020
C		0.23	0.32		0.009	0.013
D		10.10	10.50		0.398	0.413
E		7.40	7.60		0.291	0.299
e	1.27	–	–	0.050	–	–
H		10.00	10.65		0.394	0.419
h		0.25	0.75		0.010	0.030
L		0.40	1.27		0.016	0.050
θ		0°	8°		0°	8°
ddd			0.10			0.004

12 Ordering information

Table 20. Ordering information scheme

Example:	M25P128	-	V	MF	6	T	P	B
Device Type								
M25P = Serial flash memory for code storage								
Device function								
128 = 128 Mbit (16 Mbit × 8)								
Operating voltage								
V = V _{CC} = 2.7 to 3.6 V								
Package								
MF = SO16 (300 mil width)								
ME = VDFPN8 8 x 6 mm (MLP8)								
Device grade								
6 = Industrial temperature range, -40 to 85 °C. Device tested with standard test flow								
Option								
blank = Standard packing T = Tape and reel packing								
Plating technology								
P or G = RoHS compliant								
Process Technology								
Blank = 130nm MLC B = 65 nm SLC								

For a list of available options (speed, package, etc.) or for further information on any aspect of this device, please contact your nearest Numonyx sales office.

The category of second-level interconnect is marked on the package and on the inner box label, in compliance with JEDEC Standard JESD97. The maximum ratings related to soldering conditions are also marked on the inner box label.

13 Revision history

Table 21. Document revision history

Date	Revision	Changes
02-May-2005	0.1	First issue.
09-Jun-2005	0.2	Table 2: Protected area sizes updated. Memory capacity modified in Section 6.3: Read identification (RDID) .
28-Aug-2005	0.3	Updated t_{PP} values in Table 17: AC characteristics for 130 nm devices and t_{VSL} value in Table 8: Power-up timing and VWI threshold for 65 nm devices . Modified information in Section 4.1: Page programming and Section 6.8: Page program (PP) .
20-Jan-2006	1	Document status promoted from Target specification to Preliminary data. Packages are ECOPACK® compliant. Blank option removed under Plating technology in Table 20 . Read Electronic Signature (RES) instruction removed. I_{CC1} parameter updated in Table 14: DC characteristics for 65 nm devices .
17-Oct-2006	2	Document status promoted from Preliminary Data to full Datasheet. Write Protect pin (\overline{W}) changed to Write protect/enhanced program supply voltage (W/VPP) . Section 4.4: Fast program/erase mode and Figure 24: VPPH timing added. Power-up specified for Fast Program/Erase mode in Power-up and power-down section. Figure 4: Bus master and memory devices on the SPI bus modified and Note 2 added. Note 1 added below Table 18: VDFPN8 (MLP8), 8-lead Very thin Dual Flat Package No lead, 8 x 6mm, package mechanical data . V_{IO} max modified in Table 10: Absolute maximum ratings .
10-Dec-2007	3	Applied Numonyx branding.
26-Nov-2009	4	Removed references to multilevel cell technology and ECOPACK® packages. Added: Table 14: DC characteristics for 65 nm devices and Table 15: AC characteristics for 65 nm devices , and references to 65 nm process technology throughout the document Modified D2 value in Table 18: VDFPN8 (MLP8), 8-lead Very thin Dual Flat Package No lead, 8 x 6mm, package mechanical data .
17-Dec-2009	5	Added "Process Technology" to Ordering Information table.
1-Feb-2010	6	Added sector erase cycle times to Table 15.: AC characteristics for 65 nm devices . Changed I_{CC3} test conditions in Table 14.: DC characteristics for 65 nm devices as follows: 50 MHz to 54 MHz and 20 MHz to 33 MHz.

Please Read Carefully:

INFORMATION IN THIS DOCUMENT IS PROVIDED IN CONNECTION WITH NUMONYX™ PRODUCTS. NO LICENSE, EXPRESS OR IMPLIED, BY ESTOPPEL OR OTHERWISE, TO ANY INTELLECTUAL PROPERTY RIGHTS IS GRANTED BY THIS DOCUMENT. EXCEPT AS PROVIDED IN NUMONYX'S TERMS AND CONDITIONS OF SALE FOR SUCH PRODUCTS, NUMONYX ASSUMES NO LIABILITY WHATSOEVER, AND NUMONYX DISCLAIMS ANY EXPRESS OR IMPLIED WARRANTY, RELATING TO SALE AND/OR USE OF NUMONYX PRODUCTS INCLUDING LIABILITY OR WARRANTIES RELATING TO FITNESS FOR A PARTICULAR PURPOSE, MERCHANTABILITY, OR INFRINGEMENT OF ANY PATENT, COPYRIGHT OR OTHER INTELLECTUAL PROPERTY RIGHT.

Numonyx products are not intended for use in medical, life saving, life sustaining, critical control or safety systems, or in nuclear facility applications.

Numonyx may make changes to specifications and product descriptions at any time, without notice.

Numonyx, B.V. may have patents or pending patent applications, trademarks, copyrights, or other intellectual property rights that relate to the presented subject matter. The furnishing of documents and other materials and information does not provide any license, express or implied, by estoppel or otherwise, to any such patents, trademarks, copyrights, or other intellectual property rights.

Designers must not rely on the absence or characteristics of any features or instructions marked "reserved" or "undefined." Numonyx reserves these for future definition and shall have no responsibility whatsoever for conflicts or incompatibilities arising from future changes to them.

Contact your local Numonyx sales office or your distributor to obtain the latest specifications and before placing your product order.

Copies of documents which have an order number and are referenced in this document, or other Numonyx literature may be obtained by visiting Numonyx's website at <http://www.numonyx.com>.

Numonyx StrataFlash is a trademark or registered trademark of Numonyx or its subsidiaries in the United States and other countries.

*Other names and brands may be claimed as the property of others.

Copyright © 2010, Numonyx, B.V., All Rights Reserved.

Looking for pricing, stock, or lifecycle information?

Click below to explore more details on WIN SOURCE:

- ⊖ [View M25P128-VMF6P on WIN SOURCE](#)
- ⊖ [Micron Technology Inc. Information](#)

Optimize Your Supply Chain with WIN SOURCE Solutions

- ✓ Global Sourcing Solution
- ✓ Obsolete Management
- ✓ Cost Control Management
- ✓ Shortage Management
- ✓ Alternative Solution
- ✓ Excess Inventory Management