



**THE DATASHEET OF  
M02042G-4D03-T**



## Preliminary Information

This document contains information on a new product. The parametric information, although not fully characterized, is the result of testing initial devices.

## MC2042-4

### LED/Laser Driver for FDDI, Fast Ethernet, Fibre Channel, OC3/STM-1, IEEE1394

The MC2042-4 is a CMOS IC designed for high-speed LED drive in low-cost optical fiber based transmission systems. Depending on the LED used, data rates to >300 Mbps can be achieved.

The LED drive current is set by a resistor. To improve LED 'on' time, a pre-emphasis circuit is included, which may be set via a simple RC network.

To minimize the effects of temperature on LED output power, LED drive temperature compensation can be set by resistor over a 500 - 10,000 ppm/°C range.

Differential positive-ECL (PECL) data on the input pins can be shaped, if desired, by the differential voltage on the Pulse Width Adjust (PWA) pins. This adjustment is continuous over a  $\pm 500$  ps range. In addition, the  $V_{REF}$  output pin allows single-ended input to the MC2042 and provides compatibility with industry-standard FO modules.

### Applications

- FDDI, Fiber Channel
- Fast Ethernet, IEEE1394
- OC3/STM1

### Features

- Data rates to >300 Mbps, depending on LED
- Single chip solution, available as die or in TSSOP20 or QSOP16 fabricated in deep sub-micron CMOS for lowest cost & power consumption and long term reliability
- Programmable output current from 5 mA to 120 mA
- RC programmable pre-emphasis or 'peaking' circuit giving drive current rise and fall times <500 ps
- Resistor programmable compensation for temperature dependence of LED output power
- PECL input with optional Pulse Width Adjust
- Single-ended CMOS input compatible at low speeds
- $V_{REF}$  voltage generator and output pin
- Supports most LED types (e.g. 660 to 1300 nm)
- Single +5 V to +3.3 V operation
- Available in RoHS-compliant packages

Block Diagram

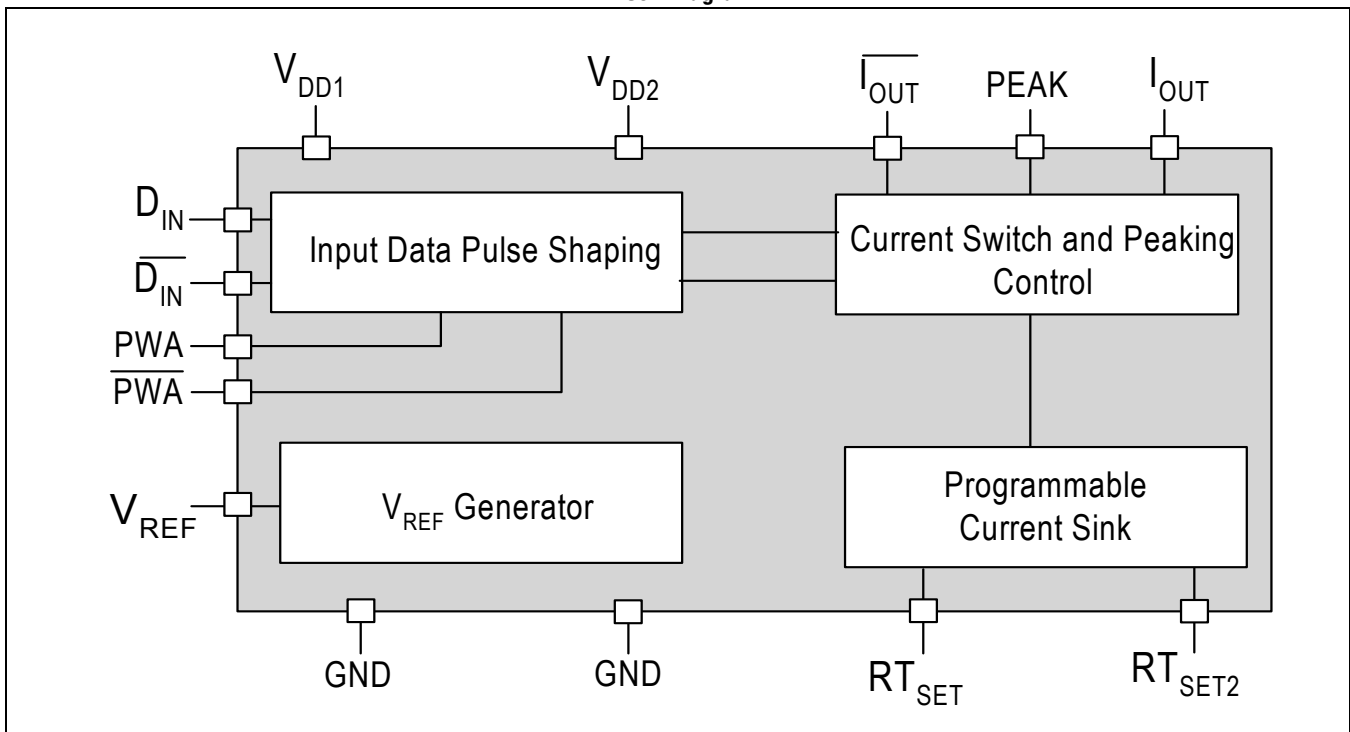

## Ordering Information

Part Number	Package	Operating Temperature
M02042-4-xxx	Waffle Pack Expanded Whole Wafer on a Ring QSOP16 TSSOP20 QSOP16 Tape and Reel TSSOP20 Tape and Reel	-40 °C to 85 °C
M02042G-4-xxx *	Waffle Pack Expanded Whole Wafer on a Ring QSOP16 TSSOP20 QSOP16 Tape and Reel TSSOP20 Tape and Reel	-40 °C to 85 °C

**Notes:**

- \* The letter "G" designator after the part number indicates that the device is RoHS-compliant. Refer to [www.mindspeed.com](http://www.mindspeed.com) for additional information.
- xxx represents the revision number. Please contact your local sales office for correct digits.
- Because the current Mindspeed part number standard uses an M0 prefix, it is used for ordering the MC2042 but the part is still marked as an MC2042 device.

## Revision History

Revision	Level	Date	ASIC Revision	Description
D	Preliminary	September 2005		Minor update in new data sheet format. Added references to lead-free and RoHS-compliant options. ILED_ON specification change.
C	Preliminary	August 2003		Revision C release.

**Typical Eye Diagram**

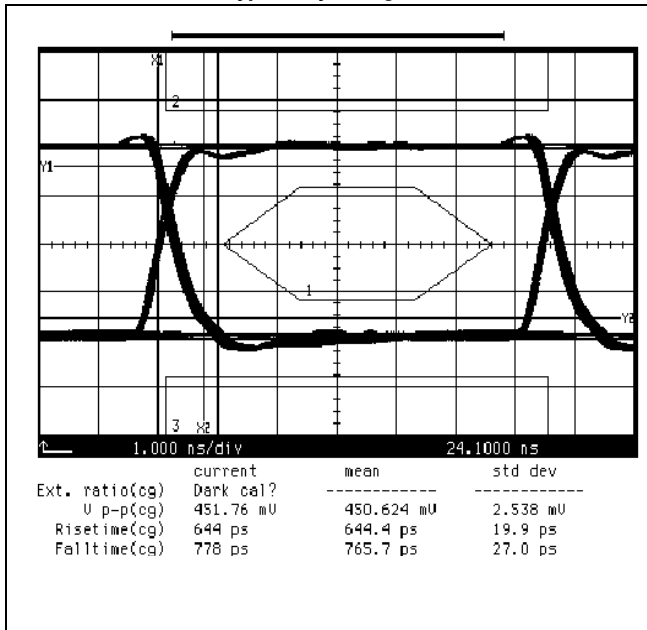

**Pin Configuration**

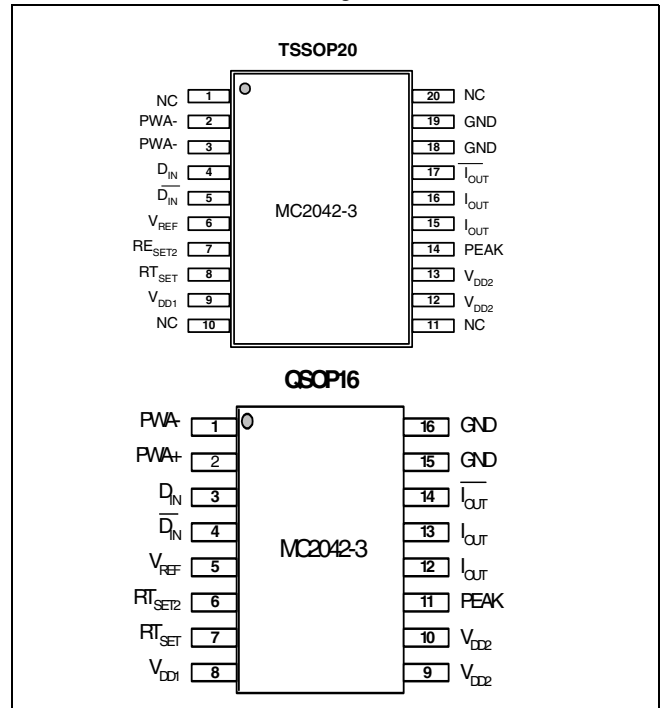

Preliminary Information



# 1.0 Product Specification

## 1.1 Absolute Maximum Ratings

These are the absolute maximum ratings at or beyond which the IC can be expected to fail or be damaged. Reliable operation at these extremes for any length of time is not implied.

Note: The package bottom must be adequately grounded to ensure correct thermal and electrical performance, and it is recommended that vias are inserted through to a lower ground plane.

**Table 1-1. Absolute Maximum Ratings**

Symbol	Parameter	Rating	Units
$P_{TOT}$	Total power dissipation (TSSOP20)	255	mW
$V_{CC}$	Power supply ( $V_{CC}$ -GND)	7	V
$T_J$	Junction temperature	150	°C
$T_A$	Operating ambient	-40 to +85	°C
$T_{STG}$	Storage temperature	-65 to +150	°C

## 1.2 DC Characteristics

$V_{CC} = +3.3V \pm 7.5\%$  or  $+5V \pm 7.5\%$ ,  $T_A = -40^\circ C$  to  $+85^\circ C$ , unless otherwise noted.

Typical specifications are for  $V_{CC} = 3.3V$ ,  $T_A = 25^\circ C$ , unless otherwise noted.

**Table 1-2. DC Characteristics**

Symbol	Parameter	Min	Typ	Max	Units
$V_{CC}$	Supply Voltage	3.0	-	5.5	V
$V_{Din}$	Allowable voltage at data inputs	Gnd - 0.3	-	$V_{CC} + 0.3$	
$V_{REF}$	Voltage reference	$V_{CC} - 1.6$	$V_{CC} - 1.4$	$V_{CC} - 1.03$	
$I_{LED\ ON}^1$	LED drive current	5	-	120	mA
$I_{LED\ OFF}$	LED off current	-	-	50	$\mu A$
$I_{COMP}$	LED drive current temperature compensation range	0.05	-	1	%/°C
$V_{LED\_H}$	Minimum allowable voltage at IOOUT	$V_{DD} - 2.0$	-	-	V

1. The LED drive current adjustment range will decrease from 120 mA for  $V_{CC} \geq 3.3V$  to 100 mA at  $V_{CC} = 3V$ . In all cases, the designer should verify that the absolute maximum total power dissipation specification and the absolute maximum junction temperature specification are not violated.

## 1.3 AC Characteristics

$V_{CC} = +3.3V \pm 7.5\%$  or  $+5V \pm 7.5\%$ ,  $T_A = -40^{\circ}C$  to  $+85^{\circ}C$ , input bit rate = 1.25 Gbps  $2^{23}$ -1 PRBS unless otherwise noted. Typical specifications are for  $V_{CC} = 3.3V$ ,  $T_A = 25^{\circ}C$ , unless otherwise noted.

**Table 1-3. AC Characteristics**

Symbol	Parameter	Min	Typ	Max	Units
$V_{in(Diff)}$	Differential Input Voltage, $2 \cdot (D_{inH} - D_{inL})$	300mV	-	$2 \cdot V_{CC}$	V
	Common Mode Input Voltage	$V_{CC}/2$	-	$(V_{CC} - V_{in(Diff)})/4$	V
$f_C$	Maximum data rate	300	-	-	Mbps
$T_{PWA}$	Input data pulse width adjust range	-500	-	500	ps
LED $t_r$	LED drive rise time	-	0.7	1	ns
LED $t_f$	LED drive fall time	-	0.7	1	ns
$I_{PEAK}$	Peaking current (as % of LED drive current)	0	-	50	%
PEAK $t_r$	Peaking current rise time	-	-	1	ns
PEAK $t_f$	Peaking current fall time	-	-	1	ns
PEAK $t_d$	Peaking current decay time	-	$C1 \times (R4+5)$	-	S
$I_{DD}$	Supply current	-	$I_{LED} + 10$	$I_{LED} + 20$	mA

Preliminary Information



## 2.0 Pin Definitions

**Table 2-1. Pin Descriptions**

TSSOP20 Pin	QSOP16 Pin	Die Pin	Name	Description
1	-	-	NC	Not connected, leave open
2	1	13	PWA	Inverse pulse width adjust input
3	2	14	PWA	Differential pulse width adjust input. Allows continuous adjustment of input data pulse width
4	3	15	D <sub>IN</sub>	Differential data input
5	4	16	D <sub>IN</sub>	Inverse differential data input
6	5	1	V <sub>REF</sub>	Reference output. Can be used with single-ended data input.
7	6	2	RT <sub>SET2</sub>	Temperature compensation adjustment pin. Allows temperature dependence of LED light output to be reduced or removed.
8	7	3	RT <sub>SET</sub>	Sets nominal LED drive current
9	8	4	V <sub>DD1</sub>	Power pin, connect to most positive supply
10	-	-	NC	Not connected
11	-	-	NC	Not connected
12	9	5	V <sub>DD2</sub>	LED shorting pin, connect to most positive supply. Speeds LED switch off
13	10	6	V <sub>DD2</sub>	LED shorting pin, connect to most positive supply. Speeds LED switch off
14	11	7	PEAK	Connection for pre-emphasis or peaking circuit
15	12	8	I <sub>OUT</sub>	Driver output. Connect LED between this pin and V <sub>DD</sub>
16	13	9	I <sub>OUT</sub>	Driver output. Connect LED between this pin and V <sub>DD</sub>
17	14	10	I <sub>OUT</sub>	Logical inverse of pin I <sub>OUT</sub> . Connect resistor of approximately the same value as LED (at the programmed drive current level) between this pin and V <sub>DD</sub>
18	15	11	GND	Ground pin. Connect to the most negative supply
19	16	12	GND	Ground pin. Connect to the most negative supply
20	-	-	NC	Not connected, leave open

Preliminary Information

Figure 2-1. Bare Die

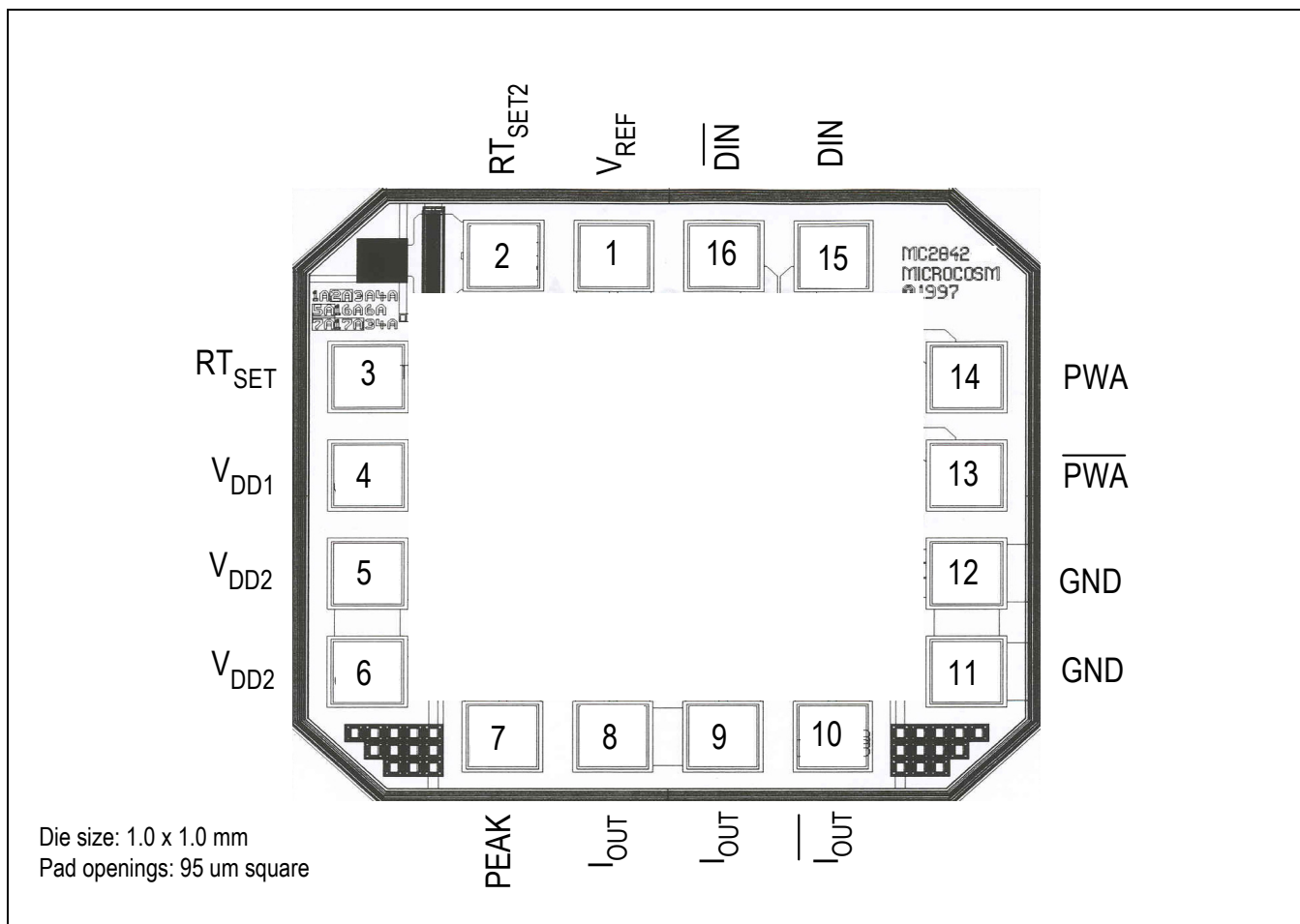

Preliminary Information

Table 2-2. Bare Die Pad Coordinates

Pad	Description	X	Y	Pad	Description	X	Y
1	V <sub>REF</sub>	-73	394.5	9	I <sub>OUT</sub>	73	-394.5
2	RT <sub>SET2</sub>	-219	394.5	10	I <sub>OUT</sub>	219	-394.5
3	RT <sub>SET</sub>	-397	214.7	11	GND	397	-223.3
4	V <sub>DD1</sub>	-397	68.7	12	GND	397	-77.3
5	V <sub>DD2</sub>	-397	-77.3	13	PWA	397	68.7
6	V <sub>DD2</sub>	-397	-223.3	14	PWA	397	214.7
7	PEAK	-219	-394.5	15	D <sub>IN</sub>	219	394.5
8	I <sub>OUT</sub>	-73	-394.5	16	D <sub>IN</sub>	73	394.5



## 3.0 Functional Description

---

### 3.1 Overview

The MC2042-4 is a CMOS IC designed for high-speed LED drive in low-cost optical fiber based transmission systems. Depending on the LED used, data rates to >300 Mbps can be achieved.

The LED drive current is set by a resistor. To improve LED 'on' time, a pre-emphasis circuit is included, which may be set via a simple RC network.

To minimize the effects of temperature on LED output power, LED drive temperature compensation can be set by resistor over a 500 - 10,000 ppm/°C range.

Differential positive-ECL (PECL) data on the input pins can be shaped, if desired, by the differential voltage on the Pulse Width Adjust (PWA) pins. This adjustment is continuous over a  $\pm 500$  ps range. In addition, the  $V_{REF}$  output pin allows single-ended input to the MC2042 and provides compatibility with industry-standard FO modules.

#### 3.1.1 Signal Path Description

Differential Positive-ECL (PECL) data on the data input pins controls the LED current switch. The LED current flows either through the LED or via the dummy load so that  $V_{DD}$  noise is minimized. To reduce LED 'turn-off' time, the LED is momentarily short-circuited, via  $V_{DD2}$ , before the current is switched to the dummy load.

#### 3.1.2 LED Drive and Temperature Compensation

The LED drive current and temperature compensation is set by the two resistors R1 and R2. The simplified application diagram (Figure 3) shows R1 connected between  $RT_{SET}$  and GND, and R2 between  $RT_{SET}$  and the  $RT_{SET2}$  pin.

The current flowing out of the  $RT_{SET}$  pin determines the LED drive current.

The temperature independent component of the LED drive current is set primarily by R1. The temperature dependent component by R2. However, R1 and R2 are not independent.

The  $RT_{SET2}$  pin connects to an internal diode on the IC which exhibits standard diode behaviour with temperature. As temperature rises, the voltage on the diode drops, the current flowing through R2 increases and the LED drive current increases.

Given the various interdependencies of the drive current, R1, R2, and temperature compensation, the relationships have been tabulated (see Temperature Compensation table). Please contact Mindspeed if other combinations are required.

The LED 'on' current is controlled to  $\pm 5\%$ .

A Microsoft Excel file is available from Mindspeed which will calculate appropriate values for  $RT_{SET}$  resistors R1 and R2 given your LED current, forward voltage, and LED temperature coefficient. The file may be obtained from a Mindspeed Field Applications Engineer and is named '*MC2042-4 resistor selection.xls*'.

**Figure 3-1. LED Drive and Temperature Compensation**

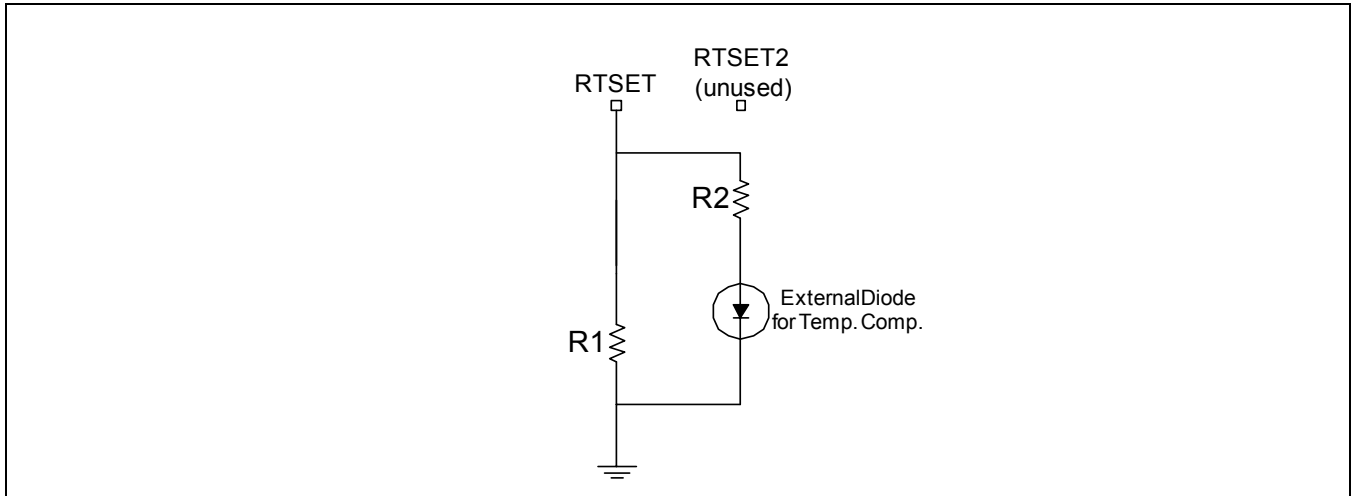

### 3.1.3 Transmit Enable/Disable

There is no dedicated pin on the MC2042 to disable the LED drive current. However, the LED drive current can be disabled by disabling the current out of pin  $RT_{SET}$ . The LED current is approximately 100x the current out of pin  $RT_{SET}$ , so if the current out of this pin is 0, the LED drive current is 0. However, if peaking is used the peaking current will not be disabled.

Figure 3-2 illustrates how the current out of  $RT_{SET}$  can be disabled by adding a MOSFET (Q1) at the  $RT_{SET}$  node of the R1/R2 temperature compensation network. The voltage on the gate of Q1 then controls transmit enable/disable. When selecting Q1, a MOSFET should be chosen with an  $R_{ds(on)}$  which is negligible compared to R1 and R2.

**Figure 3-2. Transmit Enable/Disable**

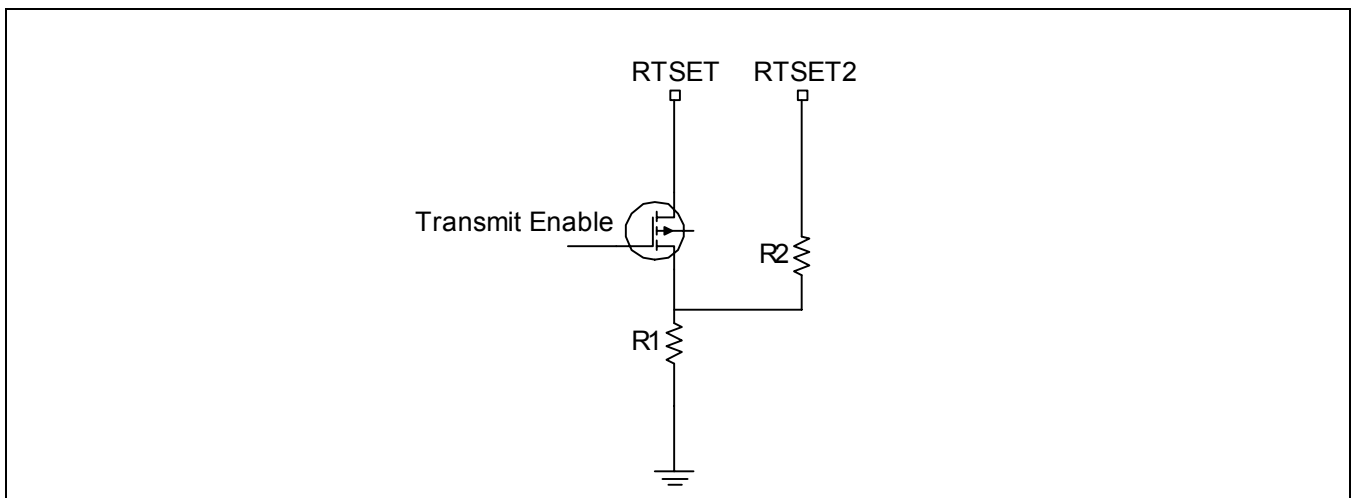

Preliminary Information

### 3.1.4 Pre-Emphasis Or ‘Peaking’

To improve LED ‘turn on’ time an optional pre-emphasis function is included on the MC2042-4. If this is not required, then the PEAK pin should be left floating. Two external components (R4, C1) are required as shown in [Figure 4-1](#) to implement peaking.

When the LED is turned on, the voltage on PEAK is pulled LOW very rapidly. This voltage transient is coupled through R4 and C1 and exerts a transient current on the LED. When the LED is turned off, the voltage on PEAK is pulled HIGH rapidly. This voltage transient is coupled through R4 and C1 and exerts a transient current in the opposite direction on the LED.

The transient current amplitude and RC decay are given approximately by:

$$\text{Peak current (Amps): } 4/(R4 + 5)$$

$$\text{Decay (seconds): } C1 \times (R4 + 5)$$

The above approximations assume an ideal LED model with 0 Ohms resistance. Real LEDs will slightly alter the peaking effect. Typical values for R4 and C1 are:

$$R4 = 50 \Omega$$

$$C1 = 20 \text{ pF}$$

### 3.1.5 LED Clamping, Laser Driving

Since most LEDs exhibit a longer ‘turn off’ time than ‘turn on’ time, a clamping function is included on the MC2042 in order to reduce the ‘turn off’ time. Clamping is enabled via the two  $V_{DD2}$  connections.

The disadvantage of clamping is that the LED’s internal capacitance has to be fully charged again before the LED starts to emit light. This delayed ‘turn on’ effect becomes noticeable when the nominal LED drive current is low. Use of the peaking circuit helps solve this problem. Thus, the combination of peaking and clamping results in very fast ‘turn on’ and ‘turn off’ times for the LED.

When driving lasers, it will often be helpful to disable this clamping. This can be achieved by leaving the  $V_{DD2}$  connections floating.  $V_{DD1}$  must still be connected.

### 3.1.6 LED Drive Pulse Width Adjust (PWA)

The input pulse width can be adjusted prior to application to the LED switch. The differential voltage on the PWA (Pulse Width Adjust) pins shapes the input pulse linearly over a nominal -500 to +500 ps range, according to the formula:

$$\text{Delta PW (ps)} = K \times V_{PWA}$$

Where:

$$K = 500 \pm 100$$

and

$$V_{PWA} = (V_{PWA+}) - (V_{PWA-})$$

The maximum range for  $V_{PWA}$  is  $\pm 1V$ . The input impedance is 3.6 k $\Omega$ .  $V_{PWA+}$  and  $V_{PWA-}$  will settle at a nominal voltage equal to  $(0.6 \times V_{DD})$  if left floating. It is recommended that adjustment be implemented by pull down resistors on PWA+ or PWA-. However, it is common for one or other pin to be tied to ground as a zero-cost, ‘gross’ adjustment.

If pulse width adjustment is not required PWA+ and PWA- should be tied to ground.

### 3.1.7 Eye Diagram

The eye diagram below is typical of the electrical output of the MC2042-4. The crossover point can be moved up and down using the PWA pin. The overshoot can be increased by using the PEAK pin.

Figure 3-3. Eye Diagram

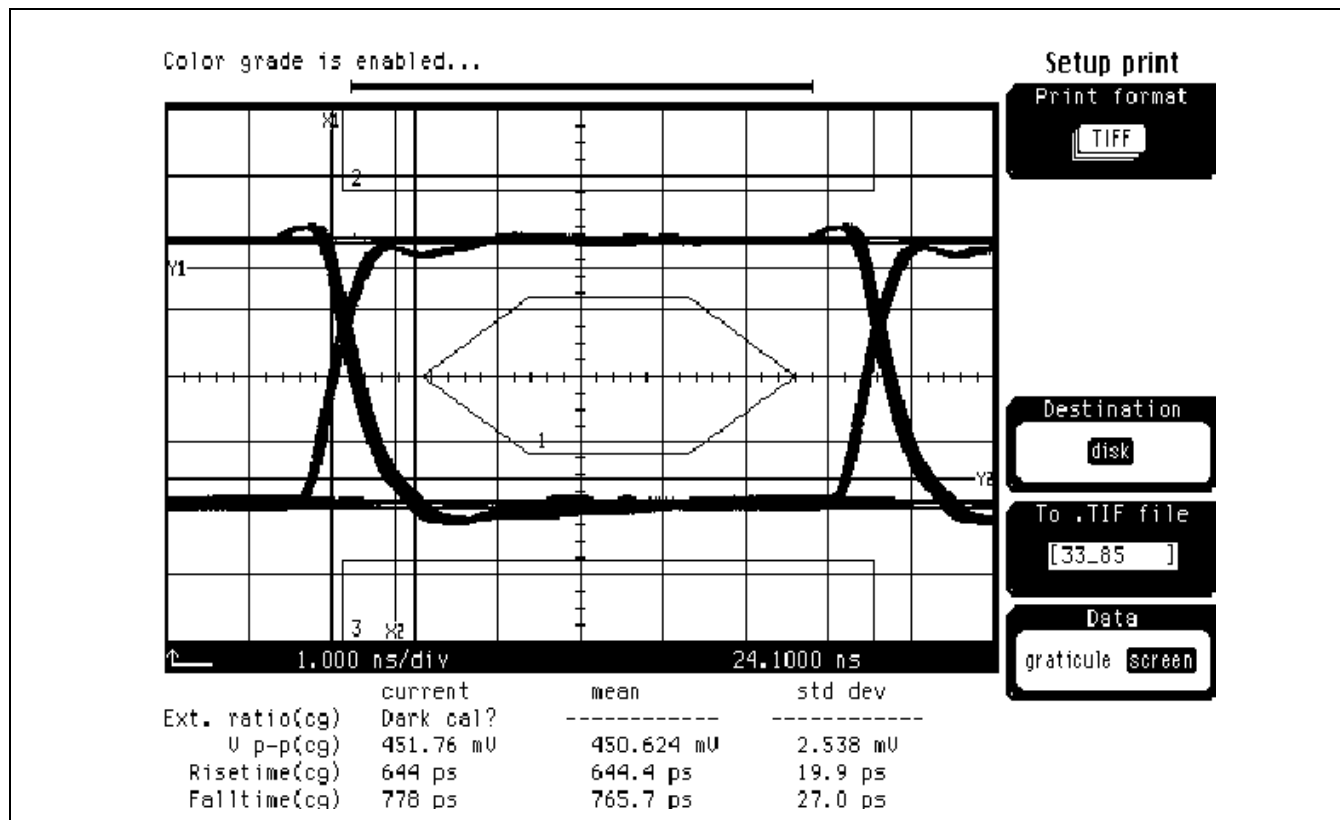

Preliminary Information



# 4.0 Applications Information

## 4.1 Typical Applications Circuit

Figure 4-1. Typical Applications Circuit

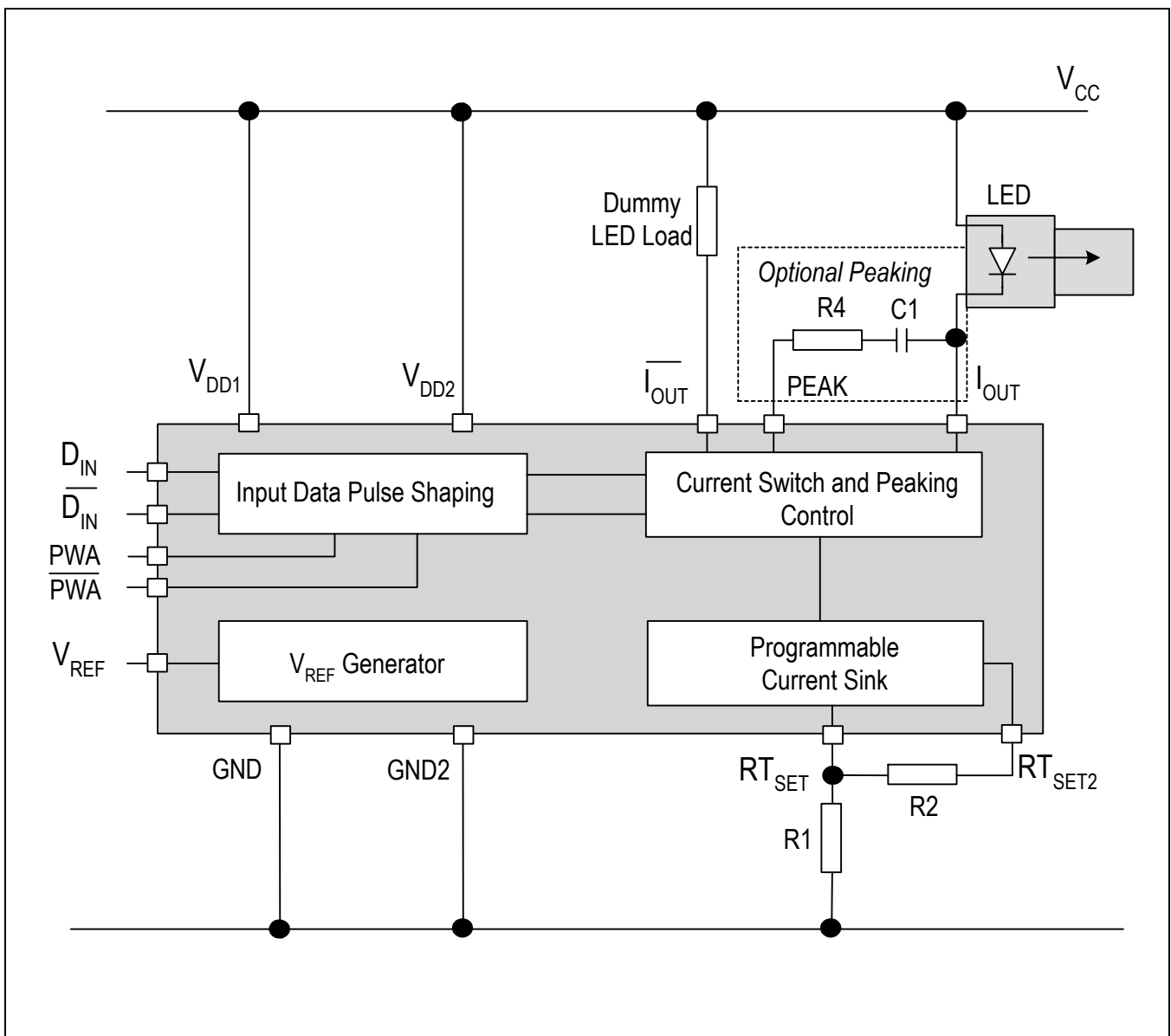

Preliminary Information

## 4.2 Evaluation Board

An electrical evaluation board is available for the MC2042-4. The schematic is shown below.

Figure 4-2. Evaluation Board

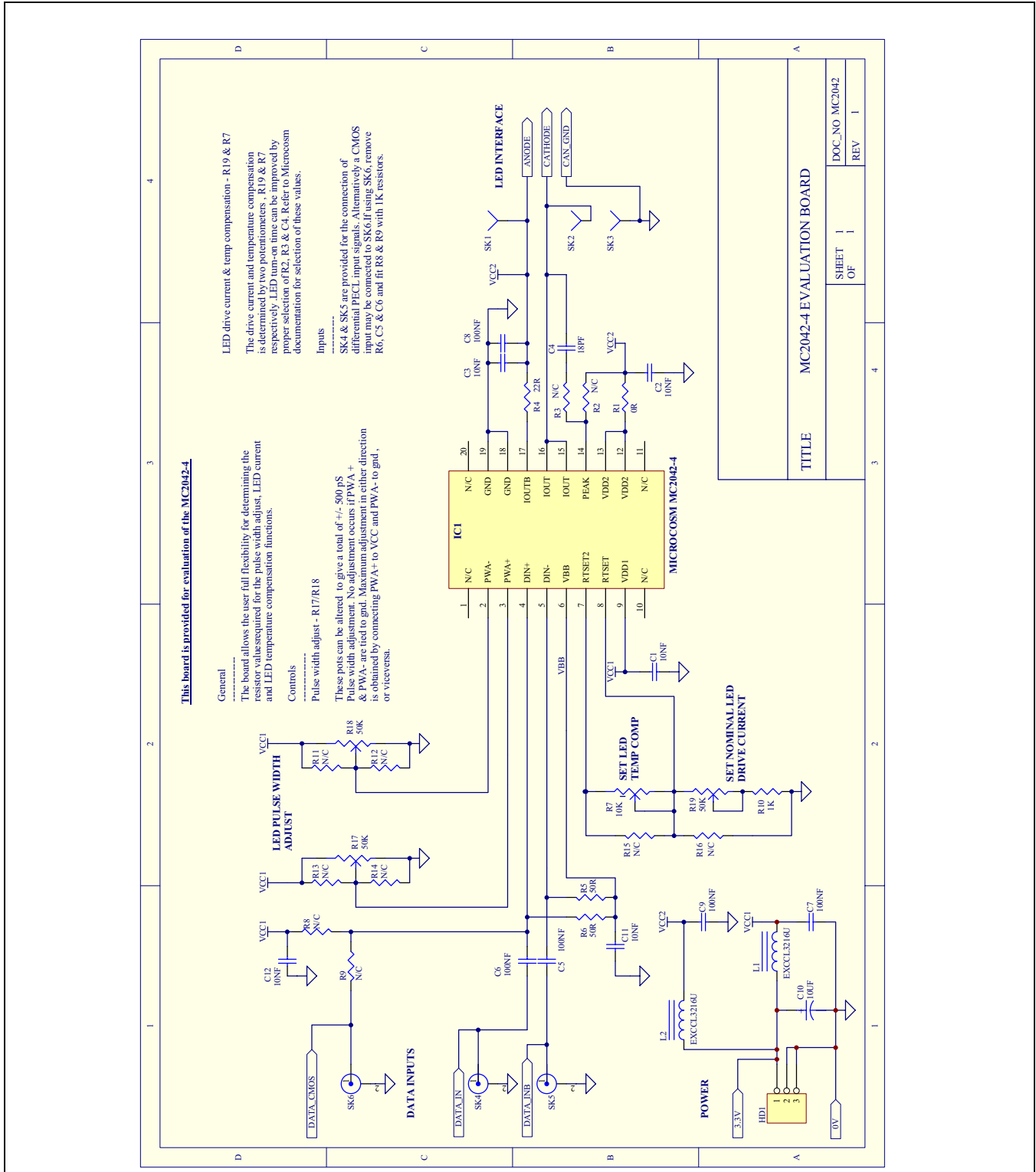

Preliminary Information



# 5.0 Package Specification

Figure 5-1. TSSOP20 Package Information

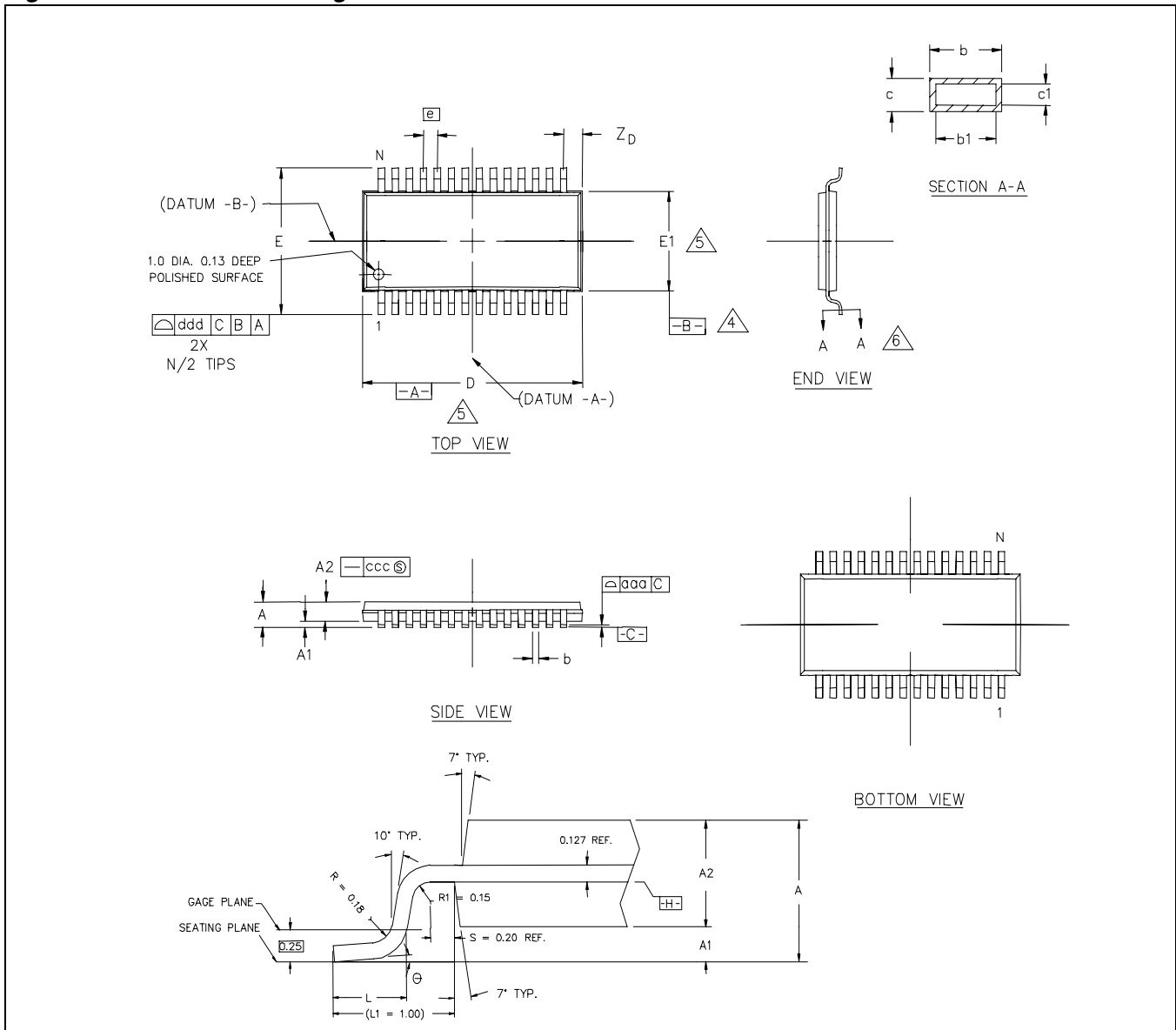

Preliminary Information

**Note:**

This package is available in conventional, lead-free and RoHS-compliant versions. Consult the [Mindspeed.com](http://Mindspeed.com) web site for current information.

Figure 5-2. QSOP16 Package Information

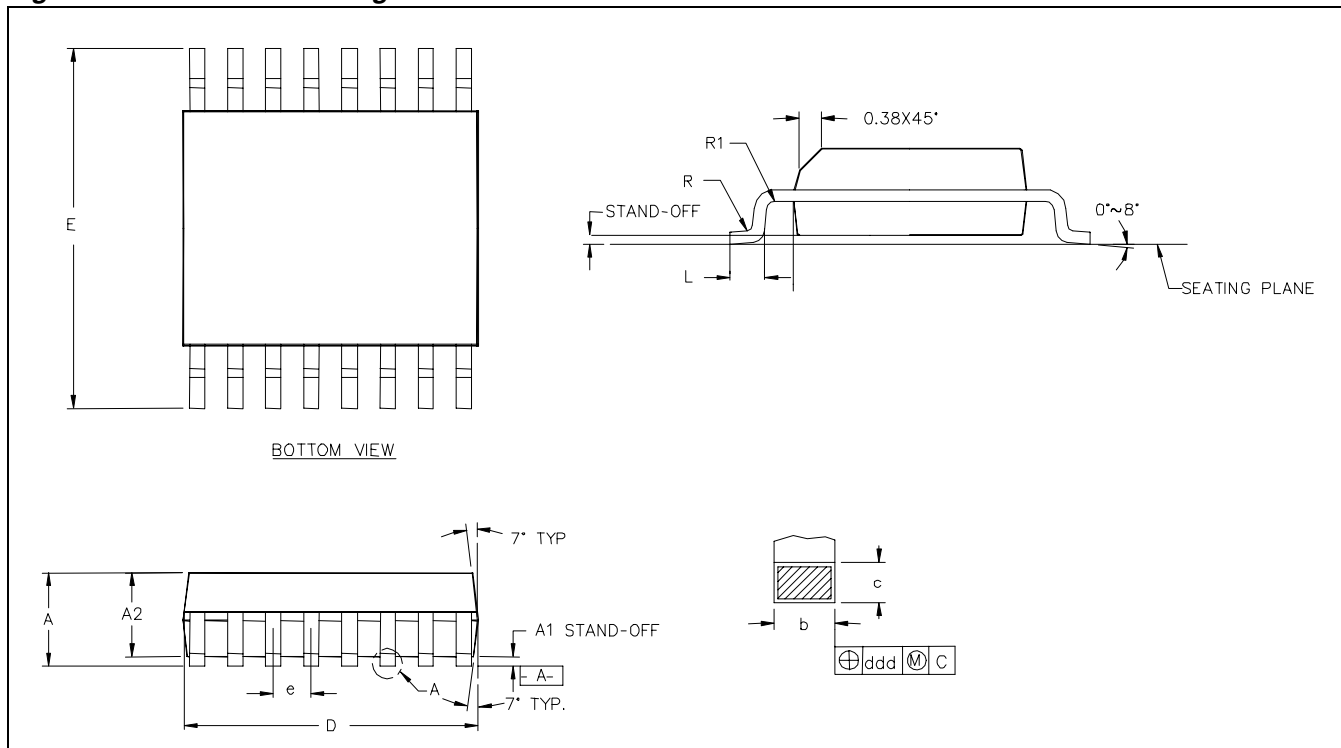

Table 5-1. TSSOP20 Dimensions

Dims.	Tols/leads	TSSOP20L
A	MAX	1.20
A1		0.5MIN/.10MAX.
A2	NOM	.90
D	±.05	6.50
E	±.10	6.40
E1	±.10	4.40
L	+ .15/- .10	.60
L1	REF.	1.00
Zp	REF.	.325
e	BASIC	.65
b	±.05	.22
c		.13MIN/.20MAX
e	±4°	4°
aaa	MAX.	.10
bbb	MAX.	.10
ccc	MAX	.05
ddd	MAX.	.20

Preliminary Information

**Table 5-2. QSOP16 Dimensions**

<b>Dims.</b>	<b>Tols/N</b>	<b>QSOP16</b>
A	MAX.	1.60
A1	±.05	0.1
A2	±.10	1.40
D	±.10	4.9
E	±.20	6.00
E1	±.10	3.90
L	±.05	0.6
ccc	MAX.	0.10
ddd	MAX.	0.10
e	BASIC	0.65
b	±.05	0.25
c	±.05	.2 Min. .24 Max.
R	±.05	0.20
R1	Min.	0.20

Preliminary Information

© 2005, Mindspeed Technologies, Inc. All rights reserved.

Information in this document is provided in connection with Mindspeed Technologies™ ("Mindspeed™") products. These materials are provided by Mindspeed as a service to its customers and may be used for informational purposes only. Except as provided in Mindspeed's Terms and Conditions of Sale for such products or in any separate agreement related to this document, Mindspeed assumes no liability whatsoever. Mindspeed assumes no responsibility for errors or omissions in these materials. Mindspeed may make changes to specifications and product descriptions at any time, without notice. Mindspeed makes no commitment to update the information and shall have no responsibility whatsoever for conflicts or incompatibilities arising from future changes to its specifications and product descriptions. No license, express or implied, by estoppel or otherwise, to any intellectual property rights is granted by this document.

THESE MATERIALS ARE PROVIDED "AS IS" WITHOUT WARRANTY OF ANY KIND, EITHER EXPRESS OR IMPLIED, RELATING TO SALE AND/OR USE OF MINDSPEED PRODUCTS INCLUDING LIABILITY OR WARRANTIES RELATING TO FITNESS FOR A PARTICULAR PURPOSE, CONSEQUENTIAL OR INCIDENTAL DAMAGES, MERCHANTABILITY, OR INFRINGEMENT OF ANY PATENT, COPYRIGHT OR OTHER INTELLECTUAL PROPERTY RIGHT. MINDSPEED FURTHER DOES NOT WARRANT THE ACCURACY OR COMPLETENESS OF THE INFORMATION, TEXT, GRAPHICS OR OTHER ITEMS CONTAINED WITHIN THESE MATERIALS. MINDSPEED SHALL NOT BE LIABLE FOR ANY SPECIAL, INDIRECT, INCIDENTAL, OR CONSEQUENTIAL DAMAGES, INCLUDING WITHOUT LIMITATION, LOST REVENUES OR LOST PROFITS, WHICH MAY RESULT FROM THE USE OF THESE MATERIALS.

Mindspeed products are not intended for use in medical, lifesaving or life sustaining applications. Mindspeed customers using or selling Mindspeed products for use in such applications do so at their own risk and agree to fully indemnify Mindspeed for any damages resulting from such improper use or sale.

**[www.mindspeed.com](http://www.mindspeed.com)**

General Information:  
(949) 579-3327  
Headquarters - Newport Beach  
4000 MacArthur Blvd., East Tower  
Newport Beach, CA. 92660

Preliminary Information

## Looking for pricing, stock, or lifecycle information?

Click below to explore more details on WIN SOURCE:

- ⊖ [View M02042G-4D03-T on WIN SOURCE](#)
- ⊖ [M/A-Com Technology Solutions Information](#)

## Optimize Your Supply Chain with WIN SOURCE Solutions

- ✓ Global Sourcing Solution
- ✓ Obsolete Management
- ✓ Cost Control Management
- ✓ Shortage Management
- ✓ Alternative Solution
- ✓ Excess Inventory Management