



**THE DATASHEET OF
LZ9-M0CW00-0055**



High Luminous Efficacy
Cool White LED Emitter

LZ9-00CW00



Key Features

- High Luminous Efficacy, Cool White LED
- CRI 70 minimum
- Can dissipate up to 20W
- Ultra-small foot print – 7.0mm x 7.0mm
- Surface mount ceramic package with integrated glass lens
- Low Thermal Resistance (1.3°C/W)
- Very high Luminous Flux density
- JEDEC Level 1 for Moisture Sensitivity Level
- Autoclave complaint (JEDEC JESD22-A102-C)
- Lead (Pb) free and RoHS compliant
- Reflow solderable (up to 6 cycles)
- Emitter available on MCPCB (optional)
- Full suite of TIR secondary optics family available

Part Number Options

Base part number

| Part number | Description |
|-----------------|--|
| LZ9-00CW00-xxxx | 9-die emitter CRI 70 minimum |
| LZ9-J0CW00-xxxx | 9-die emitter CRI 70 minimum on Star MCPCB in 1x9 electrical configuration |
| LZ9-M0CW00-xxxx | 9-die emitter CRI 70 minimum on Star MCPCB in 3x3 electrical configuration |

Bin Kit Option Codes

| CW, Cool-White (5000K- 5500K - 6500K) | | | |
|---------------------------------------|--------------|--|--|
| Kit number suffix | Min flux Bin | Color Bin Ranges | Description |
| 0055 | Y | 2U, 2Y, 3U, 2A, 2D, 3A, 2B, 2C, 3B, 2V, 2X, 3V | full distribution flux; 5500K bin (1.5 ANSI) |
| 0065 | Y | 1U, 1A, 1B, 1V, 1Y, 1D, 1C, 1X, 2U, 2A, 2B, 2V | full distribution flux; 6500K bin (1.5 ANSI) |

Cool White Chromaticity Groups

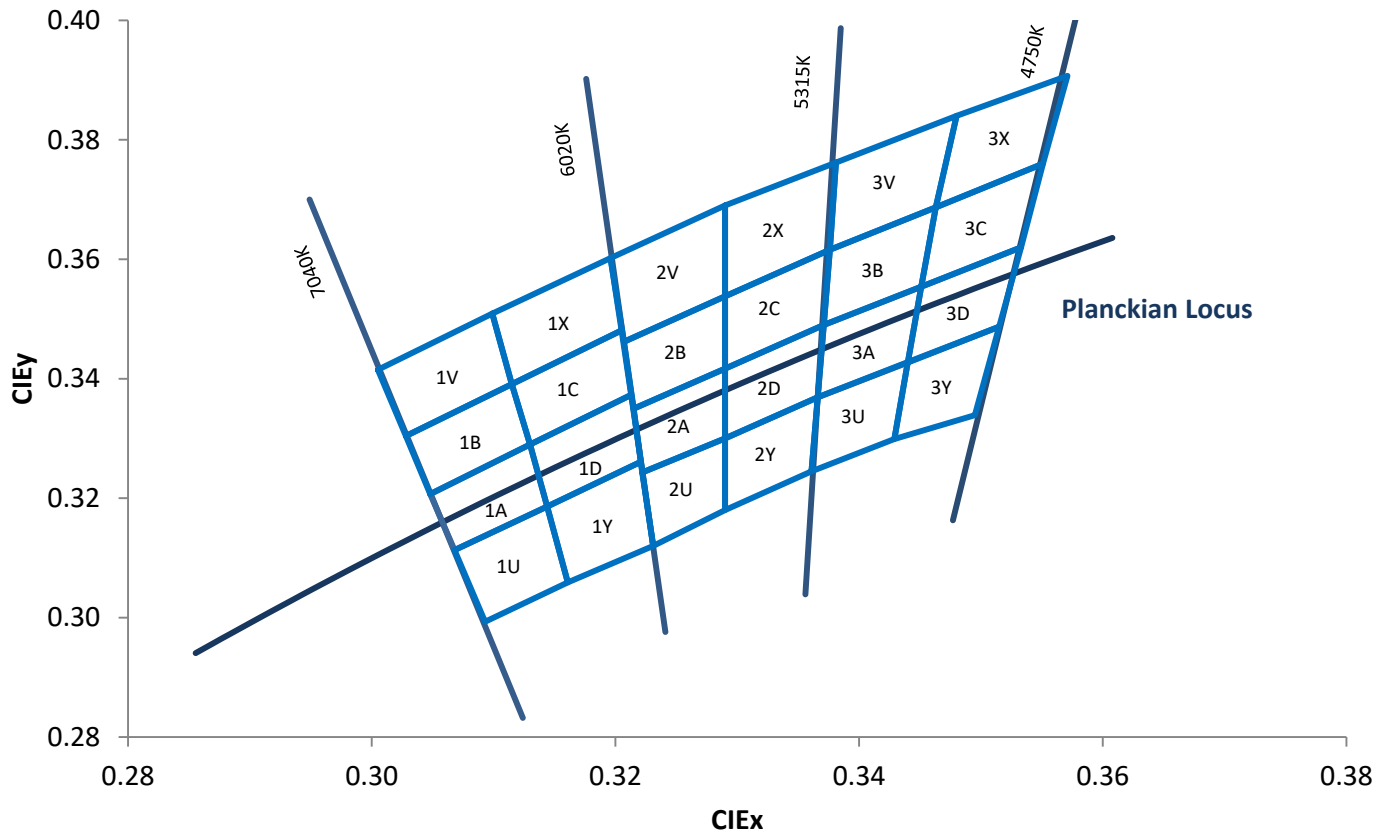

Standard Chromaticity Groups plotted on excerpt from the CIE 1931 (2°) x-y Chromaticity Diagram. Coordinates are listed below in the table.

Cool White Bin Coordinates

| Bin code | CIE _x | CIE _y | Bin code | CIE _x | CIE _y | Bin code | CIE _x | CIE _y | Bin code | CIE _x | CIE _y |
|----------|------------------|------------------|----------|------------------|------------------|----------|------------------|------------------|----------|------------------|------------------|
| 1U | 0.3068 | 0.3113 | 1A | 0.3048 | 0.3207 | 1B | 0.3028 | 0.3304 | 1V | 0.3005 | 0.3415 |
| | 0.3144 | 0.3186 | | 0.313 | 0.329 | | 0.3115 | 0.3391 | | 0.3099 | 0.3509 |
| | 0.3161 | 0.3059 | | 0.3144 | 0.3186 | | 0.313 | 0.329 | | 0.3115 | 0.3391 |
| | 0.3093 | 0.2993 | | 0.3068 | 0.3113 | | 0.3048 | 0.3207 | | 0.3028 | 0.3304 |
| | 0.3068 | 0.3113 | | 0.3048 | 0.3207 | | 0.3028 | 0.3304 | | 0.3005 | 0.3415 |
| 1Y | 0.3144 | 0.3186 | 1D | 0.313 | 0.329 | 1C | 0.3115 | 0.3391 | 1X | 0.3099 | 0.3509 |
| | 0.3221 | 0.3261 | | 0.3213 | 0.3373 | | 0.3205 | 0.3481 | | 0.3196 | 0.3602 |
| | 0.3231 | 0.312 | | 0.3221 | 0.3261 | | 0.3213 | 0.3373 | | 0.3205 | 0.3481 |
| | 0.3161 | 0.3059 | | 0.3144 | 0.3186 | | 0.313 | 0.329 | | 0.3115 | 0.3391 |
| | 0.3144 | 0.3186 | | 0.313 | 0.329 | | 0.3115 | 0.3391 | | 0.3099 | 0.3509 |
| 2U | 0.3222 | 0.3243 | 2A | 0.3215 | 0.335 | 2B | 0.3207 | 0.3462 | 2V | 0.3196 | 0.3602 |
| | 0.329 | 0.33 | | 0.329 | 0.3417 | | 0.329 | 0.3538 | | 0.329 | 0.369 |
| | 0.329 | 0.318 | | 0.329 | 0.33 | | 0.329 | 0.3417 | | 0.329 | 0.3538 |
| | 0.3231 | 0.312 | | 0.3222 | 0.3243 | | 0.3215 | 0.335 | | 0.3207 | 0.3462 |
| | 0.3222 | 0.3243 | | 0.3215 | 0.335 | | 0.3207 | 0.3462 | | 0.3196 | 0.3602 |
| 2Y | 0.329 | 0.33 | 2D | 0.329 | 0.3417 | 2C | 0.329 | 0.3538 | 2X | 0.329 | 0.369 |
| | 0.3366 | 0.3369 | | 0.3371 | 0.349 | | 0.3376 | 0.3616 | | 0.3381 | 0.3762 |
| | 0.3361 | 0.3245 | | 0.3366 | 0.3369 | | 0.3371 | 0.349 | | 0.3376 | 0.3616 |
| | 0.329 | 0.318 | | 0.329 | 0.33 | | 0.329 | 0.3417 | | 0.329 | 0.3538 |
| | 0.329 | 0.33 | | 0.329 | 0.3417 | | 0.329 | 0.3538 | | 0.329 | 0.369 |
| 3U | 0.3366 | 0.3369 | 3A | 0.3371 | 0.349 | 3B | 0.3376 | 0.3616 | 3V | 0.3381 | 0.3762 |
| | 0.344 | 0.3428 | | 0.3451 | 0.3554 | | 0.3463 | 0.3687 | | 0.348 | 0.384 |
| | 0.3429 | 0.3299 | | 0.344 | 0.3427 | | 0.3451 | 0.3554 | | 0.3463 | 0.3687 |
| | 0.3361 | 0.3245 | | 0.3366 | 0.3369 | | 0.3371 | 0.349 | | 0.3376 | 0.3616 |
| | 0.3366 | 0.3369 | | 0.3371 | 0.349 | | 0.3376 | 0.3616 | | 0.3381 | 0.3762 |
| 3Y | 0.344 | 0.3428 | 3D | 0.3451 | 0.3554 | 3C | 0.3463 | 0.3687 | 3X | 0.348 | 0.384 |
| | 0.3515 | 0.3487 | | 0.3533 | 0.362 | | 0.3551 | 0.376 | | 0.3571 | 0.3907 |
| | 0.3495 | 0.3339 | | 0.3515 | 0.3487 | | 0.3533 | 0.362 | | 0.3551 | 0.376 |
| | 0.3429 | 0.3299 | | 0.344 | 0.3427 | | 0.3451 | 0.3554 | | 0.3463 | 0.3687 |
| | 0.344 | 0.3428 | | 0.3451 | 0.3554 | | 0.3463 | 0.3687 | | 0.348 | 0.384 |

Luminous Flux Bins

Table 1:

| Bin Code | Minimum Luminous Flux (Φ_v) @ $I_F = 700\text{mA}$ ^[1,2] (lm) | Maximum Luminous Flux (Φ_v) @ $I_F = 700\text{mA}$ ^[1,2] (lm) |
|----------|--|--|
| Y | 1357 | 1696 |
| Z | 1696 | 2120 |

Notes for Table 1:

1. Luminous flux performance guaranteed within published operating conditions. LED Engin maintains a tolerance of $\pm 10\%$ on flux measurements.

Forward Voltage Range per String

Table 2:

| Bin Code | Minimum Forward Voltage (V_F) @ $I_F = 700\text{mA}$ ^[1,2] (V) | Maximum Forward Voltage (V_F) @ $I_F = 700\text{mA}$ ^[1,2] (V) |
|----------|--|--|
| 0 | 9.0 | 10.8 |

Notes for Table 2:

1. LED Engin maintains a tolerance of $\pm 0.04\text{V}$ for forward voltage measurements.
2. Forward Voltage per string of 3 LED dies in series.

Absolute Maximum Ratings

Table 3:

| Parameter | Symbol | Value | Unit |
|--|-----------|--|-------------|
| DC Forward Current at $T_{jmax}=135^{\circ}C$ ^[1] | I_F | 800 | mA |
| DC Forward Current at $T_{jmax}=150^{\circ}C$ ^[1] | I_F | 700 | mA |
| Peak Pulsed Forward Current ^[2] | I_{FP} | 1000 | mA |
| Reverse Voltage | V_R | See Note 3 | V |
| Storage Temperature | T_{stg} | -40 ~ +150 | $^{\circ}C$ |
| Junction Temperature | T_J | 150 | $^{\circ}C$ |
| Soldering Temperature ^[4] | T_{sol} | 260 | $^{\circ}C$ |
| Allowable Reflow Cycles | | 6 | |
| Autoclave Conditions ^[5] | | 121 $^{\circ}C$ at 2 ATM, 100% RH for 168 hours | |
| ESD Sensitivity ^[6] | | > 8,000 V HBM Class 3B JESD22-A114-D | |

Notes for Table 3:

- Maximum DC forward current (per die) is determined by the overall thermal resistance and ambient temperature. Follow the curves in Figure 10 for current de-rating.
- Pulse forward current conditions: Pulse Width \leq 10msec and Duty Cycle \leq 10%.
- LEDs are not designed to be reverse biased.
- Solder conditions per JEDEC 020c. See Reflow Soldering Profile Figure 3.
- Autoclave Conditions per JEDEC JESD22-A102-C.
- LED Engin recommends taking reasonable precautions towards possible ESD damages and handling the LZ9-00CW00 in an electrostatic protected area (EPA). An EPA may be adequately protected by ESD controls as outlined in ANSI/ESD S6.1.

Optical Characteristics @ $T_C = 25^{\circ}C$

Table 4:

| Parameter | Symbol | Typical | Unit |
|---|-----------------|---------|---------|
| Luminous Flux (@ $I_F = 700mA$) ^[1] | Φ_v | 1800 | lm |
| Luminous Efficacy (@ $I_F = 350mA$) | | 106 | lm/W |
| Correlated Color Temperature | CCT | 5500 | K |
| Color Rendering Index (CRI) | R_a | 75 | |
| Viewing Angle ^[2] | $2\theta_{1/2}$ | 110 | Degrees |
| Total Included Angle ^[3] | $\theta_{0.9}$ | 135 | Degrees |

Notes for Table 4:

- Luminous flux typical value is for all 9 LED dies operating concurrently at rated current.
- Viewing Angle is the off axis angle from emitter centerline where the luminous intensity is $1/2$ of the peak value.
- Total Included Angle is the total angle that includes 90% of the total luminous flux.

Electrical Characteristics @ $T_C = 25^{\circ}C$

Table 5:

| Parameter | Symbol | Typical | Unit |
|---|---------------------------|---------|-----------------|
| Forward Voltage per String (@ $I_F = 700mA$) | V_F | 9.7 | V |
| Temperature Coefficient of Forward Voltage (per String) | $\Delta V_F / \Delta T_J$ | -6.0 | mV/ $^{\circ}C$ |
| Thermal Resistance (Junction to Case) | $R\theta_{J-C}$ | 1.3 | $^{\circ}C/W$ |

IPC/JEDEC Moisture Sensitivity Level

Table 6 - IPC/JEDEC J-STD-20 MSL Classification:

| Level | Floor Life | | Soak Requirements | | | |
|-------|------------|-------------------|-------------------|-----------------|------------|------------|
| | Time | Conditions | Standard | Accelerated | Time (hrs) | Conditions |
| 1 | Unlimited | ≤ 30°C/ 85% RH | 168 +5/-0 | 85°C/ 85% RH | n/a | n/a |

Notes for Table 1:

- The standard soak time is the sum of the default value of 24 hours for the semiconductor manufacturer's exposure time (MET) between bake and bag and the floor life of maximum time allowed out of the bag at the end user of distributor's facility.

Average Lumen Maintenance Projections

Lumen maintenance generally describes the ability of a lamp to retain its output over time. The useful lifetime for solid state lighting devices (Power LEDs) is also defined as Lumen Maintenance, with the percentage of the original light output remaining at a defined time period.

Based on accelerated lifetime testing, LED Engin projects that the LZ Series will deliver, on average, 70% Lumen Maintenance at 65,000 hours of operation at a forward current of 700 mA per die. This projection is based on constant current operation with junction temperature maintained at or below 120°C.

Mechanical Dimensions (mm)

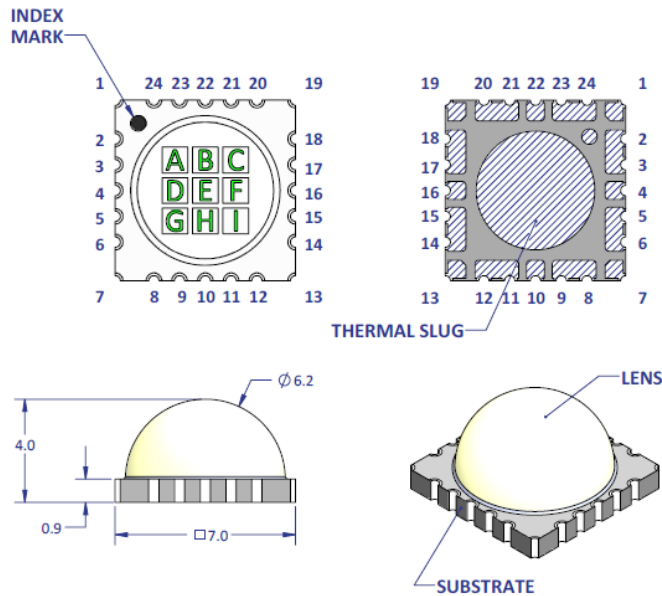

Figure 1: Package outline drawing.

Notes for Figure 1:

1. Index mark indicates case temperature measurement point.
2. Unless otherwise noted, the tolerance = ± 0.20 mm.

| Emitter pin layout | | | |
|--|-------------|-----|-------|
| Emitter channel | Emitter pin | Die | Color |
| Ch1 - | 23, 24 | E | White |
| Ch1 | | B | White |
| Ch1 + | 17, 18 | A | White |
| Ch2 - | 2, 3 | G | White |
| Ch2 | | I | White |
| Ch2 + | 14, 15 | C | White |
| Ch3 - | 5, 6 | D | White |
| Ch3 | | H | White |
| Ch3+ | 11, 12 | F | White |
| NC pins: 1, 4, 7, 8, 9, 10, 13, 16, 19, 20, 21, 22 | | | |
| DNC pins: none | | | |

Notes:

- NC = Not internally Connected (Electrically isolated)
DNC = Do Not Connect (Electrically Non isolated)

Recommended Solder Pad Layout (mm)

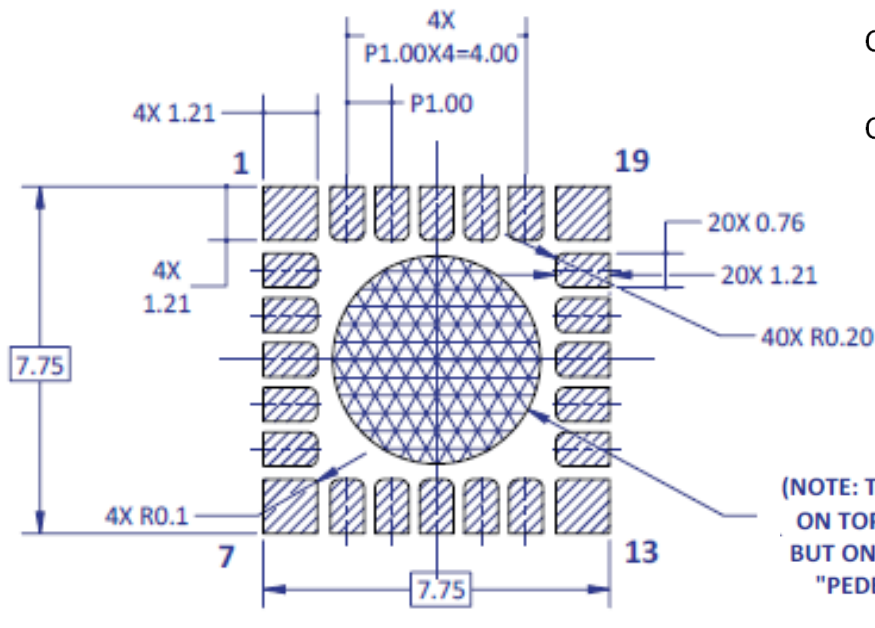
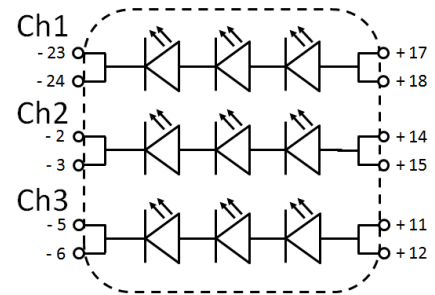

Figure 2a: Recommended solder pad layout for anode, cathode, and thermal pad.

Note for Figure 2a:

1. Unless otherwise noted, the tolerance = ± 0.20 mm.
2. LED Engin recommends the use of pedestal MCPCB's which allow the emitter thermal slug to be soldered directly to the metal core of the MCPCB. Such MCPCB technologies eliminate the high thermal resistance dielectric layer that standard MCPCB technologies use in between the emitter thermal slug and the metal core of the MCPCB, thus lowering the overall system thermal resistance.
3. LED Engin recommends x-ray sample monitoring for solder voids underneath the emitter thermal slug. The total area covered by solder voids should be less than 20% of the total emitter thermal slug area. Excessive solder voids will increase the emitter to MCPCB thermal resistance and may lead to higher failure rates due to thermal over stress.



$\phi 4.65$
(NOTE: THIS LAND IS NOT ON TOP METAL LAYER, BUT ON SOLID LAYER IN "PEDESTAL" BOARD DESIGN)

Recommended Solder Mask Layout (mm)

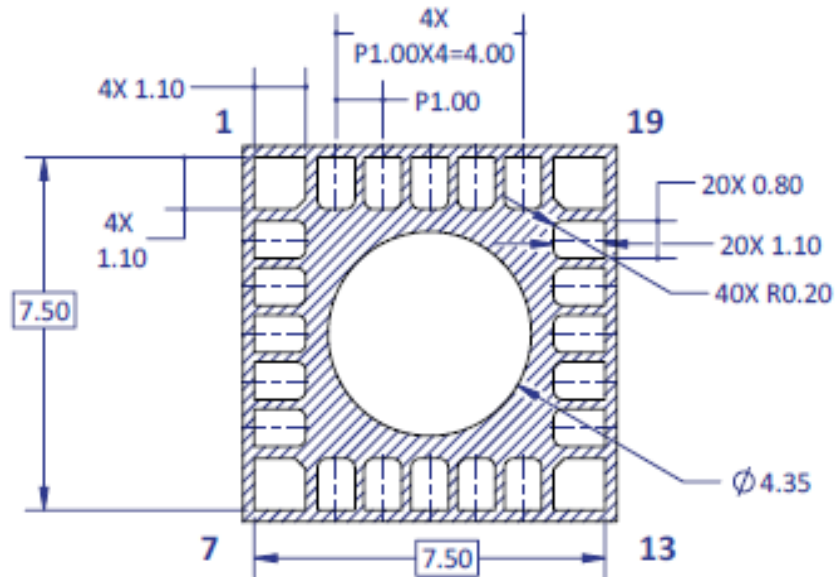

Figure 2b: Recommended solder mask opening (hatched area) for anode, cathode, and thermal pad.

Note for Figure 2b:

1. Unless otherwise noted, the tolerance = ± 0.20 mm.

Recommended 8mil Stencil Apertures Layout (mm)

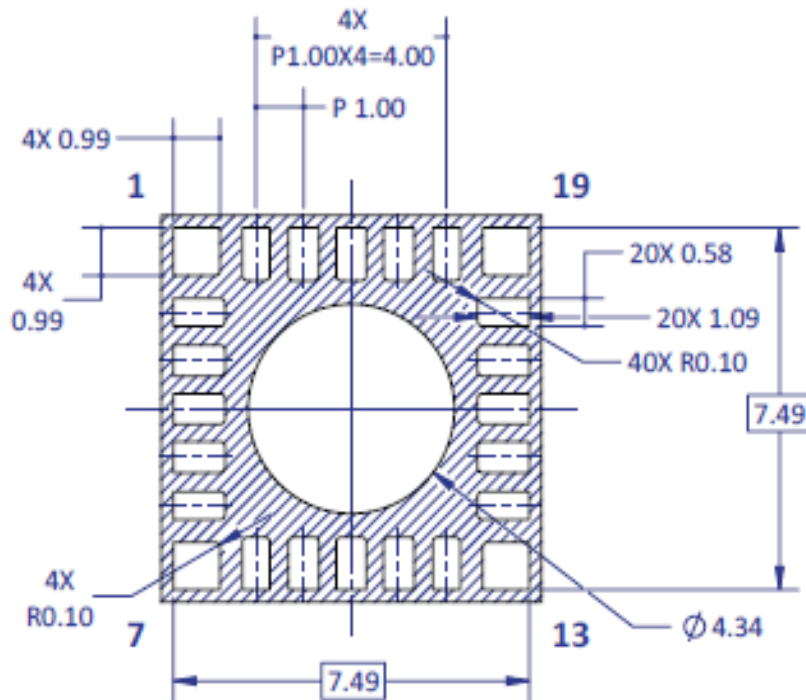

Figure 2c: Recommended 8mil stencil apertures layout for anode, cathode, and thermal pad.

Note for Figure 2c:

1. Unless otherwise noted, the tolerance = ± 0.20 mm.

Reflow Soldering Profile

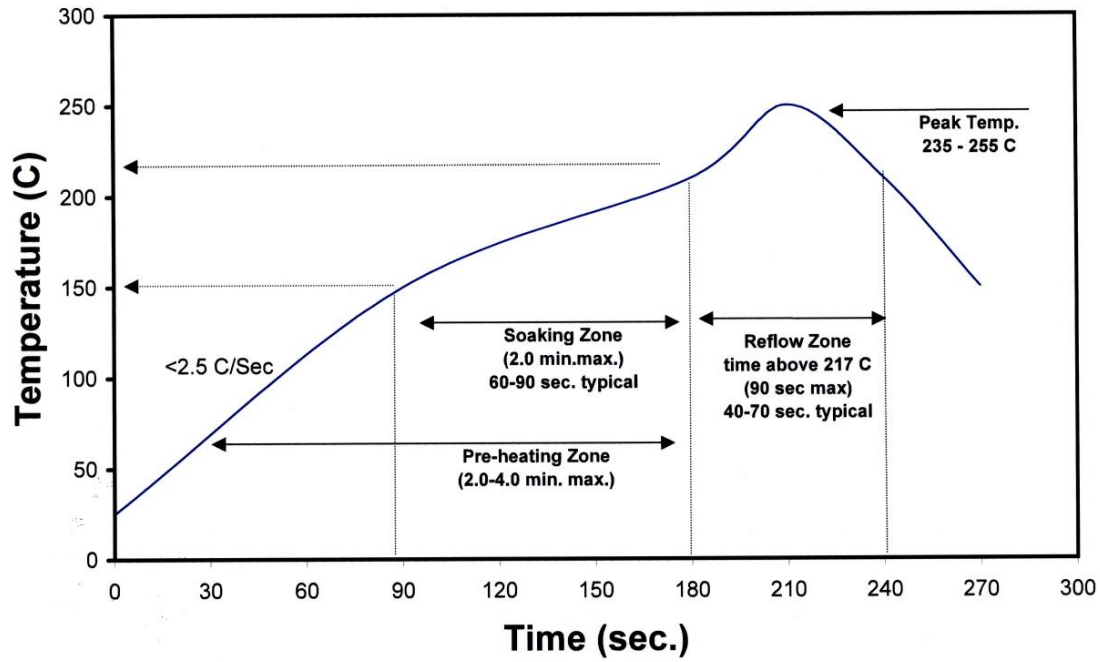

Figure 3: Reflow soldering profile for lead free soldering.

Typical Radiation Pattern

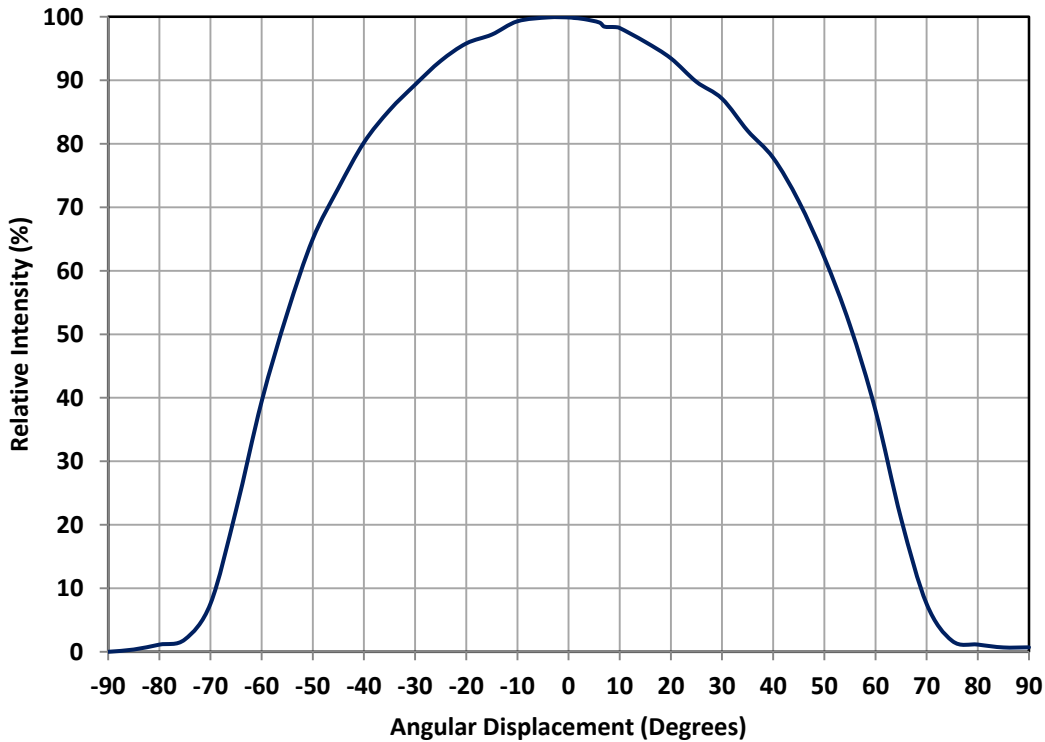

Figure 4: Typical representative spatial radiation pattern.

Typical Relative Spectral Power Distribution

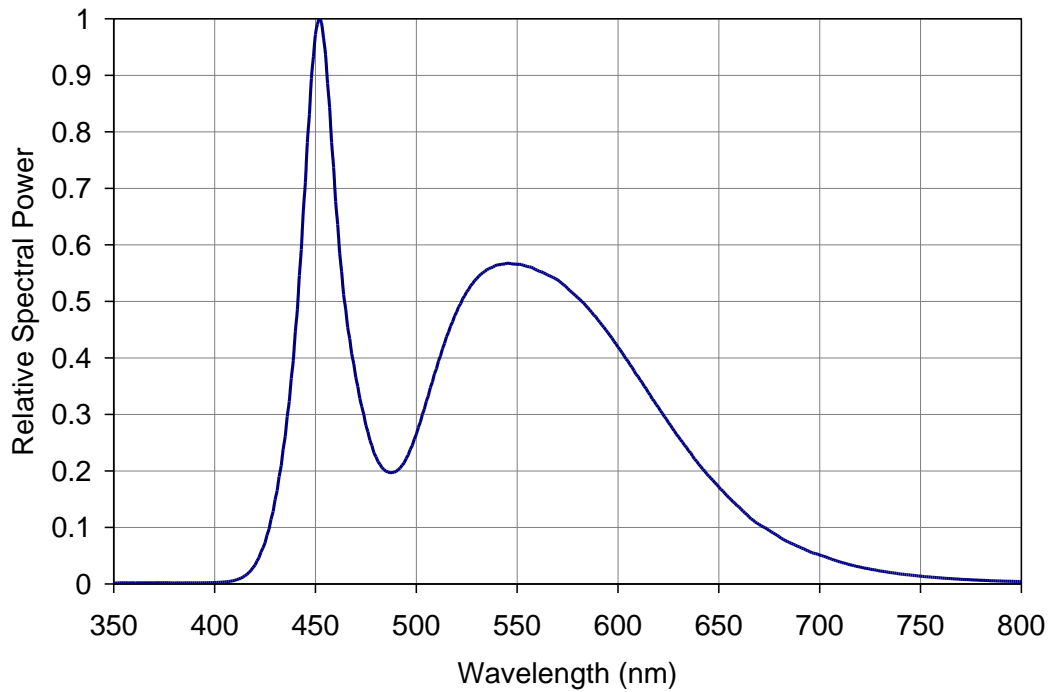

Figure 5: Typical relative spectral power vs. wavelength @ $T_c = 25^\circ\text{C}$

Typical Chromaticity Coordinate Shift over Temperature

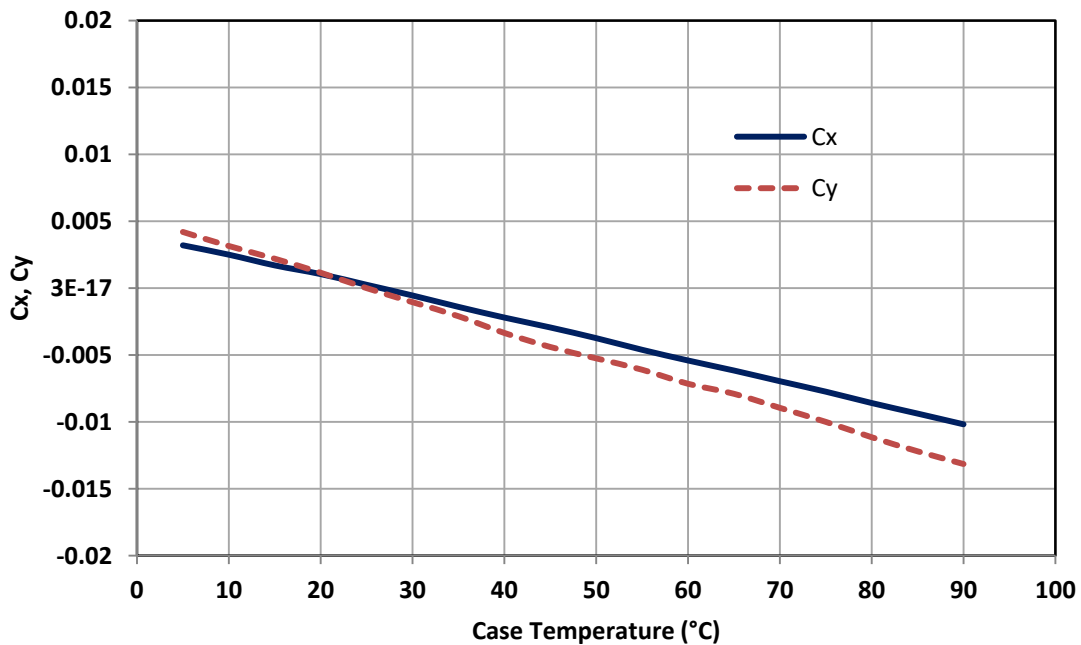

Figure 6: Typical dominant wavelength shift vs. Case temperature.

Typical Relative Light Output

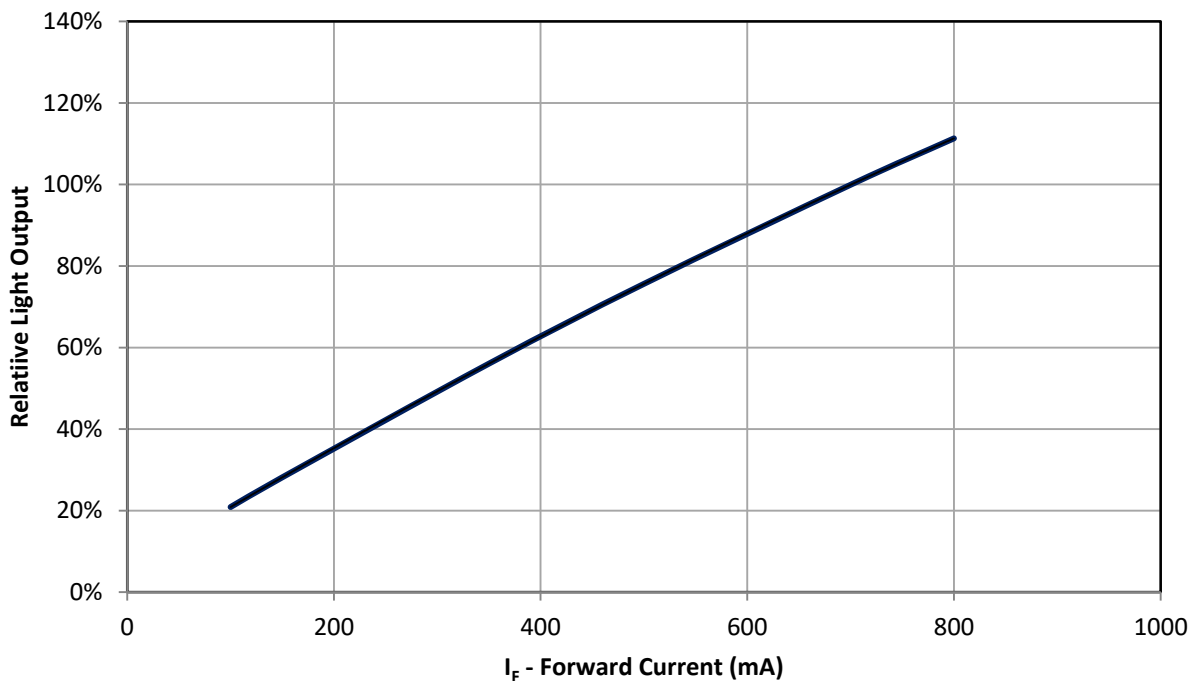

Figure 7: Typical relative light output vs. forward current @ $T_c = 25^\circ\text{C}$.

Typical Normalized Radiant Flux over Temperature

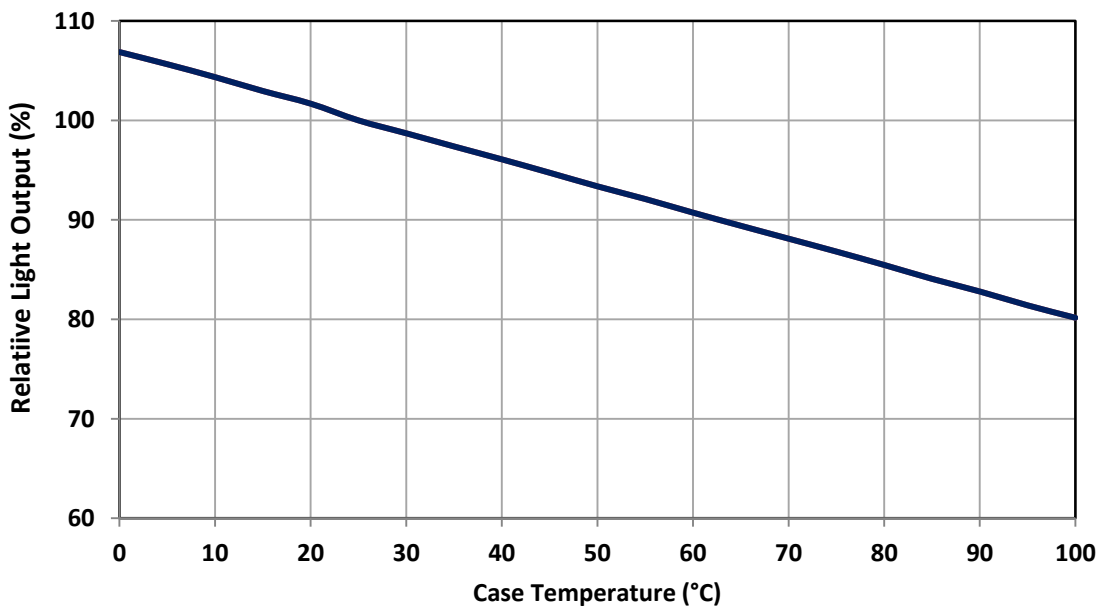

Figure 8: Typical relative light output vs. case temperature.

Typical Forward Voltage Characteristics per String

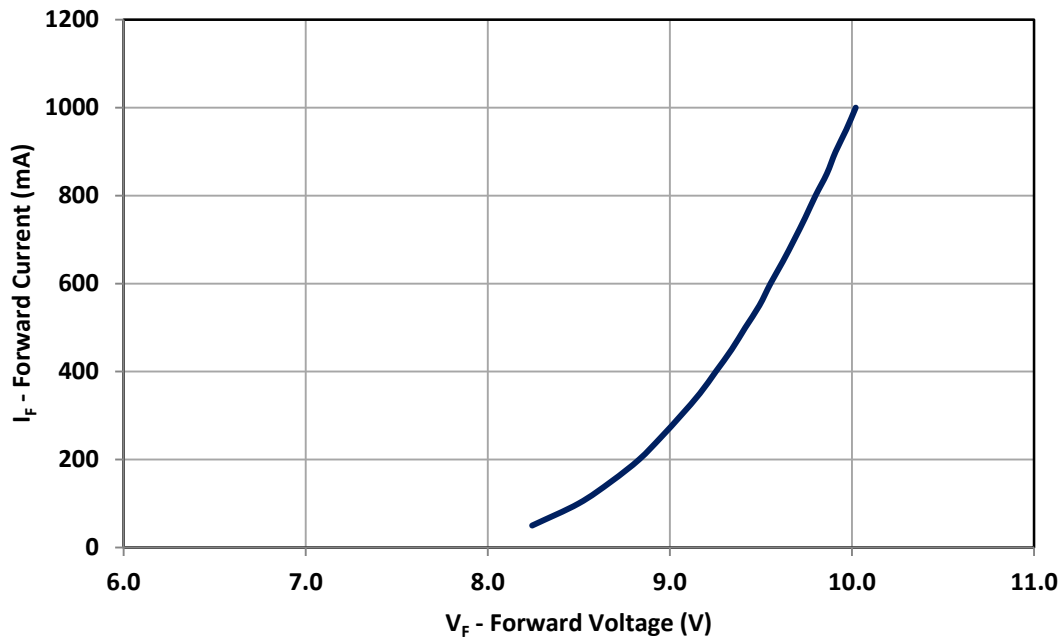

Figure 9: Typical forward current vs. forward voltage¹ @ $T_c = 25^\circ\text{C}$.

Note for Figure 9:

1. Forward Voltage per string of 3 LED dies connected in series.

Current De-rating

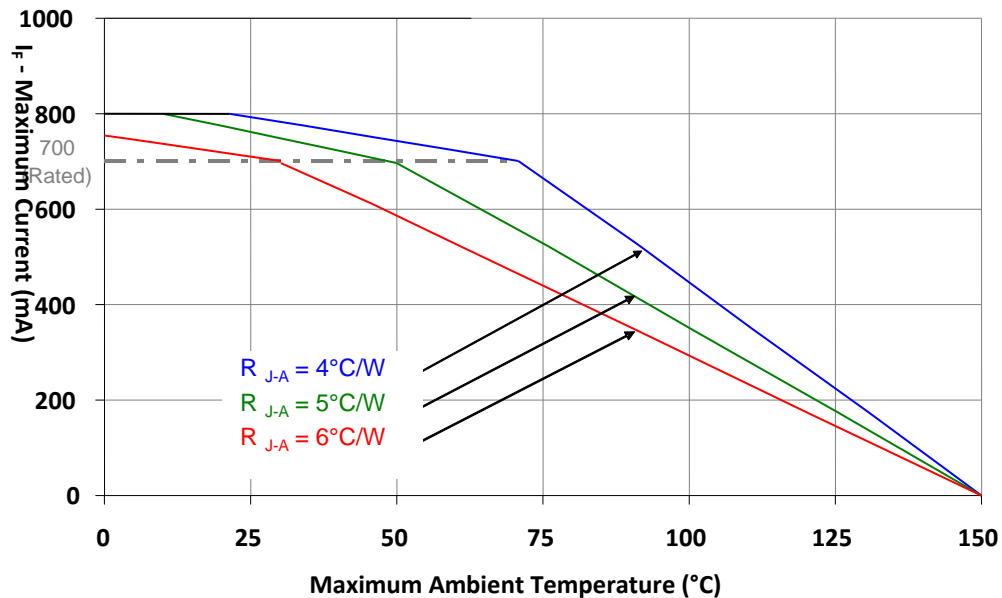

Figure 10: Maximum forward current vs. ambient temperature based on $T_{j(\text{MAX})} = 150^\circ\text{C}$.

Notes for Figure 10:

1. Maximum current assumes that all 9 LED dice are operating concurrently at the same current.
2. RO_{j-c} [Junction to Case Thermal Resistance] for the LZ9-00CW00 is typically 1.3°C/W .
3. RO_{j-a} [Junction to Ambient Thermal Resistance] = $RO_{j-c} + RO_{c-a}$ [Case to Ambient Thermal Resistance].

Emitter Tape and Reel Specifications (mm)

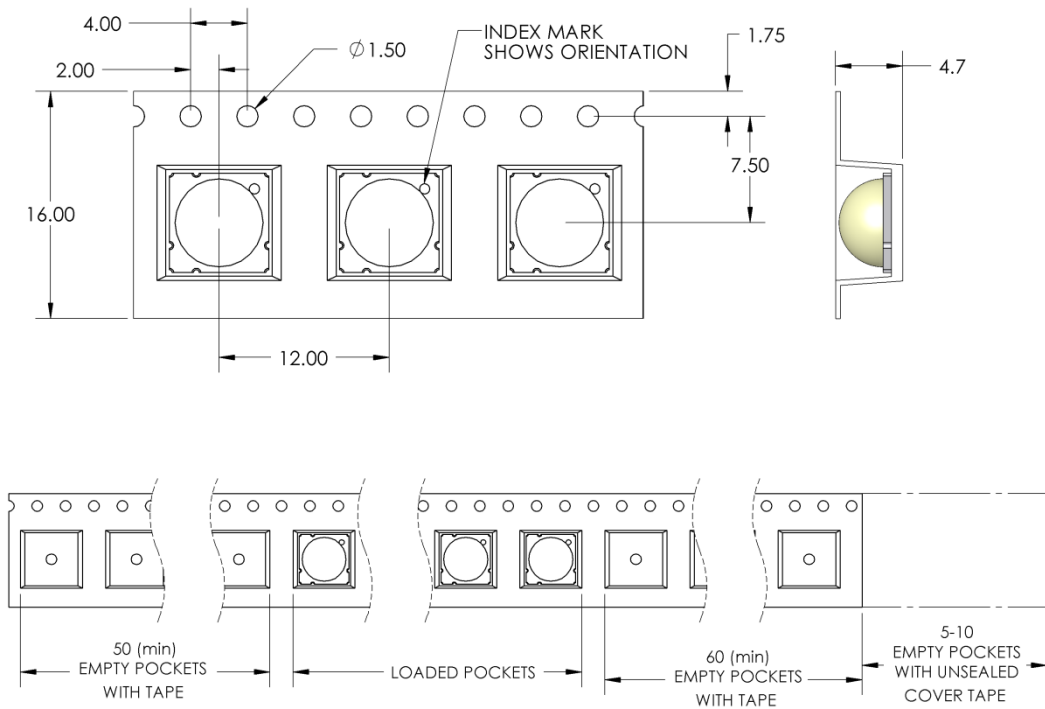

Figure 11: Emitter carrier tape specifications (mm).

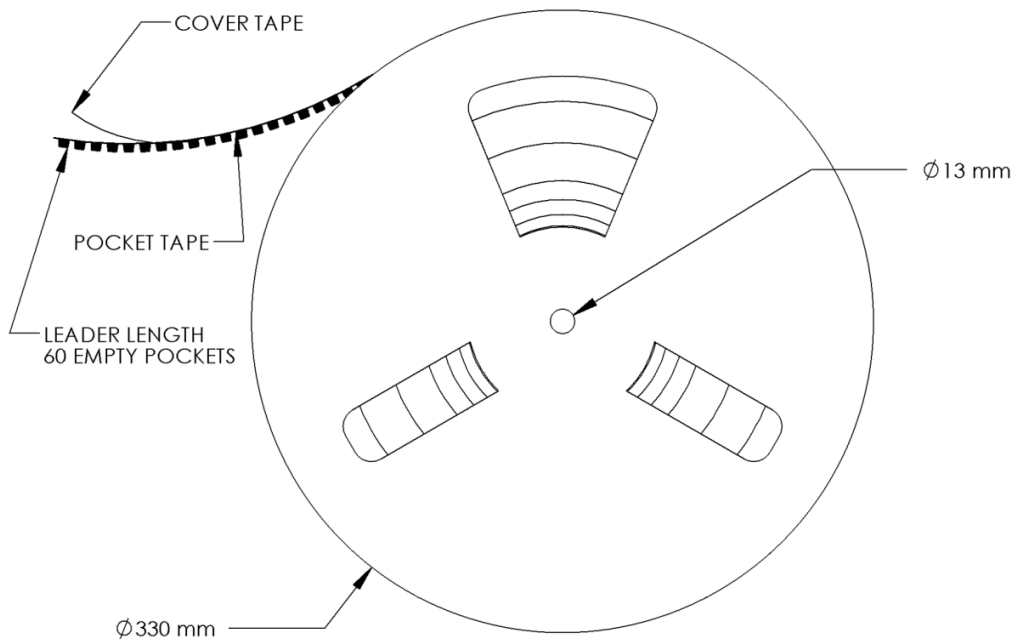

Figure 12: Emitter Reel specifications (mm).

LZ9 MCPCB Family

| Part number | Type of MCPCB | Diameter (mm) | Emitter + MCPCB Thermal Resistance (°C/W) | Typical V_f (V) | Typical I_f (mA) |
|-------------|---------------|---------------|---|-------------------|--------------------|
| LZ9-Jxxxxx | 1-channel | 19.9 | 1.3 + 0.2 = 1.5 | 29.1 | 700 |
| LZ9-Mxxxxx | 3-channel | 19.9 | 1.3 + 0.2 = 1.5 | 9.7/ ch | 700/ ch |

Mechanical Mounting of MCPCB

- MCPCB bending should be avoided as it will cause mechanical stress on the emitter, which could lead to substrate cracking and subsequently LED dies cracking.
- To avoid MCPCB bending:
 - Special attention needs to be paid to the flatness of the heat sink surface and the torque on the screws.
 - Care must be taken when securing the board to the heat sink. This can be done by tightening three M3 screws (or #4-40) in steps and not all the way through at once. Using fewer than three screws will increase the likelihood of board bending.
 - It is recommended to always use plastics washers in combinations with the three screws.
 - If non-taped holes are used with self-tapping screws, it is advised to back out the screws slightly after tightening (with controlled torque) and then re-tighten the screws again.

Thermal interface material

- To properly transfer heat from LED emitter to heat sink, a thermally conductive material is required when mounting the MCPCB on to the heat sink.
- There are several varieties of such material: thermal paste, thermal pads, phase change materials and thermal epoxies. An example of such material is Electrolube EHTC.
- It is critical to verify the material's thermal resistance to be sufficient for the selected emitter and its operating conditions.

Wire soldering

- To ease soldering wire to MCPCB process, it is advised to preheat the MCPCB on a hot plate of 125-150°C. Subsequently, apply the solder and additional heat from the solder iron will initiate a good solder reflow. It is recommended to use a solder iron of more than 60W.
- It is advised to use lead-free, no-clean solder. For example: SN-96.5 AG-3.0 CU 0.5 #58/275 from Kester (pn: 24-7068-7601)

LZ9-Jxxxxx

1 channel, Standard Star MCPCB (1x9) Dimensions (mm)

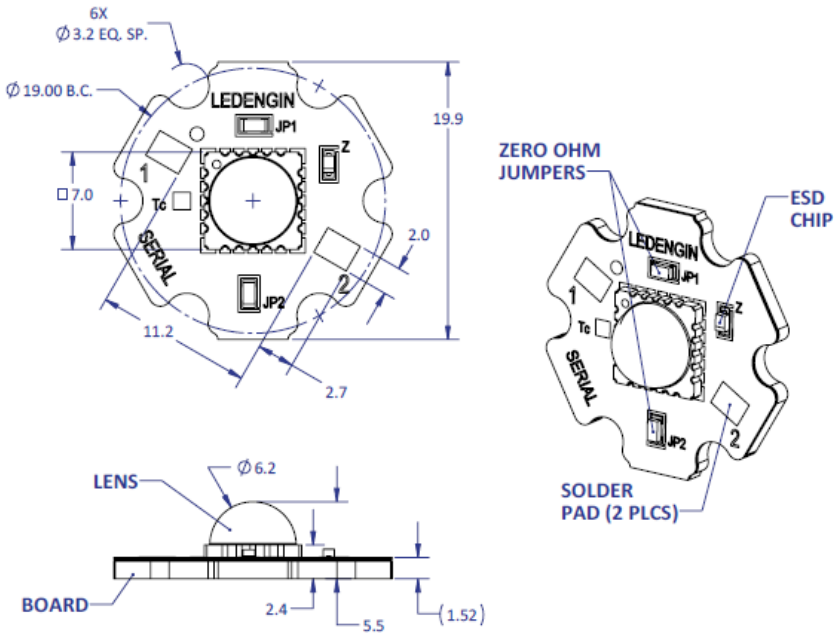

Notes:

- Unless otherwise noted, the tolerance = ± 0.2 mm.
- Slots in MCPCB are for M3 or #4-40 mounting screws.
- LED Engin recommends plastic washers to electrically insulate screws from solder pads and electrical traces.
- LED Engin recommends using thermal interface material when attaching the MCPCB to a heatsink.
- The thermal resistance of the MCPCB is: $R_{\theta C-B}$ 0.2°C/W. This low thermal resistance is possible by utilizing a copper based MCPCB with pedestal design. The emitter thermal slug is in direct contact with the copper core. There are several vendors that offer similar solutions, some of them are: Rayben, Bergquist, SinkPad, Bridge-Semiconductor.

Components used

MCPCB: MHE-301 copper (Rayben)
 ESD chips: BZX585-C47 (NXP, for 9 LED die)
 Jumpers: CRCW06030000Z0 (Vishay)

| Pad layout | | | |
|------------|-----------|------------|-----------|
| Ch. | MCPCB Pad | String/die | Function |
| 1 | 1 | 1/ABCDEF | Cathode - |
| | 2 | GHI | Anode + |

LZ9-Mxxxxx

3 channel, Standard Star MCPCB (3x3) Dimensions (mm)

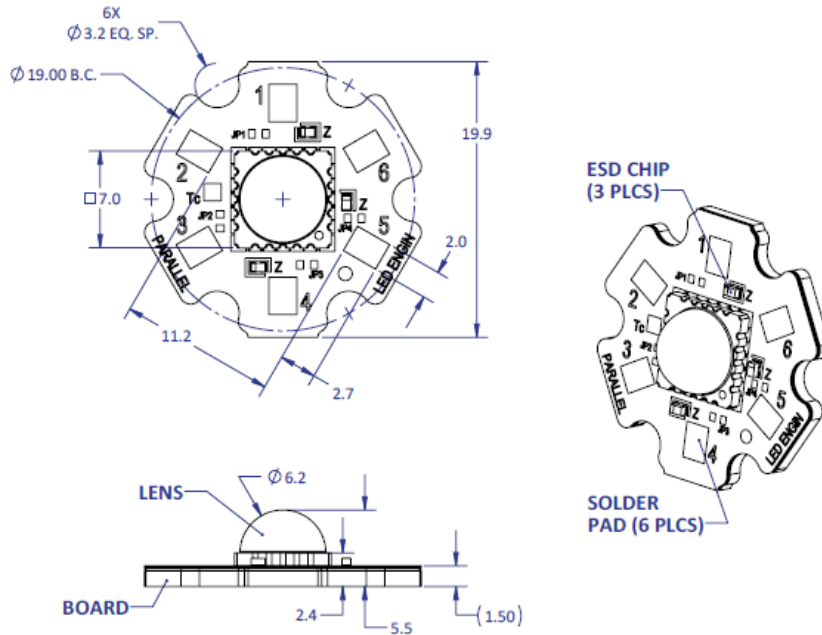

Notes:

- Unless otherwise noted, the tolerance = ± 0.2 mm.
- Slots in MCPCB are for M3 or #4-40 mounting screws.
- LED Engin recommends plastic washers to electrically insulate screws from solder pads and electrical traces.
- LED Engin recommends using thermal interface material when attaching the MCPCB to a heatsink.
- The thermal resistance of the MCPCB is: R_{ΘC-B} 0.2°C/W. This low thermal resistance is possible by utilizing a copper based MCPCB with pedestal design. The emitter thermal slug is in direct contact with the copper core. There are several vendors that offer similar solutions, some of them are: Rayben, Bergquist, SinkPad, Bridge-Semiconductor.

Components used

MCPCB: MHE-301 copper (Rayben)
ESD chips: BZX884-C18 (NXP, for 3 LED die)

| Pad layout | | | |
|------------|-----------|------------|-----------|
| Ch. | MCPCB Pad | String/die | Function |
| 1 | 4 | 1/ABE | Cathode - |
| | 3 | | Anode + |
| 2 | 5 | 2/CGI | Cathode - |
| | 2 | | Anode + |
| 3 | 6 | 3/DFH | Cathode - |
| | 1 | | Anode + |

LZ9 secondary TIR optics family

LLxx-3T06-H

Optical Specification

| Part number ¹ | Beam angle ² | Field angle ³ | Optical efficiency ⁴ | On-axis intensity ⁵ |
|--------------------------|-------------------------|--------------------------|---------------------------------|--------------------------------|
| | degrees | degrees | % | cd/lm |
| LLSP-3T06-H | 17 | 36 | 90 | 5.4 |
| LLNF-3T06-H | 26 | 49 | 90 | 2.2 |
| LLFL-3T06-H | 39 | 83 | 90 | 1.2 |

Notes:

1. Lenses can also be ordered without the holder. Replace –H with –O for this option.
2. Beam angle is defined as the full width at 50% of the max intensity (FWHM).
3. Field angle is defined as the full width at 10% of the max intensity.
4. Optical efficiency is defined as the ratio between the incoming flux and the outgoing flux.
5. On-axis intensity is defined as the ratio between the total input lumen and the intensity in the optical center of the lens.

Typical Relative Intensity over Angle

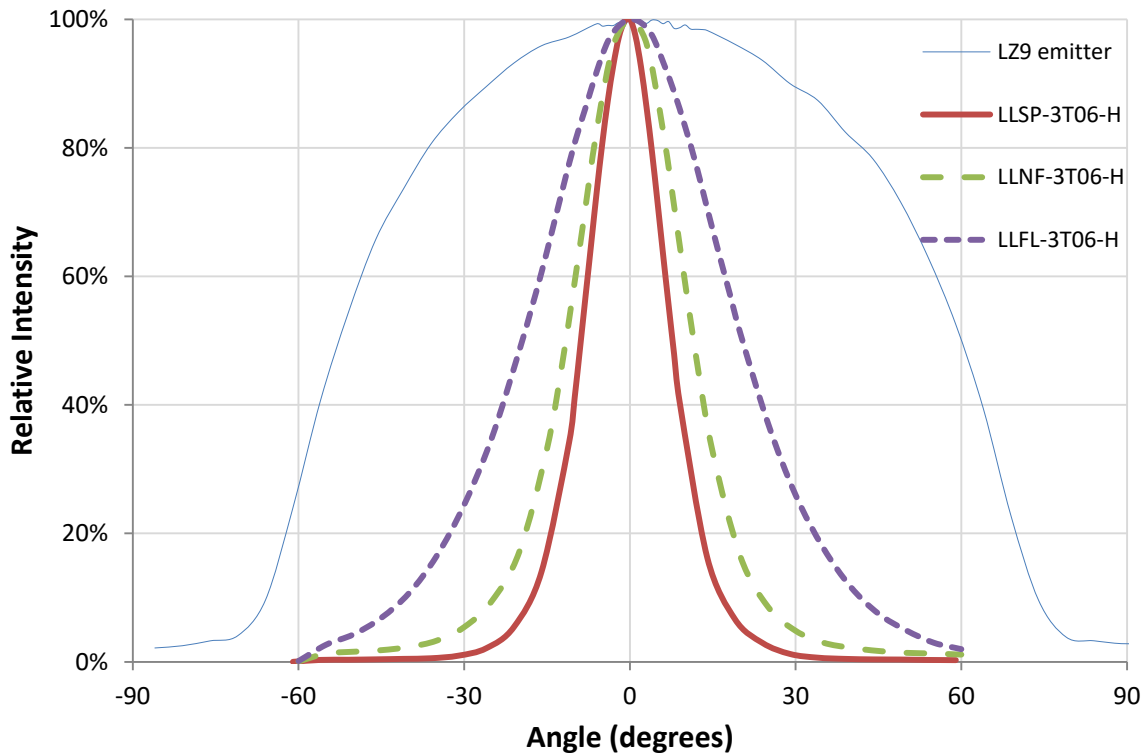

General Characteristics

| | Symbol | Value | Rating | Unit |
|----------------------------------|-----------|---------------|----------|------|
| Mechanical | | | | |
| Height from Seating Plane | | 19.2 | Typical | mm |
| Diameter | | 38.9 | Typical | mm |
| Material | | | | |
| Lens | | PMMA | | |
| Holder | | Polycarbonate | | |
| Optical | | | | |
| Transmission ¹ (>90%) | λ | 410-1100 | Min-Max. | nm |
| Environmental | | | | |
| Storage Temperature | T_{stg} | -40 ~ +110 | Min-Max. | °C |
| Operating Temperature | T_{sol} | -40 ~ +110 | Min-Max. | °C |

Notes:

1. It is not recommended to use a UV emitter with this lens due to lower transmission at wavelengths < 410nm.

Mechanical dimensions

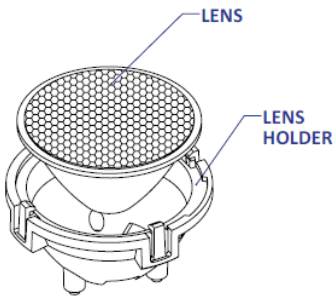

Lens with Holder

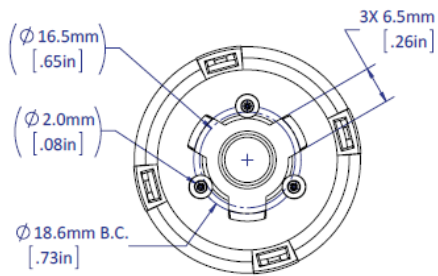
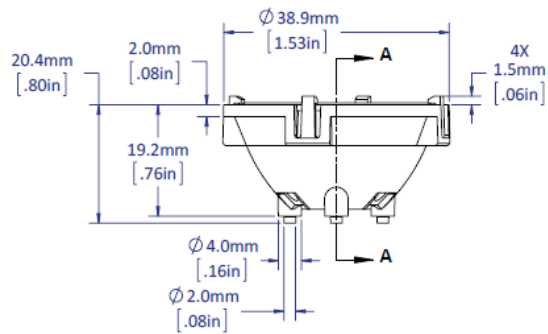

Lens

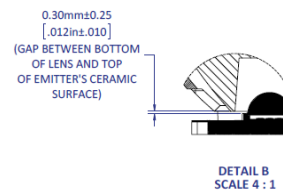
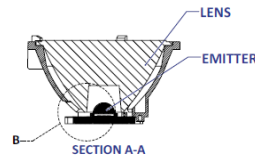
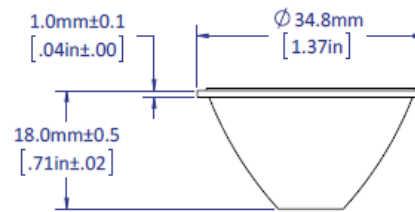

About LED Engin

LED Engin, an OSRAM business based in California's Silicon Valley, develops, manufactures, and sells advanced LED emitters, optics and light engines to create uncompromised lighting experiences for a wide range of entertainment, architectural, general lighting and specialty applications. LuxiGen™ multi-die emitter and secondary lens combinations reliably deliver industry-leading flux density, upwards of 5000 quality lumens to a target, in a wide spectrum of colors including whites, tunable whites, multi-color and UV LEDs in a unique patented compact ceramic package. Our LuxiTune™ series of tunable white lighting modules leverage our LuxiGen emitters and lenses to deliver quality, control, freedom and high density tunable white light solutions for a broad range of new recessed and downlighting applications. The small size, yet remarkably powerful beam output and superior in-source color mixing, allows for a previously unobtainable freedom of design wherever high-flux density, directional light is required. LED Engin is committed to providing products that conserve natural resources and reduce greenhouse emissions; and reserves the right to make changes to improve performance without notice.

For more information, please contact LEDE-Sales@osram.com or +1 408 922-7200.

Looking for pricing, stock, or lifecycle information?

Click below to explore more details on WIN SOURCE:

 [View LZ9-M0CW00-0055](#) on WIN SOURCE

 [LED Engin Inc.](#) Information

Optimize Your Supply Chain with WIN SOURCE Solutions

-  Global Sourcing Solution
-  Obsolete Management
-  Cost Control Management
-  Shortage Management
-  Alternative Solution
-  Excess Inventory Management