



**THE DATASHEET OF  
LZ4-00MD00**



High Luminous Efficacy  
RGBW LED Emitter

# LZ4-00MD00

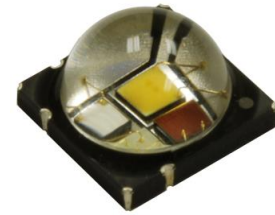

## Key Features

- High Luminous Efficacy 10W RGBW LED
- Individually addressable Red, Green, Blue and Daylight White die
- Electrically neutral thermal path
- Ultra-small foot print – 7.0mm x 7.0mm
- Surface mount ceramic package with integrated glass lens
- Very low Thermal Resistance (1.1°C/W)
- Very high Luminous Flux density
- JEDEC Level 1 for Moisture Sensitivity Level
- Autoclave compliant (JEDEC JESD22-A102-C)
- Lead (Pb) free and RoHS compliant
- Reflow solderable (up to 6 cycles)
- Emitter available on Standard MCPCB (optional)

## Typical Applications

- Architectural Lighting
- Retail Spot and Display Lighting
- Stage and Studio Lighting
- Hospitality Lighting
- Museum Lighting
- Video Walls and Full Color Displays

## Description

The LZ4-00MD00 RGBW LED emitter contains one red, green, blue and daylight white LED die which provides 10W power in an extremely small package. With a 7.0mm x 7.0mm ultra-small footprint, this package provides exceptional luminous flux density. LED Engin's RGBW LED offers ultimate design flexibility with individually addressable die. The LZ4-00MD00 is capable of producing a continuous spectrum of white light plus millions of colors. The patented design has unparalleled thermal and optical performance. The high quality materials used in the package are chosen to optimize light output and minimize stresses which results in monumental reliability and lumen maintenance. The robust product design thrives in outdoor applications with high ambient temperatures and high humidity.

## Part number options

### Base part number

Part number	Description
LZ4-00MD00-xxxx	LZ4 emitter
LZ4-20MD00-xxxx	LZ4 emitter on Standard Star 4 channel MCPCB

### Bin kit option codes

MD, Red-Green-Blue-White (5000K – 6500K)			
Kit number suffix	Min flux Bin	Color Bin Ranges	Description
0000	09R	R2 – R2	Red, full distribution flux; full distribution wavelength
	12G	G2 – G3	Green, full distribution flux; full distribution wavelength
	01B	B01 – B02	Blue, full distribution flux; full distribution wavelength
	01W	0bd, 0uy, 1bd, 1uy, 2vx, 2bd	White full distribution flux and CCT

## Daylight White Chromaticity Groups

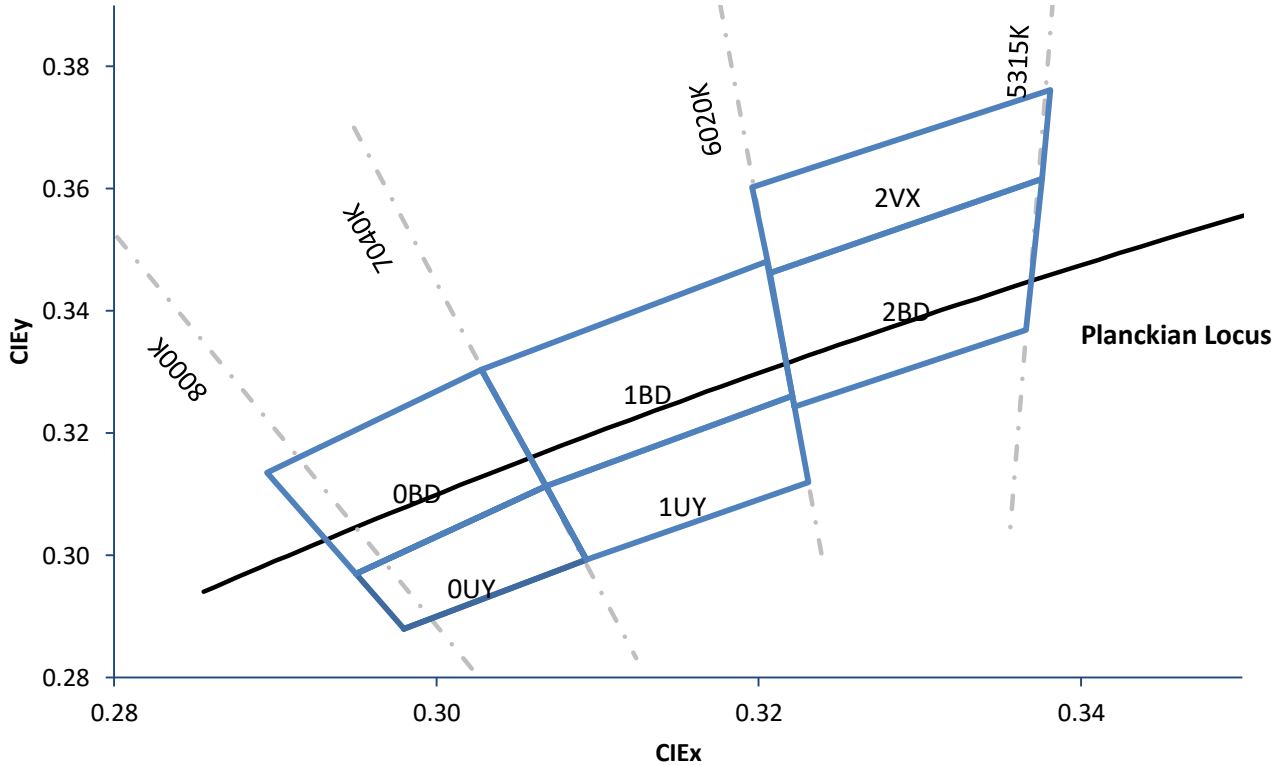

Standard Chromaticity Groups plotted on excerpt from the CIE 1931 (2°) x-y Chromaticity Diagram. Coordinates are listed below in Table 5.

## Cool White Bin Coordinates

Bin Code	CIE <sub>x</sub>	CIE <sub>y</sub>	Bin Code	CIE <sub>x</sub>	CIE <sub>y</sub>	Bin Code	CIE <sub>x</sub>	CIE <sub>y</sub>
OBD	0.295	0.297	1BD	0.3068	0.3113	2VX	0.3207	0.3462
	0.2895	0.3135		0.3028	0.3304		0.3196	0.3602
	0.3028	0.3304		0.3205	0.3481		0.3381	0.3762
	0.3068	0.3113		0.3221	0.3261		0.3376	0.3616
	0.295	0.297		0.3068	0.3113		0.3207	0.3462
OUY	0.298	0.288	1UY	0.3093	0.2993	2BD	0.3222	0.3243
	0.295	0.297		0.3068	0.3113		0.3207	0.3462
	0.3068	0.3113		0.3221	0.3261		0.3376	0.3616
	0.3093	0.2993		0.3231	0.312		0.3366	0.3369
	0.298	0.288		0.3093	0.2993		0.3222	0.3243

## Luminous Flux Bins

Table 1:

Bin Code	Minimum Luminous Flux ( $\Phi_v$ ) @ $I_f = 700\text{mA}$ <sup>[1,2]</sup> (lm)				Maximum Luminous Flux ( $\Phi_v$ ) @ $I_f = 700\text{mA}$ <sup>[1,2]</sup> (lm)			
	Red	Green	Blue	White	Red	Green	Blue	White
	09R	90				140		
12G		125				195		
01B			17				27	
02B			27				43	
01W				155				225

Notes for Table 1:

1. Luminous flux performance guaranteed within published operating conditions. LED Engin maintains a tolerance of  $\pm 10\%$  on flux measurements.
2. Future products will have even higher levels of radiant flux performance. Contact LED Engin Sales for updated information.

## Dominant Wavelength Bins

Table 2:

Bin Code	Minimum Dominant Wavelength ( $\lambda_D$ ) @ $I_f = 700\text{mA}$ <sup>[1]</sup> (nm)			Maximum Dominant Wavelength ( $\lambda_D$ ) @ $I_f = 700\text{mA}$ <sup>[1]</sup> (nm)		
	Red	Green	Blue	Red	Green	Blue
	R2	618			630	
G2		520			525	
G3		525			530	
B01			452			457
B02			457			462

Notes for Table 2:

1. LED Engin maintains a tolerance of  $\pm 1.0\text{nm}$  on dominant wavelength measurements.

## Forward Voltage Bin

Table 3:

Bin Code	Minimum Forward Voltage ( $V_f$ ) @ $I_f = 700\text{mA}$ <sup>[1]</sup> (V)				Maximum Forward Voltage ( $V_f$ ) @ $I_f = 700\text{mA}$ <sup>[1]</sup> (V)			
	Red	Green	Blue	White	Red	Green	Blue	White
	0	2.10	3.20	3.20	3.20	3.20	4.20	4.00

Notes for Table 3:

1. LED Engin maintains a tolerance of  $\pm 0.04\text{V}$  on forward voltage measurements.

## Absolute Maximum Ratings

Table 4:

Parameter	Symbol	Value	Unit
DC Forward Current $T_i = 150C$	$I_F$	1000	mA
DC Forward Current <sup>[1]</sup> $T_i = 130C$	$I_F$	1200	mA
Peak Pulsed Forward Current <sup>[2]</sup>	$I_{FP}$	1500	mA
Reverse Voltage	$V_R$	See Note 3	V
Storage Temperature	$T_{std}$	-40 ~ +150	°C
Junction Temperature	$T_J$	150	°C
Soldering Temperature <sup>[4]</sup>	$T_{sol}$	260	°C
Allowable Reflow Cycles		6	
Autoclave Conditions <sup>[5]</sup>		121°C at 2 ATM, 100% RH for 168 hours	
ESD Sensitivity <sup>[6]</sup>		> 8,000 V HBM Class 3B JESD22-A114-D	

Notes for Table 4:

- Maximum DC forward current is determined by the overall thermal resistance and ambient temperature. Follow the curves in Figure 12 for current derating. Max current for continuous operation is 1.0A
- Pulse forward current conditions: Pulse Width  $\leq 10$ msec and Duty Cycle  $\leq 10\%$ .
- LEDs are not designed to be reversing biased.
- Solder conditions per JEDEC 020D. See Reflow Soldering Profile Figure 4.
- Autoclave Conditions per JEDEC JESD22-A102-C.
- LED Engin recommends taking reasonable precautions towards possible ESD damages and handling the emitter in an electrostatic protected area (EPA). An EPA may be adequately protected by ESD controls as outlined in ANSI/ESD S6.1.

## Optical Characteristics @ $T_c = 25^\circ C$

Table 5:

Parameter	Symbol	Typical				Unit
		Red	Green	Blue <sup>[1]</sup>	White	
Luminous Flux (@ $I_F = 700$ mA)	$\Phi_V$	115	155	30	170	lm
Luminous Flux (@ $I_F = 1000$ mA)	$\Phi_V$	160	200	40	222	lm
Dominant Wavelength		623	523	460		
Correlated Color Temperature	CCT				6500	K
Color Rendering Index (CRI)	$R_a$				75	
Viewing Angle <sup>[2]</sup>	$2\theta_{\frac{1}{2}}$		95			
Total Included Angle <sup>[3]</sup>	$\theta_{0.9}$		115			Degrees

Notes for Table 5:

- When operating the Blue LED, observe IEC 60825-1 class 2 rating. Do not stare into the beam.
- Viewing Angle is the off axis angle from emitter centerline where the luminous intensity is  $\frac{1}{2}$  of the peak value.
- Total Included Angle is the total angle that includes 90% of the total luminous flux.

## Electrical Characteristics @ $T_c = 25^\circ C$

Table 6:

Parameter	Symbol	Typical				Unit
		Red	Green	Blue	White	
Forward Voltage (@ $I_F = 700$ mA)	$V_F$	2.2	3.35	3.2	3.2	V
Temperature Coefficient of Forward Voltage	$\Delta V_F / \Delta T_J$	-1.9	-2.9	-3.0	-3.0	mV/°C
Thermal Resistance (Junction to Case)	$R\theta_{J-C}$		1.1			°C/W

## IPC/JEDEC Moisture Sensitivity Level

Table 7 - IPC/JEDEC J-STD-20D.1 MSL Classification:

Level	Floor Life		Soak Requirements			
	Time	Conditions	Standard	Accelerated	Time (hrs)	Conditions
1	Unlimited	≤ 30°C/ 85% RH	168 +5/-0	85°C/ 85% RH	n/a	n/a

Notes for Table 7:

- The standard soak time includes a default value of 24 hours for semiconductor manufacturer's exposure time (MET) between bake and bag and includes the maximum time allowed out of the bag at the distributor's facility.

## Average Lumen Maintenance Projections

Lumen maintenance generally describes the ability of a lamp to retain its output over time. The useful lifetime for solid state lighting devices (Power LEDs) is also defined as Lumen Maintenance, with the percentage of the original light output remaining at a defined time period.

Based on long-term WHTOL testing, LED Engin projects that the LZ Series will deliver, on average, 70% Lumen Maintenance at 65,000 hours of operation at a forward current of 700 mA. This projection is based on constant current operation with junction temperature maintained at or below 125°C.

## Mechanical Dimensions (mm)

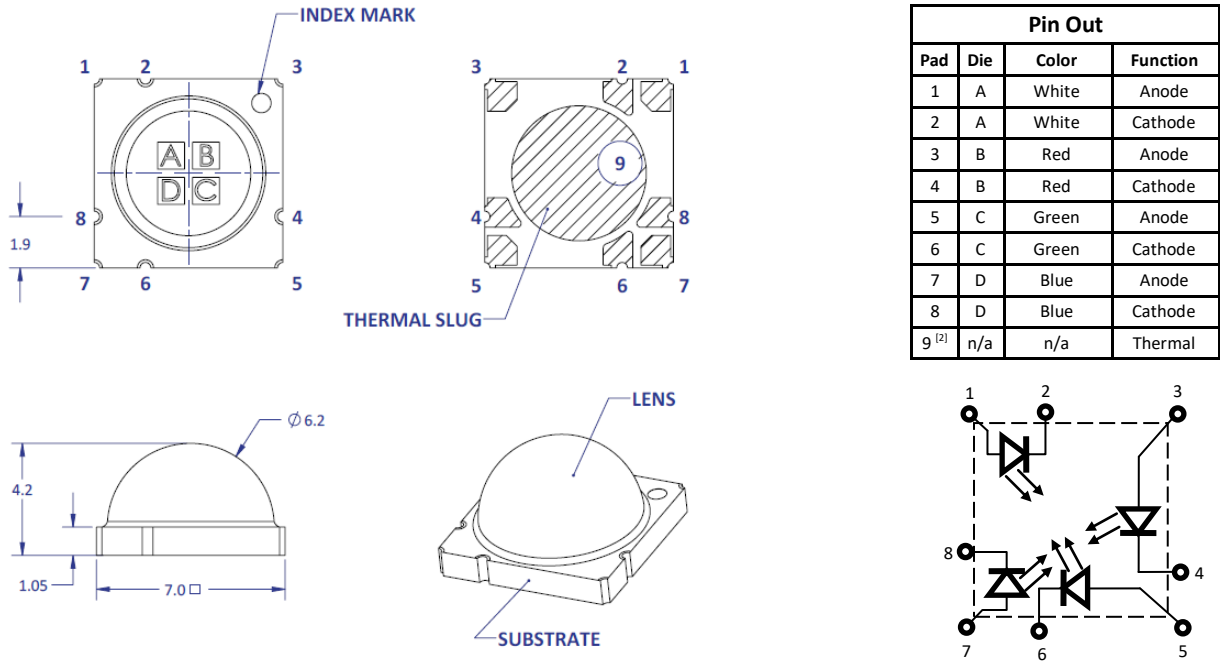

Figure 1: Package Outline Drawing.

Notes for Figure 1:

1. Unless otherwise noted, the tolerance =  $\pm 0.20$  mm.
2. Thermal contact, Pad 9, is electrically neutral.

## Recommended Solder Pad Layout (mm)

### Non-pedestal MCPCB Design

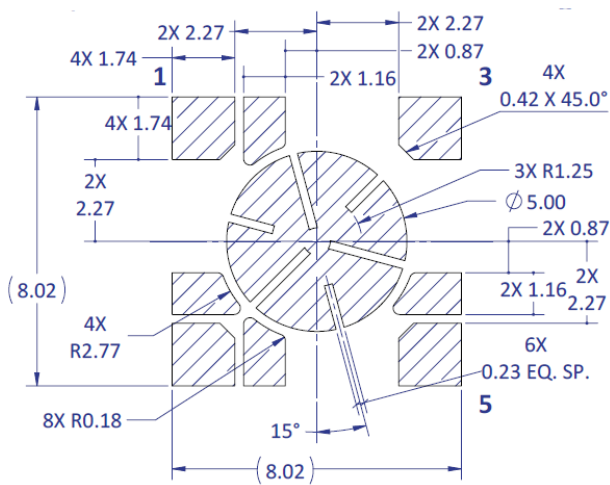

### Pedestal MCPCB Design

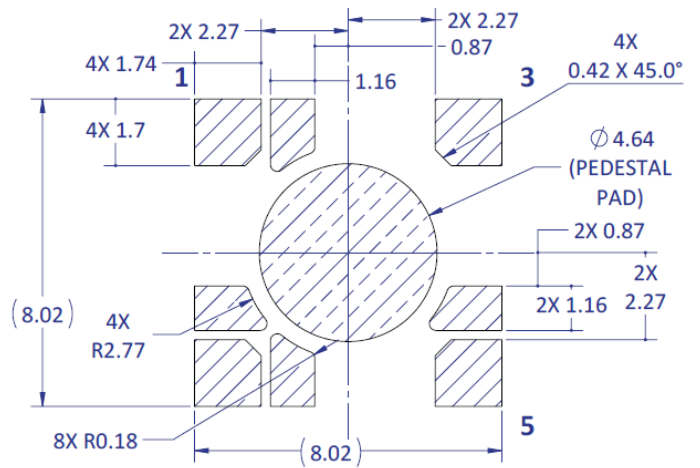

Figure 2a: Recommended solder pad layout for anode, cathode, and thermal pad for non-pedestal and pedestal design

Note for Figure 2a:

1. Unless otherwise noted, the tolerance =  $\pm 0.20$  mm.
2. Pedestal MCPCB allows the emitter thermal slug to be soldered directly to the metal core of the MCPCB. Such MCPCB eliminate the high thermal resistance dielectric layer that standard MCPCB technologies use in between the emitter thermal slug and the metal core of the MCPCB, thus lowering the overall system thermal resistance.
3. LED Engin recommends x-ray sample monitoring for solder voids underneath the emitter thermal slug. The total area covered by solder voids should be less than 20% of the total emitter thermal slug area. Excessive solder voids will increase the emitter to MCPCB thermal resistance and may lead to higher failure rates due to thermal over stress.

## Recommended Solder Mask Layout (mm)

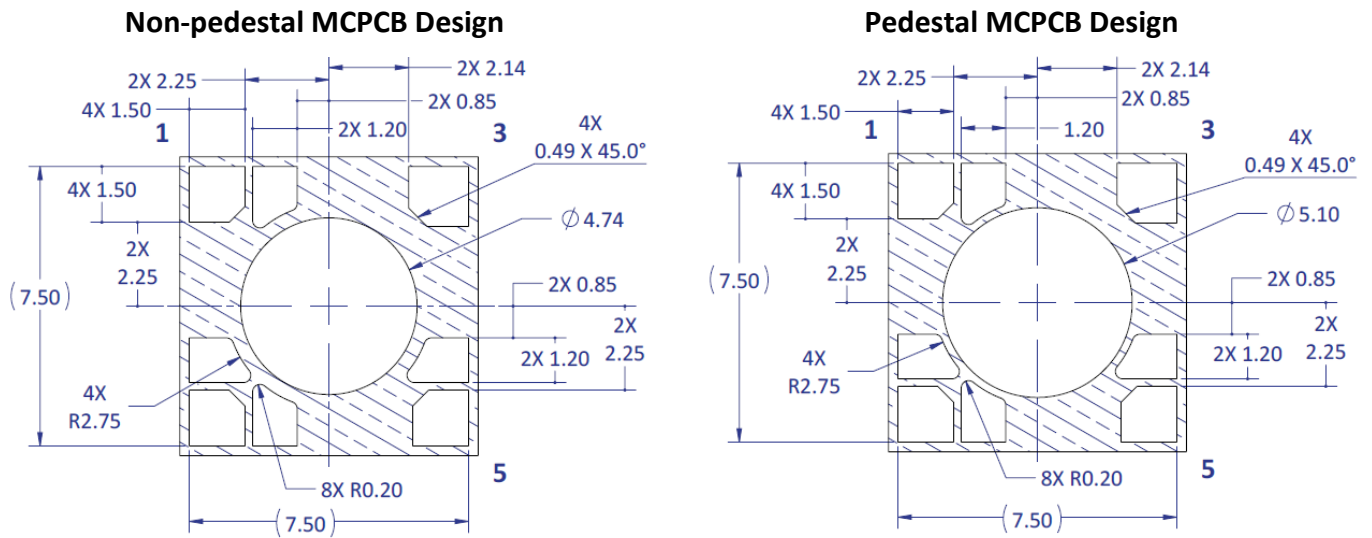

Figure 2b: Recommended solder mask opening for anode, cathode, and thermal pad for non-pedestal and pedestal design

Note for Figure 2b:

1. Unless otherwise noted, the tolerance =  $\pm 0.20$  mm.

## Recommended 8 mil Stencil Apertures Layout (mm)

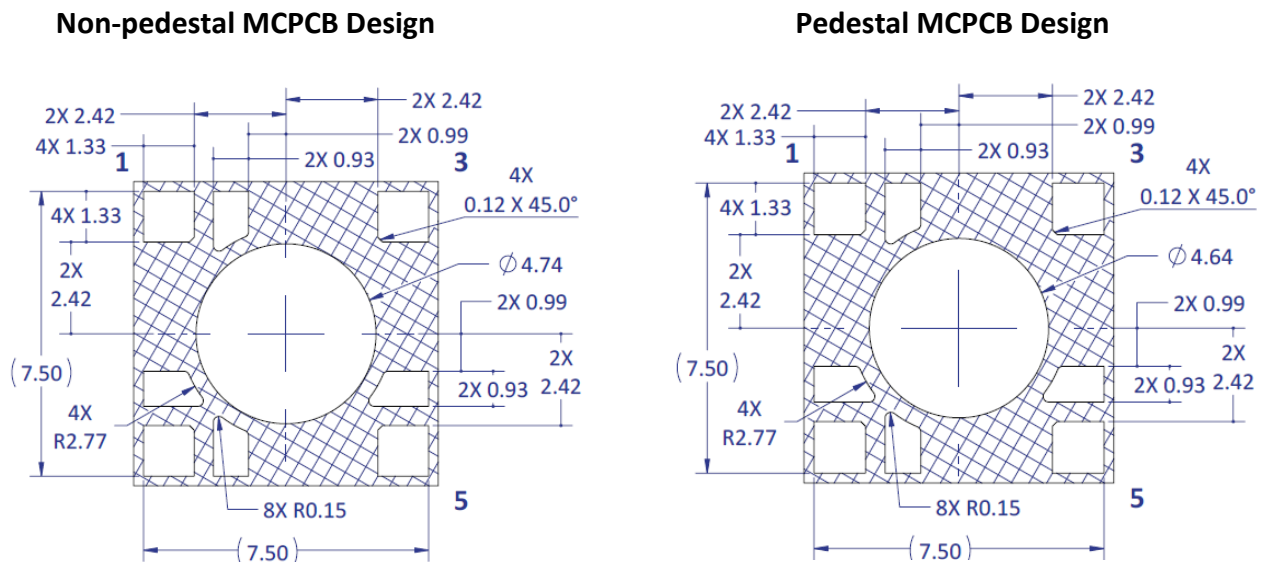

Figure 2c: Recommended 8mil stencil apertures for anode, cathode, and thermal pad for non-pedestal and pedestal design

Note for Figure 2c:

1. Unless otherwise noted, the tolerance =  $\pm 0.20$  mm.

## Reflow Soldering Profile

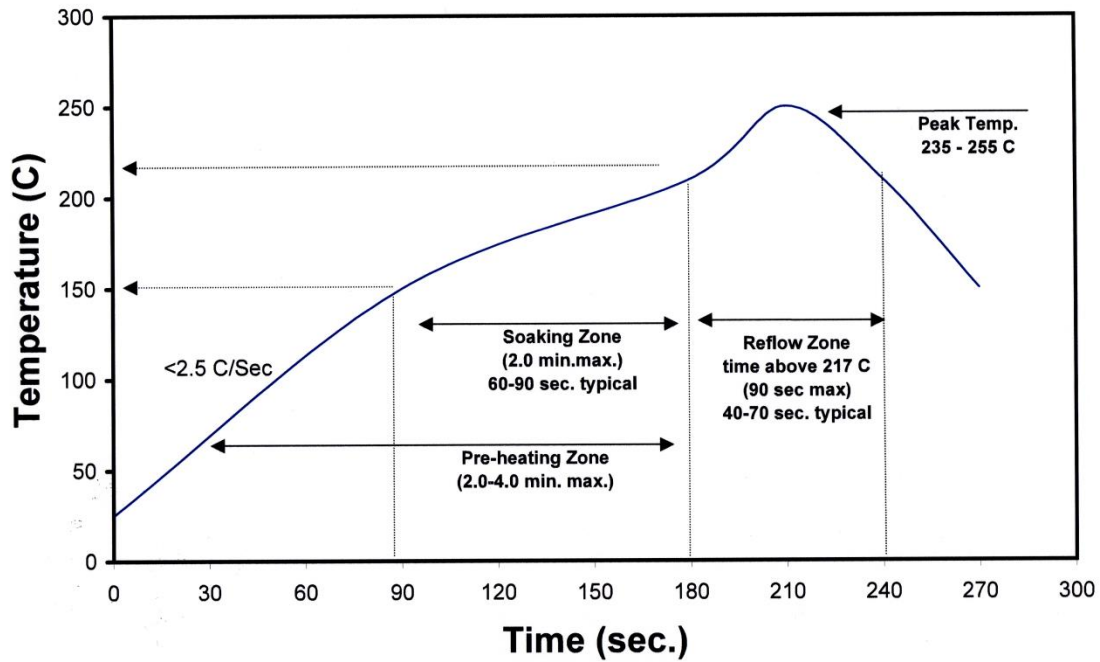

Figure 3: Reflow soldering profile for lead free soldering.

## Typical Radiation Pattern

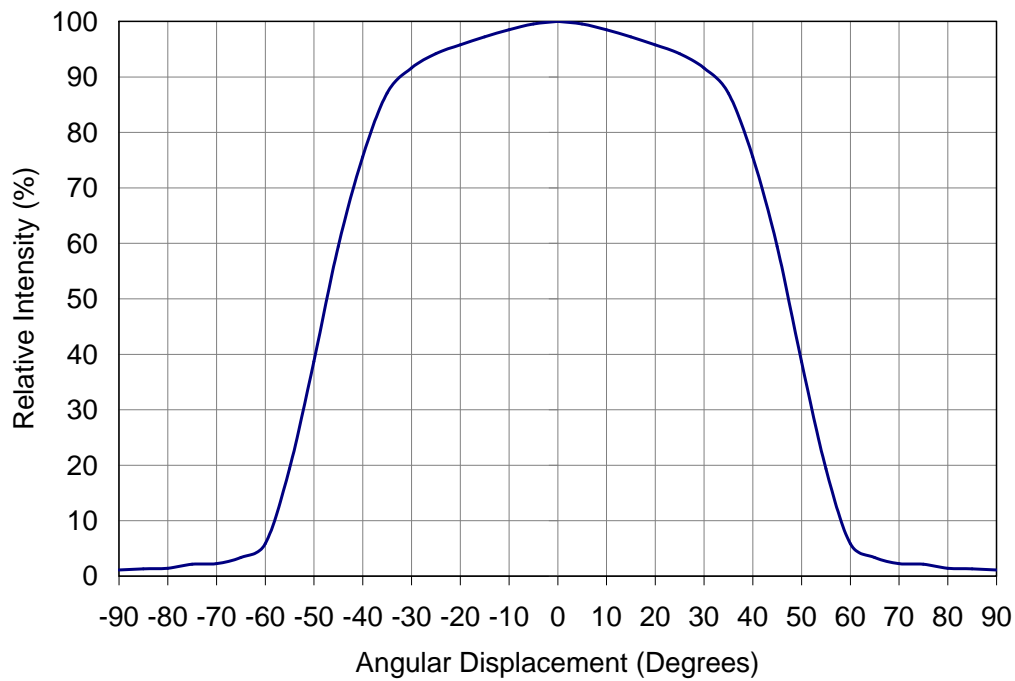

Figure 4: Typical representative spatial radiation pattern.

### Typical Relative Spectral Power Distribution

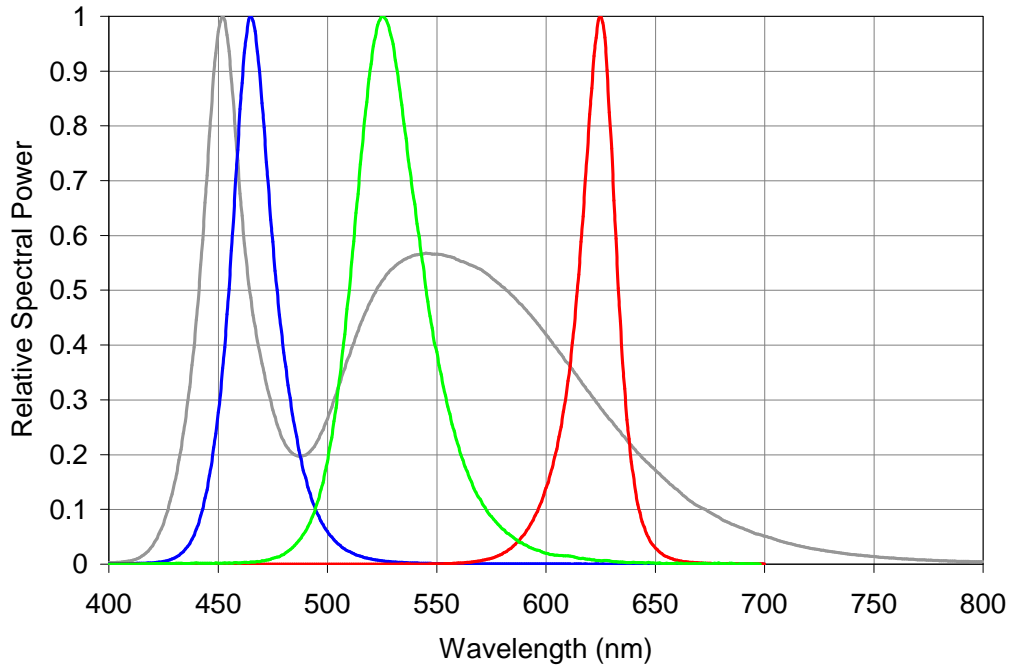

Figure 5: Typical relative spectral power vs. wavelength @ T<sub>c</sub> = 25°C.

### Typical Dominant Wavelength Shift

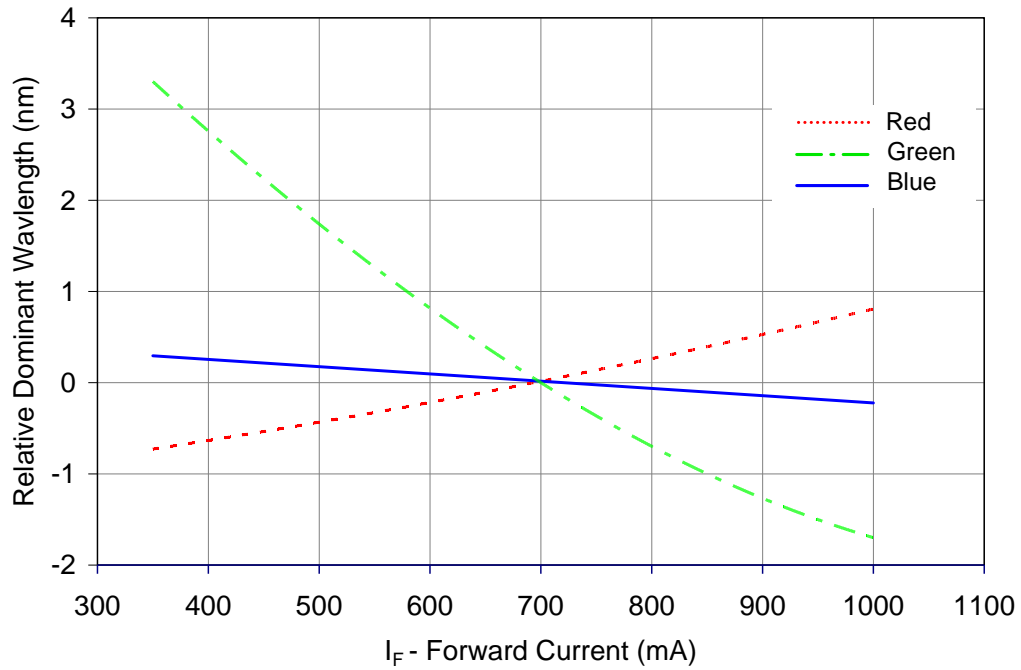

Figure 6: Typical dominant wavelength shift vs. forward current @ T<sub>c</sub> = 25°C.

## Dominant Wavelength Shift over Temperature

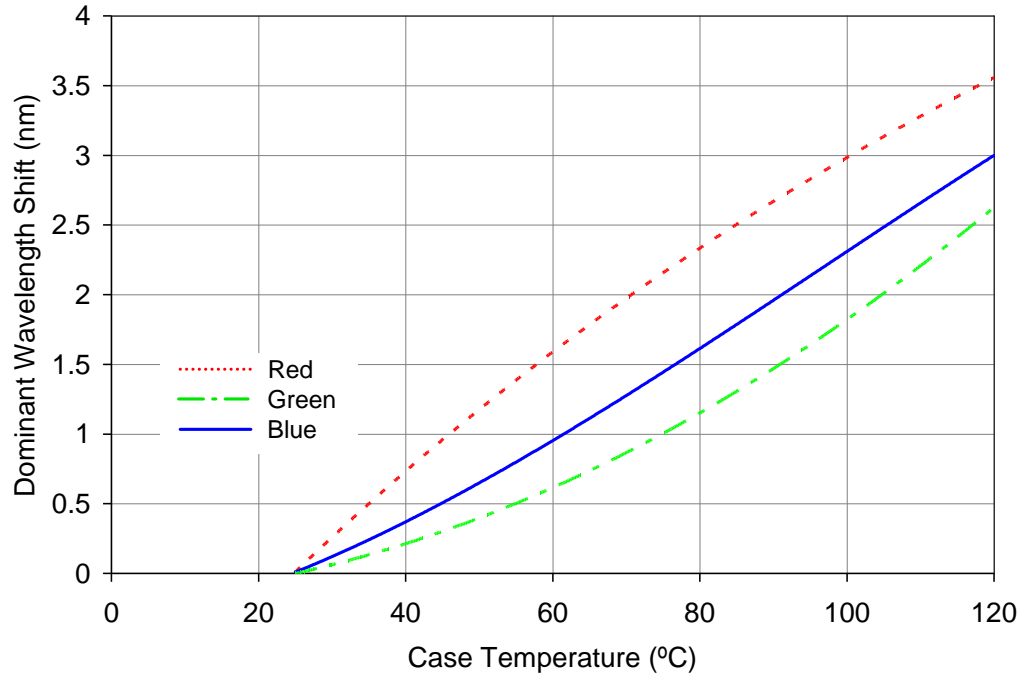

Figure 7: Typical dominant wavelength shift vs. case temperature.

## Typical Relative Light Output

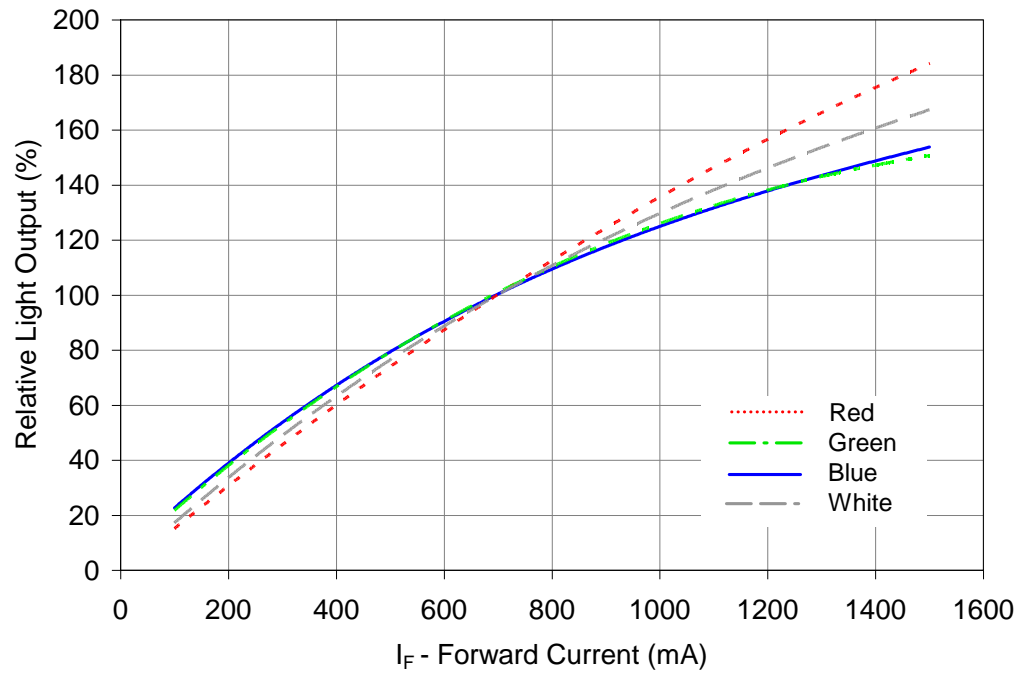

Figure 8: Typical relative light output vs. forward current @ T<sub>c</sub> = 25°C.

### Typical Relative Light Output over Temperature

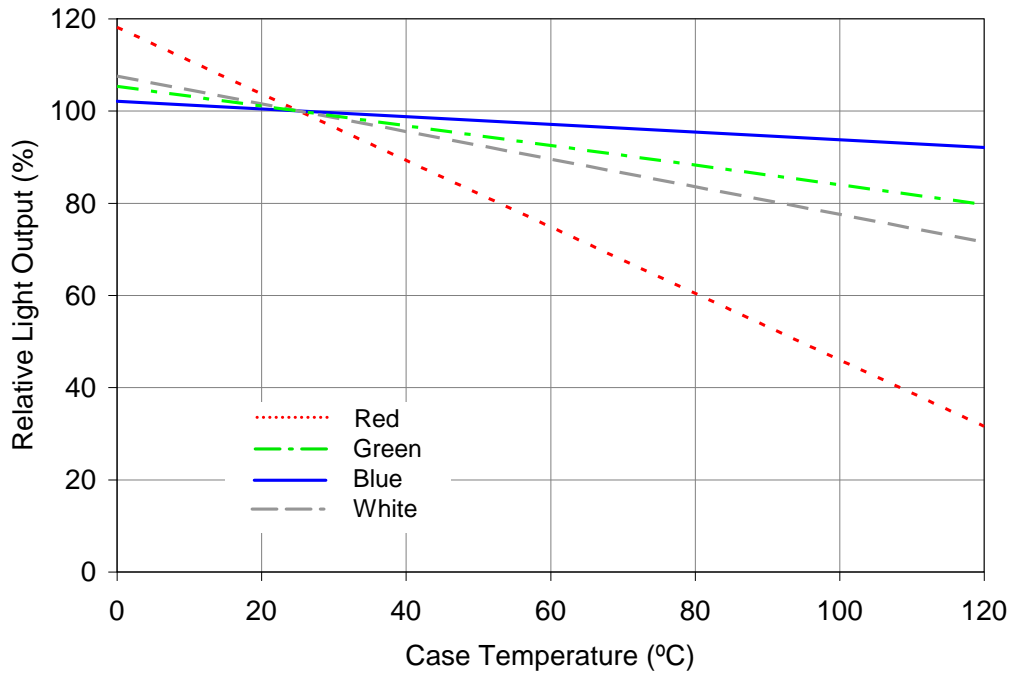

Figure 9: Typical relative light output vs. case temperature.

### Typical Forward Current Characteristics

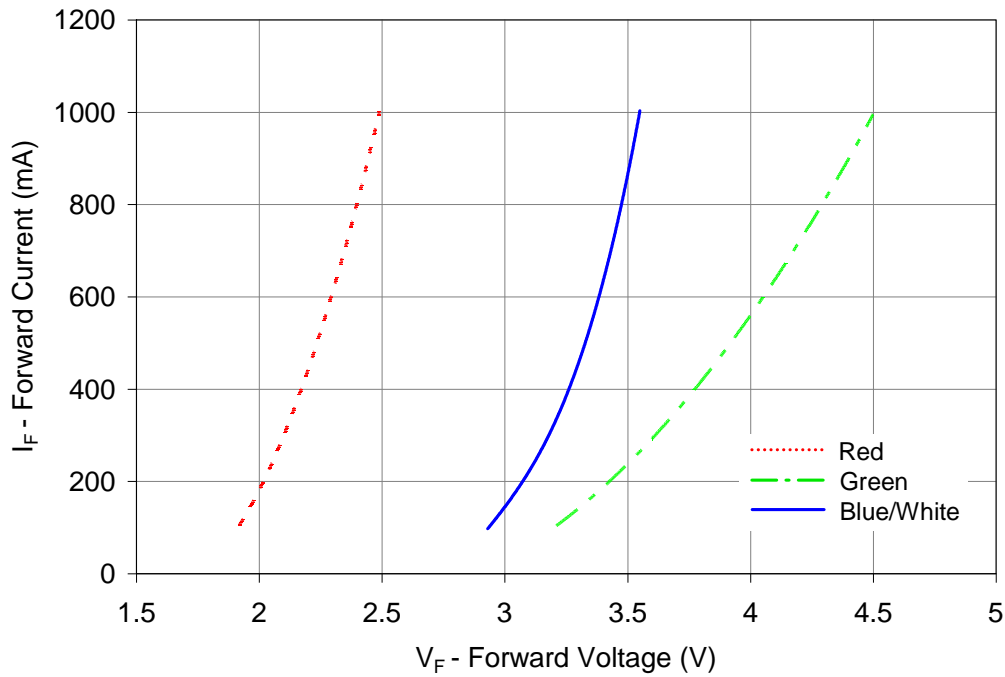

Figure 10: Typical forward current vs. forward voltage @ T<sub>c</sub> = 25°C.

## Current De-rating

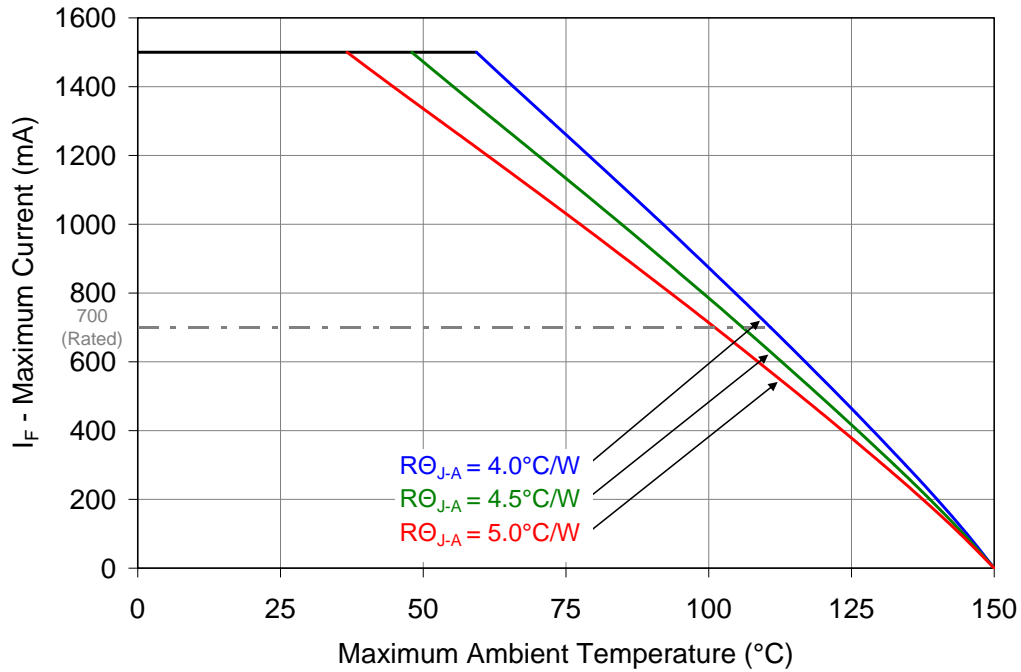

Figure 11: Maximum forward current vs. ambient temperature based on  $T_{J(\text{MAX})} = 150^{\circ}\text{C}$ .

### Notes for Figure 11:

1. Maximum current assumes that all four LED dice are operating concurrently at the same current.
2.  $R\theta_{J-C}$  [Junction to Case Thermal Resistance] for the LZ4-00MD00 is typically  $1.1^{\circ}\text{C/W}$ .
3.  $R\theta_{J-A}$  [Junction to Ambient Thermal Resistance] =  $R\theta_{J-C} + R\theta_{C-A}$  [Case to Ambient Thermal Resistance].

## Emitter Tape and Reel Specifications (mm)

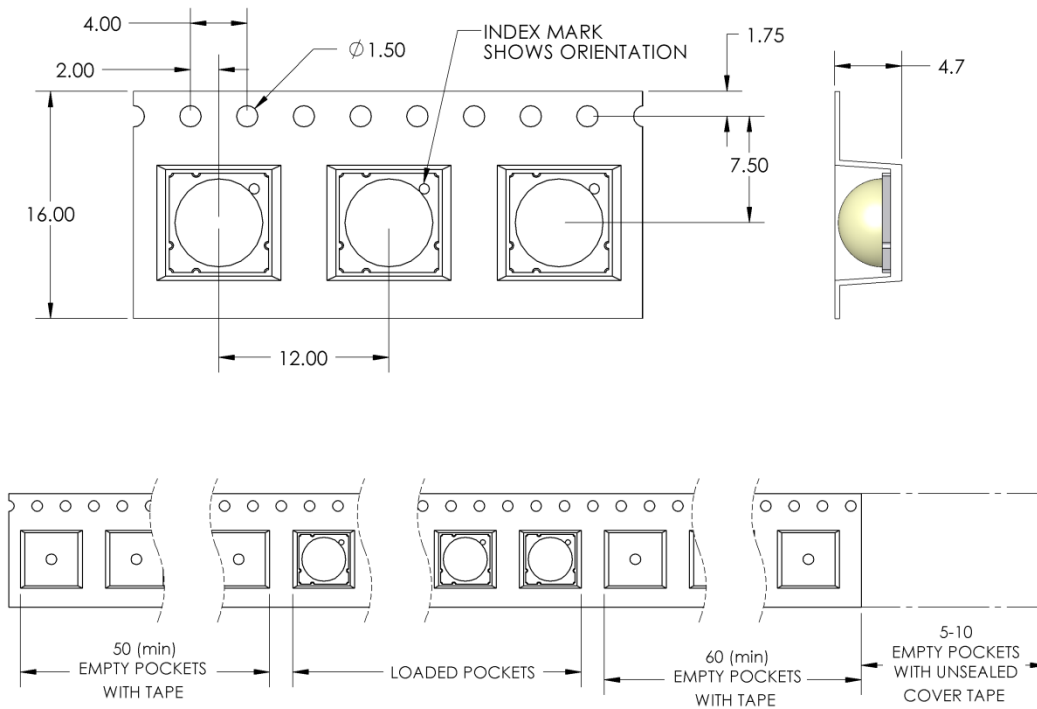

Figure 12: Emitter carrier tape specifications (mm).

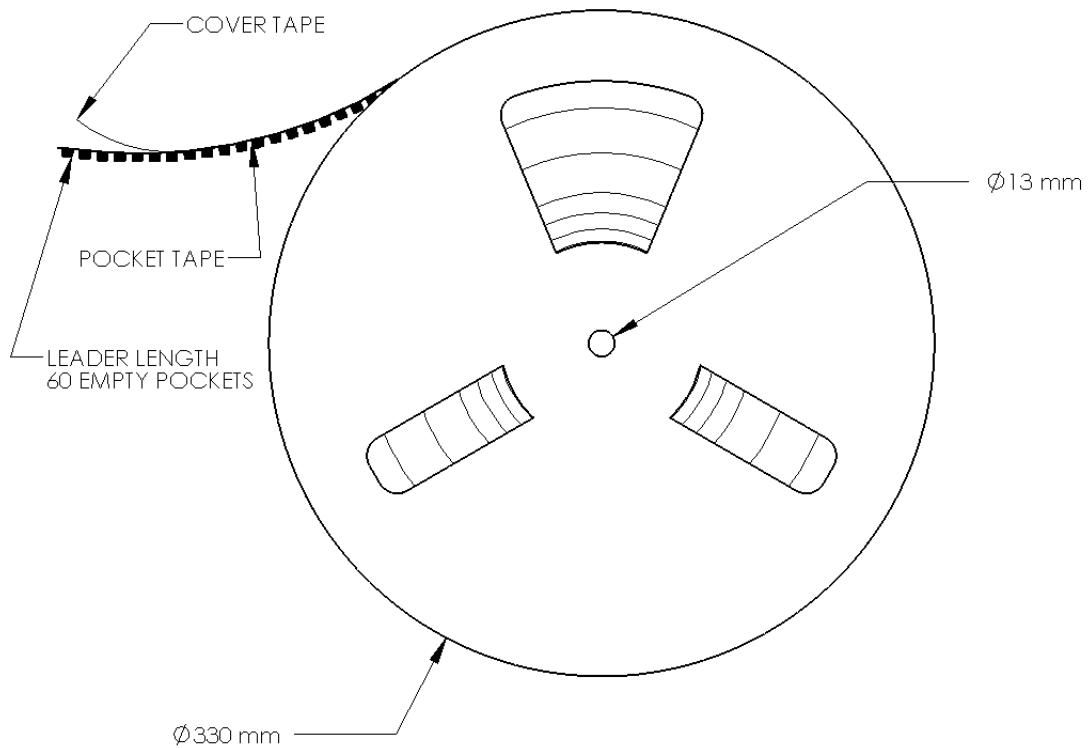

Figure 13: Emitter reel specifications (mm).

# LZ4 MCPCB Family

Part number	Type of MCPCB	Diameter (mm)	Emitter + MCPCB Thermal Resistance (°C/W)	Typical V <sub>f</sub> (V)	Typical I <sub>f</sub> (mA)
LZ4-2xxxxxx	4-channel	19.9	1.1 + 1.1 = 2.2	2.2 – 3.4	700

## Mechanical Mounting of MCPCB

- MCPCB bending should be avoided as it will cause mechanical stress on the emitter, which could lead to substrate cracking and subsequently LED dies cracking.
- To avoid MCPCB bending:
  - Special attention needs to be paid to the flatness of the heat sink surface and the torque on the screws.
  - Care must be taken when securing the board to the heat sink. This can be done by tightening three M3 screws (or #4-40) in steps and not all the way through at once. Using fewer than three screws will increase the likelihood of board bending.
  - It is recommended to always use plastics washers in combinations with the three screws.
  - If non-taped holes are used with self-tapping screws, it is advised to back out the screws slightly after tightening (with controlled torque) and then re-tighten the screws again.

## Thermal interface material

- To properly transfer heat from LED emitter to heat sink, a thermally conductive material is required when mounting the MCPCB on to the heat sink.
- There are several varieties of such material: thermal paste, thermal pads, phase change materials and thermal epoxies. An example of such material is Electrolube EHTC.
- It is critical to verify the material's thermal resistance to be sufficient for the selected emitter and its operating conditions.

## Wire soldering

- To ease soldering wire to MCPCB process, it is advised to preheat the MCPCB on a hot plate of 125-150°C. Subsequently, apply the solder and additional heat from the solder iron will initiate a good solder reflow. It is recommended to use a solder iron of more than 60W.
- It is advised to use lead-free, no-clean solder. For example: SN-96.5 AG-3.0 CU 0.5 #58/275 from Kester (pn: 24-7068-7601)

# LZ4-2xxxxx

## 4 channel, Standard Star MCPCB (4x1) Dimensions (mm)

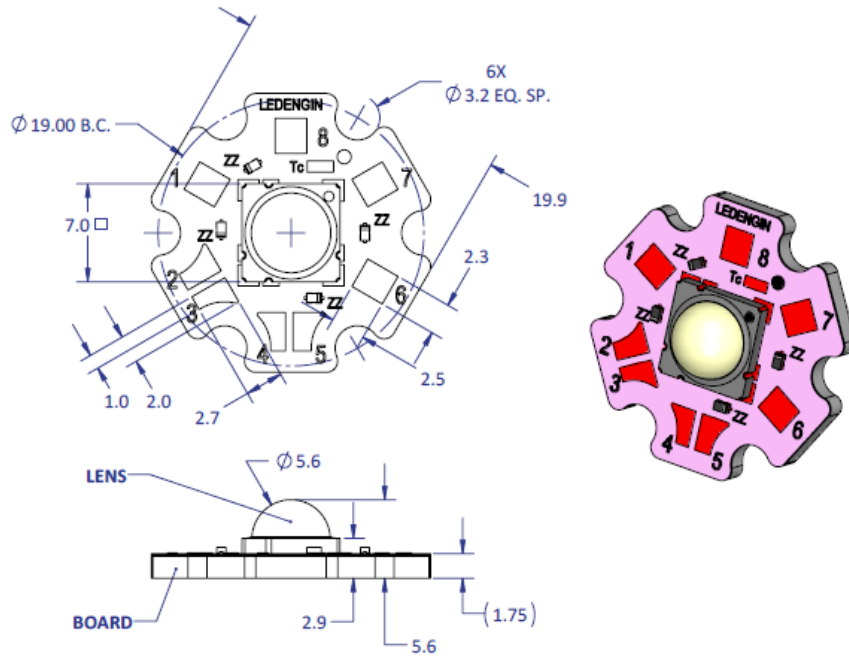

**Notes:**

- Unless otherwise noted, the tolerance =  $\pm 0.2$  mm.
- Slots in MCPCB are for M3 or #4-40 mounting screws.
- LED Engin recommends plastic washers to electrically insulate screws from solder pads and electrical traces.
- LED Engin recommends using thermal interface material when attaching the MCPCB to a heatsink.
- The thermal resistance of the MCPCB is:  $R_{\theta C-B}$  1.1°C/W

## Components used

MCPCB: HT04503 (Bergquist)  
ESD chips: BZT52C5-C10 (NPX, for 1 LED die)

Pad layout			
Ch.	MCPCB Pad	String/die	Function
1	1	1/A	Anode +
	8		Cathode -
2	7	2/B	Anode +
	6		Cathode -
3	5	3/C	Anode +
	4		Cathode -
4	3	4/D	Anode +
	2		Cathode -

## About LED Engin

LED Engin, an OSRAM business based in California's Silicon Valley, develops, manufactures, and sells advanced LED emitters, optics and light engines to create uncompromised lighting experiences for a wide range of entertainment, architectural, general lighting and specialty applications. LuxiGen™ multi-die emitter and secondary lens combinations reliably deliver industry-leading flux density, upwards of 5000 quality lumens to a target, in a wide spectrum of colors including whites, tunable whites, multi-color and UV LEDs in a unique patented compact ceramic package. Our LuxiTune™ series of tunable white lighting modules leverage our LuxiGen emitters and lenses to deliver quality, control, freedom and high density tunable white light solutions for a broad range of new recessed and downlighting applications. The small size, yet remarkably powerful beam output and superior in-source color mixing, allows for a previously unobtainable freedom of design wherever high-flux density, directional light is required. LED Engin is committed to providing products that conserve natural resources and reduce greenhouse emissions; and reserves the right to make changes to improve performance without notice.

For more information, please contact [LEDE-Sales@osram.com](mailto:LEDE-Sales@osram.com) or +1 408 922-7200.

## Looking for pricing, stock, or lifecycle information?

Click below to explore more details on WIN SOURCE:

 [View LZ4-00MD00 on WIN SOURCE](#)

 [LED Engin Inc. Information](#)

## Optimize Your Supply Chain with WIN SOURCE Solutions

-  Global Sourcing Solution
-  Obsolete Management
-  Cost Control Management
-  Shortage Management
-  Alternative Solution
-  Excess Inventory Management