



**THE DATASHEET OF
LZ1-00UA00-00U8**



High Efficacy
VIOLET LED Emitter

LZ1-00UA00

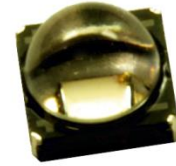

Key Features

- High Efficacy 5W VIOLET LED
- Ultra-small foot print – 4.4mm x 4.4mm
- Surface mount ceramic package with integrated glass lens
- Very low Thermal Resistance (4.2°C/W)
- Electrically neutral thermal path
- Very high Radiant Flux density
- Autoclave (121°C, 2 ATM, 100% RH, 168 Hours)
- JEDEC Level 1 for Moisture Sensitivity Level
- Lead (Pb) free and RoHS compliant
- Reflow solderable (up to 6 cycles)
- Emitter available on Standard or Miniature MCPCB (optional)

Typical Applications

- Dental Curing and Teeth Whitening
- Ink and adhesive curing
- Sterilization and Medical
- DNA Gel

Description

The LZ1-00UA00 VIOLET LED emitter provides superior radiometric power in the wavelength range specifically required for sterilization, dental curing lights, and numerous medical applications. With a 4.4mm x 4.4mm ultra-small footprint, this package provides exceptional optical power density. The radiometric power performance and optimal peak wavelength of this LED are matched to the response curves of dental resins, inks and adhesives, resulting in a significantly reduced curing time. The patented design has unparalleled thermal and optical performance. The high quality materials used in the package are chosen to optimize light output, have excellent VIOLET resistance, and minimize stresses which results in monumental reliability and radiant flux maintenance.

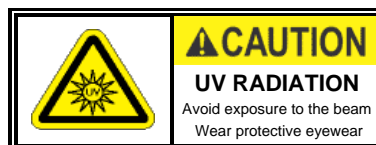

Part number options

Base part number

Part number	Description
LZ1-00UA00-xxxx	LZ1 emitter
LZ1-10UA00-xxxx	LZ1 emitter on Standard Star MCPCB
LZ1-30UA00-xxxx	LZ1 emitter on Miniature round MCPCB

Bin kit option codes

Single wavelength bin (5nm range)

Kit number suffix	Min flux Bin	Color Bin Range	Description
00U4	K	U4	K minimum flux; wavelength U4 bin only
00U5	L	U5	L minimum flux; wavelength U5 bin only
00U6	L	U6	L minimum flux; wavelength U6 bin only
00U7	L	U7	L minimum flux; wavelength U7 bin only
00U8	L	U8	L minimum flux; wavelength U8 bin only

Radiant Flux Bins

Table 1:

Bin Code	Minimum Radiant Flux (Φ) @ $I_F = 700\text{mA}$ ^[1,2] (mW)	Maximum Radiant Flux (Φ) @ $I_F = 700\text{mA}$ ^[1,2] (mW)
K	640	800
L	800	1000
M	1000	1250

Notes for Table 1:

1. Radiant flux performance guaranteed within published operating conditions. LED Engin maintains a tolerance of $\pm 10\%$ on flux measurements.
2. Future products will have even higher levels of radiant flux performance. Contact LED Engin Sales for updated information.

Peak Wavelength Bins

Table 2:

Bin Code	Minimum Peak Wavelength (λ_p) @ $I_F = 700\text{mA}$ ^[1] (nm)	Maximum Peak Wavelength (λ_p) @ $I_F = 700\text{mA}$ ^[1] (nm)
U4	385	390
U5	390	395
U6	395	400
U7	400	405
U8	405	410

Notes for Table 2:

1. LED Engin maintains a tolerance of $\pm 2.0\text{nm}$ on peak wavelength measurements.

Forward Voltage Bins

Table 3:

Bin Code	Minimum Forward Voltage (V_F) @ $I_F = 700\text{mA}$ ^[1] (V)	Maximum Forward Voltage (V_F) @ $I_F = 700\text{mA}$ ^[1] (V)
0	3.20	4.40

Notes for Table 3:

1. LED Engin maintains a tolerance of $\pm 0.04\text{V}$ for forward voltage measurements.

Absolute Maximum Ratings

Table 4:

Parameter	Symbol	Value	Unit
DC Forward Current ^[1]	I_F	1000	mA
Peak Pulsed Forward Current ^[2]	I_{FP}	1000	mA
Reverse Voltage	V_R	See Note 3	V
Storage Temperature	T_{stg}	-40 ~ +150	°C
Junction Temperature	T_J	125	°C
Soldering Temperature	T_{sol}	260	°C
Allowable Reflow Cycles		6	
Autoclave Conditions		121°C at 2 ATM, 100% RH for 168 hours	
ESD Sensitivity ^[4]		> 2,000 V HBM Class 2 JESD22-A114-D	

Notes for Table 4:

- Maximum DC forward current is determined by the overall thermal resistance and ambient temperature. Follow the curves in Figure 10 for current derating.
- Pulse forward current conditions: Pulse Width \leq 10msec and Duty Cycle \leq 10%.
- LEDs are not designed to be reverse biased.
- LED Engin recommends taking reasonable precautions towards possible ESD damages and handling the LZ1-00UA00 in an electrostatic protected area (EPA). An EPA may be adequately protected by ESD controls as outlined in ANSI/ESD S6.1.

Optical Characteristics @ $T_C = 25^\circ\text{C}$

Table 5:

Parameter	Symbol	Typical			Unit
		385-390nm	390-400nm	400-410nm	
Radiant Flux (@ $I_F = 700\text{mA}$)	Φ	760	900	1000	mW
Radiant Flux (@ $I_F = 1000\text{mA}$)	Φ	1070	1260	1400	mW
Peak Wavelength ^[1]	λ_p	385	395	405	nm
Viewing Angle ^[2]	$2\theta_{1/2}$		74		Degrees
Total Included Angle ^[3]	$\theta_{0.9V}$		110		Degrees

Notes for Table 5:

- When operating the VIOLET LED, observe IEC 60825-1 class 3B rating. Avoid exposure to the beam.
- Viewing Angle is the off axis angle from emitter centerline where the radiometric power is $\frac{1}{2}$ of the peak value.
- Total Included Angle is the total angle that includes 90% of the total radiant flux.

Electrical Characteristics @ $T_C = 25^\circ\text{C}$

Table 6:

Parameter	Symbol	Typical	Unit
Forward Voltage (@ $I_F = 700\text{mA}$)	V_F	3.9	V
Forward Voltage (@ $I_F = 1000\text{mA}$)	V_F	4.1	V
Temperature Coefficient of Forward Voltage	$\Delta V_F / \Delta T_J$	-3.7	mV/°C
Thermal Resistance (Junction to Case)	$R\theta_{J-C}$	4.2	°C/W

IPC/JEDEC Moisture Sensitivity Level

Table 7 - IPC/JEDEC J-STD-20D.1 MSL Classification:

Level	Floor Life		Soak Requirements			
	Time	Conditions	Standard	Accelerated	Time (hrs)	Conditions
1	Unlimited	≤ 30°C/ 85% RH	168 +5/-0	85°C/ 85% RH	n/a	n/a

Notes for Table 7:

- The standard soak time includes a default value of 24 hours for semiconductor manufacturer's exposure time (MET) between bake and bag and the floor life of maximum time allowed out of the bag at the end user of distributor's facility.

Average Radiant Flux Maintenance Projections

Lumen maintenance generally describes the ability of an emitter to retain its output over time. The useful lifetime for power LEDs is also defined as Radiant Flux Maintenance, with the percentage of the original light output remaining at a defined time period.

Based on long-term WHTOL testing, LED Engin projects that the LZ Series will deliver, on average, 70% Radiant Flux Maintenance (RP70%) at 20,000 hours of operation at a forward current of 700 mA per die. This projection is based on constant current operation with junction temperature maintained at or below 80°C.

Mechanical Dimensions (mm)

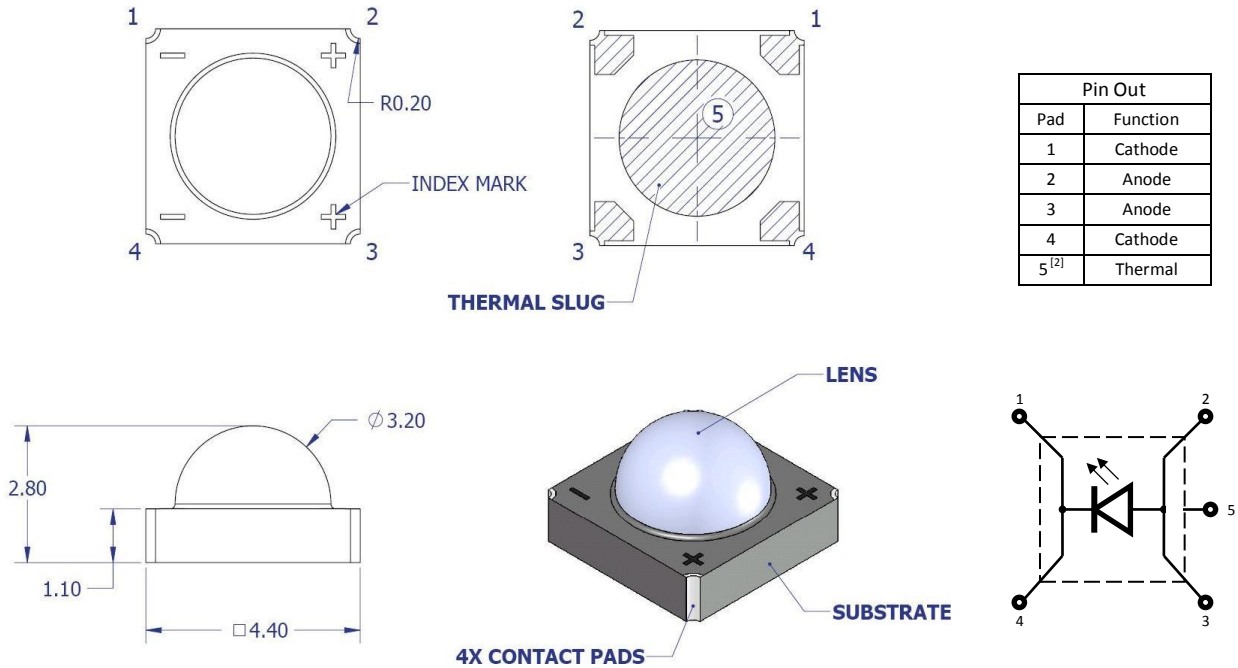

Figure 1: Package outline drawing.

Notes for Figure 1:

1. Unless otherwise noted, the tolerance = ± 0.20 mm.
2. Thermal contact, Pad 5, is electrically neutral.

Recommended Solder Pad Layout (mm)

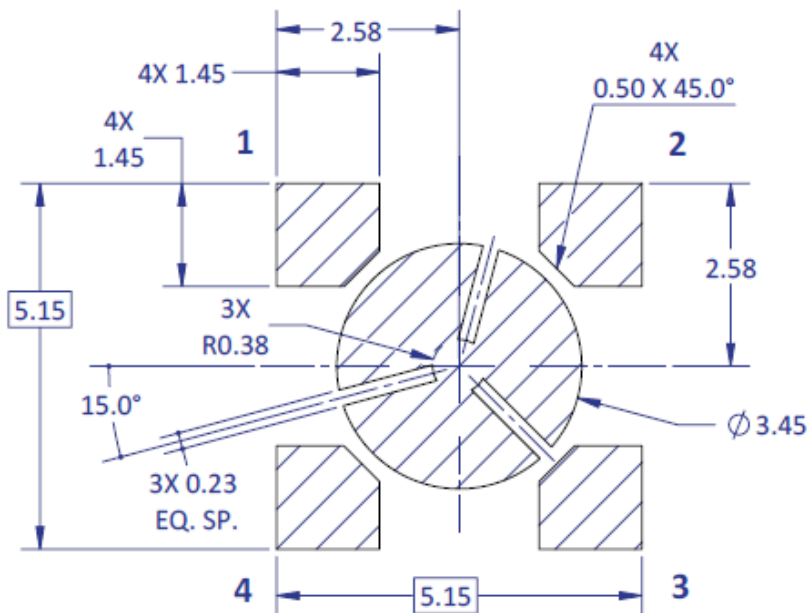

Figure 2a: Recommended solder pad layout for anode, cathode, and thermal pad

Note for Figure 2a:

1. Unless otherwise noted, the tolerance = ± 0.20 mm.

Recommended Solder Mask Layout (mm)

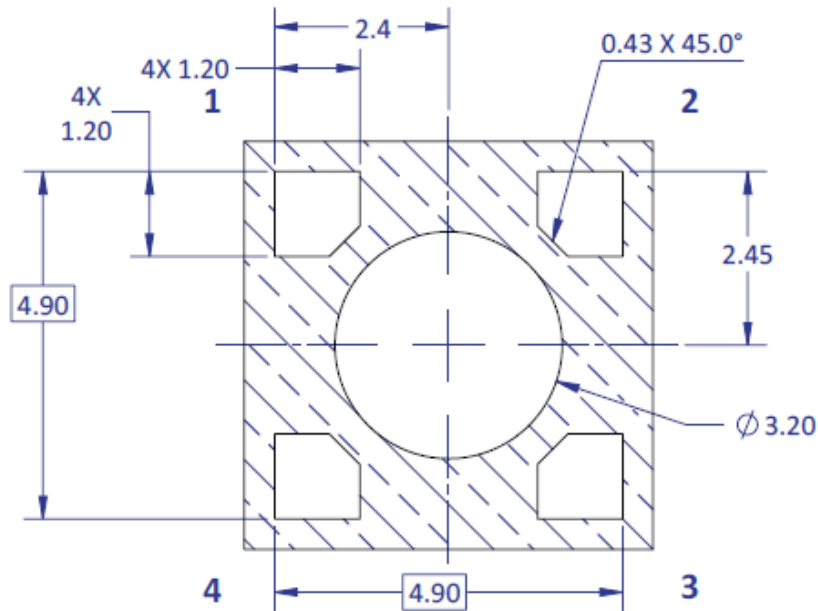

Figure 2b: Recommended solder mask opening for anode, cathode, and thermal pad

Note for Figure 2b:

1. Unless otherwise noted, the tolerance = ± 0.20 mm.

Recommended 8mil Stencil Apertures Layout (mm)

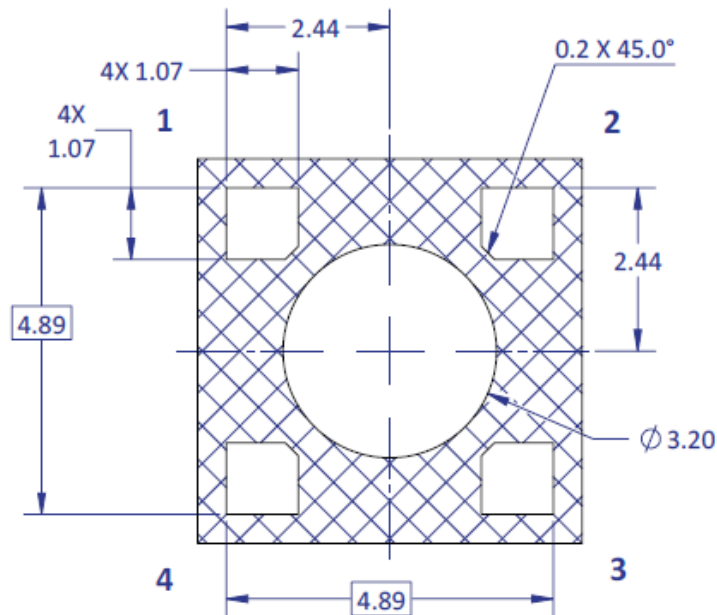

Figure 2c: Recommended solder mask opening for anode, cathode, and thermal pad

Note for Figure 2c:

1. Unless otherwise noted, the tolerance = ± 0.20 mm.

Reflow Soldering Profile

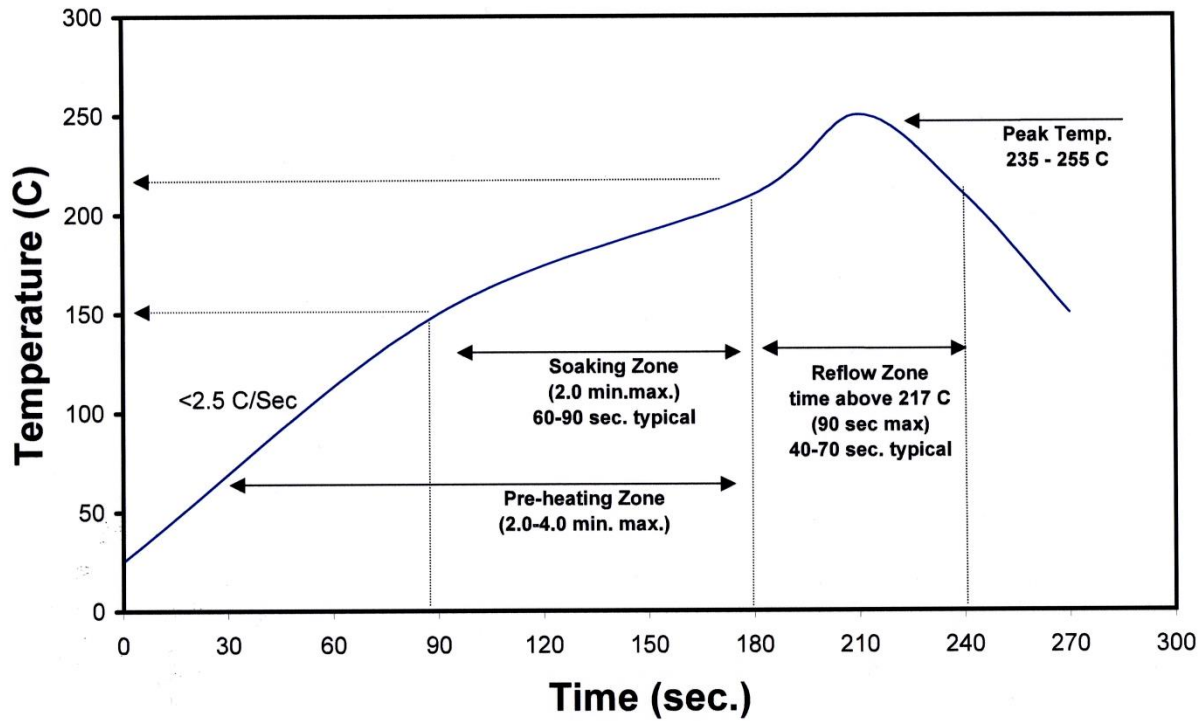

Figure 3: Reflow soldering profile for lead free soldering.

Typical Radiation Pattern

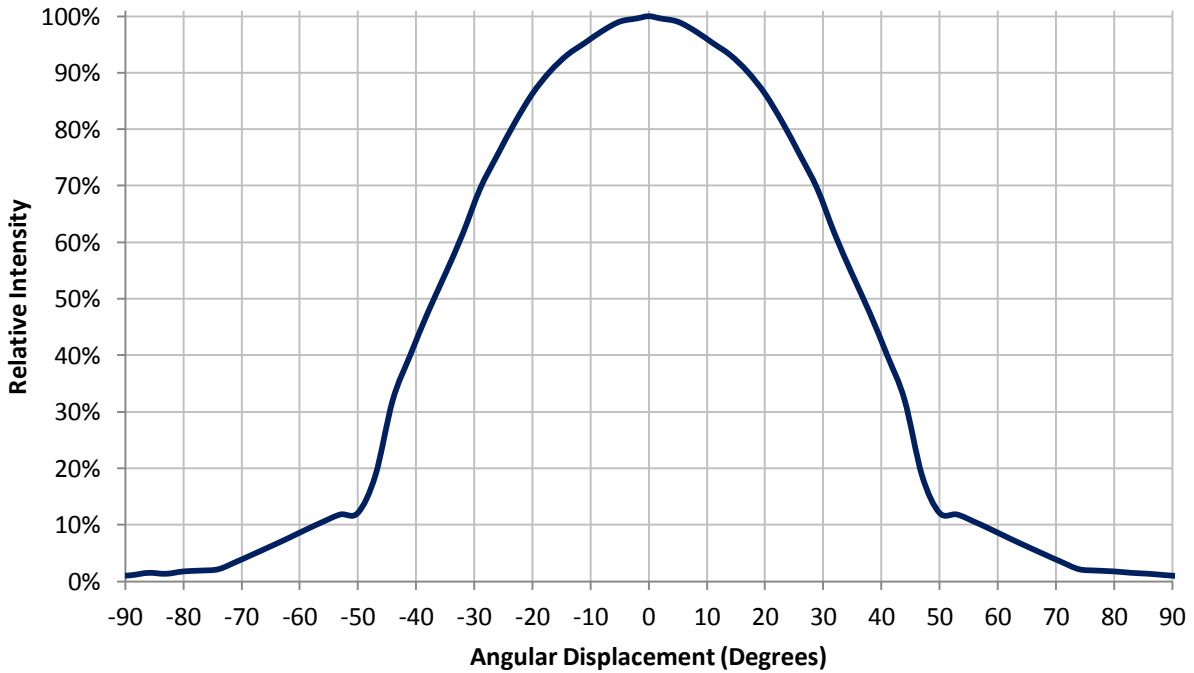

Figure 4: Typical representative spatial radiation pattern

Typical Relative Spectral Power Distribution

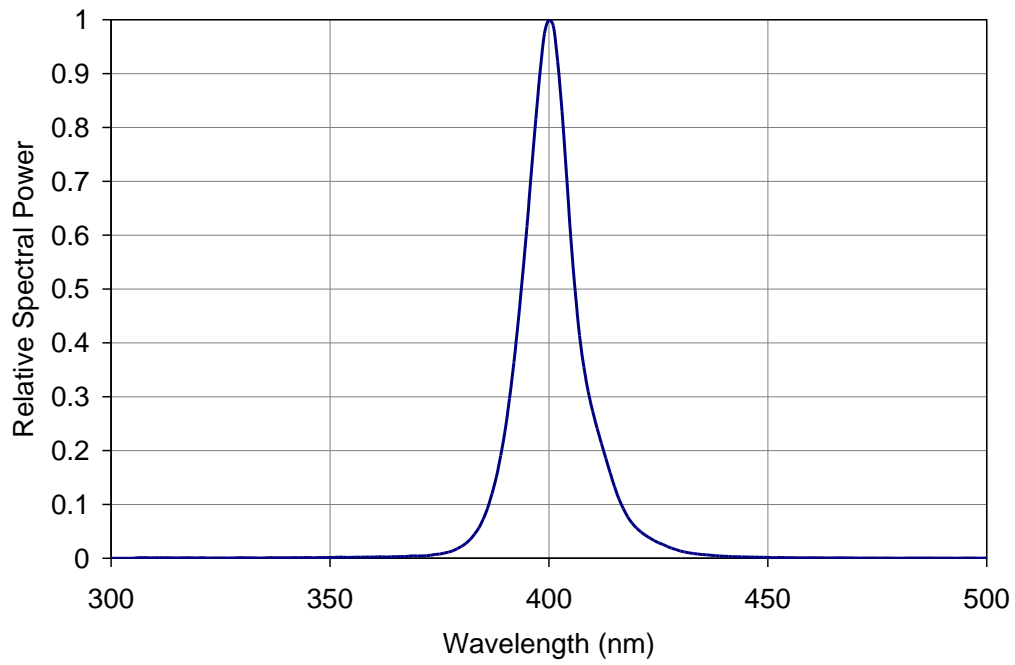

Figure 5: Typical relative spectral power vs. wavelength @ $T_c = 25^\circ\text{C}$.

Typical Peak Wavelength Shift over Temperature

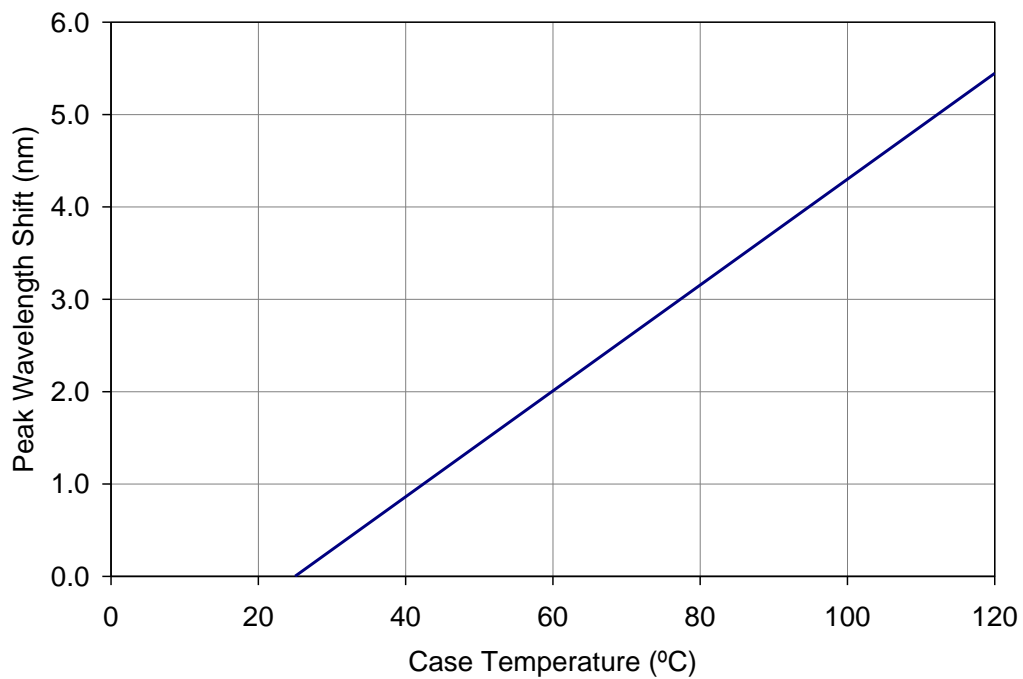

Figure 6: Typical peak wavelength shift vs. case temperature.

Typical Normalized Radiant Flux

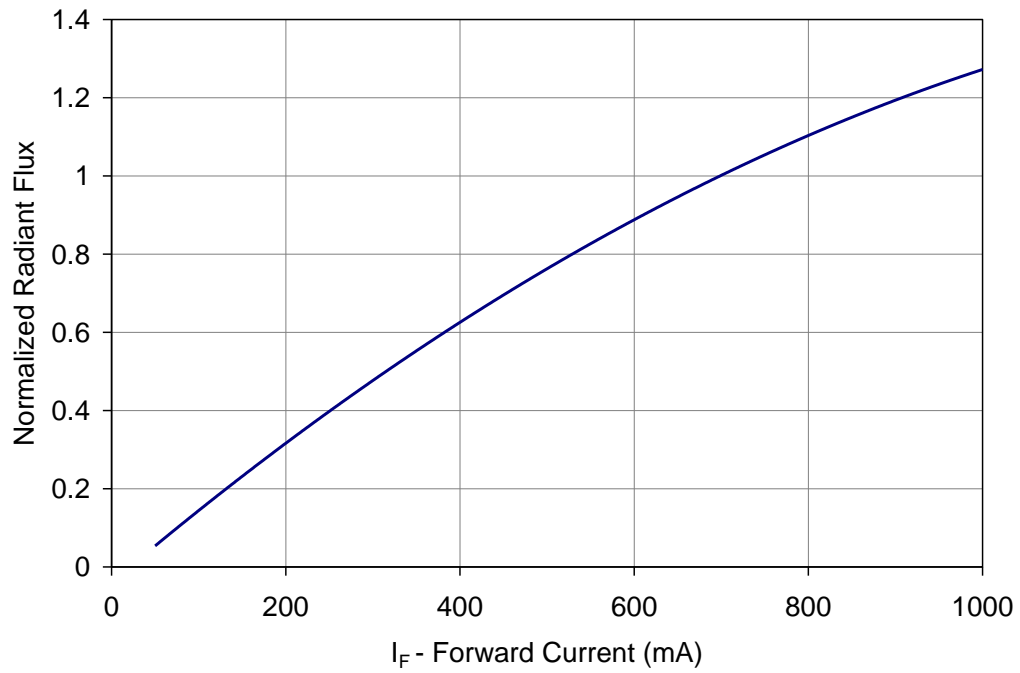

Figure 7: Typical normalized radiant flux vs. forward current @ $T_c = 25^\circ\text{C}$.

Typical Normalized Radiant Flux over Temperature

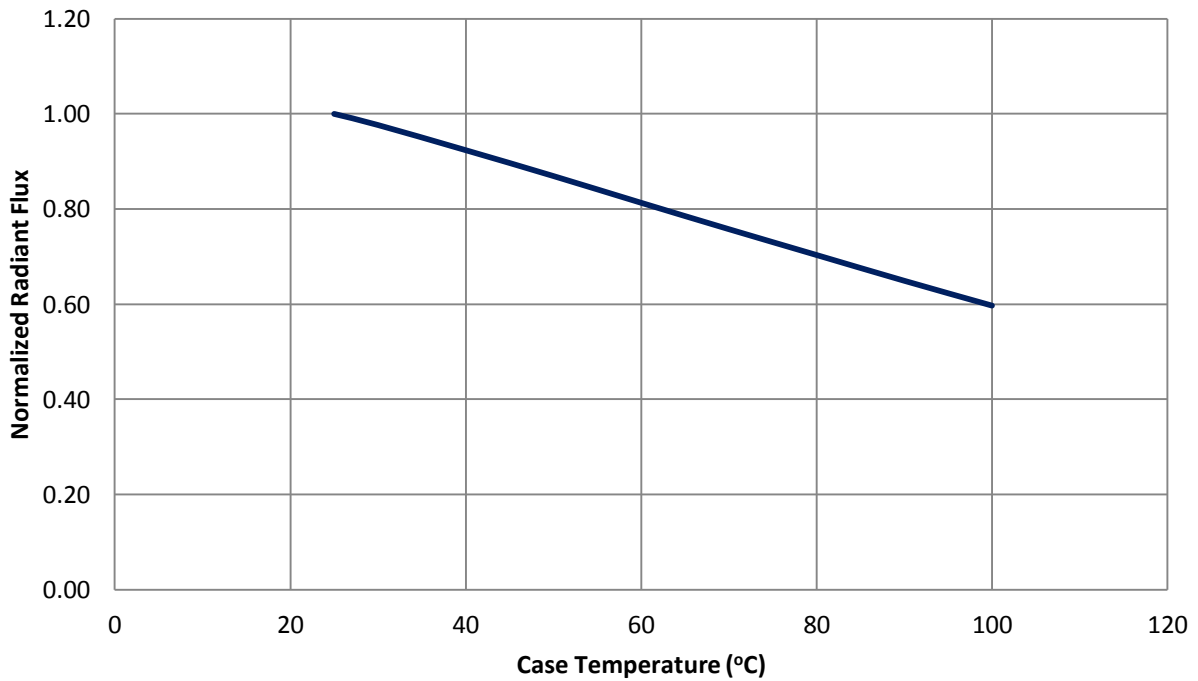

Figure 8: Typical normalized radiant flux vs. case temperature @ 700mA

Typical Forward Current Characteristics

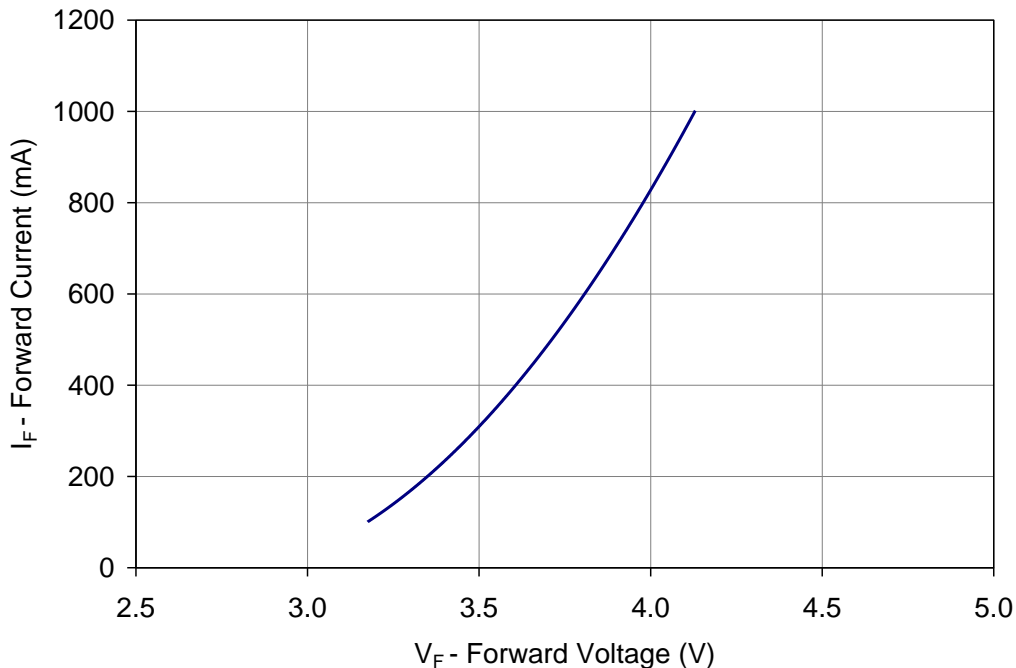

Figure 9: Typical forward current vs. forward voltage @ $T_c = 25^\circ\text{C}$.

Current De-rating

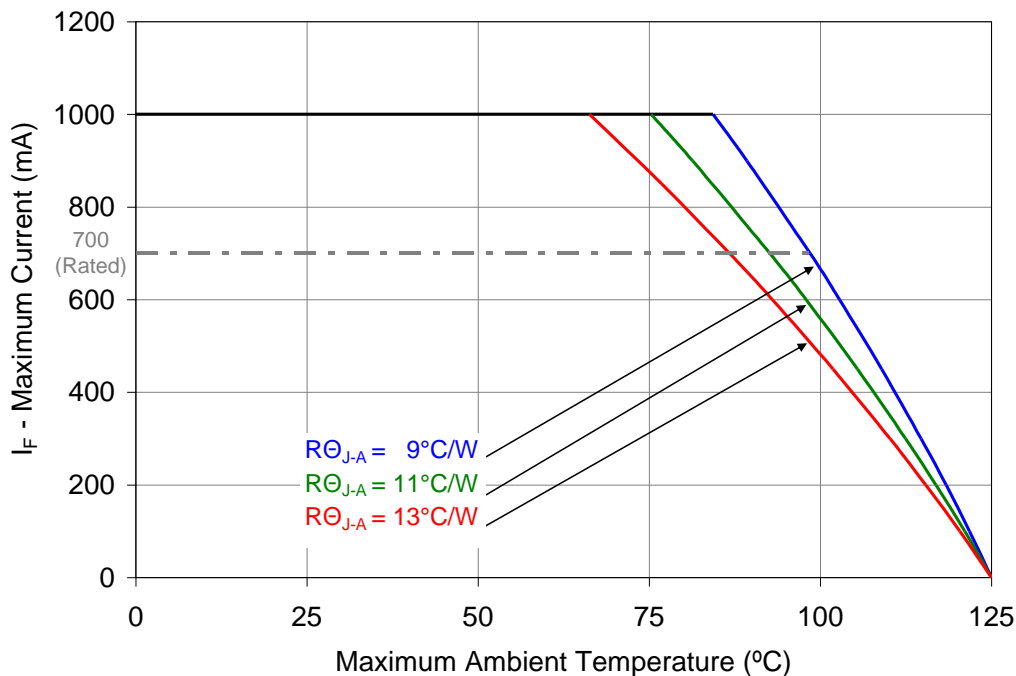

Figure 10: Maximum forward current vs. ambient temperature based on $T_{j(\text{MAX})} = 125^\circ\text{C}$.

Notes for Figure 10:

1. $R_{\theta_{j-c}}$ [Junction to Case Thermal Resistance] for the LZ1-00UA00 is typically 4.2°C/W .
2. $R_{\theta_{j-a}}$ [Junction to Ambient Thermal Resistance] = $R_{\theta_{j-c}}$ + $R_{\theta_{c-a}}$ [Case to Ambient Thermal Resistance].

Emitter Tape and Reel Specifications (mm)

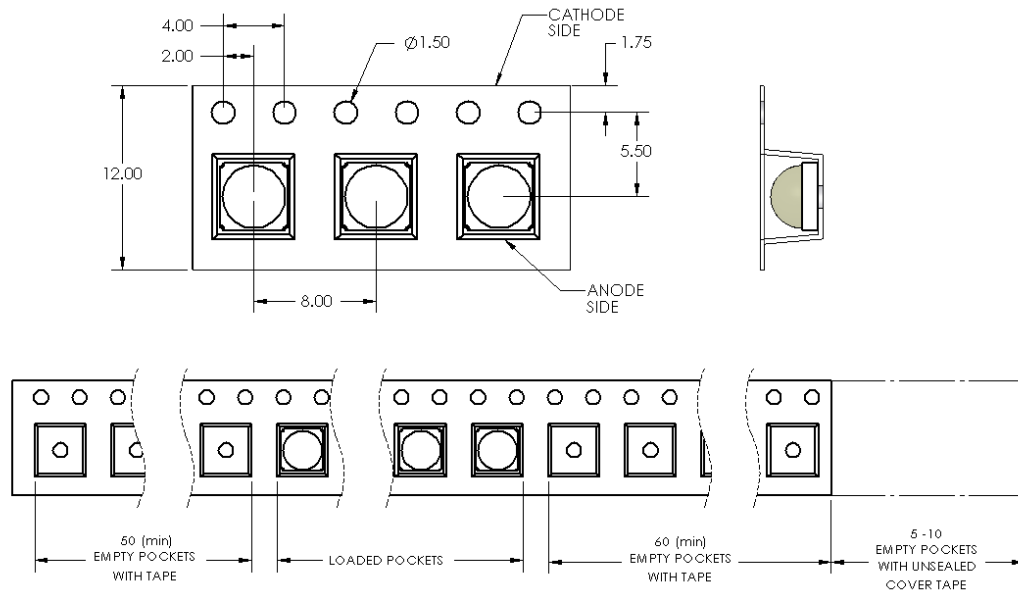

Figure 11: Emitter carrier tape specifications (mm).

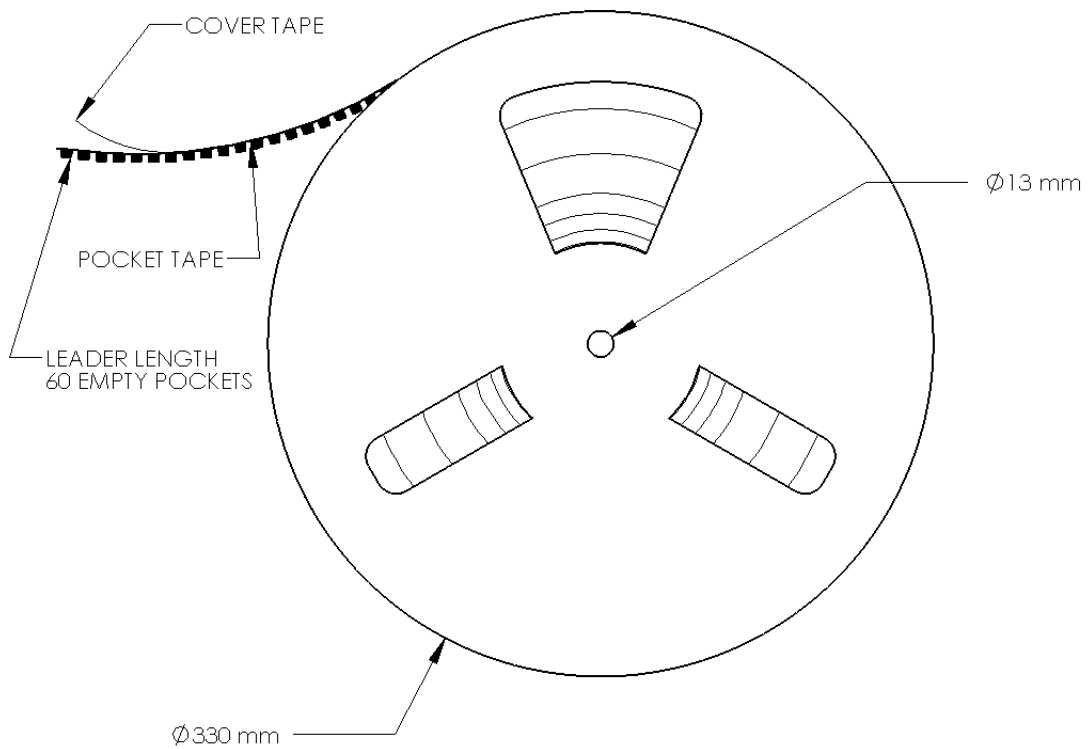

Figure 12: Emitter reel specifications (mm).

Notes:

1. Reel quantity minimum: 100 emitters. Reel quantity maximum: 2000 emitters

LZ1 MCPCB Family

Part number	Type of MCPCB	Diameter (mm)	Emitter + MCPCB Thermal Resistance (°C /W)	Typical V_f (V)	Typical I_f (mA)
LZ1-1xxxxx	1-channel Star	19.9	$4.2 + 1.5 = 5.7$	3.9	700
LZ1-3xxxxx	1-channel Mini	11.5	$4.2 + 2.0 = 6.2$	3.9	700

Mechanical Mounting of MCPCB

- MCPCB bending should be avoided as it will cause mechanical stress on the emitter, which could lead to substrate cracking and subsequently LED dies cracking.
- To avoid MCPCB bending:
 - Special attention needs to be paid to the flatness of the heat sink surface and the torque on the screws.
 - Care must be taken when securing the board to the heat sink. This can be done by tightening three M3 screws (or #4-40) in steps and not all the way through at once. Using fewer than three screws will increase the likelihood of board bending.
 - It is recommended to always use plastics washers in combinations with the three screws.
 - If non-taped holes are used with self-tapping screws, it is advised to back out the screws slightly after tightening (with controlled torque) and then re-tighten the screws again.

Thermal interface material

- To properly transfer heat from LED emitter to heat sink, a thermally conductive material is required when mounting the MCPCB on to the heat sink.
- There are several varieties of such material: thermal paste, thermal pads, phase change materials and thermal epoxies. An example of such material is Electrolube EHTC.
- It is critical to verify the material's thermal resistance to be sufficient for the selected emitter and its operating conditions.

Wire soldering

- To ease soldering wire to MCPCB process, it is advised to preheat the MCPCB on a hot plate of 125-150°C. Subsequently, apply the solder and additional heat from the solder iron will initiate a good solder reflow. It is recommended to use a solder iron of more than 60W.
- It is advised to use lead-free, no-clean solder. For example: SN-96.5 AG-3.0 CU 0.5 #58/275 from Kester (pn: 24-7068-7601)

LZ1-1xxxxx

1 channel, Standard Star MCPCB (1x1) Dimensions (mm)

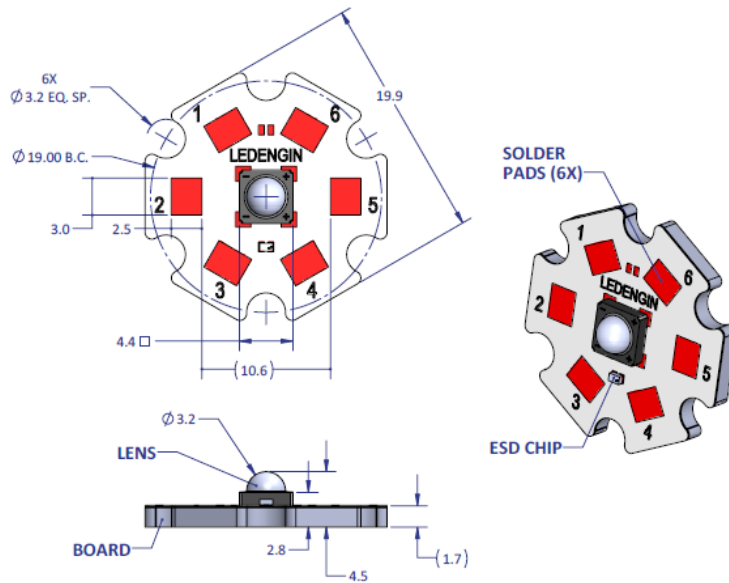

Notes:

- Unless otherwise noted, the tolerance = ± 0.2 mm.
- Slots in MCPCB are for M3 or #4-40 mounting screws.
- LED Engin recommends plastic washers to electrically insulate screws from solder pads and electrical traces.
- LED Engin recommends using thermal interface material when attaching the MCPCB to a heat sink.
- The thermal resistance of the MCPCB is: $R_{\theta C-B}$ 1.5°C/W

Components used

MCPCB:	HT04503	(Bergquist)
ESD/TVS Diode:	BZT52C5V1LP-7	(Diodes, Inc., for 1 LED die)
	VBUS05L1-DD1	(Vishay Semiconductors, for 1 LED die)

Pad layout			
Ch.	MCPCB Pad	String/die	Function
1	1,2,3	1/A	Cathode -
	4,5,6		Anode +

LZ1-3xxxxx

1 channel, Mini Round MCPCB (1x1) Dimensions (mm)

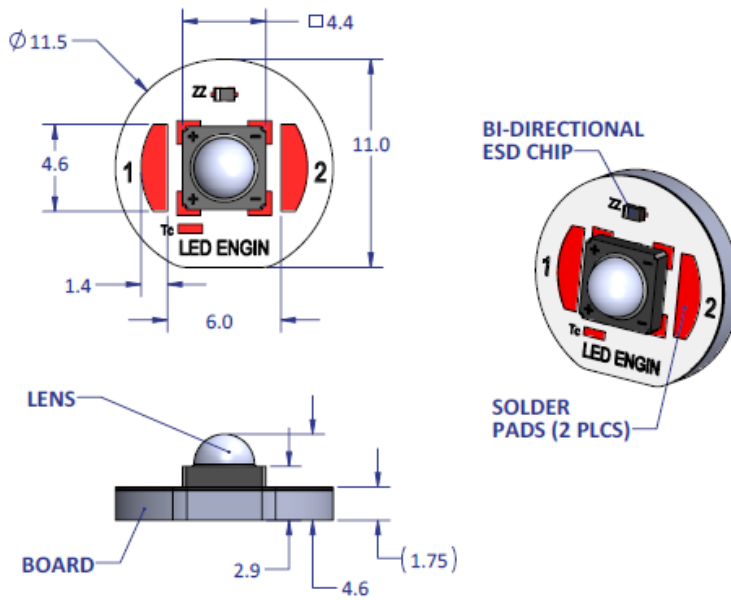

Notes:

- Unless otherwise noted, the tolerance = ± 0.20 mm.
- LED Engin recommends using thermal interface material when attaching the MCPCB to a heat sink.
- The thermal resistance of the MCPCB is: θ_{JC-B} 2.0°C/W

Components used

MCPCB: HT04503 (Bergquist)
 ESD/TVS Diode: BZT52C5V1LP-7 (Diodes, Inc., for 1 LED die)
 VBUS05L1-DD1 (Vishay Semiconductors, for 1 LED die)

Pad layout			
Ch.	MCPCB Pad	String/die	Function
1	1	1/A	Anode +
	2		Cathode -

Company Information

LED Engin, Inc., based in California’s Silicon Valley, specializes in ultra-bright, ultra compact solid state lighting solutions allowing lighting designers & engineers the freedom to create uncompromised yet energy efficient lighting experiences. The LuxiGen™ Platform — an emitter and lens combination or integrated module solution, delivers superior flexibility in light output, ranging from 3W to 90W, a wide spectrum of available colors, including whites, multi-color and UV, and the ability to deliver upwards of 5,000 high quality lumens to a target. The small size combined with powerful output allows for a previously unobtainable freedom of design wherever high-flux density, directional light is required. LED Engin’s packaging technologies lead the industry with products that feature lowest thermal resistance, highest flux density and consummate reliability, enabling compact and efficient solid state lighting solutions.

LED Engin is committed to providing products that conserve natural resources and reduce greenhouse emissions.

LED Engin reserves the right to make changes to improve performance without notice.

Please contact sales@ledengin.com or (408) 922-7200 for more information.

Looking for pricing, stock, or lifecycle information?

Click below to explore more details on WIN SOURCE:

 [View LZ1-00UA00-00U8 on WIN SOURCE](#)

 [LED Engin Inc. Information](#)

Optimize Your Supply Chain with WIN SOURCE Solutions

-  Global Sourcing Solution
-  Obsolete Management
-  Cost Control Management
-  Shortage Management
-  Alternative Solution
-  Excess Inventory Management