

LV8805SV



ON Semiconductor®

www.onsemi.com

Bi-CMOS LSI

Fan Motor Driver for PC and Server

Overview

The LV8805SV is a motor driver for PC and server fans.

Feature

- Direct PWM three-phase sensorless motor driver.

Typical Applications

- PC and Server
- Refrigerator
- Server
- Desktop Computer

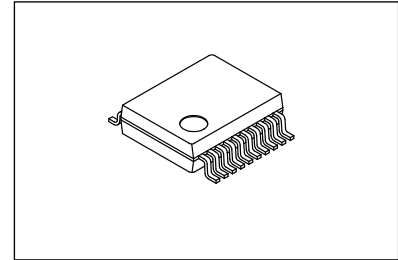

SSOP20J (225mil)

Specifications

Absolute Maximum Ratings at $T_a = 25^\circ\text{C}$

Parameter	Symbol	Conditions	Ratings	Unit
V_{CC} maximum supply voltage	$V_{CC\ max}$		16	V
VG maximum supply voltage	$V_{G\ max}$		21	V
OUT pin withstand voltage	$V_{OUT\ max}$		16	V
OUT pin maximum output	$I_{OUT\ max}$	UO pin, VO pin, WO pin	1.2	A
SOFTST pin withstand voltage	$V_{SOFTST\ max}$		6	V
FR pin withstand voltage	$V_{FR\ max}$		6	V
PWMIN pin withstand voltage	$V_{PWMIN\ max}$		6	V
FG output pin withstand voltage	$V_{FG\ max}$		16	V
FG pin output current	$I_{FG\ max}$		5	mA
RD output pin withstand voltage	$V_{RD\ max}$		16	V
RD pin output current	$I_{RD\ max}$		5	mA
Allowable Power dissipation 1	$P_{d\ max1}$	Independent IC	0.3	W
Allowable Power dissipation 2	$P_{d\ max2}$	Mounted on designated board *1	0.95	W
Operating temperature	T_{opr}		-40 to +95	$^\circ\text{C}$
Storage temperature	T_{stg}	*2	-55 to +150	$^\circ\text{C}$

*1: When mounted on the designated 76.1mm × 114.3mm × 1.6mm, glass epoxy board (single-layer)

*2: Do not exceed $T_{jmax}=150^\circ\text{C}$.

Caution 1) Absolute maximum ratings represent the value which cannot be exceeded for any length of time.

Caution 2) Even when the device is used within the range of absolute maximum ratings, as a result of continuous usage under high temperature, high current, high voltage, or drastic temperature change, the reliability of the IC may be degraded. Please contact us for the further details.

Stresses exceeding those listed in the Maximum Ratings table may damage the device. If any of these limits are exceeded, device functionality should not be assumed, damage may occur and reliability may be affected.

ORDERING INFORMATION

See detailed ordering and shipping information on page 11 of this data sheet.

LV8805SV

Recommended Operating Conditions at Ta = 25°C

Parameter	Symbol	Conditions	Ratings	Unit
V _{CC} supply voltage	V _{CC}		6 to 15	V
SOFTST input voltage range	V _{SOFTST}		0 to V _{REG}	V
FR input voltage range	V _{FR}		0 to V _{REG}	V
MINSNP input voltage range	V _{MINSNP}		0 to V _{REG}	V

Functional operation above the stresses listed in the Recommended Operating Ranges is not implied. Extended exposure to stresses beyond the Recommended Operating Ranges limits may affect device reliability.

Electrical Characteristics at Ta = 25°C, V_{CC} = 12V, unless otherwise specified

Parameter	Symbol	Conditions	Ratings			Unit
			min	typ	max	
Circuit current 1	I _{CC1}			2.6	3.6	mA
Charge pump block						
Charge pump output voltage	V _{VG}			17		V
Regulator block						
5V regulator voltage	V _{VREG}		4.75	5	5.25	V
Output on resistance						
Sum of high-/low-side output transistor on resistance	R _{on (H+L)}	I _O = 0.7A, V _{CC} = 12V, V _G = 17V		1.2	2	Ω
Startup oscillator (OSC) pin						
OSC pin charge current	I _{OSCC}			-2.5		μA
OSC pin discharge current	I _{OSCD}			2.5		μA
PWM input (PWMIN) pin						
High-level input voltage range	V _{PWMINH}		2.3		V _{REG}	V
Low-level input voltage range	V _{PWMINL}		0		1	V
Range of PWM input frequency	f _{PWMIN}		15		60	kHz
Minimum pulse width	T _{MINPW}	Input HIGH voltage 5[V] and input LOW voltage 0[V]			0.2	μs
Duty cycle range is determined by $(T_{MINPW} \times f_{PWMIN}) \times 100\%$ for minimum $(1 - T_{MINPW} \times f_{PWMIN}) \times 100\%$ for maximum When f _{PWMIN} = 60[kHz], the input PWM duty cycle range = 1.2% - 98.8% When f _{PWMIN} = 50[kHz], the input PWM duty cycle range = 1.0% - 99.0% When f _{PWMIN} = 25[kHz], the input PWM duty cycle range = 0.5% - 99.5% When f _{PWMIN} = 15[kHz], the input PWM duty cycle range = 0.3% - 99.7%						
Forward/reverse switching pin						
High-level input voltage range	V _{FRH}	Order of current application : U _{OUT} →V _{OUT} →W _{OUT}	2.3		V _{REG}	V
Low-level input voltage range	V _{FRL}	Order of current application : U _{OUT} →W _{OUT} →V _{OUT}	0		1	V
FG and RD output pins						
FG output pin low-level voltage	V _{FG}	When I _O is 2mA		0.25	0.35	V
FG output pin leak voltage	I _{LFG}	When V _{FG} is 16V			1	μA
RD output pin low-level voltage	V _{RD}	When I _O is 2mA		0.25	0.35	V
RD output pin leak voltage	I _{LRD}	When V _{RD} is 16V			1	μA
Current limiter circuit						
Limiter voltage	V _{RF}	Limit current set to 1A when R _F is 0.25Ω.	0.225	0.25	0.275	V
Constraint protection circuit						
CT pin high-level voltage	V _{CTH}		2.25	2.8	2.95	V
CT pin low-level voltage	V _{CTL}		0.43	0.5	0.65	V
CT pin charge current	I _{CTC}		-2.9	-2.5	-2.1	μA
CT pin discharge current	I _{CTD}		0.21	0.25	0.32	μA
ICT charge/discharge ratio	R _{CT}		7	10	13	

Continued on next page.

LV8805SV

Continued from preceding page.

Parameter	Symbol	Conditions	Ratings			Unit
			min	typ	max	
Soft start circuit						
Soft start releasing voltage	V _{SOFTST}			2.5		V
SOFTST pin charge current	I _{SOFTST}			0.6		μA
Thermal protection circuit						
Thermal protection circuit operating temperature	TSD	Design target *	150	180	210	°C

* : Design target value and no measurement is made. The thermal protection circuit is incorporated to protect the IC from burnout or thermal destruction. Since it operates outside the IC's guaranteed operating range, the customer's thermal design should be performed so that the thermal protection circuit will not be activated when the fan is running under normal operating conditions.

Product parametric performance is indicated in the Electrical Characteristics for the listed test conditions, unless otherwise noted. Product performance may not be indicated by the Electrical Characteristics if operated under different conditions.

Package Dimensions

unit : mm

SSOP20J (225mil)
 CASE 565AP
 ISSUE A

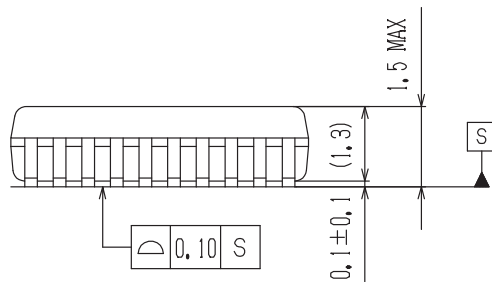
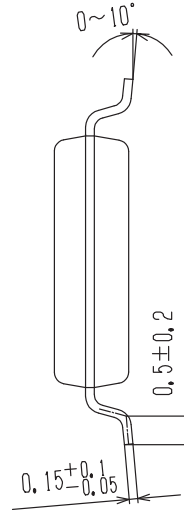
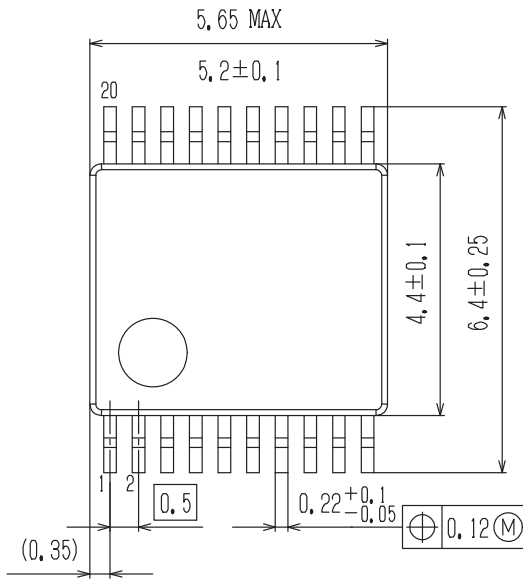

SOLDERING FOOTPRINT*

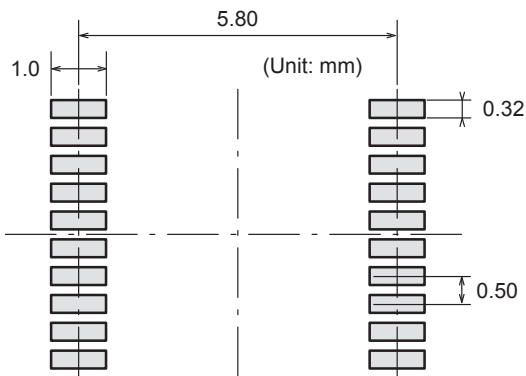

NOTE: The measurements are not to guarantee but for reference only.

*For additional information on our Pb-Free strategy and soldering details, please download the ON Semiconductor Soldering and Mounting Techniques Reference Manual, SOLDERRM/D.

GENERIC MARKING DIAGRAM*

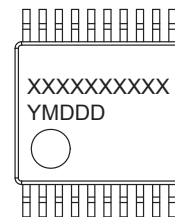

XXXXX = Specific Device Code
 Y = Year
 M = Month
 DDD = Additional Traceability Data

*This information is generic. Please refer to device data sheet for actual part marking. Pb-Free indicator, "G" or microdot "▪", may or may not be present.

LV8805SV

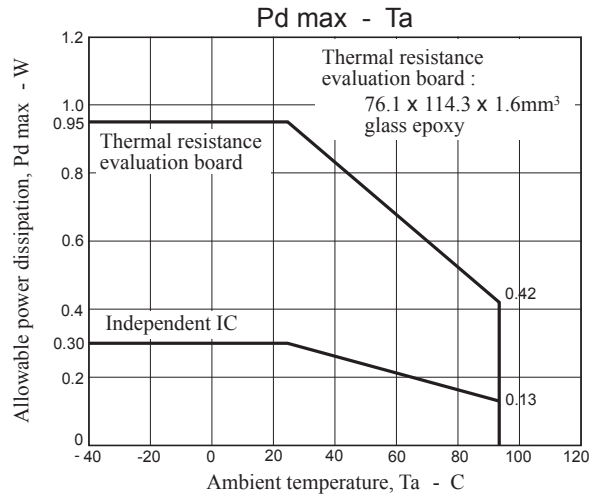

Pin Assignment

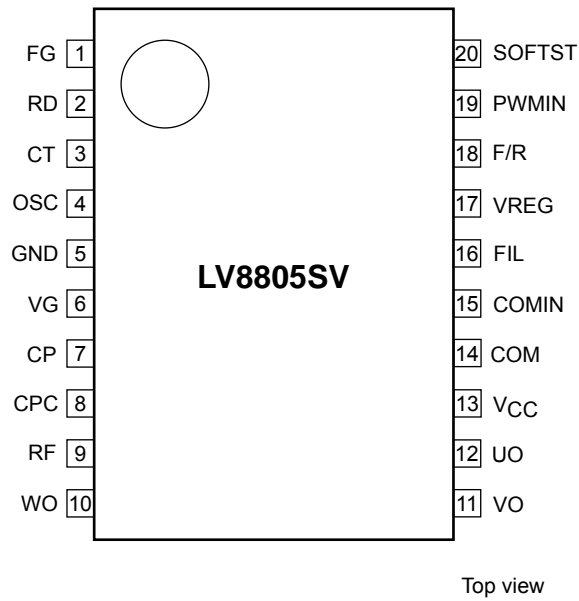

Block Diagram

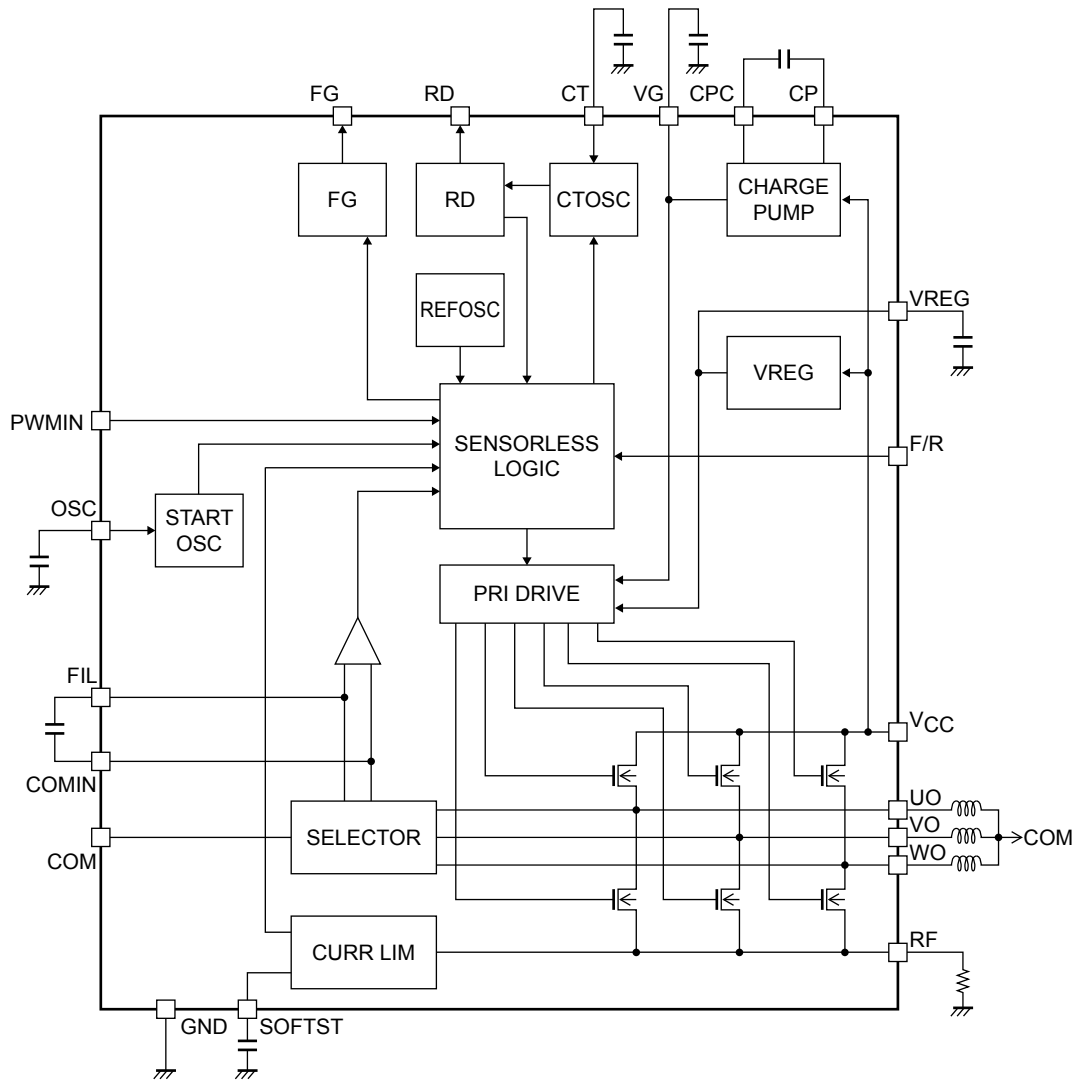

LV8805SV

Pin Function

Pin No.	Pin name	Function	Equivalent circuit
1	FG	FG pulse output. This pin outputs a Hall sensor system equivalent pulse signal.	
2	RD	Motor lockup detection output. Output is fixed high when motor is locked up.	
3	CT	Motor lockup detection time setting. When the motor lockup condition is detected, the protection time period before the protection circuit is activated is set by connecting a capacitor between this pin and ground.	
4	OSC	Motor startup frequency setting. A capacitor must be connected between this pin and ground. The startup frequency is adjusted by controlling the charge/discharge current and capacitance of the capacitor.	
5	GND	GND pin	
6	VG	Charge pump step-up voltage output. A capacitor must be connected between this pin and the V _{CC} pin or ground.	
7	CP	Charge pump step-up pulse output pin. A capacitor must be connected between this pin and the CPC pin (pin 8).	
8	CPC	Charge pump step-up pin. A capacitor must be connected between this pin and the CP pin (pin 7).	
13	V _{CC}	Power supply for the IC and motor. Capacitors must be connected between these pins and ground.	
12	UO	Output pins. Connect these pins to the U, V, and W of the motor coil.	
11	VO		
10	WO		
9	RF	Output current detection pins. The drive current is detected by connecting a resistor between these pins and ground.	

Continued on next page.

LV8805SV

Continued from preceding page.

Pin No.	Pin name	Function	Equivalent circuit
14	COM	Motor middle point connection.	
15	COMIN	Motor position detection comparator filter pin. A capacitor must be connected between this pin and the FIL pin (pin 16).	
16	FIL	Motor position detection comparator filter pin. A capacitor must be connected between this pin and the COMIN pin (pin 15).	
17	VREG	Regulator voltage (5V) output. A capacitor must be connected between these pins and ground.	
18	F/R	Motor rotation direction switching. A high-level input causes current to flow into the motor in the order of U, V, and W and a low-level input in the order of U, W, and V. Changing the order of current application turns the motor in the opposite direction.	
19	PWMIN	PWM signal input pin. "H" The output transistor is turned on by the level voltage input. "L" The output transistor is turned off by the level voltage input, and the motor stops. The speed of the motor is controlled by controlling Duty of the input signal. When the pin opens, the motor becomes all velocities.	
20	SOFTST	Soft start time setting. The motor can be started smoothly by connecting a capacitor between this pin and ground.	

Application Circuit Example

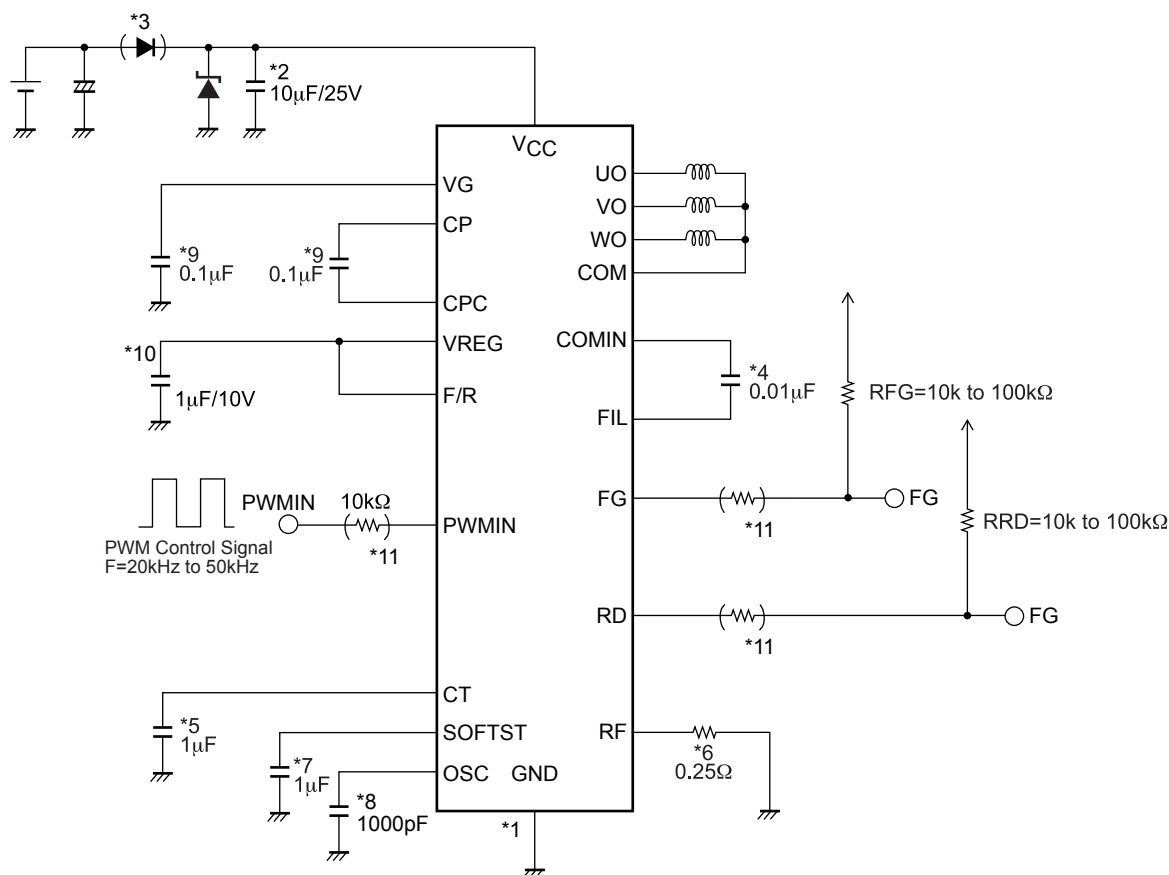

*1. Power supply and GND wiring

The GND is connected to the control circuit power supply system.

*2. Power-side power stabilization capacitor

For the power-side power stabilization capacitor, use a capacitor of 10µF or more.

Connect the capacitor between V_{CC} and GND with a thick and along the shortest possible route.

LV8805SV uses synchronous rectification for high efficiency drive. Synchronous rectification is effective for heat reduction and higher efficiency. However, it may increase supply voltage.

If the supply voltage shall increase, make sure that it does not exceed the maximum ratings by inserting a zener diode between power supply and GND.

*3. Reverse connection protection diode

This diode protects reverse connection.

Insert a diode between power supply and V_{CC} pin to protect the IC from destruction due to reverse connection.

Connection of this diode is not necessary required.

*4. COMIN and FIL pins

These pins are used to connect the filter capacitor. The LV8805SV uses the back EMF signal generated when the motor is running to detect the information on the rotor position. The IC determines the timing at which the output block applies current to the motor based on the position information obtained here. Insert a filter capacitor with a capacitance ranging from (1,000pF to 10,000pF) between the COMIN pin and FIL pin to prevent any motor startup misoperation that is caused by noise. However, care must be taken since an excessively high capacitance will give rise to deterioration in efficiency and delays in the output power-on timing while the motor is running at high speed. Furthermore, connect the capacitor between the COMIN pin and FIL pin as close as possible in order to avoid the effects of noise from other sources.

*5. CT pin

This pin is used to connect the lock detection capacitor.

The constant-current charging and constant-current discharging circuits incorporated cause locking when the pin voltage reaches 2.5V, and releasing the lock protection when it drops to 0.5V. This pin must be connected to the GND when it is not going to be used.

*6. RF pins

These pins are used to set the current limit.

When the pin voltage exceeds 0.25V, the current is limited, and regeneration mode is established. In the application circuit, this voltage is set in such a way that the current limit will be established at 1A.

The calculation formula is given below.

RF resistance = 0.25V/target current limit value

*7. SOFTST pin

This pin is used to set the soft start.

By connecting a capacitor between this pin and GND, the motor speed can be increased gradually.

When the pin voltage exceeds 2.5V, the soft start is released, and the LV8805SV is switched to normal control.

If the soft start function is not going to be used, connect the pin to the VREG pin.

*8. OSC pin

This pin is used to connect the capacitor for setting the startup frequency.

A capacitor with a capacitance ranging from about 500pF to 2,200pF (recommendation) must be connected between this pin and GND.

The OSC pin determines the motor startup frequency, so be sure to connect a capacitor to it.

<How to select the capacitance>

Select a capacitance value that will result in the shortest possible startup time for achieving the target speed and produce minimal variations in the startup time. If the capacitance is too high, variations in the startup time will increase; conversely, if it is too low, the motor may idle. The optimum OSC constant depends on the motor characteristics and startup current, so be sure to recheck them when the type of motor used or circuit specifications are changed.

*9. VG, CP, and CPC pins

These pins are used to connect the capacitors to generate the pre-drive voltage and stabilize the pre-drive power supply.

Be sure to connect these capacitors in order to generate the drive voltage for the high-side (upper) output DMOS transistor.

*10. VREG pins

These are the control system power supply pin and regulator output pin, which create the power supply of the control unit. Be sure to connect a capacitor between this pin and GND in order to stabilize control system operation.

Since these pins are used to supply current for control and generate the charge pump voltage, connect a capacitor with a capacitance that is higher than that of the capacitor connected to the charge pump.

Both the VREG pins (pins 3 and 4) must be short-circuited on the print pattern.

*11. Pin protection resistor

It is recommended that resistors higher than 1k Ω are connected serially to protect pins against misconnection such as GND open and reverse connection.



ORDERING INFORMATION

Device	Package	Shipping (Qty / Packing)
LV8805SV-MPB-H	SSOP20J (225mil) (Pb-Free / Halogen Free)	90 / Fan-Fold
LV8805SV-TLM-H	SSOP20J (225mil) (Pb-Free / Halogen Free)	2000 / Tape & Reel

ON Semiconductor and the ON logo are registered trademarks of Semiconductor Components Industries, LLC (SCILLC) or its subsidiaries in the United States and/or other countries. SCILLC owns the rights to a number of patents, trademarks, copyrights, trade secrets, and other intellectual property. A listing of SCILLC's product/patent coverage may be accessed at www.onsemi.com/site/pdf/Patent-Marking.pdf. SCILLC reserves the right to make changes without further notice to any products herein. SCILLC makes no warranty, representation or guarantee regarding the suitability of its products for any particular purpose, nor does SCILLC assume any liability arising out of the application or use of any product or circuit, and specifically disclaims any and all liability, including without limitation special, consequential or incidental damages. "Typical" parameters which may be provided in SCILLC data sheets and/or specifications can and do vary in different applications and actual performance may vary over time. All operating parameters, including "Typicals" must be validated for each customer application by customer's technical experts. SCILLC does not convey any license under its patent rights nor the rights of others. SCILLC products are not designed, intended, or authorized for use as components in systems intended for surgical implant into the body, or other applications intended to support or sustain life, or for any other application in which the failure of the SCILLC product could create a situation where personal injury or death may occur. Should Buyer purchase or use SCILLC products for any such unintended or unauthorized application, Buyer shall indemnify and hold SCILLC and its officers, employees, subsidiaries, affiliates, and distributors harmless against all claims, costs, damages, and expenses, and reasonable attorney fees arising out of, directly or indirectly, any claim of personal injury or death associated with such unintended or unauthorized use, even if such claim alleges that SCILLC was negligent regarding the design or manufacture of the part. SCILLC is an Equal Opportunity/Affirmative Action Employer. This literature is subject to all applicable copyright laws and is not for resale in any manner.

Looking for pricing, stock, or lifecycle information?

Click below to explore more details on WIN SOURCE:

-  [View LV8805SV-TLM-H on WIN SOURCE](#)
-  [ON Semiconductor](#) Information

Optimize Your Supply Chain with WIN SOURCE Solutions

-  Global Sourcing Solution
-  Obsolete Management
-  Cost Control Management
-  Shortage Management
-  Alternative Solution
-  Excess Inventory Management