



**THE DATASHEET OF  
LV8731V-TLM-H**



# LV8731V

---

## PWM Constant-Current Control Stepper Motor Driver

### Monolithic Linear IC

#### Overview

The LV8731V is a 2-channel H-bridge driver IC that can switch a stepper motor driver, which supports micro-step drive with 1/16-step resolution, and two channels of a brushed motor driver, which supports forward, reverse, brake, and standby of a motor. It is ideally suited for driving brushed DC motors and stepper motors used in office equipment and amusement applications.

#### Function

- Single-channel PWM Current Control Stepper Motor Driver (Selectable with DC Motor Driver Channel 2) Incorporated
- BiCDMOS Process IC
- Low on Resistance (Upper Side: 0.3  $\Omega$ ; Lower Side: 0.25  $\Omega$ ; Total of Upper and Lower: 0.55  $\Omega$ ;  $T_A = 25^\circ\text{C}$ ,  $I_O = 2\text{ A}$ )
- Micro-step Mode can be Set to Full-step, Half-step, Quarter-step, or 1/16-step
- Excitation Step Proceeds Only by Step Signal Input
- Motor Current Selectable in Four Steps
- Output Short-circuit Protection Circuit (Selectable from Latch-type or Auto-reset-type) Incorporated
- Unusual Condition Warning Output Pins
- No Control Power Supply Required



ON Semiconductor®

[www.onsemi.com](http://www.onsemi.com)

---

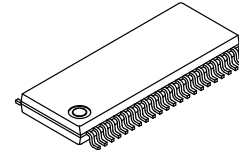

SSOP44K  
CASE 940AF

---

#### MARKING DIAGRAM

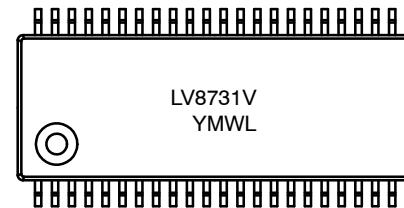

Y = Year of Production, Last Number  
M = Assembly Operation Month  
WL = Wafer Lot Number

---

#### ORDERING INFORMATION

See detailed ordering and shipping information in the package dimensions section on page 26 of this data sheet.

---

# LV8731V

## SPECIFICATIONS

### ABSOLUTE MAXIMUM RATINGS at $T_A = 25^\circ\text{C}$

Parameter	Symbol	Conditions	Ratings	Unit
Supply Voltage	VM max	VM, VM1, VM2	36	V
Output Peak Current	$I_{O\text{ peak}}$	$T_w \leq 10\text{ ms}$ , duty 20%, Per 1ch	2.5	A
Output Current	$I_{O\text{ max}}$	Per 1ch	2	A
Logic Input Voltage	$V_{IN}$	ATT1, ATT2, EMM, RST/BLK, STEP/DC22, FR/DC21, MD2/DC12, MD1/DC11, DM, OE, ST	-0.3 to +6	V
MONI/EMO Input Voltage	Vmoni/Vemo		-0.3 to +6	V
Allowable Power Dissipation	Pd max	(Note 1)	3.25	W
Operating Temperature	Topr		-20 to +85	$^\circ\text{C}$
Storage Temperature	Tstg		-55 to +150	$^\circ\text{C}$

Stresses exceeding those listed in the Maximum Ratings table may damage the device. If any of these limits are exceeded, device functionality should not be assumed, damage may occur and reliability may be affected.

1. Specified circuit board : 90.0 mm × 90.0 mm × 1.6 mm, glass epoxy 2-layer board, with backside mounting.
2. Caution 1: Absolute maximum ratings represent the value which cannot be exceeded for any length of time.
3. Caution 2: Even when the device is used within the range of absolute maximum ratings, as a result of continuous usage under high temperature, high current, high voltage, or drastic temperature change, the reliability of the IC may be degraded. Please contact us for the further details.

### ALLOWABLE OPERATING RATINGS $T_A = 25^\circ\text{C}$

Parameter	Symbol	Conditions	Ratings	Unit
Supply Voltage Range	VM	VM, VM1, VM2	9 to 32	V
Logic Input Voltage	$V_{IN}$	ATT1, ATT2, EMM, RST/BLK, STEP/DC22, FR/DC21, MD2/DC12, MD1/DC11, DM, OE, ST	0 to 5.5	V
VREF Input Voltage Range	VREF		0 to 3	V

Functional operation above the stresses listed in the Recommended Operating Ranges is not implied. Extended exposure to stresses beyond the Recommended Operating Ranges limits may affect device reliability.

### ELECTRICAL CHARACTERISTICS $T_A = 25^\circ\text{C}$ , VM = 24 V, VREF = 1.5 V

Parameter	Symbol	Conditions	Ratings			Unit
			Min	Typ	Max	
Standby Mode Current Drain	IMstn	ST = "L", $I(\text{VM}) + I(\text{VM1}) + I(\text{VM2})$		100	400	$\mu\text{A}$
Current Drain	IM	ST = "H", OE = "L", with no load $I(\text{VM}) + I(\text{VM1}) + I(\text{VM2})$		3.2	5	mA
VREG5 Output Voltage	Vreg5	$I_O = -1\text{ mA}$	4.5	5	5.5	V
Thermal Shutdown Temperature	TSD	Design guarantee	150	180	200	$^\circ\text{C}$
Thermal Hysteresis Width	$\Delta\text{TSD}$	Design guarantee		40		$^\circ\text{C}$

### MOTOR DRIVER

Output On Resistance	Ronu	$I_O = 2\text{ A}$ , Upper-side on resistance		0.3	0.4	$\Omega$
	Rond	$I_O = 2\text{ A}$ , Lower-side on resistance		0.25	0.33	$\Omega$
Output Leakage Current	$I_{O\text{ leak}}$				50	$\mu\text{A}$
Diode Forward Voltage	VD	$I_D = -2\text{ A}$		1.2	1.4	V
Logic Pin Input Current	$I_{INL}$	ATT1, ATT2, EMM, RST/BLK, STEP/DC22, FR/DC21, MD2/DC12, MD1/DC11, DM, OE, ST, $V_{IN} = 0.8\text{ V}$	4	8	12	$\mu\text{A}$
	$I_{INH}$	$V_{IN} = 5\text{ V}$	30	50	70	$\mu\text{A}$

# LV8731V

**ELECTRICAL CHARACTERISTICS** (continued)  $T_A = 25^\circ\text{C}$ ,  $V_M = 24\text{ V}$ ,  $V_{REF} = 1.5\text{ V}$

Parameter		Symbol	Conditions	Ratings			Unit
				Min	Typ	Max	
Logic Input Voltage	High	$V_{INh}$	ATT1, ATT2, EMM, RST/BLK, STEP/DC22, FR/DC21, MD2/DC12,	2.0		5.5	V
	Low	$V_{INl}$	MD1/DC11, DM, OE, ST	0		0.8	V
Current Setting Comparator Threshold Voltage (Current Step Switching)	1/16 step resolution	Vtdac0_4W	Step 0 (When initialized: channel 1 comparator level)	0.291	0.3	0.309	V
		Vtdac1_4W	Step 1 (Initial state + 1)	0.291	0.3	0.309	V
		Vtdac2_4W	Step 2 (Initial state + 2)	0.285	0.294	0.303	V
		Vtdac3_4W	Step 3 (Initial state + 3)	0.279	0.288	0.297	V
		Vtdac4_4W	Step 4 (Initial state + 4)	0.267	0.276	0.285	V
		Vtdac5_4W	Step 5 (Initial state + 5)	0.255	0.264	0.273	V
		Vtdac6_4W	Step 6 (Initial state + 6)	0.240	0.249	0.258	V
		Vtdac7_4W	Step 7 (Initial state + 7)	0.222	0.231	0.240	V
		Vtdac8_4W	Step 8 (Initial state + 8)	0.201	0.21	0.219	V
		Vtdac9_4W	Step 9 (Initial state + 9)	0.180	0.189	0.198	V
		Vtdac10_4W	Step 10 (Initial state + 10)	0.157	0.165	0.173	V
		Vtdac11_4W	Step 11 (Initial state + 11)	0.134	0.141	0.148	V
		Vtdac12_4W	Step 12 (Initial state + 12)	0.107	0.114	0.121	V
		Vtdac13_4W	Step 13 (Initial state + 13)	0.080	0.087	0.094	V
		Vtdac14_4W	Step 14 (Initial state + 14)	0.053	0.06	0.067	V
	Vtdac15_4W	Step 15 (Initial state + 15)	0.023	0.03	0.037	V	
	Quarter step resolution	Vtdac0_W	Step 0 (When initialized : channel 1 comparator level)	0.291	0.3	0.309	V
		Vtdac4_W	Step 4 (Initial state + 1)	0.267	0.276	0.285	V
		Vtdac8_W	Step 8 (Initial state + 2)	0.201	0.21	0.219	V
		Vtdac12_W	Step 12 (Initial state + 3)	0.107	0.114	0.121	V
Half step resolution	Vtdac0_H	Step 0 (When initialized : channel 1 comparator level)	0.291	0.3	0.309	V	
	Vtdac8_H	Step 8 (Initial state + 1)	0.201	0.21	0.219	V	
Full step resolution	Vtdac8_F	Step 8' (When initialized : channel 1 comparator level)	0.291	0.3	0.309	V	
Current Setting Comparator Threshold Voltage (Current Attenuation Rate Switching)	Vtatt00	ATT1 = L, ATT2 = L	0.291	0.3	0.309	V	
	Vtatt01	ATT1 = H, ATT2 = L	0.232	0.24	0.248	V	
	Vtatt10	ATT1 = L, ATT2 = H	0.143	0.15	0.157	V	
	Vtatt11	ATT1 = H, ATT2 = H	0.053	0.06	0.067	V	
Chopping Frequency	Fchop	Cchop = 200 pF	40	50	60	kHz	
CHOP Pin Charge/Discharge Current	Ichop		7	10	13	$\mu\text{A}$	
Chopping Oscillation Circuit Threshold Voltage	Vtup		0.8	1	1.2	V	
	Vtdown		0.4	0.5	0.6	V	
VREF Pin Input Current	Iref	$V_{REF} = 1.5\text{ V}$	-0.5			$\mu\text{A}$	
MONI Pin Saturation Voltage	Vsatmon	I <sub>moni</sub> = 1 mA			400	mV	

## CHARGE PUMP

VG Output Voltage	VG		28	28.7	29.8	V
Rise Time	t <sub>ONG</sub>	VG = 0.1 mF, Between CP1-CP2 0.1 $\mu\text{F}$ ST = "H" $\rightarrow$ VG = VM + 4 V		200	500	$\mu\text{s}$
Oscillator Frequency	Fosc		90	125	150	kHz

# LV8731V

**ELECTRICAL CHARACTERISTICS** (continued)  $T_A = 25^\circ\text{C}$ ,  $V_M = 24\text{ V}$ ,  $V_{REF} = 1.5\text{ V}$

Parameter	Symbol	Conditions	Ratings			Unit
			Min	Typ	Max	

**OUTPUT SHORT-CIRCUIT PROTECTION**

EMO Pin Saturation Voltage	Vsatemo	Iemo = 1 mA			400	mV
CEM Pin Charge Current	Icem	Vcem = 0 V	7	10	13	$\mu\text{A}$
CEM Pin Threshold Voltage	Vtcm		0.8	1	1.2	V

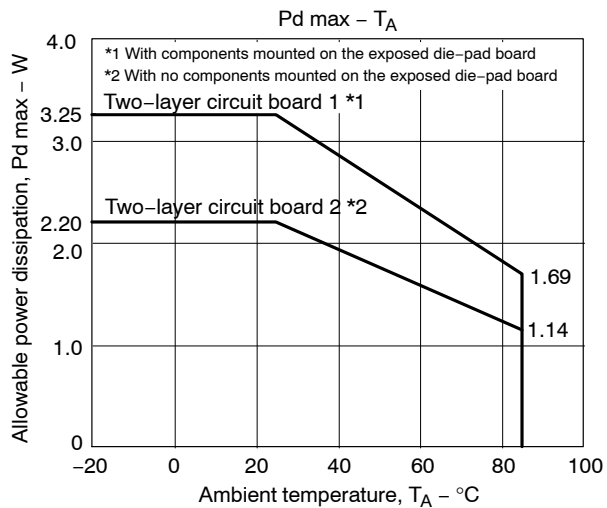

**Figure 1. Power Dissipation vs Ambient Temperature Characteristic**

## LV8731V

### Substrate Specifications (Substrate recommended for operation of LV8731V)

Size: 90 mm × 90 mm × 1.6 mm (two-layer substrate [2S0P])

Material: Glass epoxy

Copper wiring density: L1 = 85% / L2 = 90%

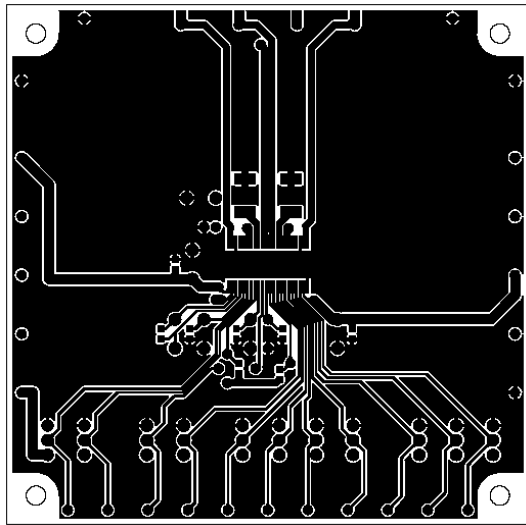

Figure 2. L1: Copper Wiring Pattern Diagram

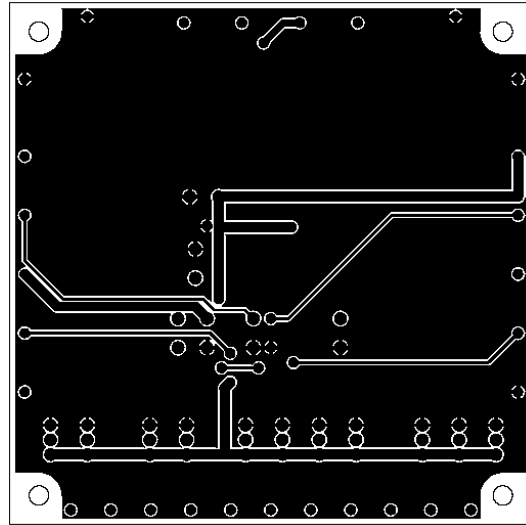

Figure 3. L2: Copper Wiring Pattern Diagram

### Cautions

1. The data for the case with the Exposed Die-Pad substrate mounted shows the values when 90% or more of the Exposed Die-Pad is wet
2. For the set design, employ the derating design with sufficient margin.  
Stresses to be derated include the voltage, current, junction temperature, power loss, and mechanical stresses such as vibration, impact, and tension. Accordingly, the design must ensure these stresses to be as low or small as possible.

The guideline for ordinary derating is shown below :

- (1) Maximum value 80% or less for the voltage rating
- (2) Maximum value 80% or less for the current rating
- (3) Maximum value 80% or less for the temperature rating

3. After the set design, be sure to verify the design with the actual product.  
Confirm the solder joint state and verify also the reliability of solder joint for the Exposed Die-Pad, etc.  
Any void or deterioration, if observed in the solder joint of these parts, causes deteriorated thermal conduction, possibly resulting in thermal destruction of IC

# LV8731V

## PIN ASSIGNMENT

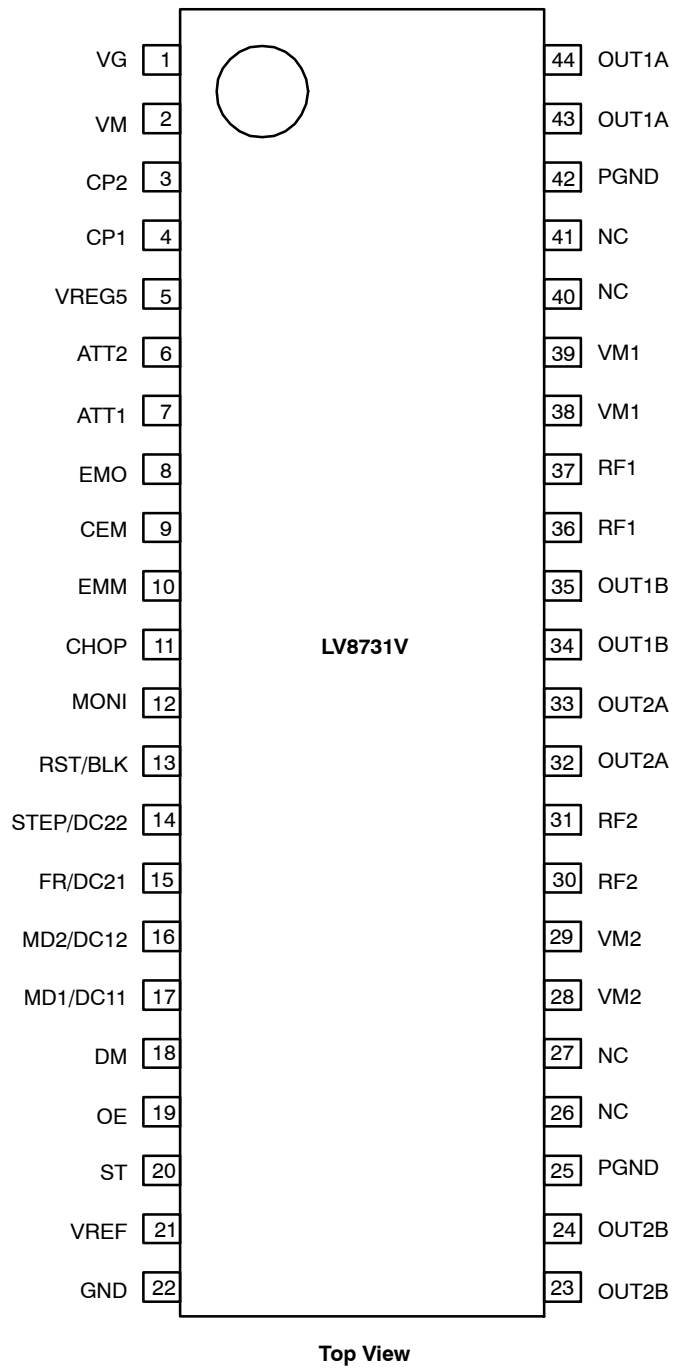

Figure 4. Pin Assignment

# LV8731V

## BLOCK DIAGRAM

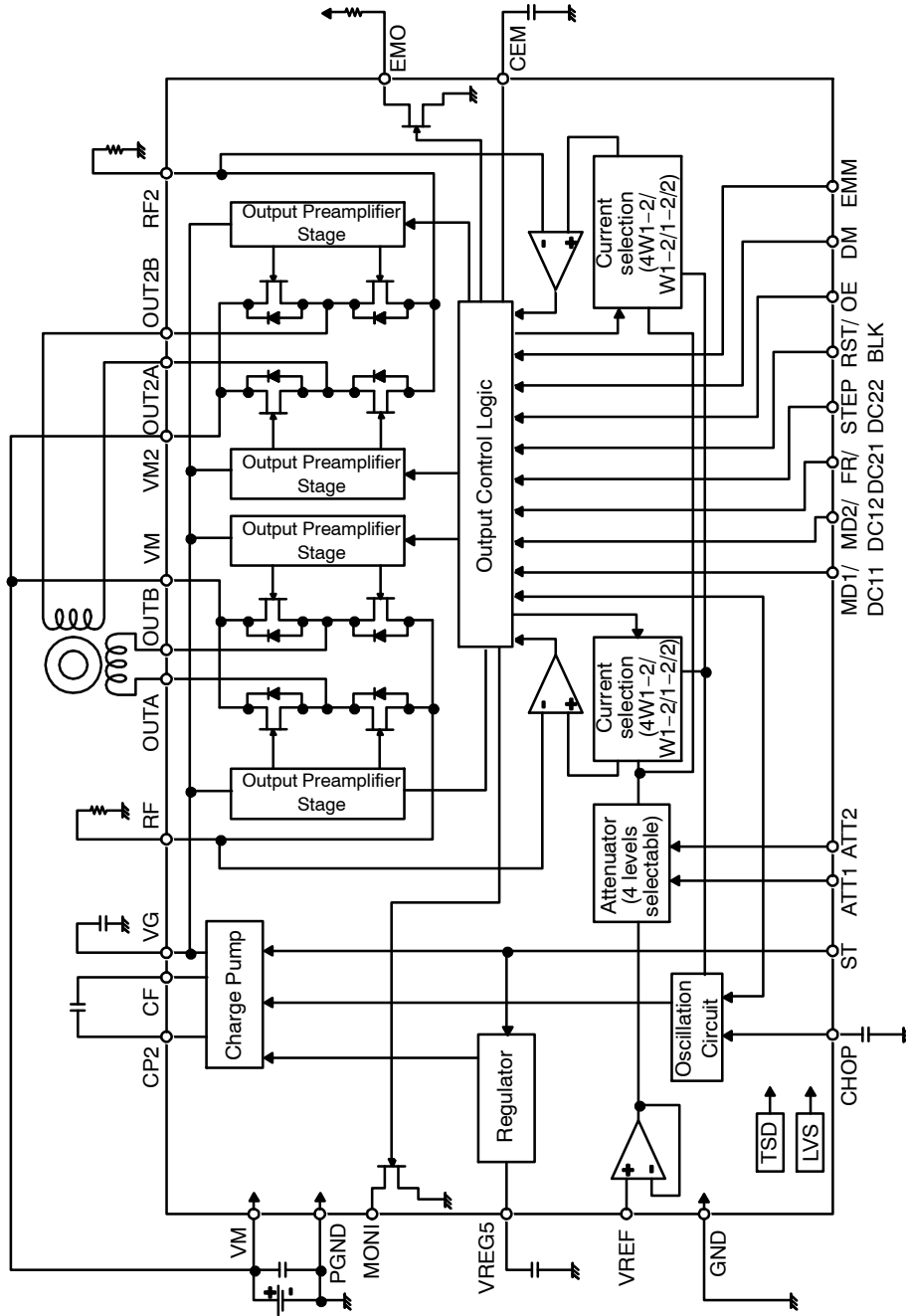

Figure 5. Block Diagram

# LV8731V

## PIN FUNCTIONS

Pin No.	Pin Name	Pin Function	Equivalent Circuit
6 7 10 13 14 15 16 17 18 19	ATT2 ATT1 EMM RST/BLK STEP/DC22 FR/DC21 MD2/DC12 MD1/DC11 DM OE	Motor holding current switching pin Motor holding current switching pin Output short-circuit protection mode switching pin RESET input pin (STM) / Blanking time switching pin (DCM) STEP signal input pin (STM) / Channel 2 output control input pin 2 (DCM) CW / CCW signal input pin (STM) / Channel 2 output control input pin 1 (DCM) Excitation mode switching pin 2 (STM) / Channel 1 output control input pin 2 (DCM) Excitation mode switching pin 1 (STM) / Channel 1 output control input pin 1 (DCM) Drive mode (STM/DCM) switching pin Output enable signal input pin	
20	ST	Chip enable pin	
23, 24 25, 42 28, 29  30, 31 32, 33 34, 35 36, 37 38, 39 43, 44	OUT2B PGND VM2  RF2 OUT2A OUT1B RF1 VM1 OUT1A	Channel 2 OUTB output pin Power system ground Channel 2 motor power supply connection pin  Channel 2 current-sense resistor connection pin Channel 2 OUTA output pin Channel 1 OUTB output pin Channel 1 current-sense resistor connection pin Channel 1 motor power supply pin Channel 1 OUTA output pin	

# LV8731V

## PIN FUNCTIONS (continued)

Pin No.	Pin Name	Pin Function	Equivalent Circuit
1 2 3 4	VG VM CP2 CP1	Charge pump capacitor connection pin Motor power supply connection pin Charge pump capacitor connection pin Charge pump capacitor connection pin	
21	VREF	Constant current control reference voltage input pin	
5	VREG5	Internal power supply capacitor connection pin	
8 12	EMO MONI	Output short-circuit state warning output pin Position detection monitor pin	

# LV8731V

## PIN FUNCTIONS (continued)

Pin No.	Pin Name	Pin Function	Equivalent Circuit
9	CEM	Pin to connect the output short-circuit state detection time setting capacitor	
11	CHOP	Chopping frequency setting capacitor connection pin	
22	GND	Ground	
26, 27 40, 41	NC	No Connection (No internal connection to the IC)	

**Description of Operation**

**Input Pin Function**

*Chip Enable Function*

This IC is switched between standby and operating mode by setting the ST pin. In standby mode, the IC is set to power-save mode and all logic is reset. In addition, the

internal regulator circuit and charge pump circuit do not operate in standby mode.

ST	Mode	Internal Regulator	Charge Pump
Low or Open	Standby mode	Standby	Standby
High	Operating mode	Operating	Operating

*Drive Mode Switching Pin Function*



The IC drive mode is switched by setting the DM pin. In STM mode, stepper motor channel 1 can be controlled by the CLK-IN input. In DCM mode, DC motor channel 2 or

stepper motor channel 1 can be controlled by parallel input. Stepper motor control using parallel input is Full-step or Half-step full torque.

DM	Drive Mode	Application
Low or Open	STM mode	Stepper motor channel 1 (CLK-IN)
High	DCM mode	DC motor channel 2 or stepper motor channel 1 (parallel)

**STM Mode (DM = Low or Open)**

*STEP Pin Function*

Input		Operating mode
ST	STP	
Low	*	Standby mode
High		Excitation step proceeds
High		Excitation step is kept

*Excitation Mode Setting Function*

MD1	MD2	(Excitation mode)	Initial position	
			Channel 1	Channel 2
Low	Low	Full step (2 phase excitation)	100%	-100%
High	Low	Half step (1-2 phase excitation)	100%	0%
Low	High	Quarter step (W1-2 phase excitation)	100%	0%
High	High	1/16 step (4W1-2 phase excitation)	100%	0%

4. This is the initial position of each excitation mode in the initial state after power-on and when the counter is reset.

# LV8731V

## Position Detection Monitoring Function

The MONI position detection monitoring pin is of an open drain type. When the excitation position is in the initial position, the MONI output is placed in the ON state. (Refer to “Examples of Current Waveforms in each Micro-step Mode”)

## Setting Constant-Current Control Reference Current

This IC is designed to automatically exercise PWM constant-current chopping control for the motor current by setting the output current. Based on the voltage input to the VREF pin and the resistance connected between RF and

GND, the output current that is subject to the constant-current control is set using the calculation formula below :

$$I_{OUT} = \left( \frac{V_{REF}}{5} \right) / R_{F \text{ resistance}} \quad (\text{eq. 1})$$

\* The above setting is the output current at 100% of each excitation mode.

The voltage input to the VREF pin can be switched to four-step settings depending on the statuses of the two inputs, ATT1 and ATT2. This is effective for reducing power consumption when motor holding current is supplied.

## ATTENUATION FUNCTION FOR VREF INPUT VOLTAGE

ATT1	ATT2	Current Setting Reference Voltage Attenuation Ratio
Low	Low	100%
High	Low	80%
Low	High	50%
High	High	20%

The formula used to calculate the output current when using the function for attenuating the VREF input voltage is given below.

$$I_{OUT} = \left( \frac{V_{REF}}{5} \right) \times (\text{attenuationratio}) / R_{F \text{ resistance}} \quad (\text{eq. 2})$$

Example: At VREF of 1.5 V, a reference voltage setting of 100% [(ATT1, ATT2) = (L, L)] and an RF resistance of 0.3 Ω, the output current is set as shown below.

$$I_{OUT} = 1.5 \text{ V} / 5 \times 100\% / 0.3 \Omega = 1.0 \text{ A}$$

If, in this state, (ATT1, ATT2) is set to (H, H), IOUT will be as follows :

$$I_{OUT} = 1.0 \text{ A} \times 20\% = 200 \text{ mA}$$

In this way, the output current is attenuated when the motor holding current is supplied so that power can be conserved.

## Input Timing

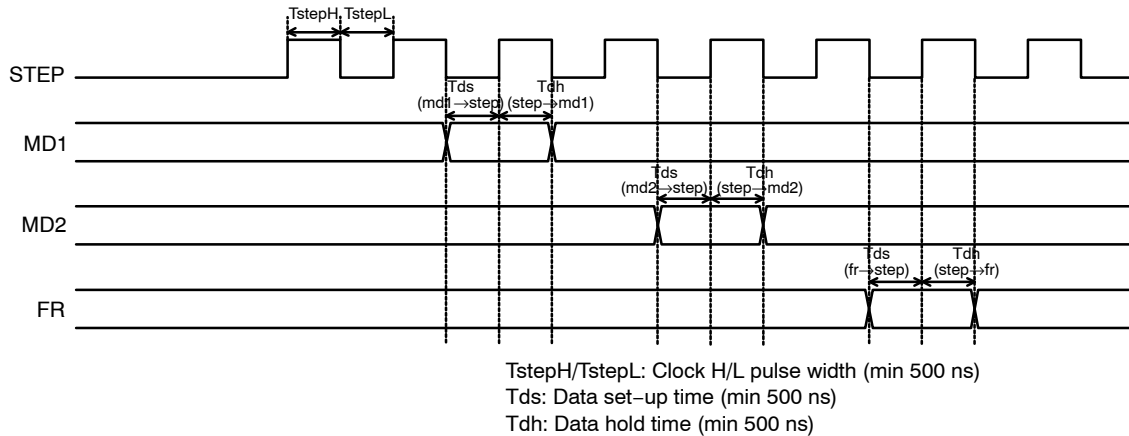

Figure 6. Input Timing

# LV8731V

## Blanking Period

If, when exercising PWM constant-current chopping control over the motor current, the mode is switched from decay to charge, the recovery current of the parasitic diode may flow to the current sensing resistance, causing noise to be carried on the current sensing resistance pin, and this may result in erroneous detection. To prevent this erroneous detection, a blanking period is provided to prevent the noise occurring during mode switching from being received.

During this period, the mode is not switched from charge to decay even if noise is carried on the current sensing resistance pin.

In the stepper motor driver mode (DM = Low or Open) of this IC, the blanking time is fixed at approximately 1 $\mu$ s.

In the DC motor driver mode (DM = High), the blanking time can be switched to one of two levels using the RST/BLK pin. (Refer to “Blanking Time Switching Function.”)

## Reset Function

RST	Operating Mode
Low	Normal operation
High	Reset state

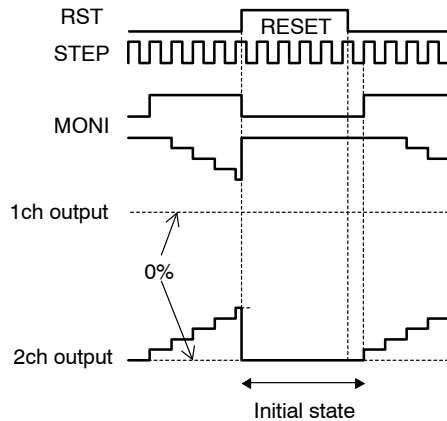

**Figure 7. Reset Function**

When the RST pin is set to High, the excitation position of the output is forcibly set to the initial state, and the MONI output is placed in the ON state. When RST is then set to

Low, the excitation position is advanced by the next STEP input.

## Output Enable Function

OE	Operating Mode
Low	Output ON
High	Output OFF

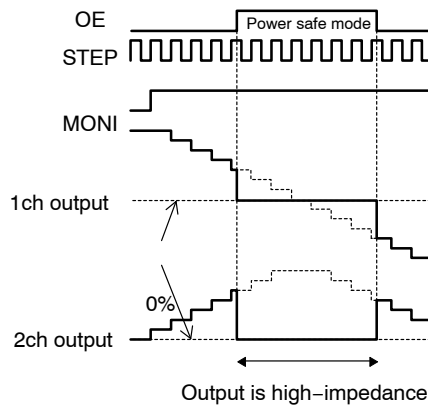

**Figure 8. Output Enable Function**

When the OE pin is set High, the output is forced OFF and goes to high impedance.

However, the internal logic circuits are operating, so the excitation position proceeds when the STEP signal is input. Therefore, when OE is returned to Low, the output level conforms to the excitation position proceeded by the STEP input.

Forward / Reverse Switching Function

FR	Operating Mode
Low	Clockwise (CW)
High	Counter-clockwise (CCW)

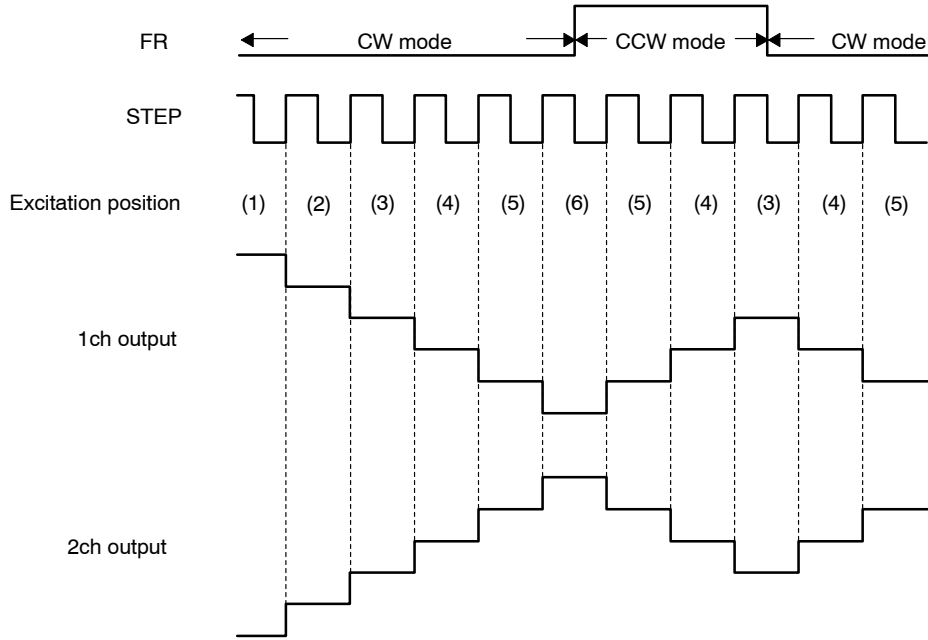

Figure 9. Forward / Reverse Switching Function

The internal D/A converter proceeds by one bit at the rising edge of the input STEP pulse.

In addition, CW and CCW mode are switched by setting the FR pin.

In CW mode, the channel 2 current phase is delayed by 90° relative to the channel 1 current.

In CCW mode, the channel 2 current phase is advanced by 90° relative to the channel 1 current.

Chopping Frequency Setting

For constant-current control, this IC performs chopping operations at the frequency determined by the capacitor (Cchop) connected between the CHOP pin and GND.

The chopping frequency is set as shown below by the capacitor (Cchop) connected between the CHOP pin and GND.

$$F_{chop} = I_{chop} / (C_{chop} \times V_{tchop} \times 2) \text{ (Hz)} \quad (\text{eq. 3})$$

- I<sub>chop</sub>: Capacitor charge / discharge current, typ 10 μA
- V<sub>tchop</sub>: Charge / discharge hysteresis voltage (V<sub>tup</sub>-V<sub>tdown</sub>), typ 0.5 V

For instance, when C<sub>chop</sub> is 200 pF, the chopping frequency will be as follows :

$$F_{chop} = 10 \mu\text{A} / (200 \text{ pF} \times 0.5 \text{ V} \times 2) = 50 \text{ kHz}$$

# LV8731V

Output Current Vector Locus  
(One Step is Normalized to 90 Degrees)

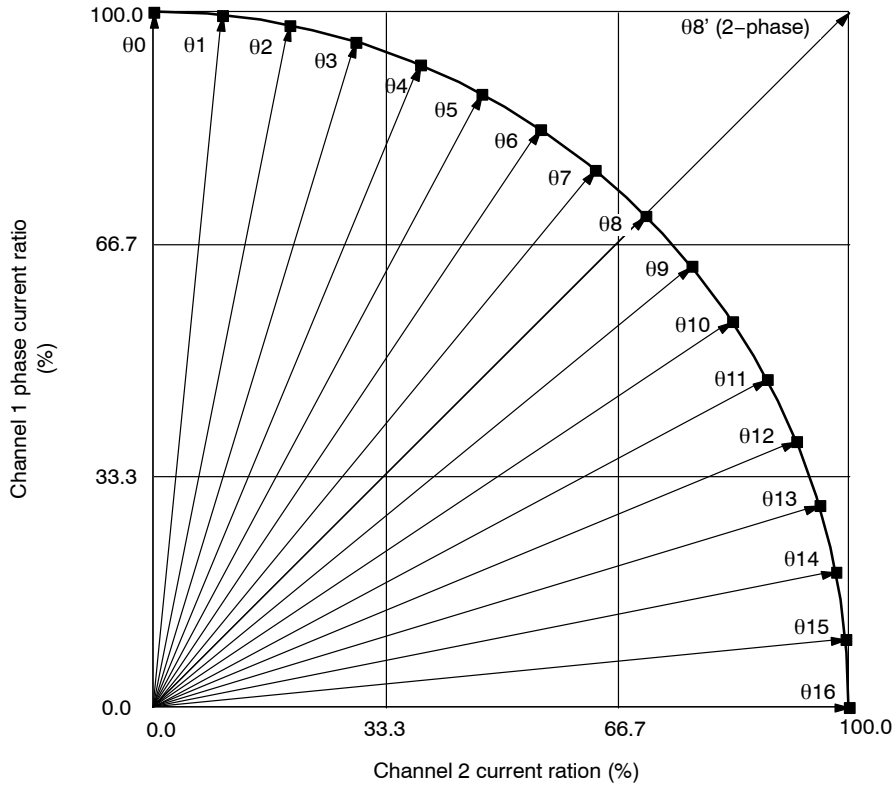

Figure 10. Output Current Vector Locus

## SETTING CURRENT RATION IN EACH MICRO-STEP MODE

STEP	1/16 Step (%)		Quarter Step (%)		Half Step (%)		Full Step (%)	
	Channel 1	Channel 2	Channel 1	Channel 2	Channel 1	Channel 2	Channel 1	Channel 2
00	100	0	100	0	100	0		
01	100	10						
02	98	20						
03	96	29						
04	92	38	92	38				
05	88	47						
06	83	55						
07	77	63						
08	70	70	70	70	70	70	100	100
09	63	77						
010	55	83						
011	47	88						
012	38	92	38	92				
013	29	96						
014	20	98						
015	10	100						
016	0	100	0	100	0	100		

# LV8731V

## Examples of Current Waveforms in each Micro-step Mode

- Full Step (CW Mode)

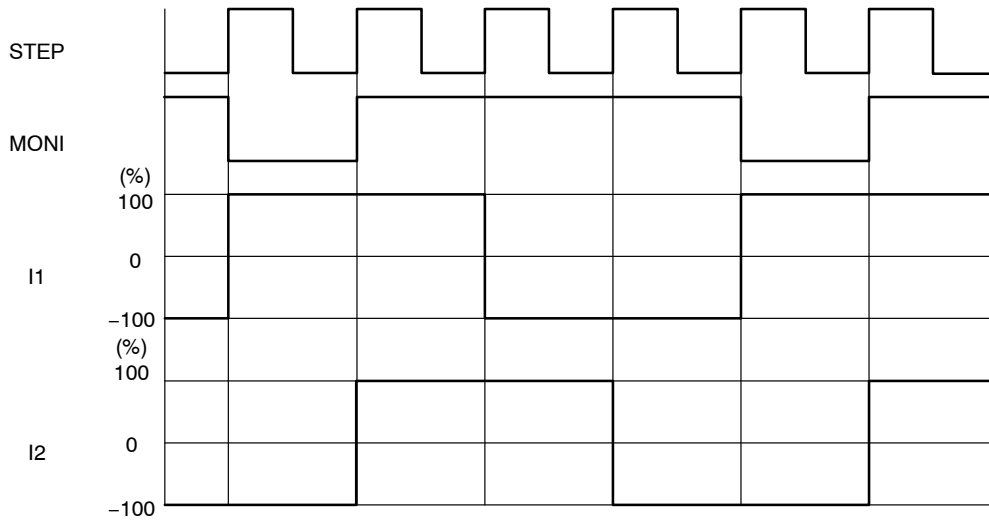

Figure 11. Full Step (CW Mode)

- Half step (CW Mode)

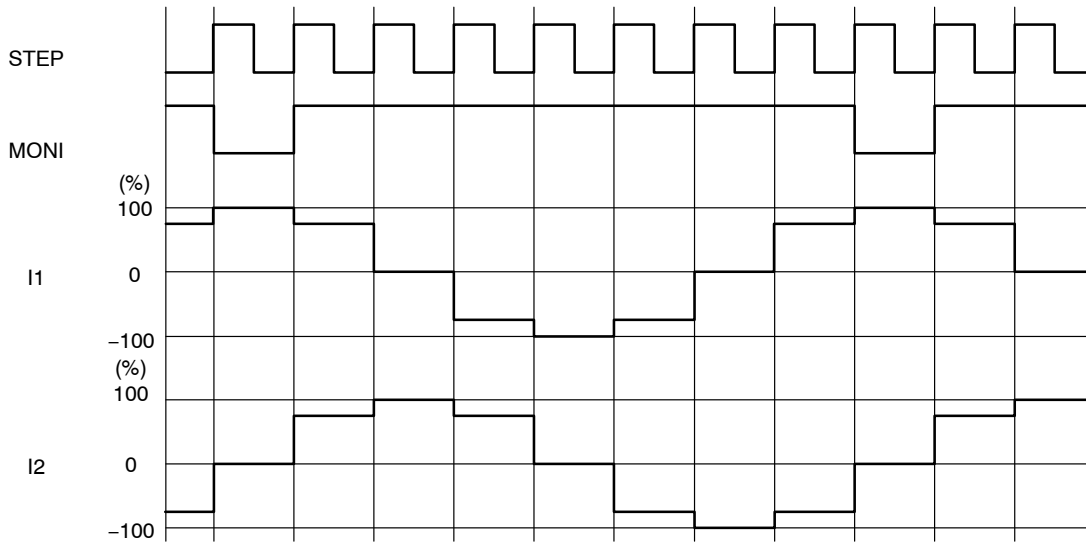

Figure 12. Half Step (CW Mode)

# LV8731V

- Quarter Step (CW Mode)

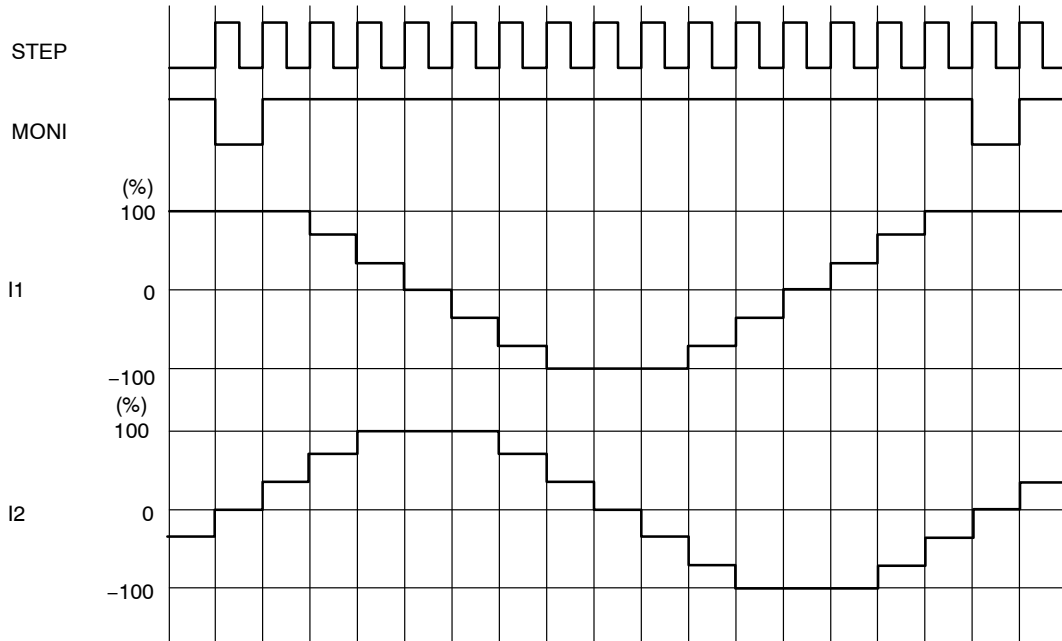

Figure 13. Quarter Step (CW Mode)

- 1/16 Step (CW Mode)

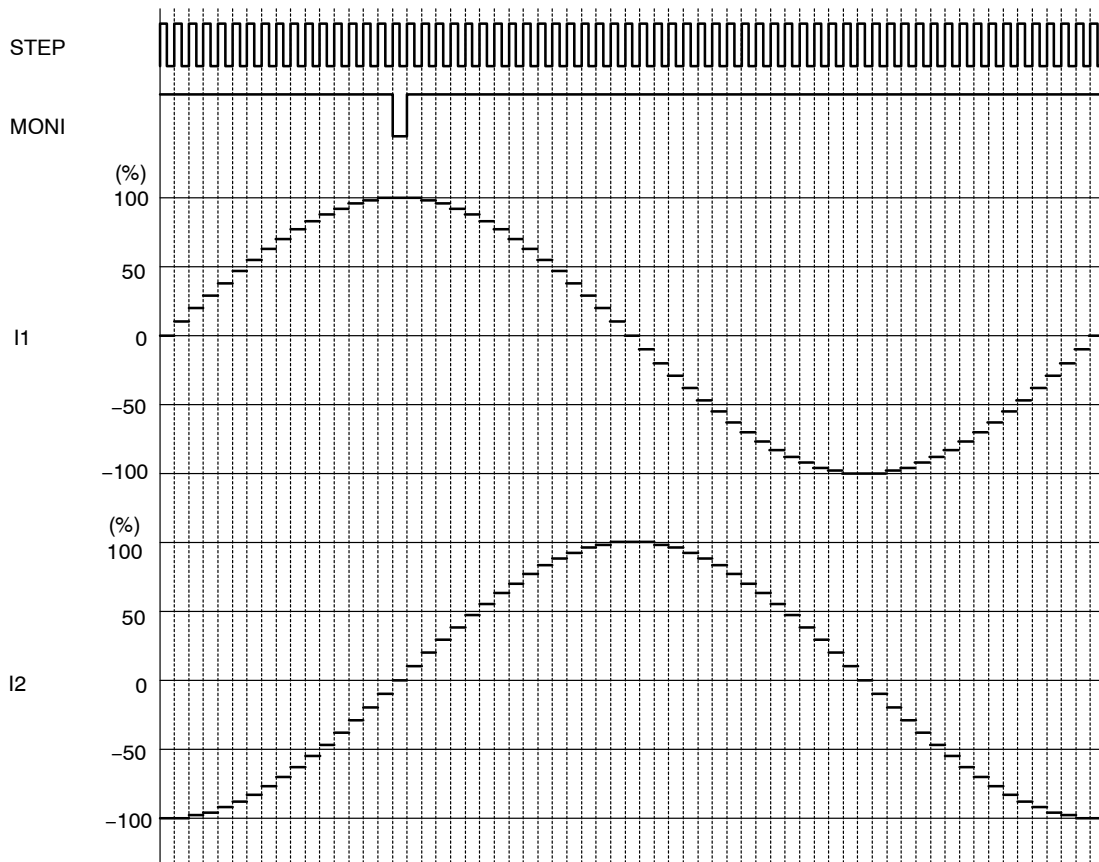

Figure 14. 1/16 Step (CW Mode)

Current Control Operation Specification

• Sine Wave Increasing Direction

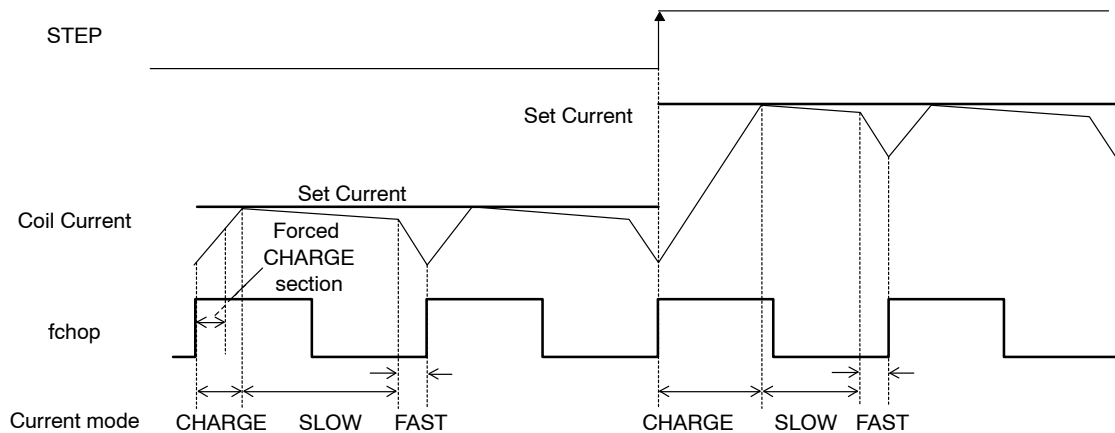

Figure 15. Sine Wave Increasing Direction

• Sine Wave Decreasing Direction

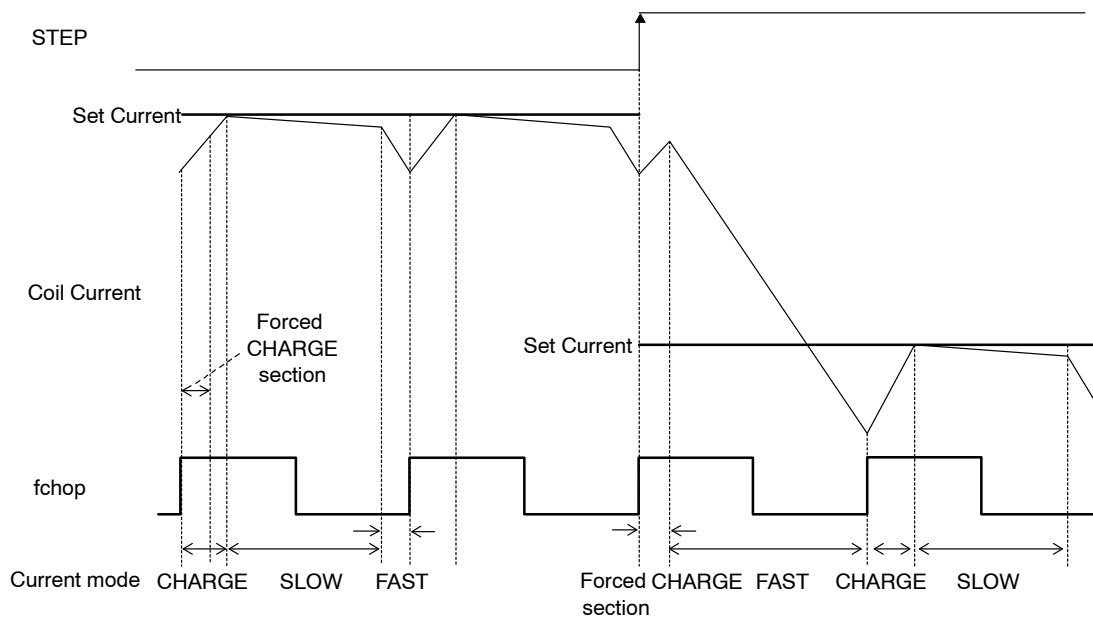

Figure 16. Sine Wave Decreasing Direction

In each current mode, the operation sequence is as described below :

- At rise of chopping frequency, the CHARGE mode begins. (In the time defined as the “blanking time”, the CHARGE mode is forced regardless of the magnitude of the coil current (ICOIL) and set current (IREF))
- The coil current (ICOIL) and set current (IREF) are compared in this blanking time.
  - When  $(ICOIL < IREF)$  state exists ;  
The CHARGE mode up to  $ICOIL \geq IREF$ , then followed by changeover to the SLOW DECAY

mode, and finally by the FAST DECAY mode for approximately  $1 \mu s$

- When  $(ICOIL < IREF)$  state does not exist ;  
The FAST DECAY mode begins. The coil current is attenuated in the FAST DECAY mode till one cycle of chopping is over

Above operations are repeated. Normally, the SLOW (+FAST) DECAY mode continues in the sine wave increasing direction, then entering the FAST DECAY mode till the current is attenuated to the set level and followed by the SLOW DECAY mode.

## LV8731V

### DCM Mode (DM = High)

#### DCM Mode Output Control Logic

Parallel Input		Output		Mode
DC11 (21)	DC12 (22)	OUT1 (2) A	OUT1 (2) B	
Low	Low	OFF	OFF	Standby
High	Low	High	Low	CW (Forward)
Low	High	Low	High	CCW (Reverse)
High	High	Low	Low	Brake

#### Blanking Time Switching Function

BLK	Blanking Time
Low	2 $\mu$ s
High	3 $\mu$ s

#### Output Enable Function

OE	Operating Mode
Low	Output ON
High	Output OFF

When the OE pin is set High, the output is forced OFF and goes to high impedance. When the OE pin is set Low, output conforms to the control logic.

*Current Limit Reference Voltage Setting Function*

By setting a current limit, this IC automatically exercises short braking control to ensure that when the motor current has reached this limit, the current will not exceed it.

- Current Limit Control Time Chart

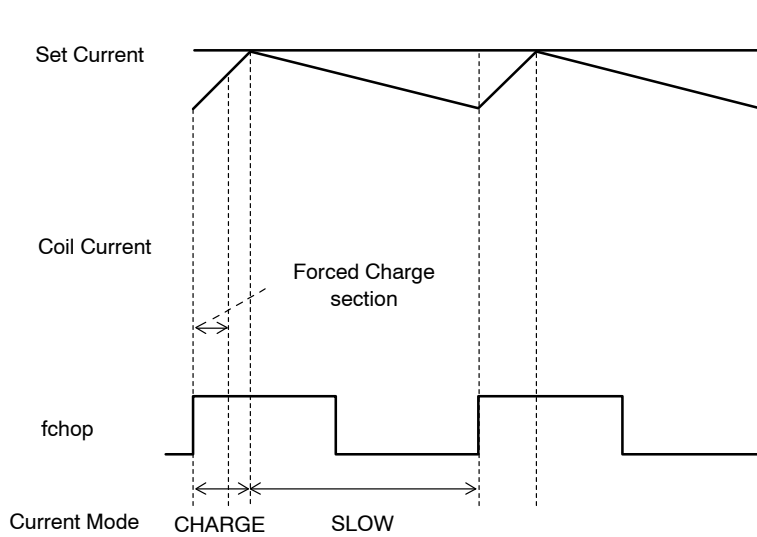

**Figure 17. Current Limit Control Time Chart**

The limit current is set as calculated on the basis of the voltage input to the VREF pin and the resistance between the RF pin and GND using the formula given below.

$$I_{limit} = (V_{REF} / 5) / R_F \text{ resistance} \quad (\text{eq. 4})$$

The voltage applied to the VREF pin can be switched to any of the four setting levels depending on the statuses of the two inputs, ATT1 and ATT2.

- Function for Attenuating VREF Input Voltage

ATT1	ATT2	Current Setting Reference Voltage Attenuation Ratio
Low	Low	100%
High	Low	80%
Low	High	50%
High	High	20%

The formula used to calculate the output current when using the function for attenuating the VREF input voltage is given below.

$$I_{limit} = (V_{REF} / 5) \times (\text{attenuation ratio}) / R_F \text{ resistance} \quad (\text{eq. 5})$$

Example: At VREF of 1.5 V, a reference voltage setting of 100% [(ATT1, ATT2) = (L, L)] and an RF resistance of 0.3 Ω, the output current is set as shown below.

$$I_{limit} = 1.5 \text{ V} / 5 \times 100\% / 0.3 \Omega = 1.0 \text{ A}$$

If, in this state, (ATT1, ATT2) has been set to (H, H), I<sub>limit</sub> will be as follows :

$$I_{limit} = 1.0 \text{ A} \times 20\% = 200 \text{ mA}$$

# LV8731V

Examples of Current Waveform in each Micro-step Mode when Stepper Motor Parallel Input Control

- Full Step (CW Mode)

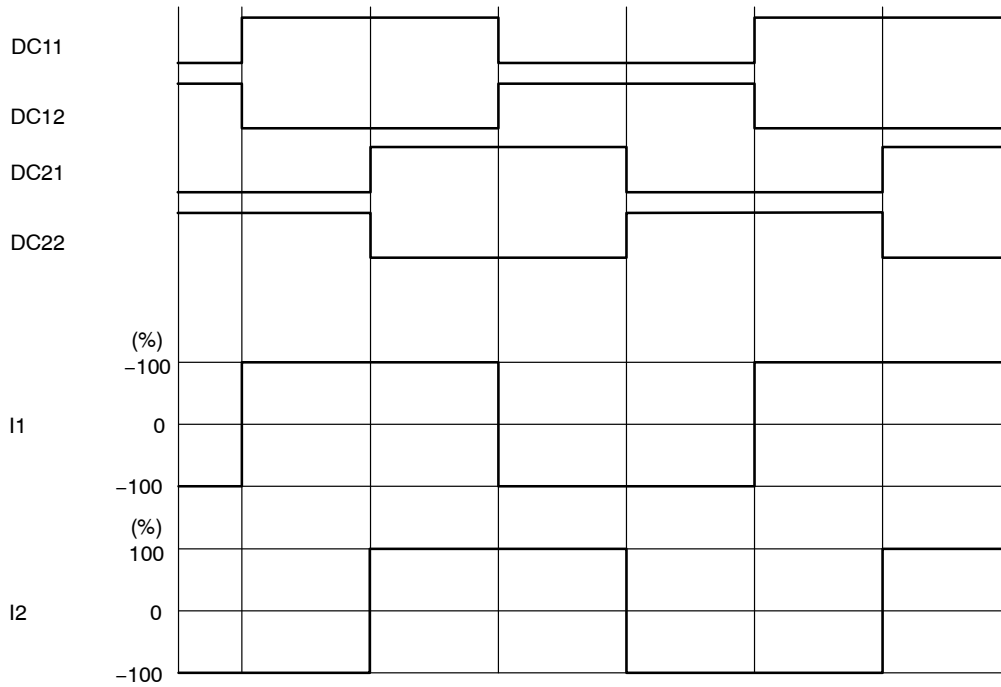

- Half Step Full Torque (CW Mode)

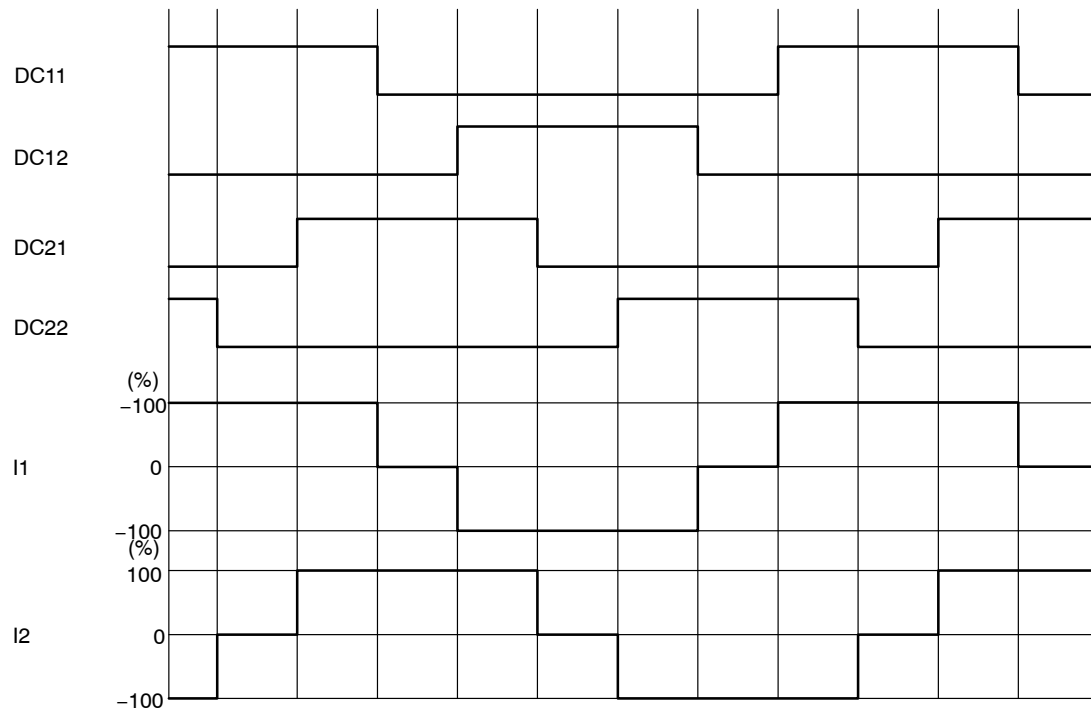

**Output Short-circuit Protection Function**

This IC incorporates an output short-circuit protection circuit that, when the output has been shorted by an event such as shorting to power or shorting to ground, sets the output to the standby mode and turns on the warning output in order to prevent the IC from being damaged. In the stepping motor driver (STM) mode (DM = Low), this function sets the output to the standby mode for both channels by detecting the short-circuiting in one of the channels. In the DC motor driver mode (DM = High), channels 1 and 2 operate independently. (Even if the output of channel 1 has been short-circuited, channel 2 will operate normally.)

*Output Short-circuit Protection Mode Switching Function*

Output short-circuit protection mode of IC can be switched by the setting of EMM pin.

EMM	State
Low or Open	Latch method
High	Auto reset method

*Latch Type*

In the latch mode, when the output current exceeds the detection current level, the output is turned OFF, and this state is held.

The detection of the output short-circuited state by the IC causes the output short-circuit protection circuit to be activated.

When the short-circuited state continues for the period of time set using the internal timer (approximately 2μs), the output in which the short-circuiting has been detected is first set to OFF. After this, the output is set to ON again as soon as the timer latch time (Tcem) described later has been exceeded, and if the short-circuited state is still detected, all the outputs of the channel concerned are switched to the standby mode, and this state is held.

This state is released by setting ST to low.

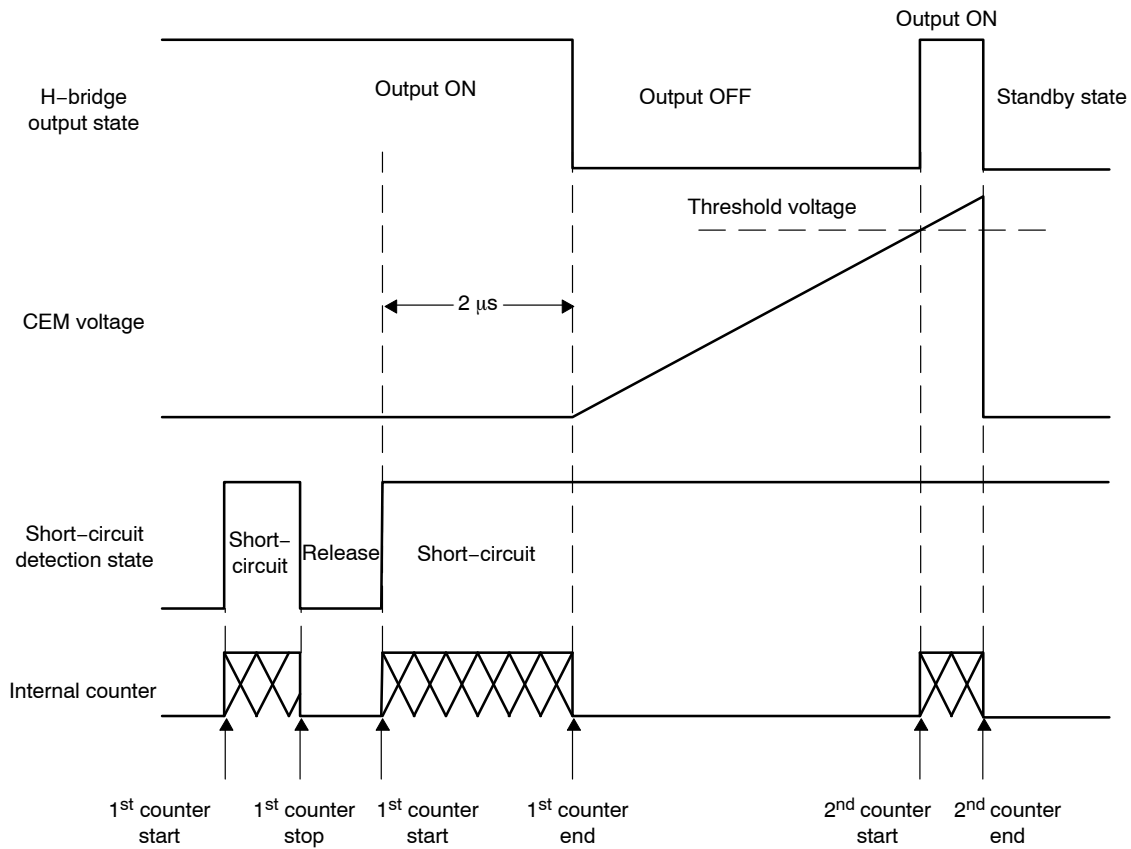

**Figure 18. Latch Type**

## LV8731V

### *Auto Reset Type*

In the automatic reset mode, when the output current exceeds the detection current level, the output waveform changes to the switching waveform.

As with the latch system, when the output short-circuited state is detected, the short-circuit protection circuit is activated. When the operation of the short-circuit detection circuit exceeds the timer latch time ( $T_{cem}$ ) described later, the output is changed over to the standby mode and is reset to the ON mode again in 2 ms (typ). In this event, if the over current mode still continues, the switching mode described above is repeated until the over current mode is canceled.

### *Unusual Condition Warning Output Pins (EMO, MONI)*

The LV8731V is provided with the EMO pin which notifies the CPU of an unusual condition if the protection circuit operates by detecting an unusual condition of the IC. This pin is of the open-drain output type and when an unusual condition is detected, the EMO output is placed in the ON (EMO = Low) state.

In the DC motor driver mode (DM = High), the MONI pin also functions as a warning output pin.

The functions of the EMO pin and MONI pin change as shown below depending on the state of the DM pin.

When the DM is low (STM mode) :

- EMO: Unusual condition warning output pin
- MONI: Excitation initial position detection monitoring

When the DM is high (DCM mode) :

- EMO: Channel 1 warning output pin
- MONI: Channel 2 warning output pin

Furthermore, the EMO (MONI) pin is placed in the ON state when one of the following conditions occurs.

1. Shorting-to-power, shorting-to-ground, or shorting-to-load occurs at the output pin and the output short-circuit protection circuit is activated
2. The IC junction temperature rises and the thermal protection circuit is activated

Unusual Condition	DM = L (STM Mode)		DM = H (DCM Mode)	
	EMO	MONI	EMO	MONI
Channel 1 Short-circuit Detected	ON	-	ON	-
Channel 2 Short-circuit Detected	ON	-	-	ON
Overheating Condition Detected	ON	-	ON	ON

### *Timer Latch Time ( $T_{cem}$ )*

The time taken for the output to be set to OFF when the output has been short-circuited can be set using capacitor  $C_{cem}$ , connected between the CEM pin and GND. The value of capacitor  $C_{cem}$  is determined by the formula given below.

Timer latch :  $T_{cem}$

$$T_{cem} \approx C_{cem} \times V_{t_{cem}} / I_{cem} \text{ [sec]}$$

$V_{t_{cem}}$ : Comparator threshold voltage, typ 1 V

$I_{cem}$ : CEM pin charge current, typ 10  $\mu$ A

**Thermal Shutdown Function**

The thermal shutdown circuit is included, and the output is turned off when junction temperature  $T_J$  exceeds  $180^\circ\text{C}$  and the abnormal state warning output is turned on at the same time.

When the temperature falls hysteresis level, output is driven again (automatic restoration)

The thermal shutdown circuit doesn't guarantee protection of the set and the destruction prevention of IC, because it works at the temperature that is higher than rating ( $T_{Jmax} = 150^\circ\text{C}$ ) of the junction temperature:

TTSD =  $180^\circ\text{C}$  (typ)

$\Delta\text{TSD} = 40^\circ\text{C}$  (typ)

**Charge Pump Circuit**

When the ST pin is set High, the charge pump circuit operates and the VG pin voltage is boosted from the VM voltage to the  $\text{VM} + \text{VREG5}$  voltage.

If the VG pin voltage is not boosted to  $\text{VM} + 4\text{ V}$  or more, the output pin cannot be turned on. Therefore it is recommended that the drive of motor is started after the time has passed tONG or more.

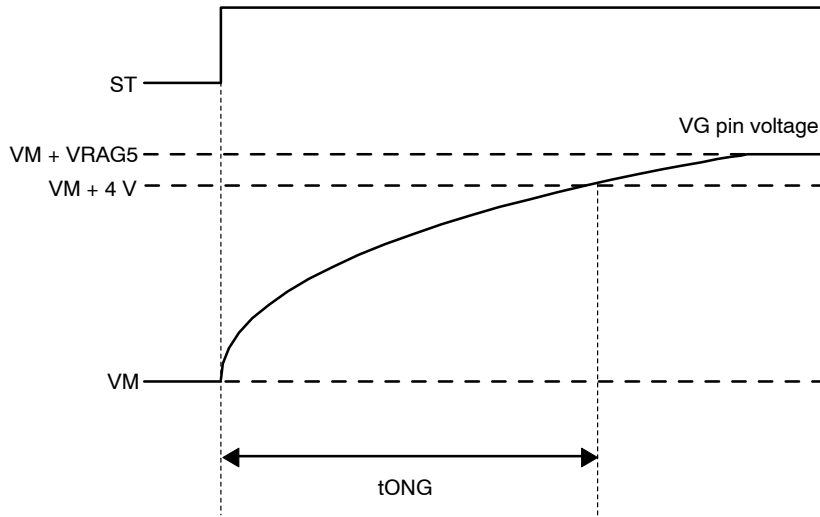

Figure 19. VG Pin Voltage Schematic View

# LV8731V

## APPLICATION CIRCUIT EXAMPLE

- Stepper Motor Driver Circuit (DM = Low)

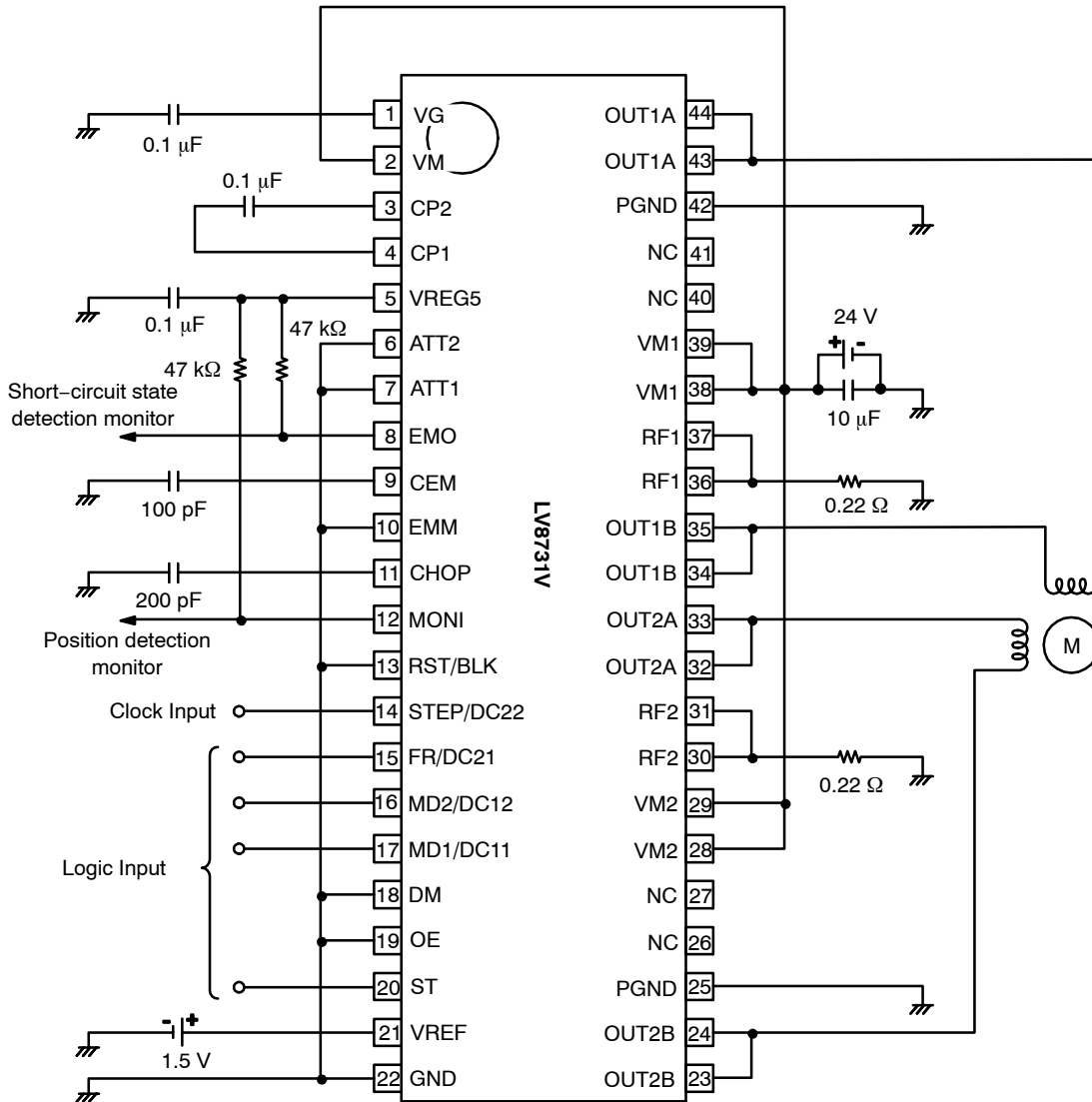

Figure 20.

The formulae for setting the constants in the examples of the application circuits above are as follows :

Constant current (100%) setting

When VREF = 1.5 V

$$I_{OUT} = VREF / 5 / RF \text{ resistance}$$

$$= 1.5 \text{ V} / 5 / 0.22 \Omega = 1.36 \text{ A}$$

Chopping frequency setting

$$F_{chop} = I_{chop} / (C_{chop} \times V_{tchop} \times 2)$$

$$= 10 \mu\text{A} / (200\text{pF} \times 0.5 \text{ V} \times 2) = 50 \text{ kHz}$$

Timer latch time when the output is short-circuited

$$T_{cem} = C_{cem} \times V_{tcem} / I_{cem}$$

$$= 100 \text{ pF} \times 1 \text{ V} / 10 \mu\text{A} = 10 \mu\text{s}$$

# LV8731V

- DC Motor Driver Circuit  
(DM = High, and the current limit function is in use)

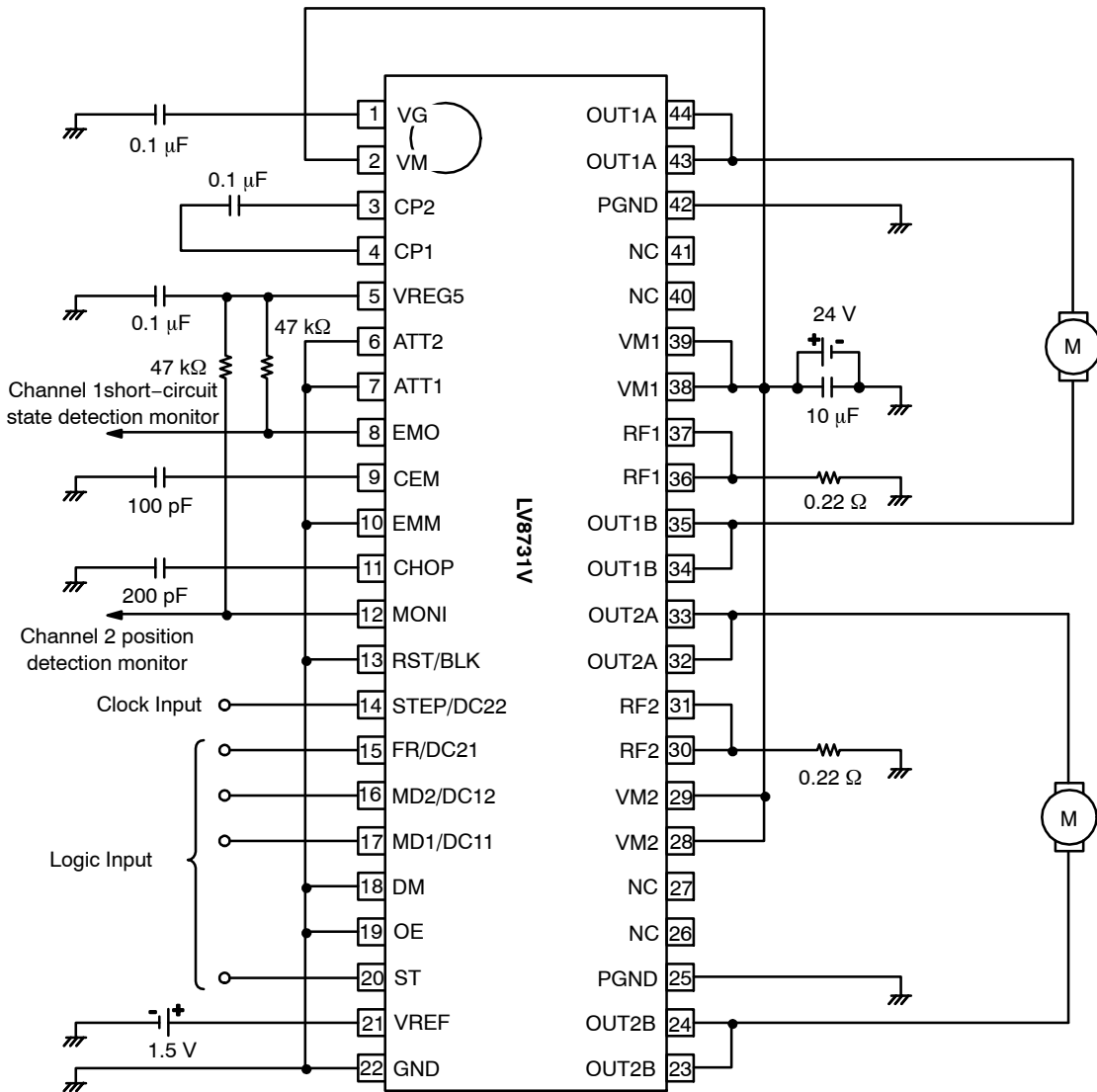

Figure 21.

The formulae for setting the constants in the examples of the application circuits above are as follows :

Constant current limit (100%) setting

When VREF = 1.5 V

$$I_{limit} = VREF / 5 / RF \text{ resistance}$$

$$= 1.5 \text{ V} / 5 / 0.22 \Omega = 1.36 \text{ A}$$

Chopping frequency setting

$$F_{chop} = I_{chop} / (C_{chop} \times V_{tchop} \times 2)$$

$$= 10 \mu\text{A} / (200 \text{ pF} \times 0.5 \text{ V} \times 2) = 50 \text{ kHz}$$

Timer latch time when the output is short-circuited

$$T_{cem} = C_{cem} \times V_{tcem} / I_{cem}$$

$$= 100 \text{ pF} \times 1 \text{ V} / 10 \mu\text{A} = 10 \mu\text{s}$$

## ORDERING INFORMATION

Device	Package	Shipping†
LV8731V-TLM-H	SSOP44K (275 mil) (Pb-Free / Halogen Free)	2000 / Tape & Reel

†For information on tape and reel specifications, including part orientation and tape sizes, please refer to our Tape and Reel Packaging Specifications Brochure, BRD8011/D.

**MECHANICAL CASE OUTLINE**  
**PACKAGE DIMENSIONS**

**SSOP44K (275mil) Exposed Pad**  
**CASE 940AF**  
**ISSUE A**

DATE 08 NOV 2013

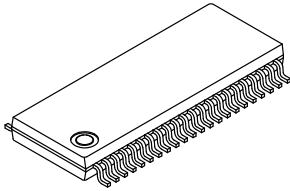

TOP VIEW

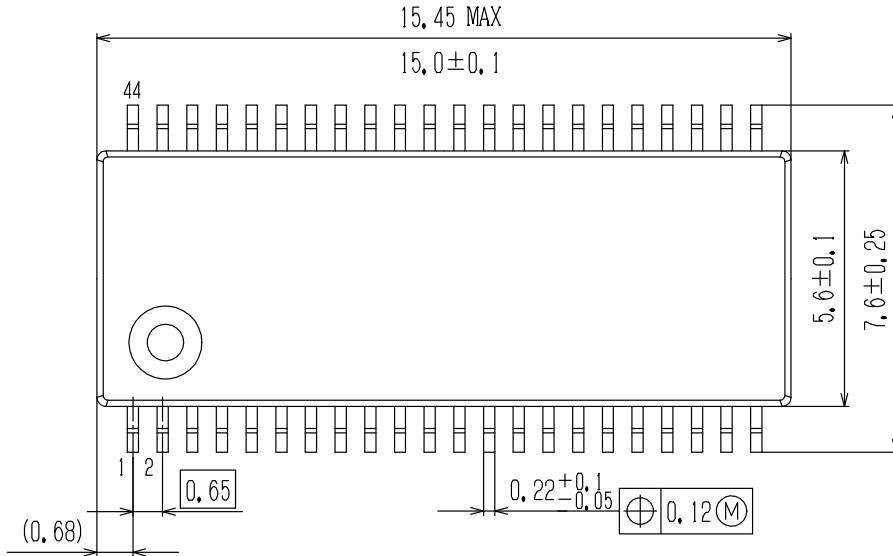

SIDE VIEW

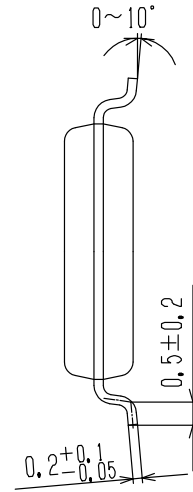

SIDE VIEW

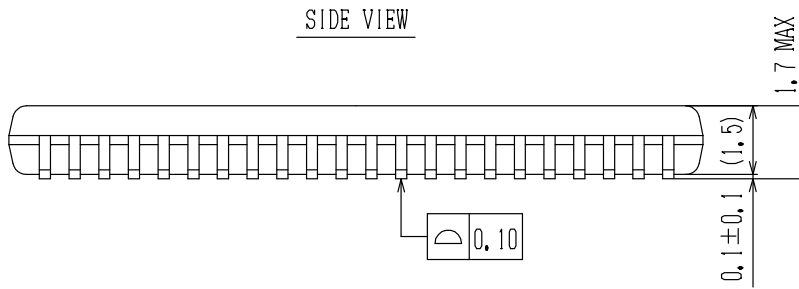

BOTTOM VIEW

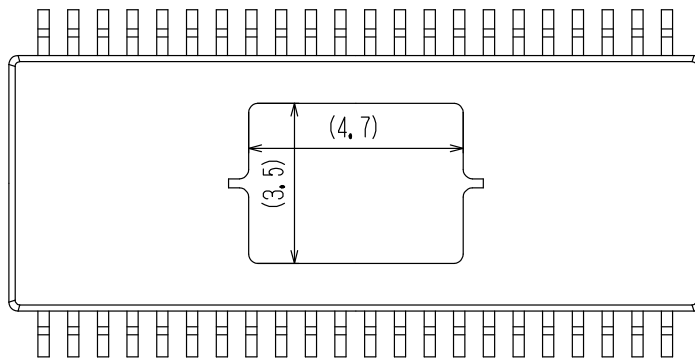

<b>DOCUMENT NUMBER:</b>	<b>98AON66077E</b>	Electronic versions are uncontrolled except when accessed directly from the Document Repository. Printed versions are uncontrolled except when stamped "CONTROLLED COPY" in red.
<b>STATUS:</b>	<b>ON SEMICONDUCTOR STANDARD</b>	
<b>NEW STANDARD:</b>		
<b>DESCRIPTION:</b>	<b>SSOP44K (275MIL) EXPOSED PAD</b>	<b>PAGE 1 OF 3</b>

**SOLDERING FOOTPRINT\***

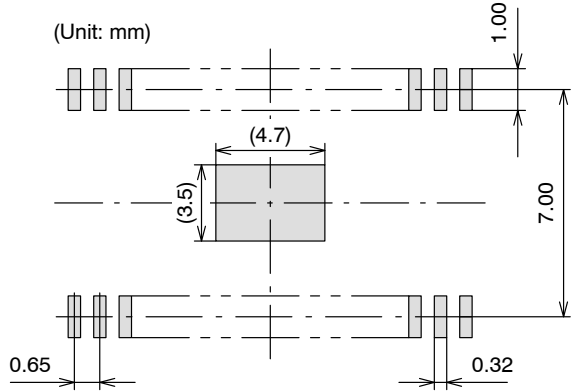

**NOTES:**

1. The measurements are for reference only, and unable to guarantee.
2. Please take appropriate action to design the actual Exposed Die Pad and Fin portion.
3. After setting, verification on the product must be done.  
 (Although there are no recommended design for Exposed Die Pad and Fin portion Metal mask and shape for Through-Hole pitch (Pitch & Via etc), checking the soldered joint condition and reliability verification of soldered joint will be needed. Void ▀ gradient ▀ insufficient thickness of soldered joint or bond degradation could lead IC destruction because thermal conduction to substrate becomes poor.)

\*For additional information on our Pb-Free strategy and soldering details, please download the ON Semiconductor Soldering and Mounting Techniques Reference Manual, SOLDERRM/D.

**GENERIC MARKING DIAGRAM\***

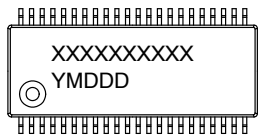

XXXXX = Specific Device Code  
 Y = Year  
 M = Month  
 DDD = Additional Traceability Data

\*This information is generic. Please refer to device data sheet for actual part marking.  
 Pb-Free indicator, "G" or microdot "▪", may or may not be present.

<b>DOCUMENT NUMBER:</b>	<b>98AON66077E</b>	Electronic versions are uncontrolled except when accessed directly from the Document Repository. Printed versions are uncontrolled except when stamped "CONTROLLED COPY" in red.
<b>STATUS:</b>	<b>ON SEMICONDUCTOR STANDARD</b>	
<b>NEW STANDARD:</b>		
<b>DESCRIPTION:</b>	<b>SSOP44K (275MIL) EXPOSED PAD</b>	<b>PAGE 2 OF 3</b>



ON Semiconductor and  are trademarks of Semiconductor Components Industries, LLC dba ON Semiconductor or its subsidiaries in the United States and/or other countries. ON Semiconductor owns the rights to a number of patents, trademarks, copyrights, trade secrets, and other intellectual property. A listing of ON Semiconductor's product/patent coverage may be accessed at [www.onsemi.com/site/pdf/Patent-Marking.pdf](http://www.onsemi.com/site/pdf/Patent-Marking.pdf). ON Semiconductor reserves the right to make changes without further notice to any products herein. ON Semiconductor makes no warranty, representation or guarantee regarding the suitability of its products for any particular purpose, nor does ON Semiconductor assume any liability arising out of the application or use of any product or circuit, and specifically disclaims any and all liability, including without limitation special, consequential or incidental damages. Buyer is responsible for its products and applications using ON Semiconductor products, including compliance with all laws, regulations and safety requirements or standards, regardless of any support or applications information provided by ON Semiconductor. "Typical" parameters which may be provided in ON Semiconductor data sheets and/or specifications can and do vary in different applications and actual performance may vary over time. All operating parameters, including "Typicals" must be validated for each customer application by customer's technical experts. ON Semiconductor does not convey any license under its patent rights nor the rights of others. ON Semiconductor products are not designed, intended, or authorized for use as a critical component in life support systems or any FDA Class 3 medical devices or medical devices with a same or similar classification in a foreign jurisdiction or any devices intended for implantation in the human body. Should Buyer purchase or use ON Semiconductor products for any such unintended or unauthorized application, Buyer shall indemnify and hold ON Semiconductor and its officers, employees, subsidiaries, affiliates, and distributors harmless against all claims, costs, damages, and expenses, and reasonable attorney fees arising out of, directly or indirectly, any claim of personal injury or death associated with such unintended or unauthorized use, even if such claim alleges that ON Semiconductor was negligent regarding the design or manufacture of the part. ON Semiconductor is an Equal Opportunity/Affirmative Action Employer. This literature is subject to all applicable copyright laws and is not for resale in any manner.

## PUBLICATION ORDERING INFORMATION

### LITERATURE FULFILLMENT:

Literature Distribution Center for ON Semiconductor  
19521 E. 32nd Pkwy, Aurora, Colorado 80011 USA  
**Phone:** 303-675-2175 or 800-344-3860 Toll Free USA/Canada  
**Fax:** 303-675-2176 or 800-344-3867 Toll Free USA/Canada  
**Email:** [orderlit@onsemi.com](mailto:orderlit@onsemi.com)

**N. American Technical Support:** 800-282-9855 Toll Free  
USA/Canada  
**Europe, Middle East and Africa Technical Support:**  
Phone: 421 33 790 2910

**ON Semiconductor Website:** [www.onsemi.com](http://www.onsemi.com)

**Order Literature:** <http://www.onsemi.com/orderlit>

For additional information, please contact your local  
Sales Representative

## Looking for pricing, stock, or lifecycle information?

Click below to explore more details on WIN SOURCE:

 [View LV8731V-TLM-H on WIN SOURCE](#)

 [ON Semiconductor](#) Information

## Optimize Your Supply Chain with WIN SOURCE Solutions

-  Global Sourcing Solution
-  Obsolete Management
-  Cost Control Management
-  Shortage Management
-  Alternative Solution
-  Excess Inventory Management