



ON Semiconductor®

<http://onsemi.com>

LV8406T

Bi-CMOS IC 2ch Forward/Reverse Motor Driver

Overview

LV8406T is a 2-channel forward/reverse motor driver IC using D-MOS FET for output stage. As MOS circuit is used, it supports the PWM input. Its features are that the on resistance (0.75Ω typ) and current dissipation are low. It also provides protection functions such as heat protection circuit and reduced voltage detection and is optimal for the motors that need high-current.

Functions

- 2-channel forward/reverse motor driver.
- Low power consumption.
- Low-ON resistance 0.75Ω .
- Built-in low voltage reset and thermal shutdown circuit.
- Four mode function forward/reverse, brake, stop.
- Built-in charge pump.

Specifications

Absolute Maximum Ratings at $T_a = 25^\circ\text{C}$, $\text{SGND} = \text{PGND} = 0\text{V}$

Parameter	Symbol	Conditions	Ratings	Unit
Power supply voltage (for load)	VM max	VM1, VM2	-0.5 to 16.0	V
Power supply voltage (for control)	V _{CC} max		-0.5 to 6.0	V
Output current	I _O max		1.4	A
Output peak current	I _O peak	$t \leq 10\text{ms}$	2.5	A
Input voltage	V _{IN} max		-0.5 to V _{CC} +0.5	V
Allowable power dissipation	Pd max	Mounted on a specified board*	3.1	W
Operating temperature	T _{opr}		-30 to +85	°C
Storage temperature	T _{stg}		-55 to +150	°C

* Specified board : 90mm × 90mm × 1.6mm, glass epoxy 2-layer board (2SOP).

Caution 1) Absolute maximum ratings represent the value which cannot be exceeded for any length of time.

Caution 2) Even when the device is used within the range of absolute maximum ratings, as a result of continuous usage under high temperature, high current, high voltage, or drastic temperature change, the reliability of the IC may be degraded. Please contact us for the further details.

Stresses exceeding Maximum Ratings may damage the device. Maximum Ratings are stress ratings only. Functional operation above the Recommended Operating Conditions is not implied. Extended exposure to stresses above the Recommended Operating Conditions may affect device reliability.

LV8406T

Allowable Operating Conditions at $T_a = 25^\circ\text{C}$, $\text{SGND} = \text{PGND} = 0\text{V}$

Parameter	Symbol	Conditions	Ratings	Unit
Power supply voltage (VM pin)	VM		1.5 to 15.0	V
Power supply voltage (V_{CC} pin)	V_{CC}		2.8 to 5.5	V
Input signal voltage	V_{IN}		0 to V_{CC}	V
Input signal frequency	f max		200	kHz

Electrical Characteristics $T_a = 25^\circ\text{C}$, $V_{\text{CC}} = 3.0\text{V}$, $\text{VM} = \text{VS} = 6.0\text{V}$, $\text{SGND} = \text{PGND} = 0\text{V}$, unless otherwise specified.

Parameter	Symbol	Conditions	Remarks	Ratings			Unit
				min	typ	max	
Standby load current drain	IMO	$\text{EN} = 0\text{V}$	1			1.0	μA
Standby control current drain	ICO	$\text{EN} = \text{IN1} = \text{IN2} = \text{IN3} = \text{IN4} = 0\text{V}$	2			1.0	μA
Standby load current drain2	IMO2	$V_{\text{CC}} = 0\text{V}$, $\text{VM} = \text{VS} = 6\text{V}$				1.0	μA
Operating control current drain	IC1	$\text{EN} = 3\text{V}$, with no load	3		0.85	1.2	mA
High-level input voltage	V_{IH}	$2.7 \leq V_{\text{CC}} \leq 5.5\text{V}$		$0.6 \times V_{\text{CC}}$		V_{CC}	V
Low-level input voltage	V_{IL}	$2.7 \leq V_{\text{CC}} \leq 5.5\text{V}$		0		$0.2 \times V_{\text{CC}}$	V
High-level input current (EN1, EN2, IN1, IN2, IN3, IN4)	I_{IH1}	$V_{\text{IN}} = 3\text{V}$	4		15	25	μA
Low-level input current (EN1, EN2, IN1, IN2, IN3, IN4)	I_{IL1}	$V_{\text{IN}} = 0\text{V}$	4	-1.0			μA
Pull-down resistance value	RDN	EN1, EN2, IN1, IN2, IN3, IN4		100	200	400	k Ω
Charge pump voltage	VG	$V_{\text{CC}} + \text{VS}$		8.5	9.0	9.5	V
Output ON resistance 1	RON1	Sum of top and bottom sides ON resistance.	5		0.75	1.2	Ω
Output ON resistance 2	RON2	Sum of top and bottom sides ON resistance. $V_{\text{CC}} = 2.8\text{V}$	5		1.0	1.5	Ω
Low-voltage detection voltage	VCS	V_{CC} pin voltage is monitored	6	2.15	2.30	2.45	V
Thermal shutdown temperature	Tth	Design guarantee value *	7	150	180	210	$^\circ\text{C}$
Output block	Turn-on time	TPLH	8		0.2	0.4	μS
	Turn-off time	TPHL	8		0.2	0.4	μS

* : Design guarantee value and no measurement is performed.

Remarks

1. Current consumption when output at the VM pin is off.
2. Current consumption when the V_{CC} pin when in standby mode.
3. Current consumption at the V_{CC} pin when EN is 3V (standby mode).
4. Pins EN1, 2, IN1, 2, 3, and 4 are all pulled down.
5. Sum of upper and lower saturation voltages of OUT pin divided by the current.
6. All power transistors are turned off if a low V_{CC} condition is detected.
7. All output transistors are turned off if the thermal protection circuit is activated. They are turned on again as the temperature goes down.
8. Rising time from 10 to 90% and falling time from 90 to 10% are specified.

Package Dimensions

unit : mm (typ)

3279

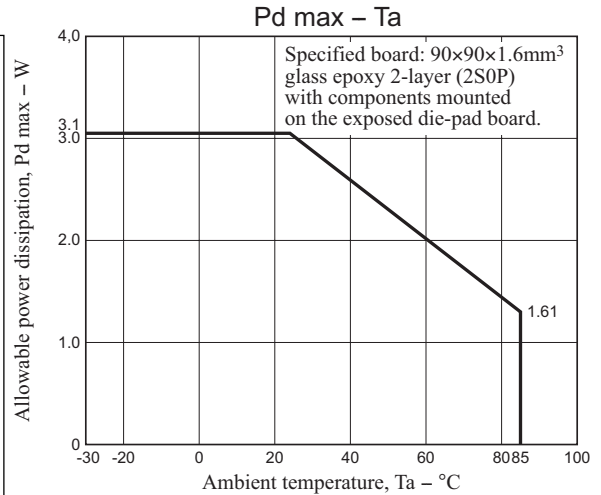
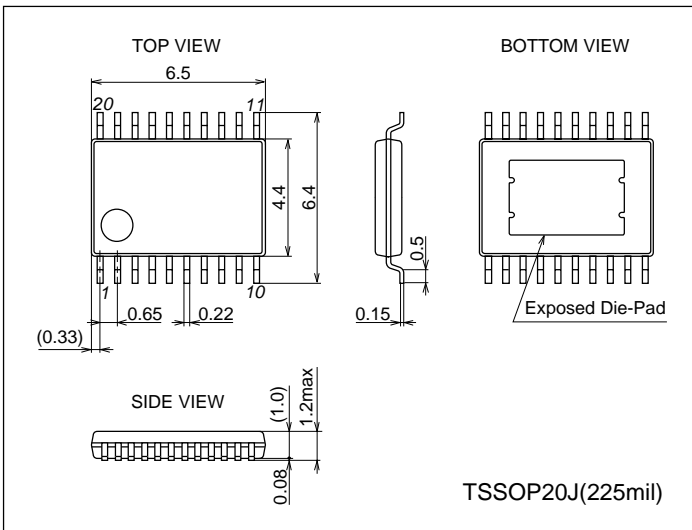

Substrate Specifications

- Size : 90mm × 90mm × 1.6mm (2-layer substrate [2SOP])
- Material : Glass epoxy
- Copper wiring density : L1 = 95% / L2 = 95%

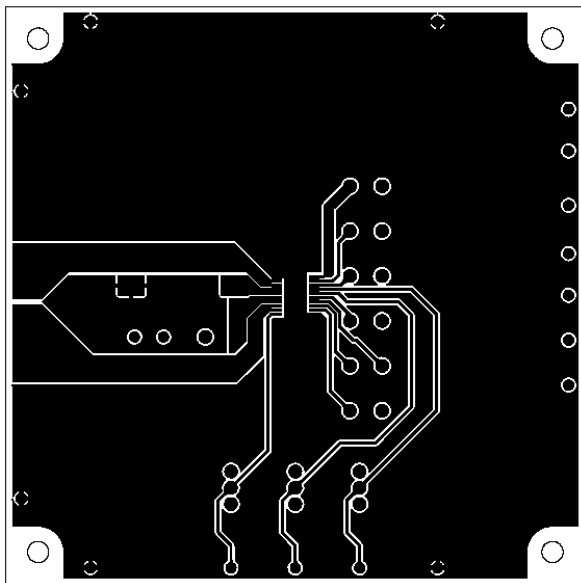

L1 : Copper wiring pattern diagram

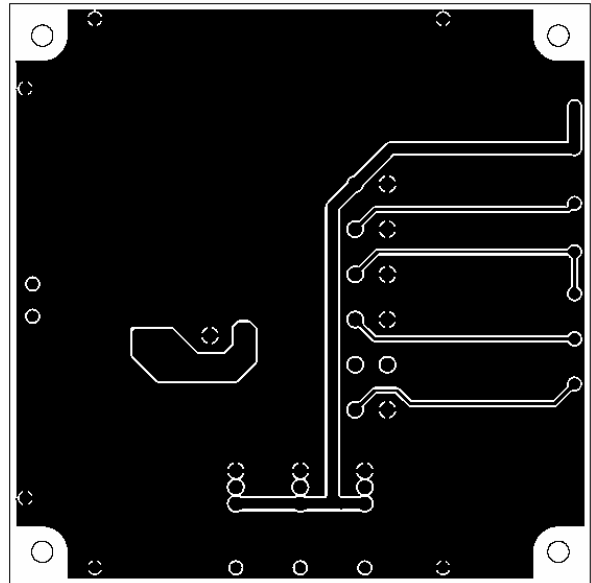

L2 : Copper wiring pattern diagram

Cautions

- 1) The data for the case with the Exposed Die-Pad substrate mounted shows the values when 90% or more of the Exposed Die-Pad is wet.
- 2) For the set design, employ the derating design with sufficient margin.
Stresses to be derated include the voltage, current, junction temperature, power loss, and mechanical stresses such as vibration, impact, and tension. Accordingly, the design must ensure these stresses to be as low or small as possible.
The guideline for ordinary derating is shown below :
 - (1)Maximum value 80% or less for the voltage rating
 - (2)Maximum value 80% or less for the current rating
 - (3)Maximum value 80% or less for the temperature rating
- 3) After the set design, be sure to verify the design with the actual product.
Confirm the solder joint state and verify also the reliability of solder joint for the Exposed Die-Pad, etc.
Any void or deterioration, if observed in the solder joint of these parts, causes deteriorated thermal conduction, possibly resulting in thermal destruction of IC.

LV8406T

Truth Table

EN1 (EN2)	IN1 (IN3)	IN2 (IN4)	OUT1 (OUT3)	OUT2 (OUT4)	Charge pump	Mode
H	H	H	L	L	ON	Brake
	H	L	H	L		Forward
	L	H	L	H		Reverse
	L	L	Z	Z		Standby
L	-	-	Z	Z	OFF	All function stop

- : denotes a don't care value. Z : High-impedance

• In standby mode, consumption current serves as zero..

* All power transistors turn off and the motor stops driving when the IC is detected in low voltage or thermal protection mode.



Pin Functions

Pin No.	Pin name	Description	Equivalent circuit
20 1 17	C1H VG VS	Step-up capacitor connection pin. Charge pump source voltage supply pin.	
19	C1L	Step-up capacitor connection pin.	
16 12 15 14 11 10	EN1 EN2 IN1 IN2 IN3 IN4	Logic enable pin. (Pull-down resistor incorporated) Driver output switching.	
3 4 7 8	OUT1 OUT2 OUT3 OUT4	Driver output.	
2 9	VM1 VM2	Motor block power supply.	
13	VCC	Logic block power supply.	
18	SGND	Control block ground.	
5 6	PGND PGND	Driver block ground.	

ON Semiconductor and the ON logo are registered trademarks of Semiconductor Components Industries, LLC (SCILLC). SCILLC owns the rights to a number of patents, trademarks, copyrights, trade secrets, and other intellectual property. A listing of SCILLC's product/patent coverage may be accessed at www.onsemi.com/site/pdf/Patent-Marking.pdf. SCILLC reserves the right to make changes without further notice to any products herein. SCILLC makes no warranty, representation or guarantee regarding the suitability of its products for any particular purpose, nor does SCILLC assume any liability arising out of the application or use of any product or circuit, and specifically disclaims any and all liability, including without limitation special, consequential or incidental damages. "Typical" parameters which may be provided in SCILLC data sheets and/or specifications can and do vary in different applications and actual performance may vary over time. All operating parameters, including "Typicals" must be validated for each customer application by customer's technical experts. SCILLC does not convey any license under its patent rights nor the rights of others. SCILLC products are not designed, intended, or authorized for use as components in systems intended for surgical implant into the body, or other applications intended to support or sustain life, or for any other application in which the failure of the SCILLC product could create a situation where personal injury or death may occur. Should Buyer purchase or use SCILLC products for any such unintended or unauthorized application, Buyer shall indemnify and hold SCILLC and its officers, employees, subsidiaries, affiliates, and distributors harmless against all claims, costs, damages, and expenses, and reasonable attorney fees arising out of, directly or indirectly, any claim of personal injury or death associated with such unintended or unauthorized use, even if such claim alleges that SCILLC was negligent regarding the design or manufacture of the part. SCILLC is an Equal Opportunity/Affirmative Action Employer. This literature is subject to all applicable copyright laws and is not for resale in any manner.

Looking for pricing, stock, or lifecycle information?

Click below to explore more details on WIN SOURCE:

-  [View LV8406T-MPB-E on WIN SOURCE](#)
-  [ON Semiconductor](#) Information

Optimize Your Supply Chain with WIN SOURCE Solutions

-  Global Sourcing Solution
-  Obsolete Management
-  Cost Control Management
-  Shortage Management
-  Alternative Solution
-  Excess Inventory Management