



LV8013T

Bi-CMOS IC

Forward/Reverse Motor Driver

ON Semiconductor®

<http://onsemi.com>

Overview

LV8013T is a 1ch forward/reverse motor driver IC using D-MOS FET for output stage. As MOS circuit is used, it supports the PWM input. Its features are that the on resistance (0.3Ω typ) and current dissipation are low.

It also provides protection functions such as heat protection circuit and reduced voltage detection and is optimal for the motors that need high-current.

Functions

- 1ch forward/reverse motor driver
- Low power consumption
- Built-in charge pump circuit
- Four mode function forward/reverse, brake, stop.
- Possible to respond to 3V control voltage and 6V motor voltage device
- Low ON resistance 0.5Ω
- Built-in low voltage reset and thermal shutdown circuit

Specifications

Maximum Ratings at $T_a = 25^\circ\text{C}$, $\text{SGND} = \text{PGND} = 0\text{V}$

Parameter	Symbol	Conditions	Ratings	Unit
Supply voltage (For load)	V_M max		-0.5 to 16	V
Supply voltage (For control)	V_{CC} max		-0.5 to 6.0	V
Output current	I_O max	DC	1.2	A
	I_O peak1	$t \leq 100\text{ms}$, $f = 5\text{Hz}$	2.0	A
	I_O peak2	$t \leq 10\text{ms}$, $f = 5\text{Hz}$	3.8	A
Input voltage	V_{IN} max		-0.5 to $V_{CC}+0.5$	V
Allowable power dissipation	P_d max	Mounted on a specified board *	800	mW
Operating temperature	T_{opr}		-20 to +75	$^\circ\text{C}$
Storage temperature	T_{stg}		-55 to +150	$^\circ\text{C}$

*Specified board: 30mm × 50mm × 1.6mm, glass epoxy board.

Caution 1) Absolute maximum ratings represent the value which cannot be exceeded for any length of time.

Caution 2) Even when the device is used within the range of absolute maximum ratings, as a result of continuous usage under high temperature, high current, high voltage, or drastic temperature change, the reliability of the IC may be degraded. Please contact us for the further details.

Stresses exceeding Maximum Ratings may damage the device. Maximum Ratings are stress ratings only. Functional operation above the Recommended Operating Conditions is not implied. Extended exposure to stresses above the Recommended Operating Conditions may affect device reliability.

LV8013T

Allowable Operating Conditions at $T_a = 25^\circ\text{C}$, $\text{SGND} = \text{PGND} = 0\text{V}$

Parameter	Symbol	Conditions	Ratings	Unit
Supply voltage (For load)	VM		2.0 to 15.0	V
Supply voltage (For control)	V _{CC}		2.7 to 5.5	V
Input signal voltage	V _{IN}		0 to V _{CC}	V
Input signal frequency	f max	Duty = 50%	200	kHz
Capacitor for charge pump	C1, C2, CVG1, CVG2		0.001 to 0.1	μF

Electrical Characteristics at $T_a = 25^\circ\text{C}$, $V_{CC} = 5.0\text{V}$, $V_M = 12.0\text{V}$, $\text{SGND} = \text{PGND} = 0\text{V}$, unless especially specified.

Parameter	Symbol	Conditions	Re- marks	Ratings			Unit
				min	typ	max	
Supply current for load at standby 1	IM1	EN = 0V	1			1.0	μA
Supply current for load at standby 2	IM2	V _{CC} = 0V, Each input = 0V	1			1.0	μA
Supply current for control at standby	ICO	EN = 0V, IN1 = IN2 = 0V	2	12.5	25	50	μA
Current drain during operation 1	IC1	V _{CC} = 3.3V, EN = 3.3V, VG at no load	3		0.6	1.0	mA
Current drain during operation 2	IC2	V _{CC} = 5.0V, EN = 5V, VG at no load	3		0.7	1.2	mA
H-level input voltage	V _{IH}	2.7V ≤ V _{CC} ≤ 5.5V		0.6×V _{CC}		V _{CC}	V
L-level input voltage	V _{IL}	2.7V ≤ V _{CC} ≤ 5.5V		0		0.2×V _{CC}	V
H-level input current (IN1, IN2, TIN)	I _{IH}	V _{IN} = 5V	4	12.5	25	50	μA
L-level input current (IN1, IN2, TIN)	I _{IL}	V _{IN} = 0V	4	-1.0			μA
Pull-up resistance (EN)	RUP		4	100	200	400	kΩ
Pull-down resistance (EN)	RDN		4	100	200	400	kΩ
Output ON resistance	RON	Sum of ON resistances at top and bottom	5		0.3	0.5	Ω
Charge pump voltage1	VG1	V _{CC} ×2 - 5.4V CLAMP circuit	6	5.15	5.4	5.65	V
Charge pump voltage2	VG2	VM + VG1 Voltage raising circuit	6	17.1	17.4	17.6	V
Low-voltage detection operation voltage	VCS	V _{CC} voltage	7	2.1	2.25	2.4	V
Thermal shutdown operation temperature	Tth	Design guarantee	8	150	180	210	°C
Charge pump capacity 1	VG1LOAD	IG1 = 500μA	9	5.0	5.3		V
Charge pump capacity 2	VG2LOAD	IG2 = 500μA	9	16.0	16.5		V
IG current dissipation (Fin = 20kHz)	IG		10			350	μA
Charge pump start time	TVG	CVG = 0.1μF	11			1.0	ms
Output block	Turn on time	TPLH	12		0.5	1.0	μs
	Turn off time	TPHL	12		0.5	1.0	μs
TOUT	Turn on time	TON	12		0.5	20	μs
	Turn off time	TOFF	12		0.5	20	μs
TOUT output voltage H	TOH	C = 500pF		VG2-0.1	VG2		V
TOUT output voltage L	TOL	C = 500pF			0.05	0.1	V

* Design guarantee : This characteristics is not measured.

Refer to next page for remarks.

LV8013T

Remarks

1. It shows current dissipation of VM pin in output OFF state.
2. It shows current dissipation of VCC pin in stand-by state.
(The standard current depends on EN pin pull-down resistor.)
3. It shows current dissipation of VCC pin in state of EN = 5V (stand-by), including current dissipation of VG pin.
4. IN1, IN2 and TIN pin are built-in pull-down resistor, EN pin is built-in pull-up resistor.
5. It shows sum of upper and lower saturation voltages of OUT pin.
6. It controls charge-pump oscillation and makes specified voltage.
7. When low voltage is detected, the lower output is turned OFF.
8. When thermal protection circuit is activated, the lower output is turned OFF.
When the heat temperature is fallen, it is turned ON again.
9. IG (VG pin load current) = 500 μ A
10. It shows VG pin current dissipation in state of PWM input for IN pin.
11. It specifies start-up time from 10% to 90% when VG is in non-load state
(when setting the capacitor between VG and GND to 0.1 μ F and VCC is 5V).
12. It specifies 10% to 90% for start-up and 90% to 10% for shut-down.

Package Dimensions

unit : mm (typ)

3260A

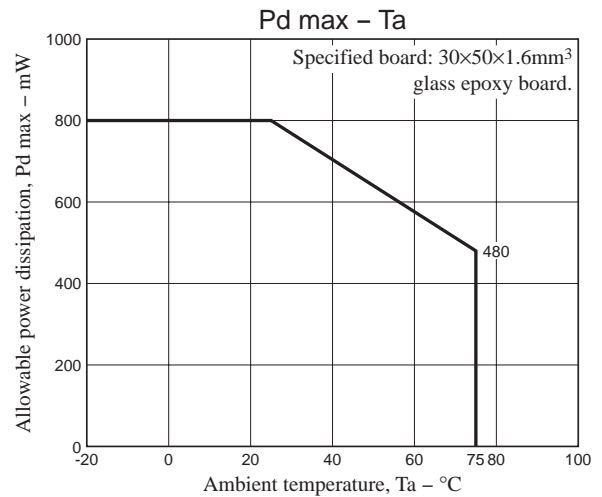
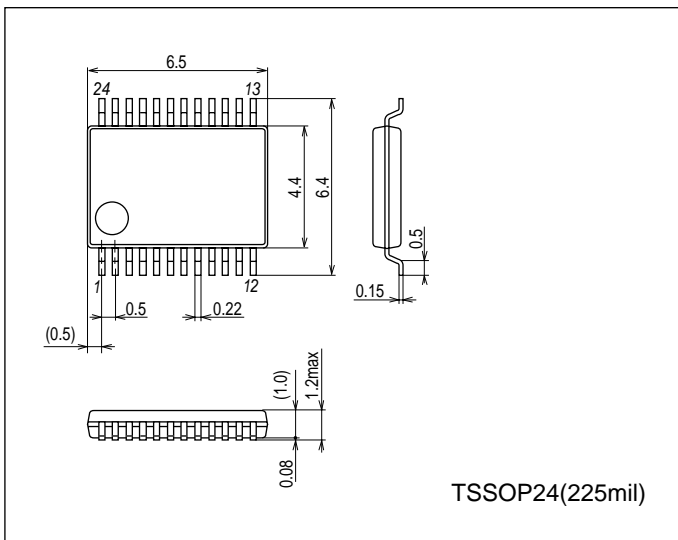

Pin Assignment

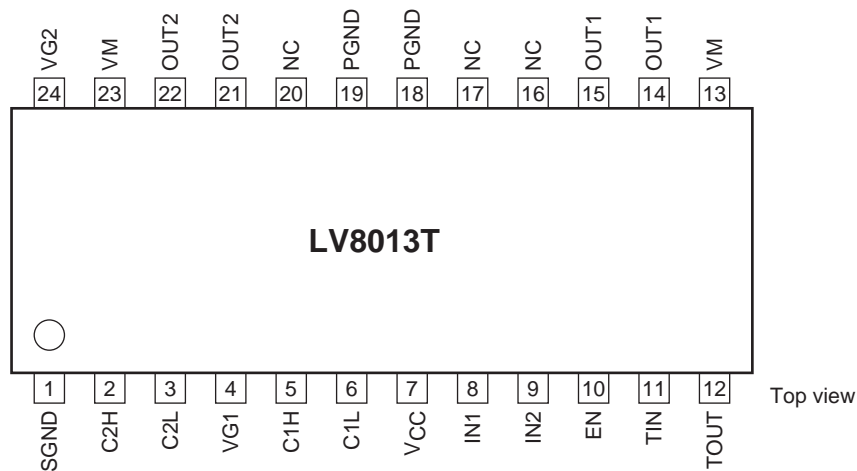

LV8013T

Block Diagram

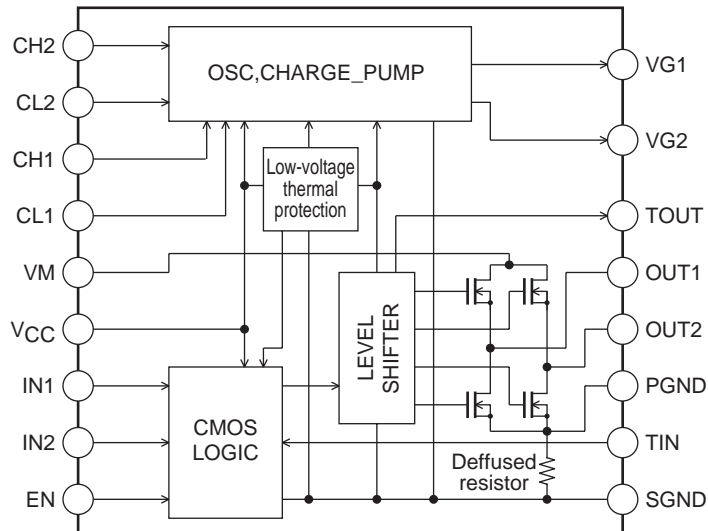

Truth Table

EN	IN1	IN2	TIN	OUT1	OUT2	TOUT	Charge Pump	Mode
H	H	H	-	L	L	-	ON	Brake
	H	L	-	H	L	-		Forward
	L	H	-	L	H	-		Reverse
	L	L	-	Z	Z	-		Standby
	-	-	L	-	-	L		Tr-OFF
	-	-	H	-	-	H		Tr-ON
L	-	-	-	L	L	L	OFF	Standby

- : Don't care, Z : High-Impedance

- Current drain becomes zero in the standby mode. (Leak current from EN pin is excluded)
- The output side becomes OFF, with motor drive stopped, during voltage reduction and thermal protection. Also, the charge of VG2 is discharged with an internal circuit at decreasing voltage.

Pin Function

Pin No.	Pin name	Function	Equivalent circuit
6	C1L	Voltage raising capacitor connection pin.	
5	C1H	Voltage raising capacitor connection pin.	
8 9 11	IN1 IN2 TIN	<ul style="list-style-type: none"> • Driver output changeover. • TOUT output control pin. (Built-in pull-down resistor) 	

Continued on next page.

LV8013T

Continued from preceding page.

Pin No.	Pin name	Function	Equivalent circuit
10	EN	Logic enable pin. (Built-in pull-up resistor)	
14 15 21 22 18 19	OUT1 OUT1 OUT2 OUT2 PGND PGND	Driver output pin.	
12	TOUT	Voltage raising output pin.	
13 23	VM VM	Motor power supply. (both terminals to be connected)	
7	VCC	Logic power supply.	
4	VG1	Voltage raising circuit 1. $V_{CC} \times 2$ Clamped to 5.4V	
24 2 3	VG2 C2H C2L	<ul style="list-style-type: none"> Voltage raising circuit 2. $VM + VG1$ Voltage raising capacitor connection pin. VG2 is discharged in abnormal. 	
1	SGND	Logic GND	
18 19	PGND PGND	Driver GND (both terminals to be connected)	

Application Circuit Example

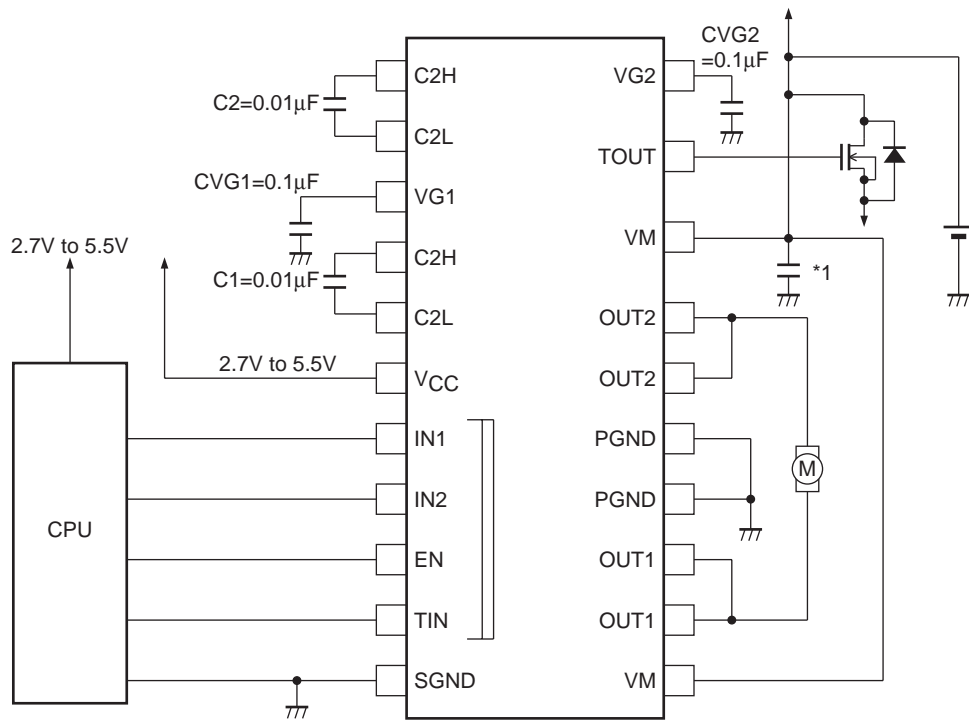

*1 : Connect a kickback absorption capacitor directly near IC. Coil kick-back may cause rise of the voltage of VM line, and the voltage exceeding the maximum rating may be applied momentarily, resulting in deterioration or damage of IC.

ON Semiconductor and the ON logo are registered trademarks of Semiconductor Components Industries, LLC (SCILLC). SCILLC owns the rights to a number of patents, trademarks, copyrights, trade secrets, and other intellectual property. A listing of SCILLC's product/patent coverage may be accessed at www.onsemi.com/site/pdf/Patent-Marking.pdf. SCILLC reserves the right to make changes without further notice to any products herein. SCILLC makes no warranty, representation or guarantee regarding the suitability of its products for any particular purpose, nor does SCILLC assume any liability arising out of the application or use of any product or circuit, and specifically disclaims any and all liability, including without limitation special, consequential or incidental damages. "Typical" parameters which may be provided in SCILLC data sheets and/or specifications can and do vary in different applications and actual performance may vary over time. All operating parameters, including "Typicals" must be validated for each customer application by customer's technical experts. SCILLC does not convey any license under its patent rights nor the rights of others. SCILLC products are not designed, intended, or authorized for use as components in systems intended for surgical implant into the body, or other applications intended to support or sustain life, or for any other application in which the failure of the SCILLC product could create a situation where personal injury or death may occur. Should Buyer purchase or use SCILLC products for any such unintended or unauthorized application, Buyer shall indemnify and hold SCILLC and its officers, employees, subsidiaries, affiliates, and distributors harmless against all claims, costs, damages, and expenses, and reasonable attorney fees arising out of, directly or indirectly, any claim of personal injury or death associated with such unintended or unauthorized use, even if such claim alleges that SCILLC was negligent regarding the design or manufacture of the part. SCILLC is an Equal Opportunity/Affirmative Action Employer. This literature is subject to all applicable copyright laws and is not for resale in any manner.

Looking for pricing, stock, or lifecycle information?

Click below to explore more details on WIN SOURCE:

- ⊖ [View LV8013T-A-MPB-E on WIN SOURCE](#)
- ⊖ [ON Semiconductor](#) Information

Optimize Your Supply Chain with WIN SOURCE Solutions

- ✓ Global Sourcing Solution
- ✓ Obsolete Management
- ✓ Cost Control Management
- ✓ Shortage Management
- ✓ Alternative Solution
- ✓ Excess Inventory Management