



# LV8012T

Bi-CMOS LSI

## Forward/Reverse Motor Driver

ON Semiconductor®

<http://onsemi.com>

### Overview

LV8012T is a 2ch forward/reverse motor driver IC using D-MOS FET for output stage. As MOS circuit is used, it supports the PWM input. Its features are that the on resistance ( $0.75\Omega$  typ) and current dissipation are low. It also provides protection functions such as heat protection circuit and reduced voltage detection and is optimal for the motors that need high-current.

### Functions

- 2ch forward/reverse motor driver
- Low power consumption
- Built-in charge pump circuit
- Compact TSSOP-24 package
- Possible to respond to 3V control voltage and 6V motor voltage device
- Low ON resistance  $1.2\Omega$
- Built-in low voltage reset and thermal shutdown circuit
- Four mode function forward/reverse, brake, stop.

### Specifications

**Absolute Maximum Ratings** at  $T_a = 25^\circ\text{C}$ ,  $\text{SGND} = \text{PGND} = 0\text{V}$

Parameter	Symbol	Conditions	Ratings	Unit
Supply voltage (For load)	$V_M$ max		-0.5 to 7.5	V
Supply voltage (For control)	$V_{CC}$ max		-0.5 to 6.0	V
Output current	$I_O$ max	$t \leq 100\text{ms}$	1.4	A
Input voltage	$V_{IN}$ max		-0.5 to $V_{CC}+0.5$	V
Allowable power dissipation	$P_d$	* Mounted on a substrate	800	mW
Operating temperature	$T_{opr}$		-20 to +75	$^\circ\text{C}$
Storage temperature	$T_{stg}$		-55 to +150	$^\circ\text{C}$

\* : Mounted on a substrate :  $30 \times 50 \times 1.6\text{mm}^3$ , glass epoxy board

Caution 1) Absolute maximum ratings represent the value which cannot be exceeded for any length of time.

Caution 2) Even when the device is used within the range of absolute maximum ratings, as a result of continuous usage under high temperature, high current, high voltage, or drastic temperature change, the reliability of the IC may be degraded. Please contact us for the further details.

Stresses exceeding Maximum Ratings may damage the device. Maximum Ratings are stress ratings only. Functional operation above the Recommended Operating Conditions is not implied. Extended exposure to stresses above the Recommended Operating Conditions may affect device reliability.

# LV8012T

## Allowable Operating Ratings at $T_a = 25^\circ\text{C}$ , $\text{SGND} = \text{PGND} = 0\text{V}$

Parameter	Symbol	Conditions	Ratings	Unit
Supply voltage (VM Pin)	VM		2.0 to 7.0	V
Supply voltage ( $V_{CC}$ Pin)	$V_{CC}$		2.7 to 5.5	
Input signal voltage	$V_{IN}$		0 to $V_{CC}$	V
Input signal frequenc	f max		100	kHz
Capacitor for charge pump	C1, C2, C3		0.001 to 0.1	$\mu\text{F}$

## Electrical Characteristics at $T_a = 25^\circ\text{C}$ , $V_{CC} = \text{VM} = 5.0\text{V}$ , $\text{SGND} = \text{PGND} = 0\text{V}$ , unless especially specified.

Parameter	Symbol	Conditions	Remarks	Ratings			Unit
				min	typ	max	
Supply current for load at standby	IMO	EN = 0V	1			1.0	$\mu\text{A}$
Supply current for control at standby	ICO	EN = 0V, IN1 = IN2 = IN3 = IN4 = 0V	2			1.0	$\mu\text{A}$
Current drain during operation	IC1	EN = 5V, VG at no load	3		0.7	1.2	mA
H-level input voltage	$V_{IH}$	$2.7\text{V} \leq V_{CC} \leq 5.5\text{V}$		$0.6 \times V_{CC}$		$V_{CC}$	V
L-level input voltage	$V_{IL}$	$2.7\text{V} \leq V_{CC} \leq 5.5\text{V}$		0		$0.2 \times V_{CC}$	V
H-level input current (IN1, IN2, IN3, IN4)	$I_{IH}$		4			1.0	$\mu\text{A}$
L-level input current (IN1, IN2, IN3, IN4)	$I_{IL}$		4	-1.0			$\mu\text{A}$
Pull-down resistance (EN1, 2)	RUP			100	200	400	$\text{k}\Omega$
Output ON resistance	RON	Sum of ON resistances at top and bottom	5		0.75	1.2	$\Omega$
Charge pump voltage	VG		6	8.5		10.5	V
Low-voltage detection operation voltage	VCS		7	2.15	2.30	2.45	V
Thermal shutdown operation temperature	$T_{TSD}$		8		180		$^\circ\text{C}$
Charge pump capacity (IG = 500 $\mu\text{A}$ )	VGLOAD		9	8	9		V
IG current dissipation (Fin = 20kHz)	IG		10			350	$\mu\text{A}$
Charge pump start time	TVG	CVG = 0.1 $\mu\text{F}$	11			1.0	ms
Output block	Turn on time	TPLH	12		0.2	0.4	$\mu\text{s}$
	Turn off time	TPHL	12		0.2	0.4	$\mu\text{s}$

### Remarks

1. It shows current dissipation of VM pin in output OFF state.
2. It shows current dissipation of  $V_{CC}$  pin in stand-by state.  
(The standard current depends on EN pin pull-down resistance.)
3. It shows current dissipation of  $V_{CC}$  pin in state of EN = 5V (stand-by), including current dissipation of VG pin.
4. For IN1, IN2, IN3 and IN4 pins, no pull-down and pull-up resistance is needed. (High impedance pin)
5. It shows sum of upper and lower saturation voltages of OUT pin.
6. It controls charge-pump oscillation and makes specified voltage.
7. When low voltage is detected, the lower output is turned OFF.
8. When thermal protection circuit is activated, the lower output is turned OFF.  
When the heat temperature is fallen, it is turned ON again.
9. IG (VG pin load current) = 500 $\mu\text{A}$
10. It shows VG pin current dissipation in state of PWM input for IN pin.
11. It specifies start-up time from 10% to 90% when VG is in non-load state  
(when setting the capacitor between VG and GND to 0.1 $\mu\text{F}$  and  $V_{CC}$  is 5V).
12. It specifies 10% to 90% for start-up and 90% to 10% for shut-down.

# LV8012T

## Package Dimensions

unit : mm (typ)  
3260A

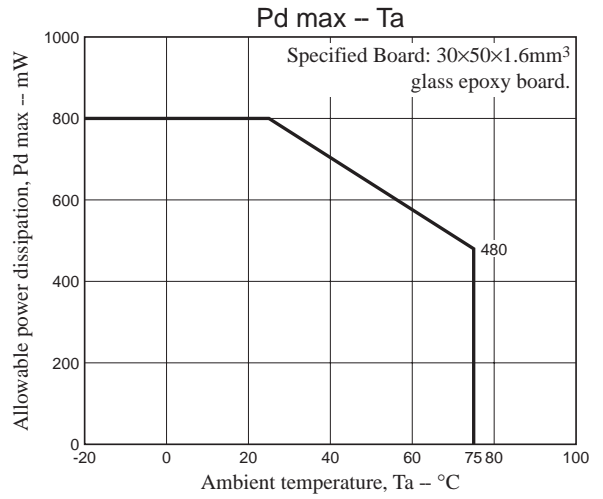
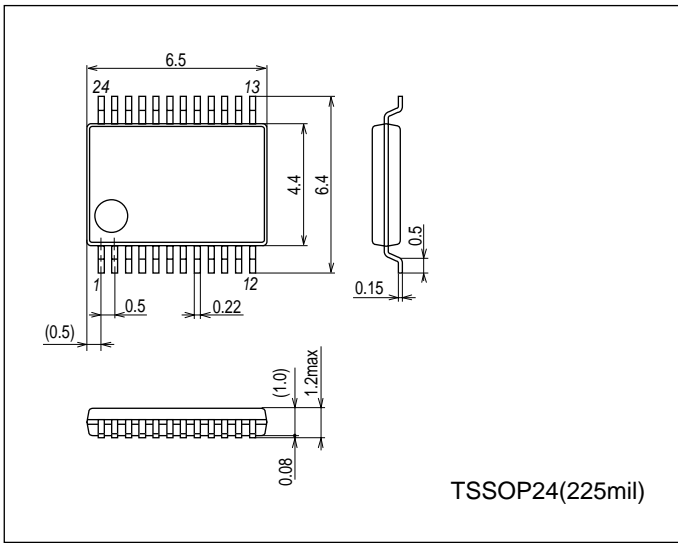

## Pin Assignment

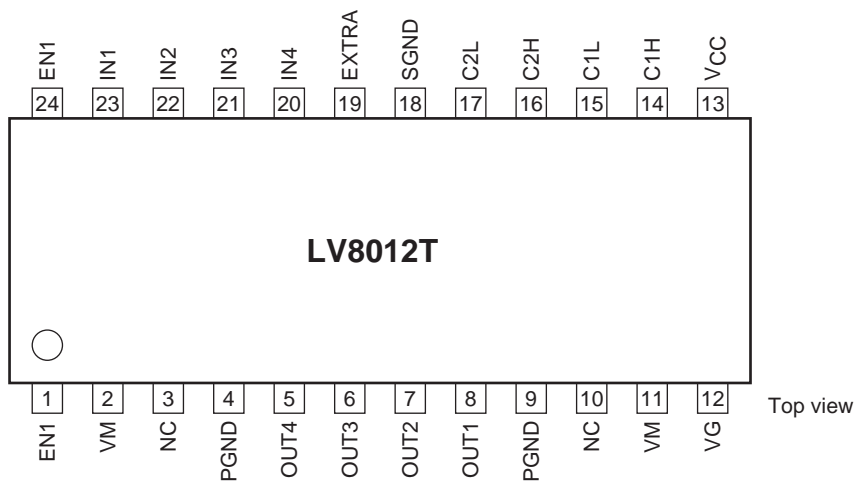

# LV8012T

## Block Diagram

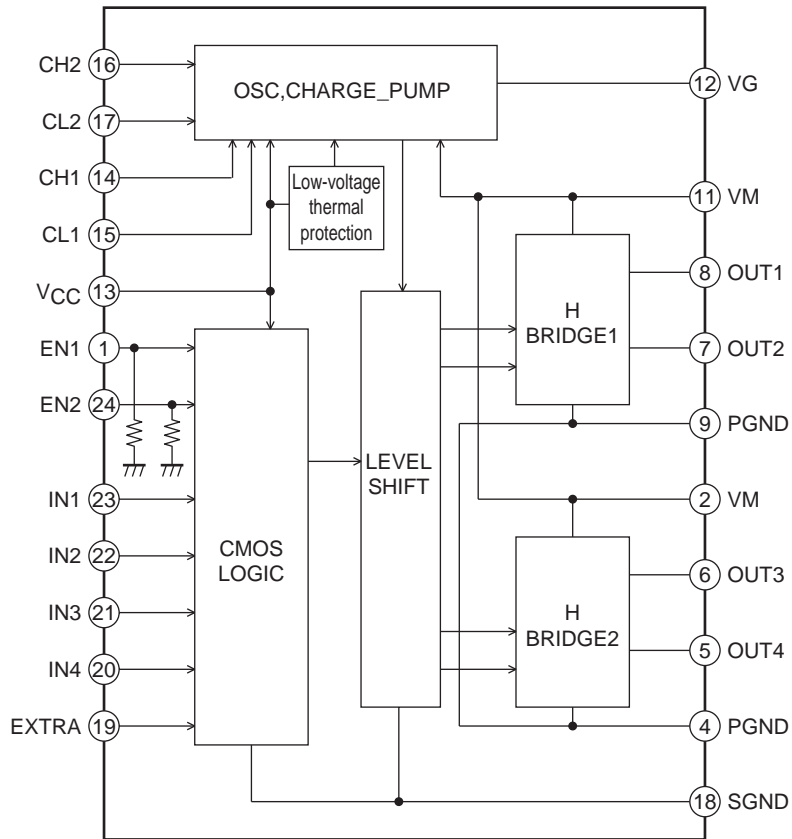

## Truth table

EXTRA	EN1 (EN2)	IN1 (IN3)	IN2 (IN4)	OUT1 (OUT3)	OUT2 (OUT4)	Circuit of Charge Pump	Mode
L	H	H	H	Z	Z	ON	Standby
		H	L	L	H		Reverse
		L	H	H	L		Forward
		L	L	L	L		Brake
	L	-	-	L	L	OFF	Standby
H	H	H	-	L	H	ON	Reverse
		L	-	H	L		Forward
	L	-	-	L	L	Brake	

- : Don't care Z : High-Impedance

\* Current drain becomes zero in the standby mode.

\* The output side becomes OFF, with motor drive stopped, during voltage reduction and thermal protection.

# LV8012T

## Pin Functions

Pin No.	Pin name	Function	Equivalent Circuit
15 17	C1L C2L	Voltage raising capacitor connection pin	
14 16	C1H C2H	Voltage raising capacitor connection pin	
23 22 21 20 19	IN1 IN2 IN3 IN4 EXTRA	Driver output changeover	
1 24	EN1 EN2	Logic enable pin TOOUT output control pin (Pull-down resistor incorporated)	
8 7 6 5	OUT1 OUT2 OUT3 OUT4 PGND	Driver output pin	
2 11	VM VM	Motor power supply (both terminals to be connected)	
13	VCC	Logic power supply	
12	VG	Driver drive circuit power supply	
18	SGND	Logic GND	
9 4	PGND PGND	Driver GND (both terminals to be connected)	

Sample Application Circuit

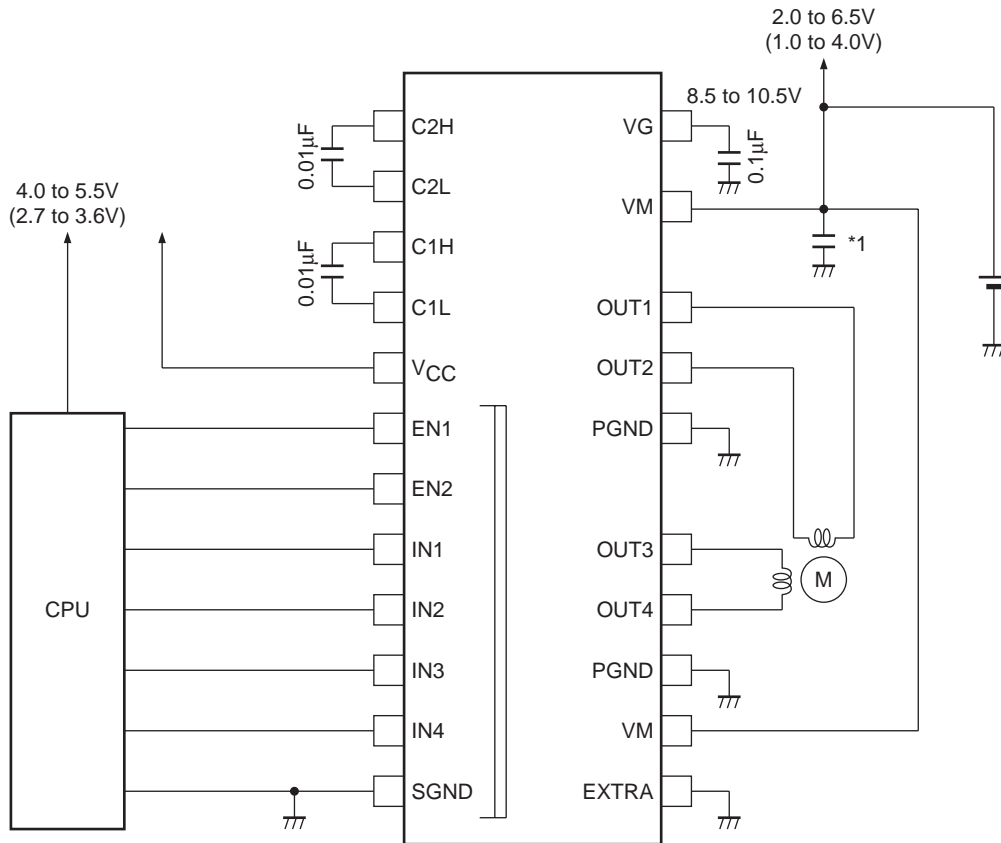



\*1 : Connect a kickback absorption capacitor directly near IC. Coil kickback may cause rise of the voltage of VM line, and the voltage exceeding the maximum rating may be applied momentarily, resulting in deterioration or damage of IC.

ON Semiconductor and the ON logo are registered trademarks of Semiconductor Components Industries, LLC (SCILLC). SCILLC owns the rights to a number of patents, trademarks, copyrights, trade secrets, and other intellectual property. A listing of SCILLC's product/patent coverage may be accessed at [www.onsemi.com/site/pdf/Patent-Marking.pdf](http://www.onsemi.com/site/pdf/Patent-Marking.pdf). SCILLC reserves the right to make changes without further notice to any products herein. SCILLC makes no warranty, representation or guarantee regarding the suitability of its products for any particular purpose, nor does SCILLC assume any liability arising out of the application or use of any product or circuit, and specifically disclaims any and all liability, including without limitation special, consequential or incidental damages. "Typical" parameters which may be provided in SCILLC data sheets and/or specifications can and do vary in different applications and actual performance may vary over time. All operating parameters, including "Typicals" must be validated for each customer application by customer's technical experts. SCILLC does not convey any license under its patent rights nor the rights of others. SCILLC products are not designed, intended, or authorized for use as components in systems intended for surgical implant into the body, or other applications intended to support or sustain life, or for any other application in which the failure of the SCILLC product could create a situation where personal injury or death may occur. Should Buyer purchase or use SCILLC products for any such unintended or unauthorized application, Buyer shall indemnify and hold SCILLC and its officers, employees, subsidiaries, affiliates, and distributors harmless against all claims, costs, damages, and expenses, and reasonable attorney fees arising out of, directly or indirectly, any claim of personal injury or death associated with such unintended or unauthorized use, even if such claim alleges that SCILLC was negligent regarding the design or manufacture of the part. SCILLC is an Equal Opportunity/Affirmative Action Employer. This literature is subject to all applicable copyright laws and is not for resale in any manner.

## Looking for pricing, stock, or lifecycle information?

Click below to explore more details on WIN SOURCE:

-  [View LV8012T-MPB-E on WIN SOURCE](#)
-  [ON Semiconductor](#) Information

## Optimize Your Supply Chain with WIN SOURCE Solutions

-  Global Sourcing Solution
-  Obsolete Management
-  Cost Control Management
-  Shortage Management
-  Alternative Solution
-  Excess Inventory Management