



**THE DATASHEET OF
LTM8022EV#PBF(LTM8022V)**



FEATURES

- Complete Step-Down Switch Mode Power Supply
- Wide Input Voltage Range: 3.6V to 36V
- 0.8V to 10V Output Voltage
- 1A Output Current
- Adjustable Switching Frequency: 200kHz to 2.4MHz
- Current Mode Control
- (e4) RoHS Compliant Package with Gold Pad Finish
- Programmable Soft-Start
- Tiny, Low Profile (11.25mm \times 9mm \times 2.82mm) Surface Mount LGA Package

APPLICATIONS

- Automotive Battery Regulation
- Power for Portable Products
- Distributed Supply Regulation
- Industrial Supplies
- Wall Transformer Regulation

DESCRIPTION

The LTM[®]8022 is a complete 1A, DC/DC step-down power supply. Included in the package are the switching controller, power switches, inductor, and all support components. Operating over an input voltage range of 3.6V to 36V, the LTM8022 supports an output voltage range of 0.8V to 10V, and a switching frequency range of 200kHz to 2.4MHz, each set by a single resistor. Only the bulk input and output filter capacitors are needed to finish the design.

The low profile package (2.82mm) enables utilization of unused space on the bottom of PC boards for high density point of load regulation.

The LTM8022 is packaged in a thermally enhanced, compact (11.25mm \times 9mm) and low profile (2.82mm) overmolded land grid array (LGA) package suitable for automated assembly by standard surface mount equipment. The LTM8022 is RoHS compliant.

LT, LT, LTC, LTM, Linear Technology, Burst Mode and the Linear logo are registered trademarks of Linear Technology Corporation. All other trademarks are the property of their respective owners.

TYPICAL APPLICATION

7V_{IN} to 36V_{IN}, 5V/1A μ Module[®] Regulator

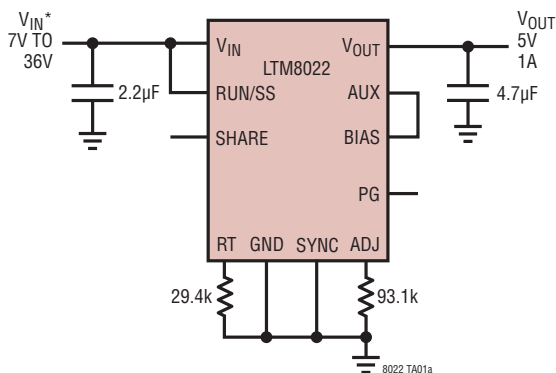

*RUNNING VOLTAGE RANGE. PLEASE REFER TO APPLICATIONS INFORMATION FOR START-UP DETAILS

Efficiency and Power Loss

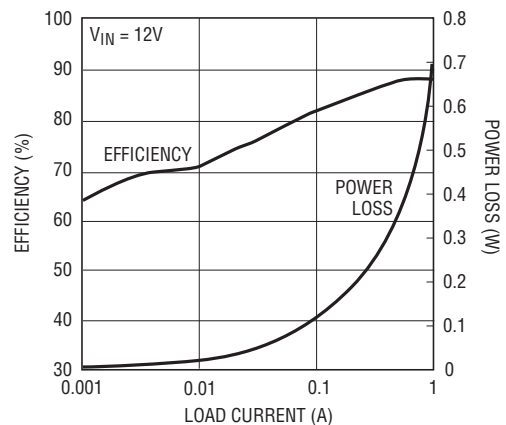

8022 TA01b

LTM8022

ABSOLUTE MAXIMUM RATINGS

(Note 1)

V_{IN} , RUN/SS Voltage.....	40V
ADJ, R_T , SHARE, Voltage	5V
V_{OUT} , AUX.....	10V
SYNC, PG.....	30V
BIAS.....	16V
V_{IN} + BIAS.....	56V
Internal Operating Temperature.....	-40°C to 125°C
Solder Temperature.....	250°C
Storage Temperature.....	-55°C to 125°C

PIN CONFIGURATION

(See Table 3, Pin Assignment)

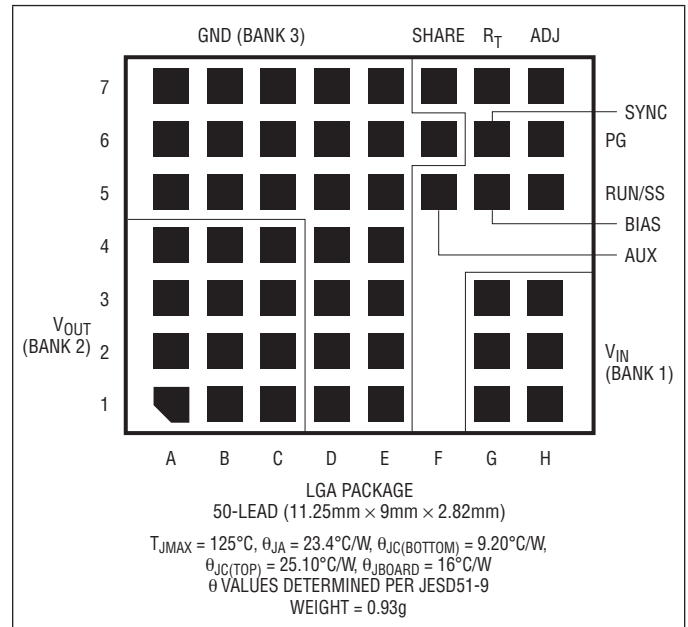

ORDER INFORMATION

LEAD FREE FINISH	PART MARKING*	PACKAGE DESCRIPTION	TEMPERATURE RANGE (Note 2)
LTM8022EV#PBF	LTM8022V	50-Pin (11.25mm × 9mm × 2.82mm) LGA	-40°C to 85°C
LTM8022IV#PBF	LTM8022V	50-Pin (11.25mm × 9mm × 2.82mm) LGA	-40°C to 85°C
LTM8022MPV#PBF	LTM8022MPV	50-Pin (11.25mm × 9mm × 2.82mm) LGA	-55°C to 125°C

Consult LTC Marketing for parts specified with wider operating temperature ranges. *The temperature grade is identified by a label on the shipping container. Consult LTC Marketing for information on non-standard lead based finish parts.

For more information on lead free part marking, go to: <http://www.linear.com/leadfree/>
 This product is only offered in trays. For more information go to: <http://linear.com/packaging/>

ELECTRICAL CHARACTERISTICS

The ● denotes the specifications which apply over the full operating temperature range, otherwise specifications are at $T_A = 25^\circ\text{C}$. $V_{IN} = 10\text{V}$, $V_{RUN/SS} = 10\text{V}$, $V_{BIAS} = 3\text{V}$, $R_T = 60.4\text{k}\Omega$, $C_{IN} = 2.2\mu\text{F}$, $C_{OUT} = 4.7\mu\text{F}$, unless otherwise specified. (Note 2)

SYMBOL	PARAMETER	CONDITIONS	MIN	TYP	MAX	UNITS
V_{IN}	Input DC Voltage		● 3.6		36	V
V_{OUT}	Output DC Voltage	$0\text{V} < I_{OUT} < 1\text{A}$, R_{ADJ} Open $0\text{V} < I_{OUT} < 1\text{A}$, $R_{ADJ} = 43.2\text{k}$		0.8 10		V V
$R_{ADJ(MIN)}$	Minimum Allowable R_{ADJ}	(Note 3)	42.2			$\text{k}\Omega$
$I_{OUT(MAX)}$	Continuous Output DC Current	$4\text{V} < V_{IN} < 36\text{V}$, $C_{OUT} = 51\mu\text{F}$ (Note 4)	0		1	A
I_{QVIN}	V_{IN} Quiescent Current	$V_{RUN/SS} = 0.2\text{V}$, $R_T = 174\text{k}$ $V_{BIAS} = 3\text{V}$, Not Switching, $R_T = 174\text{k}$ (E, I) ● $V_{BIAS} = 3\text{V}$, Not Switching, $R_T = 174\text{k}$ (MP) ● $V_{BIAS} = 0\text{V}$, Not Switching, $R_T = 174\text{k}$		0.1 25 25 85	0.5 60 350 120	μA μA μA μA
I_{QBIAS}	BIAS Quiescent Current	$V_{RUN/SS} = 0.2\text{V}$, $R_T = 174\text{k}$ $V_{BIAS} = 3\text{V}$, Not Switching, $R_T = 174\text{k}$ (E, I) ● $V_{BIAS} = 3\text{V}$, Not Switching, $R_T = 174\text{k}$ (MP) ● $V_{BIAS} = 0\text{V}$, Not Switching, $R_T = 174\text{k}$		0.03 50 50 1	0.5 120 200 5	μA μA μA μA
$\Delta V_{OUT}/V_{OUT}$	Line Regulation	$3.6\text{V} < V_{IN} < 36\text{V}$, $I_{OUT} = 1\text{A}$, $V_{OUT} = 3.3\text{V}$		0.1		%
$\Delta V_{OUT}/V_{OUT}$	Load Regulation	$V_{IN} = 24\text{V}$, $0\text{V} < I_{OUT} < 1\text{A}$, $V_{OUT} = 3.3\text{V}$, $C_{OUT} = 51\mu\text{F}$		0.4		%
$V_{OUT(AC_RMS)}$	Output Ripple (RMS)	$V_{IN} = 24\text{V}$, $I_{OUT} = 1\text{A}$, $V_{OUT} = 3.3\text{V}$, $C_{OUT} = 51\mu\text{F}$		10		mV
f_{SW}	Switching Frequency	$R_T = 113\text{k}\Omega$, $C_{OUT} = 51\mu\text{F}$		325		kHz
$I_{SC(OUT)}$	Output Short-Circuit Current	$V_{IN} = 36\text{V}$, $V_{OUT} = 0\text{V}$ (Note 5)		3		A
V_{ADJ}	Voltage at ADJ Pin	$C_{OUT} = 51\mu\text{F}$	● 765	790	805	mV
$V_{BIAS(MIN)}$	Minimum BIAS Voltage for Proper Operation			1.9	2.4	V
I_{ADJ}	Current Out of ADJ Pin	$ADJ = 1\text{V}$, $C_{OUT} = 51\mu\text{F}$		2		μA
$I_{RUN/SS}$	RUN/SS Pin Current	$V_{RUN/SS} = 2.5\text{V}$		5	10	μA
$V_{IH(RUN/SS)}$	RUN/SS Input High Voltage	$C_{OUT} = 51\mu\text{F}$	2.5			V
$V_{IL(RUN/SS)}$	RUN/SS Input Low Voltage	$C_{OUT} = 51\mu\text{F}$			0.2	V
$V_{PG(TH)}$	PG Threshold	V_{FB} Rising		730		mV
I_{PGO}	PG Leakage	$V_{PG} = 30\text{V}$		0.1	1	μA
$I_{PG(SINK)}$	PG Sink Current	$V_{PG} = 0.4\text{V}$	200	800		μA
$V_{SYNC(IL)}$	SYNC Low Threshold	$f_{SYNC} = 550\text{kHz}$, $C_{OUT} = 51\mu\text{F}$	0.5			V
$V_{SYNC(IH)}$	SYNC High Threshold	$f_{SYNC} = 550\text{kHz}$, $C_{OUT} = 51\mu\text{F}$			0.7	V
$I_{SYNC(BIAS)}$	SYNC Pin Bias Current	$V_{SYNC} = 0\text{V}$		0.1		μA

Note 1: Stresses beyond those listed under Absolute Maximum Ratings may cause permanent damage to the device. Exposure to any Absolute Maximum Rating condition for extended periods may affect device reliability and lifetime.

Note 2: The LTM8022E is guaranteed to meet performance specifications from 0°C to 85°C ambient. Specifications over the full -40°C to 85°C ambient operating temperature range are assured by design, characterization and correlation with statistical process controls. The LTM8022I is guaranteed to meet specifications over the full -40°C to 85°C ambient operating temperature range. The LTM8022MP is guaranteed to

meet specifications over the full -55°C to 125°C temperature range. Note that the maximum internal temperature is determined by specific operating conditions in conjunction with board layout, the rated package thermal resistance and other environmental factors.

Note 3: Guaranteed by design.

Note 4: $C_{OUT} = 51\mu\text{F}$ is composed of a $4.7\mu\text{F}$ ceramic capacitor and a $47\mu\text{F}$ electrolytic.

Note 5: Short circuit current at $V_{IN} = 36\text{V}$ is guaranteed by characterization and correlation. 100% tested at $V_{IN} = 10\text{V}$.

TYPICAL PERFORMANCE CHARACTERISTICS ($T_A = 25^\circ\text{C}$, unless otherwise noted)

Efficiency vs Load (8V_{OUT})

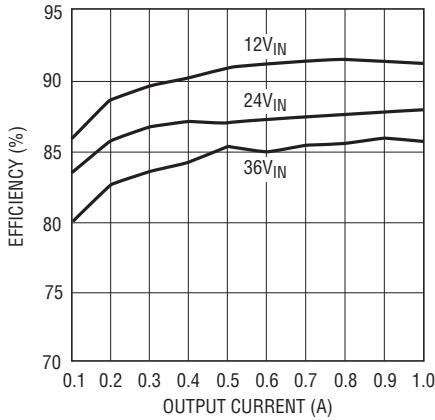

8022 G01

Efficiency vs Load (5V_{OUT})

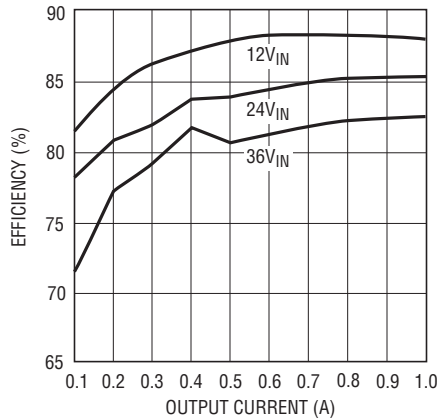

8022 G02

Efficiency vs Load (3.3V_{OUT})

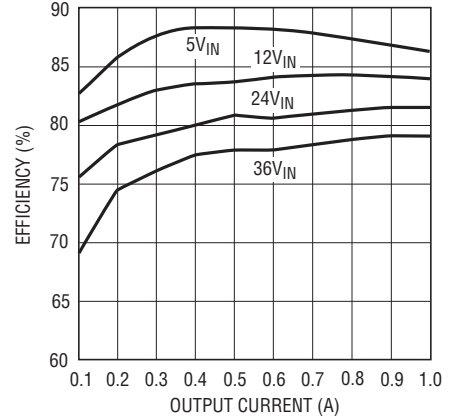

8022 G03

Minimum Required Input Voltage vs Output Voltage, I_{OUT} = 1A

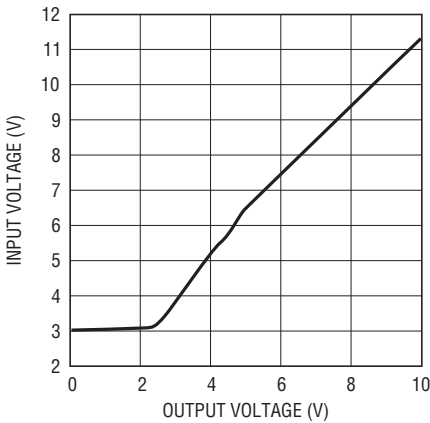

8022 G04

Output Start-up Waveform V_{IN} = 36V, 5V_{OUT}, I_{OUT} = 1A

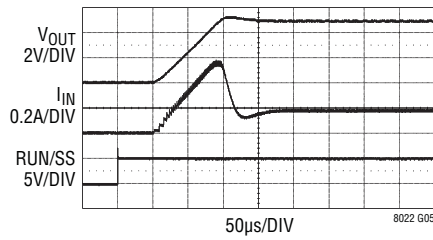

8022 G05

Output Start-up Waveform V_{IN} = 36V, 3.3V_{OUT}, I_{OUT} = 1A

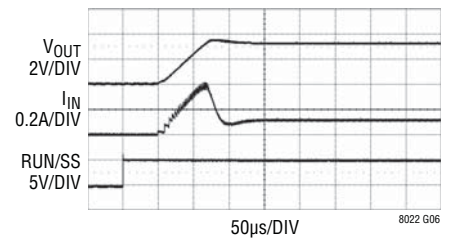

8022 G06

Input Current vs Output Current (8V_{OUT})

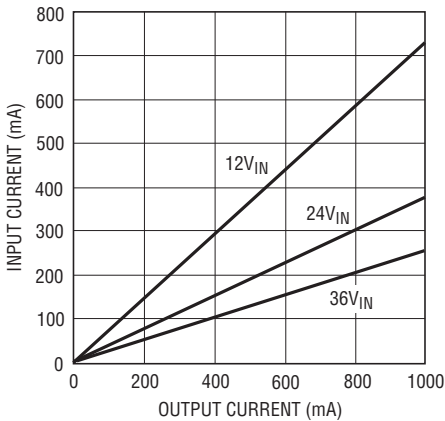

8022 G07

Input Current vs Output Current (5V_{OUT})

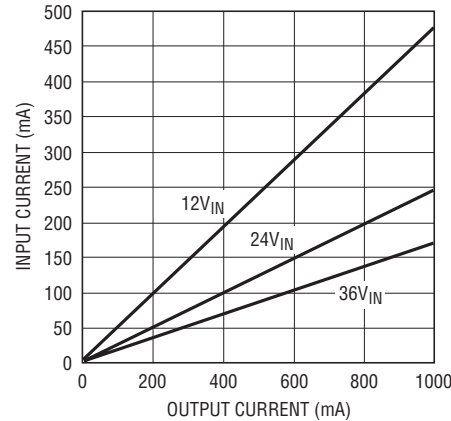

8022 G08

Input Current vs Output Current (3.3V_{OUT})

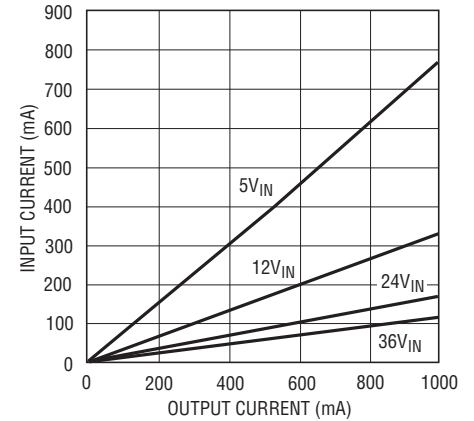

8022 G09

TYPICAL PERFORMANCE CHARACTERISTICS ($T_A = 25^\circ\text{C}$, unless otherwise noted)

Output Current vs Input Voltage (Output Short)

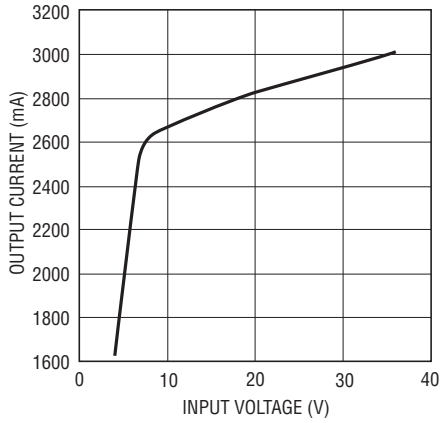

8022 G10

BIAS Quiescent Current vs Load Current

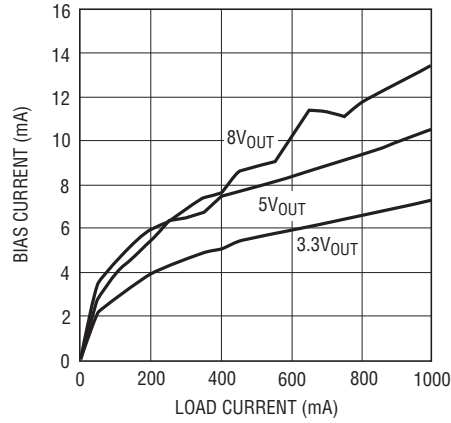

8022 G11

Minimum Required Input Voltage vs Output Load (8V_{OUT})

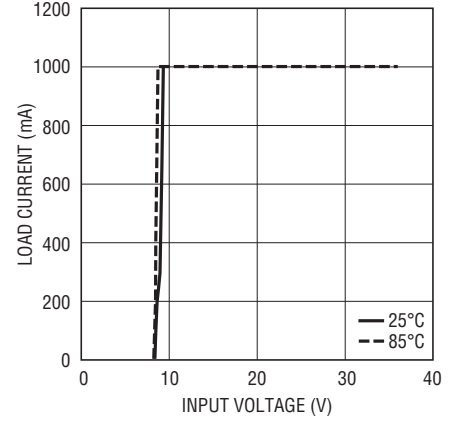

8022 G13

Minimum Required Input Voltage vs Output Load (5V_{OUT})

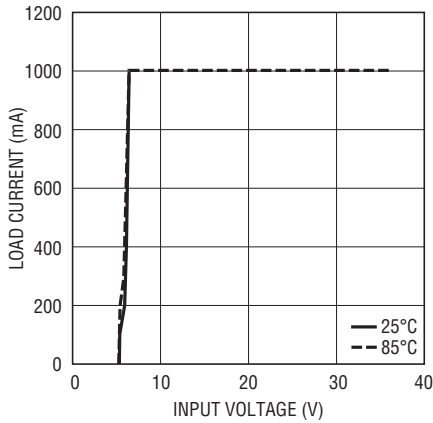

8022 G14

Minimum Required Input Voltage vs Output Load (3.3V_{OUT})

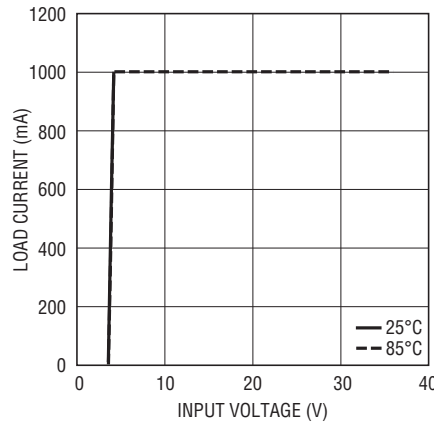

8022 G15

Temperature Rise vs Load (3.3V_{OUT})

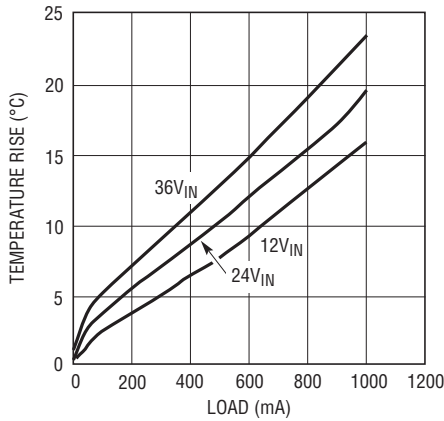

8022 G16

Temperature Rise vs Load (5V_{OUT})

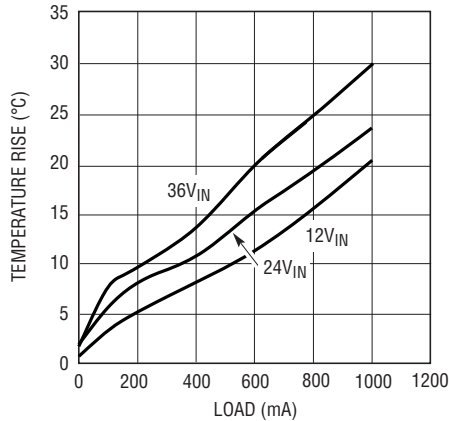

8022 G17

Temperature Rise vs Load (8V_{OUT})

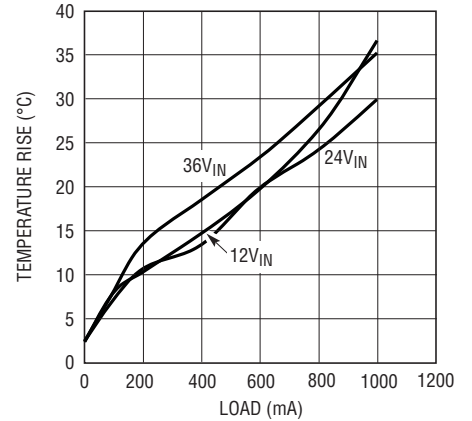

8022 G18

PIN FUNCTIONS

V_{IN} (Bank 1): The V_{IN} pin supplies current to the LTM8022's internal regulator and to the internal power switch. This pin must be locally bypassed with an external, low ESR capacitor of at least 2.2μF.

V_{OUT} (Bank 2): Power Output Pins. Apply the output filter capacitor and the output load between these pins and GND pins.

AUX (Pin F5): Low current voltage source for BIAS. In many designs, the BIAS pin is simply connected to V_{OUT}. The AUX pin is internally connected to V_{OUT} and is placed adjacent to the BIAS pin to ease printed circuit board routing. Although this pin is internally connected to V_{OUT}, do NOT connect this pin to the load. If this pin is not tied to BIAS, leave it floating. The Application Information section gives specific information about the BIAS and AUX connections

BIAS (Pin G5): The BIAS pin connects to the internal power bus. Connect to a power source greater than 2.4V. If the output is greater than 2.4V, connect this pin there. If the output voltage is less, connect this to a voltage source between 2.4V and 16V. Also, make sure that BIAS + V_{IN} is less than 56V.

RUN/SS (Pin H5): Tie RUN/SS pin to ground to shut down the LTM8022. Tie to 2.5V or more for normal operation. If the shutdown feature is not used, tie this pin to the V_{IN} pin. RUN/SS also provides a soft-start function; see the Applications Information section.

GND (Bank 3): Tie these GND pins to a local ground plane below the LTM8022 and the circuit components. Return the feedback divider (R_{ADJ}) to this pin.

R_T (Pin G7): The R_T pin is used to program the switching frequency of the LTM8022 by connecting a resistor from this pin to ground. The Applications Information section of the data sheet includes a table to determine the resistance value based on the desired switching frequency. Minimize capacitance at this pin.

SHARE (Pin F7): Tie this to the SHARE pin of another LTM8022 when paralleling the outputs. Otherwise, leave this pin floating.

SYNC (Pin G6): External Clock Synchronization Input. Ground this pin for low ripple Burst Mode® operation at low output loads, or connect to a stable voltage source above 0.7V to disable Burst Mode operation. **Do not leave this pin floating.** Tie to a clock source for synchronization. Clock edges should have rise and fall times faster than 1μs. See Synchronization in the Applications Information section.

PG (Pin H6): Open Collector Output of an Internal Comparator. PG remains low until the ADJ pin is within 10% of the final regulation voltage. PG output is valid when V_{IN} is above 3.6V and RUN/SS is high. If this function is not used, leave this pin floating.

ADJ (Pin H7): The LTM8022 regulates its ADJ pin to 0.79V. Connect the adjust resistor from this pin to ground. The value of R_{ADJ} is given by the equation, $R_{ADJ} = 394.21 / (V_{OUT} - 0.79)$, where R_{ADJ} is in kΩ.

APPLICATIONS INFORMATION

Table 1. Recommended Component Values and Configuration

V _{IN} *	V _{OUT}	C _{IN}	C _{OUT}	R _{ADJ}	B _{IAS}	f _{OPTIMAL} (kHz)	R _{T(OPTIMAL)}	f _{MAX} (kHz)	R _{T(MIN)}
3.6V to 36V	0.82V	2.2μF	247μF 1206	13M	≥2.4V, <16V	250	150k	250	150k
3.6V to 36V	1V	2.2μF	200μF 1206	1.87M	≥2.4V, <16V	300	124k	300	124k
3.6V to 36V	1.2V	2.2μF	100μF 1206	953k	≥2.4V, <16V	325	113k	325	113k
3.6V to 36V	1.5V	2.2μF	100μF 1206	549k	≥2.4V, <16V	375	93.1k	375	93.1k
3.6V to 36V	1.8V	2.2μF	68μF 1206	383k	≥2.4V, <16V	450	79k	450	79k
3.8V to 36V	2V	2.2μF	47μF 1206	324k	≥2.4V, <16V	475	73.2k	475	73.2k
3.8V to 36V	2.2V	2.2μF	47μF 0805	274k	≥2.4V, <16V	525	64.9k	525	64.9k
3.8V to 36V	2.5V	2.2μF	47μF 0805	226k	≥2.4V, <16V	575	59.0k	575	59.0k
4.75V to 36V	3.3V	2.2μF	22μF 0805	154k	AUX	750	42.2k	750	42.2k
6.8V to 36V	5V	2.2μF	4.7μF 1206	93.1k	AUX	1000	29.4k	1050	28.0k
11.5V to 36V	8V	2.2μF	4.7μF 0805	53.6k	AUX	1200	23.7k	1600	15.8k
3.6V to 15V	0.82V	2.2μF	200μF 1206	13M	V _{IN}	500	69.8k	615	54.9k
3.6V to 15V	1V	2.2μF	147μF 1206	1.87M	V _{IN}	615	54.9k	650	49.9k
3.6V to 15V	1.2V	2.2μF	100μF 1206	953k	V _{IN}	650	49.9k	750	42.2k
3.6V to 15V	1.5V	2.2μF	100μF 1206	549k	V _{IN}	700	44.2k	890	34.8k
3.6V to 15V	1.8V	2.2μF	68μF 1206	383k	V _{IN}	800	39.2k	1050	28.0k
3.6V to 15V	2V	2.2μF	47μF 1206	324k	V _{IN}	800	39.2k	1100	26.7k
3.6V to 15V	2.2V	2.2μF	47μF 0805	274k	V _{IN}	850	36.5k	1200	23.7k
3.6V to 15V	2.5V	2.2μF	47μF 0805	226k	V _{IN}	950	31.6k	1350	20.5k
4.75V to 15V	3.3V	2.2μF	22μF 0805	154k	AUX	950	31.6k	1725	14.3k
6.8V to 15V	5V	2.2μF	4.7μF 1206	93.1k	AUX	1150	25.5k	2400	7.87k
11.5V to 15V	8V	2.2μF	4.7μF 0805	53.6k	AUX	1200	23.7k	1900	12.1k
9V to 24V	0.82V	2.2μF	247μF 1206	13M	≥2.4V, <16V	375	93.1k	375	93.1k
9V to 24V	1V	2.2μF	200μF 1206	1.87M	≥2.4V, <16V	400	88.7k	400	88.7k
9V to 24V	1.2V	2.2μF	100μF 1206	953k	≥2.4V, <16V	450	79.0k	500	69.8k
9V to 24V	1.5V	2.2μF	100μF 1206	549k	≥2.4V, <16V	575	59.0k	575	59.0k
9V to 24V	1.8V	2.2μF	68μF 1206	383k	≥2.4V, <16V	650	49.9k	650	49.9k
9V to 24V	2V	2.2μF	47μF 0805	324k	≥2.4V, <16V	700	44.2k	700	44.2k
9V to 24V	2.2V	2.2μF	22μF 0805	274k	≥2.4V, <16V	775	41.2k	775	41.2k
9V to 24V	2.5V	2.2μF	22μF 0805	226k	≥2.4V, <16V	850	36.5k	850	36.5k
9V to 24V	3.3V	2.2μF	22μF 0805	154k	AUX	950	31.6k	1100	26.7k
9V to 24V	5V	2.2μF	4.7μF 1206	93.1k	AUX	1150	25.5k	1550	16.5k
11.5V to 24V	8V	2.2μF	4.7μF 0805	53.6k	AUX	1200	23.7k	2000	11.3k
18V to 24V	10V	2.2μF	2.2μF 0805	42.2k	AUX	1250	22.6k	1450	18.2k
18V to 36V	0.82V	2.2μF	247μF 1206	13M	≥2.4V, <16V	250	150k	250	150k
18V to 36V	1V	2.2μF	200μF 1206	1.87M	≥2.4V, <16V	300	124k	300	124k
18V to 36V	1.2V	2.2μF	100μF 1206	953k	≥2.4V, <16V	325	113k	325	113k
18V to 36V	1.5V	2.2μF	100μF 1206	549k	≥2.4V, <16V	375	93.1k	375	93.1k
18V to 36V	1.8V	2.2μF	68μF 1206	383k	≥2.4V, <16V	450	79k	450	79k
18V to 36V	2V	2.2μF	47μF 0805	324k	≥2.4V, <16V	475	73.2k	475	73.2k
18V to 36V	2.2V	2.2μF	22μF 0805	274k	≥2.4V, <16V	525	64.9k	525	64.9k
18V to 36V	2.5V	2.2μF	22μF 0805	226k	≥2.4V, <16V	575	59.0k	575	59.0k
18V to 36V	3.3V	2.2μF	22μF 0805	154k	AUX	750	42.2k	750	42.2k
18V to 36V	5V	2.2μF	4.7μF 1206	93.1k	AUX	1000	29.4k	1050	28.0k
18V to 36V	8V	2.2μF	4.7μF 0805	53.6k	AUX	1200	23.7k	1600	15.8k
18V to 36V	10V	2.2μF	2.2μF 0805	42.2k	AUX	1250	22.6k	1450	18.2k
4.75V to 32V	-3.3V	2.2μF	22μF 0805	154k	AUX	700	44.2k	775	41.2k
7V to 31V	-5V	2.2μF	10μF 0805	93.1k	AUX	1000	29.4k	1075	27.4k
13V to 28V	-8V	2.2μF	10μF 0805	53.6k	AUX	1100	26.7k	1350	20.5k

*Running voltage range. Please refer to Applications Information for start-up details.

APPLICATIONS INFORMATION

For most applications, the design process is straight forward, summarized as follows:

1. In Table 1, find the row that has the desired input voltage range and output voltage.
2. Apply the recommended C_{IN} , C_{OUT} , R_{ADJ} and R_T values.
3. Connect BIAS as indicated.

While these component combinations have been tested for proper operation, it is incumbent upon the user to verify proper operation over the intended system's line, load and environmental conditions.

If the desired output voltage is not listed in Table 1, set the output by applying an R_{ADJ} resistor whose value is given by the equation $R_{ADJ} = 394.21/(V_{OUT} - 0.79)$, where R_{ADJ} is in $k\Omega$ and V_{OUT} is in volts. Verify the LTM8022's operation over the system's intended line, load and environmental conditions.

Capacitor Selection Considerations

The C_{IN} and C_{OUT} capacitor values in Table 1 are the minimum recommended values for the associated operating conditions. Applying capacitor values below those indicated in Table 1 is not recommended, and may result in undesirable operation. Using larger values is generally acceptable, and can yield improved dynamic response, if it is necessary. Again, it is incumbent upon the user to verify proper operation over the intended system's line, load and environmental conditions.

Ceramic capacitors are small, robust and have very low ESR. However, not all ceramic capacitors are suitable. X5R and X7R types are stable over temperature and applied voltage and give dependable service. Other types, including Y5V and Z5U, have very large temperature and voltage coefficients of capacitance. In an application circuit they may have only a small fraction of their nominal capacitance, resulting in much higher output voltage ripple than expected.

Ceramic capacitors are also piezoelectric. In Burst Mode operation, the LTM8022's switching frequency depends on the load current, and can excite a ceramic capacitor at audio frequencies, generating audible noise. Since the LTM8022 operates at a lower current limit during Burst

Mode operation, the noise is typically very quiet to a casual ear.

If this audible noise is unacceptable, use a high performance electrolytic capacitor at the output. The input capacitor can be a parallel combination of a $2.2\mu F$ ceramic capacitor and a low cost electrolytic capacitor.

A final precaution regarding ceramic capacitors concerns the maximum input voltage rating of the LTM8022. A ceramic input capacitor combined with trace or cable inductance forms a high Q (under damped) tank circuit. If the LTM8022 circuit is plugged into a live supply, the input voltage can ring to twice its nominal value, possibly exceeding the device's rating. This situation is easily avoided; see the Hot-Plugging Safely section.

Frequency Selection

The LTM8022 uses a constant-frequency PWM architecture that can be programmed to switch from 200kHz to 2.4MHz by using a resistor tied from the R_T pin to ground. Table 2 provides a list of R_T resistor values and their resultant frequencies.

Table 2. Switching Frequency vs R_T Value

SWITCHING FREQUENCY (MHz)	R_T VALUE ($k\Omega$)
0.2	187
0.3	121
0.4	88.7
0.5	68.1
0.6	56.2
0.7	46.4
0.8	40.2
0.9	34
1.0	29.4
1.2	23.7
1.4	19.1
1.6	16.2
1.8	13.3
2.0	11.5
2.2	9.76
2.4	8.66

Operating Frequency Tradeoffs

It is recommended that the user apply the optimal R_T value given in Table 1 for the input and output operating condition. System level or other considerations, however, may necessitate another operating frequency. While the LTM8022 is flexible enough to accommodate a wide range

APPLICATIONS INFORMATION

of operating frequencies, a haphazardly chosen one may result in undesirable operation under certain operating or fault conditions. A frequency that is too high can reduce efficiency, generate excessive heat or even damage the LTM8022 if the output is overloaded or short-circuited. A frequency that is too low can result in a final design that has too much output ripple or too large of an output cap.

The maximum frequency and corresponding R_T value at which the LTM8022 should be allowed to switch is given in Table 1 in the $R_{T(MIN)}$ and f_{MAX} columns, while the recommended frequency and R_T value over the given input range is given in the $R_{T(OPTIMAL)}$ and $f_{OPTIMAL}$ columns.

There are additional conditions that must be satisfied if the synchronization function is used. Please refer to the Synchronization section for details.

Burst Mode Operation

To enhance efficiency at light loads, the LTM8022 automatically switches to Burst Mode operation which keeps the output capacitor charged to the proper voltage while minimizing the input quiescent current. During Burst Mode operation, the LTM8022 delivers single cycle bursts of current to the output capacitor followed by sleep periods where the output power is delivered to the load by the output capacitor. In addition, V_{IN} and BIAS quiescent currents are reduced to typically $20\mu A$ and $50\mu A$, respectively, during the sleep time. As the load current decreases towards a no load condition, the percentage of time that the LTM8022 operates in sleep mode increases and the average input current is greatly reduced, resulting in higher efficiency.

Burst Mode operation is enabled by tying SYNC to GND. To disable Burst Mode operation, tie SYNC to a stable voltage source above 0.7V. **Do not leave this pin floating.**

BIAS Pin Considerations

The BIAS pin is used to provide drive power for the internal power switching stage and operate internal circuitry. For proper operation, it must be powered by at least 2.4V. If the output voltage is programmed to be 2.4V or higher, simply tie BIAS to AUX, which is internally tied to V_{OUT} . If V_{OUT} is less than 2.4V, BIAS can be tied to V_{IN} or some other voltage source. In all cases, ensure that the

maximum voltage at the BIAS pin is less than 16V and the sum of $V_{IN} + BIAS$ is less than 56V. If BIAS power is applied from a remote or noisy voltage source, it may be necessary to apply a decoupling capacitor locally to the LTM8022.

Minimum Input Voltage

The LTM8022 is a step-down converter, so a minimum amount of headroom is required to keep the output in regulation. For most applications at full load, the input needs to be at least 1.5V above the desired output. In addition, the input voltage required to turn on depends upon how the RUN/SS pin is tied. As shown in Figure 1, it takes more input voltage to turn on if RUN/SS is tied to V_{IN} than if the turn-on is controlled by raising RUN/SS when V_{IN} is in the required operating range. This is shown in Figure 1.

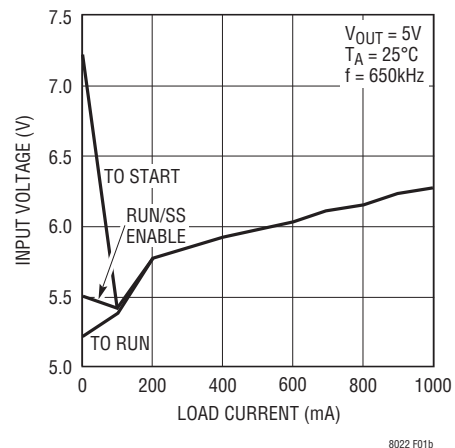
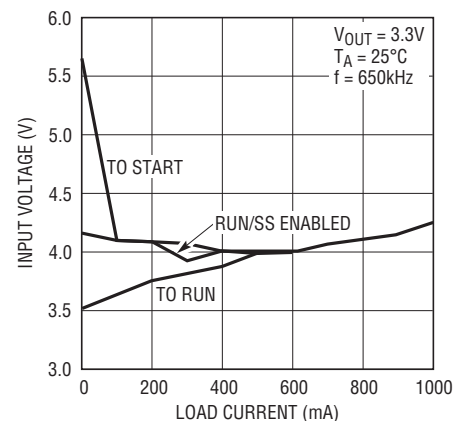

Figure 1. The LTM8022 Needs More Voltage to Start Than to Run

8022fd

APPLICATIONS INFORMATION

Load Sharing

Two or more LTM8022's may be paralleled to produce higher currents. To do this, tie the V_{IN} , V_{OUT} and SHARE pins of all the paralleled LTM8022's together. Synchronize the LTM8022s to avoid beat frequencies if required. To ensure that paralleled modules start up together, the RUN/SS pins may be tied together, as well. If the RUN/SS pins are not tied together, make sure that the same valued soft-start capacitors are used for each module. An example of two LTM8022 modules configured for load sharing is given in the Typical Applications section.

Soft-Start

The RUN/SS pin can be used to soft-start the LTM8022, reducing the maximum input current during start-up. The RUN/SS pin is driven through an external RC filter to create a voltage ramp at this pin. Figure 2 shows the start-up and shutdown waveforms with the soft-start circuit. By choosing an appropriate RC time constant, the peak start-up current can be reduced to the current that is required to regulate the output, with no overshoot. Choose the value of the resistor so that it can supply at least $20\mu\text{A}$ when the RUN/SS pin reaches 2.5V.

Synchronization

The internal oscillator of the LTM8022 can be synchronized by applying an external 250kHz to 2MHz clock signal to the SYNC pin. The resistor tied from the R_T pin to ground

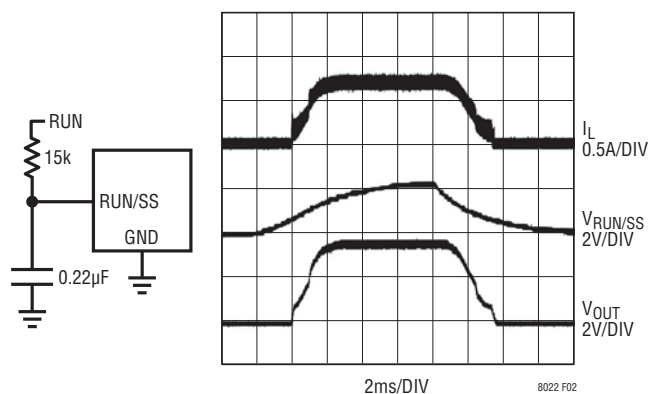

Figure 2. To Soft-Start the LTM8022, Add a Resistor and Capacitor to the RUN/SS Pin

should be chosen such that the LTM8022 would free run 20% lower than the intended synchronization frequency (see Frequency Selection section).

When the LTM8022 is synchronized to an external clock source, Burst Mode operation is disabled. The part will skip power switching cycles as necessary to maintain regulation. Ensure that the SYNC pin is not left floating. Tie it to GND if not used.

Shorted Input Protection

Care needs to be taken in systems where the output will be held high when the input to the LTM8022 is absent. This may occur in battery charging applications, or in battery backup systems where a battery or some other supply is diode ORed with the LTM8022's output. If the V_{IN} pin is allowed to float, and the RUN/SS pin is held high (either by a logic signal or because it is tied to V_{IN}), then the LTM8022's internal circuitry will pull its quiescent current through its internal power switch. This is fine if your system can tolerate a few milliamps in this state. If you ground the RUN/SS pin, the internal switch current will drop to essentially zero. However, if the V_{IN} pin is grounded while the output is held high, then parasitic diodes inside the LTM8022 can pull large currents from the output through the V_{IN} pin. Figure 3 shows a circuit that will run only when the input voltage is present and that protects against a shorted or reversed input.

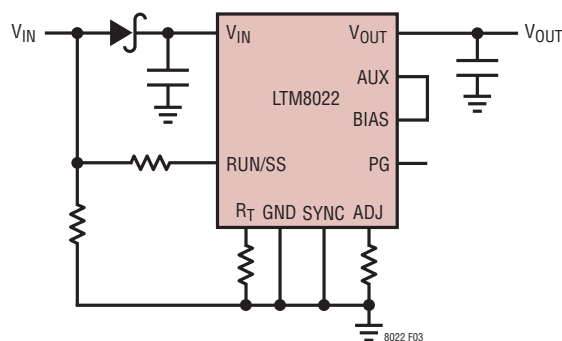

Figure 3. The Input Diode Prevents a Shorted Input from Discharging a Back-Up Battery Tied to the Output. It Also Protects the Circuit From a Reversed Input. The LTM8022 Runs Only When the Input is Present

APPLICATIONS INFORMATION

PCB Layout

Most of the headaches associated with PCB layout have been alleviated or even eliminated by the high level of integration of the LTM8022. The LTM8022 is nevertheless a switching power supply, and care must be taken to minimize EMI and ensure proper operation. Even with the high level of integration, you may fail to achieve specified operation with a haphazard or poor layout. See Figure 4 for a suggested layout.

Ensure that the grounding and heatsinking are acceptable. A few rules to keep in mind are:

1. Place the R_{ADJ} and R_T resistors as close to their respective pins as possible.
2. Place the C_{IN} capacitor as close as possible to the V_{IN} and GND connection of the LTM8022.
3. Place the C_{OUT} capacitor as close as possible to the V_{OUT} and GND connection of the LTM8022.
4. Place the C_{IN} and C_{OUT} capacitors such that their ground current flow directly adjacent or underneath the LTM8022.
5. Connect all of the GND connections to as large a copper pour or plane area as possible on the top layer. Avoid breaking the ground connection between the external components and the LTM8022.
6. Use vias to connect the GND copper area to the boards internal ground plane. Liberally distribute these GND vias to provide both a good ground connection and thermal path to the internal planes of the printed circuit board.

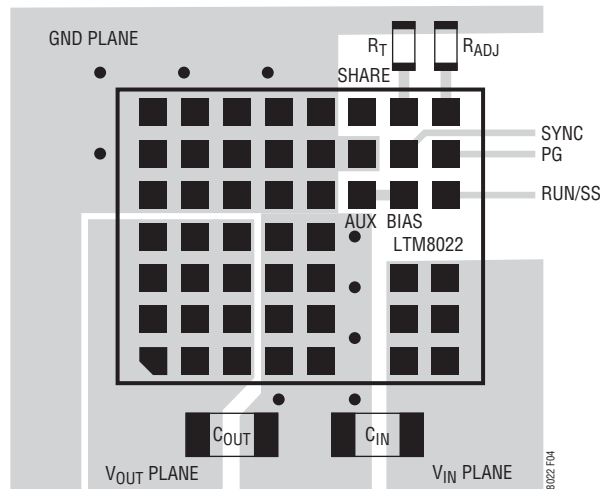

Figure 4. Layout Showing Suggested External Components, GND Plane and Thermal Vias

APPLICATIONS INFORMATION

Hot-Plugging Safely

The small size, robustness and low impedance of ceramic capacitors make them an attractive option for the input bypass capacitor of LTM8022. However, these capacitors can cause problems if the LTM8022 is plugged into a live supply (see Linear Technology Application Note 88 for a complete discussion). The low loss ceramic capacitor combined with stray inductance, in series with the power source, forms an underdamped tank circuit. In this case, the voltage at the V_{IN} pin of the LTM8022 can ring to twice the nominal input voltage, possibly exceeding the LTM8022's rating and damaging the part. If the input supply is poorly controlled or the user will be plugging the LTM8022 into an energized supply, the input network should be designed to prevent this overshoot. Figure 5 shows the waveforms that result when an LTM8022 circuit is connected to a 24V supply through six feet of 24-gauge twisted pair. The first plot is the response with a 2.2 μ F ceramic capacitor at the input. The input voltage rings as high as 35V and the input current peaks at 20A. One method of damping the tank circuit is to add another capacitor with a series resistor to the circuit. In Figure 5b an aluminum electrolytic capacitor has been added. This capacitor's high equivalent series resistance damps the circuit and eliminates the voltage overshoot. The extra capacitor improves low frequency ripple filtering and can slightly improve the efficiency of the circuit, though it is likely to be the largest component in the circuit. An alternative solution is shown in Figure 5c. A 0.7 Ω resistor is added in series with the input to eliminate the voltage overshoot (it also reduces the peak input current). A 0.1 μ F capacitor improves high frequency filtering. This solution is smaller and less expensive than the electrolytic capacitor. For high input voltages its impact on efficiency is minor, reducing efficiency less than one half percent for a 5V output at full load operating from 24V.

Thermal Considerations

The LTM8022 output current may need to be derated if it is required to operate in a high ambient temperature or deliver a large amount of power. The amount of current derating is dependent upon the input voltage, output power and ambient temperature. The derating curves in the Typical Performance Characteristics section can be used as a guide. These curves were generated by an LTM8022 mounted to a 33cm² 4-layer FR4 printed circuit board. Boards of other sizes and layer count can exhibit different thermal behavior, so it is incumbent upon the user to verify proper operation over the intended system's line, load and environmental operating conditions.

The junction to air and junction to board thermal resistances given in the Pin Configuration diagram may also be used to estimate the LTM8022 internal temperature. These thermal coefficients are determined per JEDEC 51-9 (JEDEC standard, test boards for area array surface mount package thermal measurements) through analysis and physical correlation. Bear in mind that the actual thermal resistance of the LTM8022 to the printed circuit board depends upon the design of the circuit board. The die temperature of the LTM8022 must be lower than the maximum rating of 125°C, so care should be taken in the layout of the circuit to ensure good heat sinking of the LTM8022.

The bulk of the heat flow out of the LTM8022 is through the bottom of the module and the LGA pads into the printed circuit board. Consequently a poor printed circuit board design can cause excessive heating, resulting in impaired performance or reliability. Please refer to the PCB Layout section for printed circuit board design suggestions.

Finally, be aware that at high ambient temperatures the internal Schottky diode will have significant leakage current (see Typical Performance Characteristics) increasing the quiescent current of the LTM8022.

APPLICATIONS INFORMATION

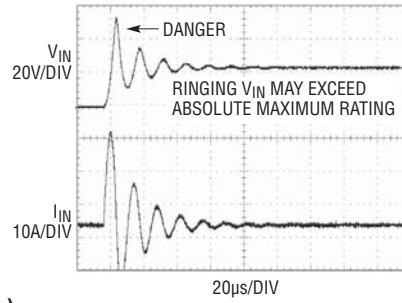
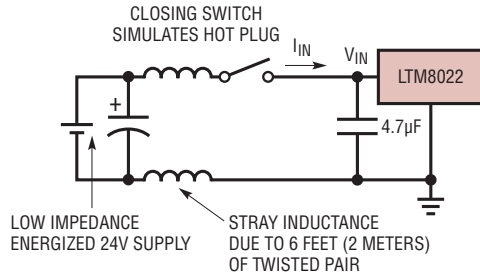

(5a)

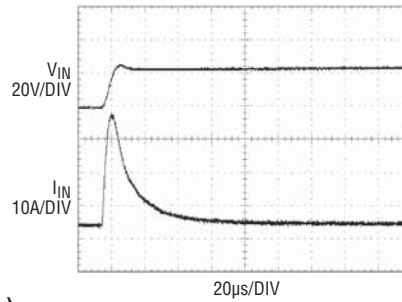
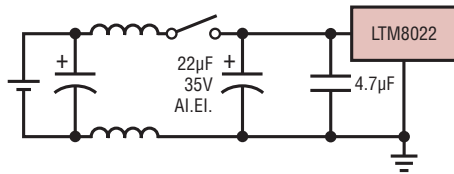

(5b)

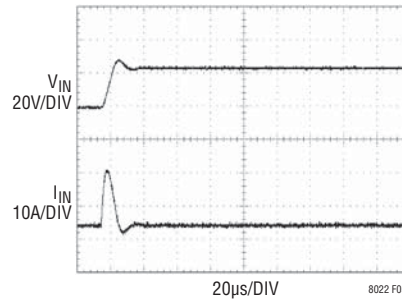
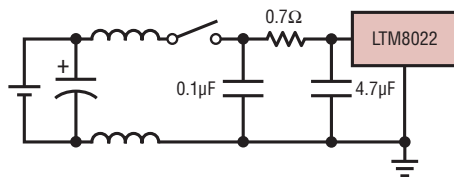

(5c)

Figure 5. A Well Chosen Input Network Prevents Input Voltage Overshoot and Ensures Reliable Operation When the LTM8022 is Connected to a Live Supply

TYPICAL APPLICATIONS

0.82V Step-Down Converter

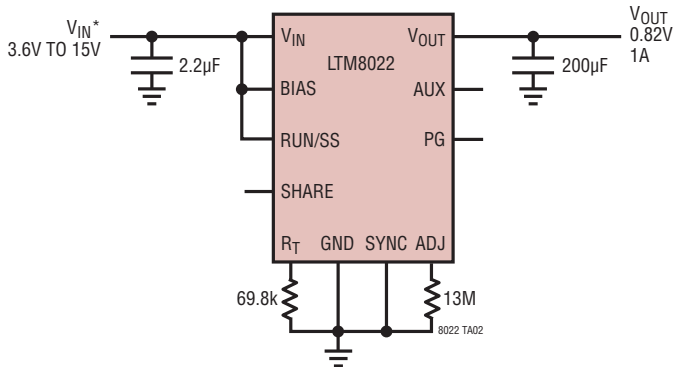

*RUNNING VOLTAGE RANGE. PLEASE REFER TO APPLICATIONS INFORMATION FOR START-UP DETAILS

1.8V Step-Down Converter

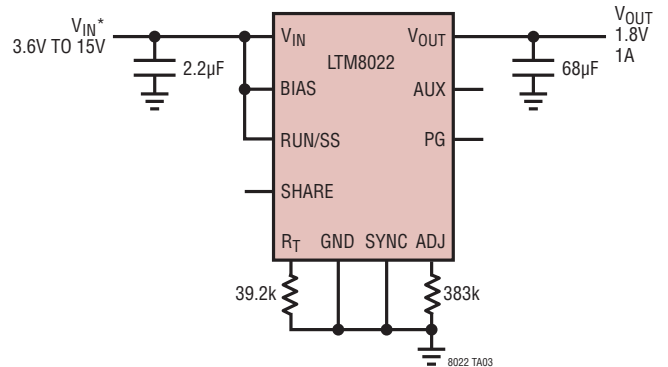

*RUNNING VOLTAGE RANGE. PLEASE REFER TO APPLICATIONS INFORMATION FOR START-UP DETAILS

2.5V Step-Down Converter

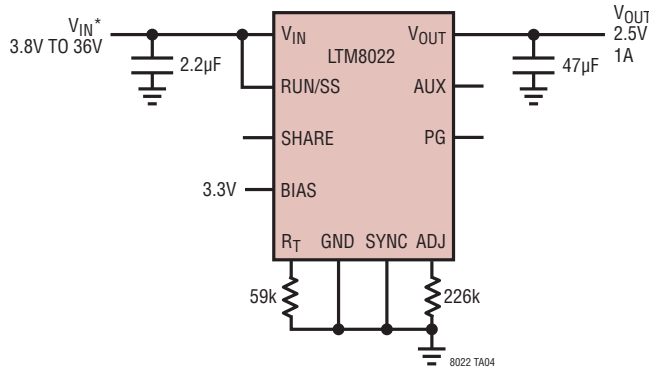

*RUNNING VOLTAGE RANGE. PLEASE REFER TO APPLICATIONS INFORMATION FOR START-UP DETAILS

-5V at 1A Positive-to-Negative Converter

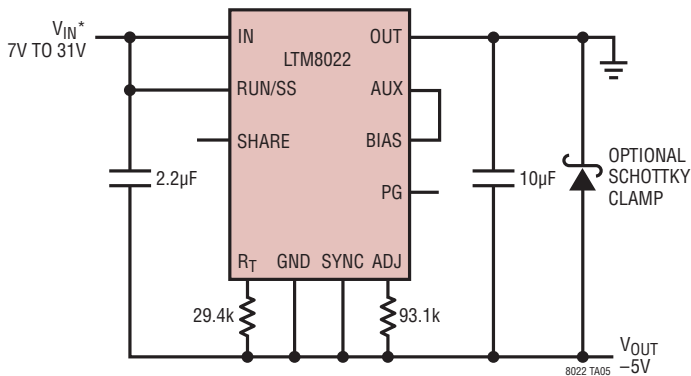

*RUNNING VOLTAGE RANGE. PLEASE REFER TO APPLICATIONS INFORMATION FOR START-UP DETAILS

-5V at 1A Positive-to-Negative Converter Load Current vs Input Voltage

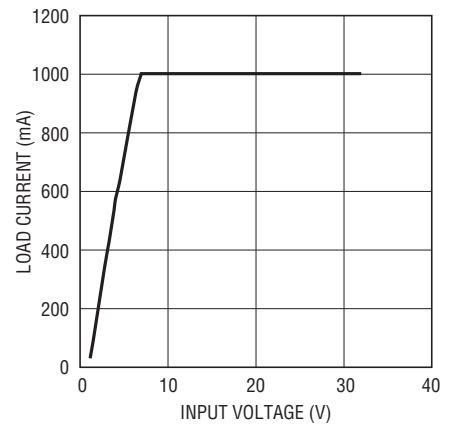

8022 TA05b

TYPICAL APPLICATIONS

Two LTM8022's in Parallel, 3.3V at 1.8A

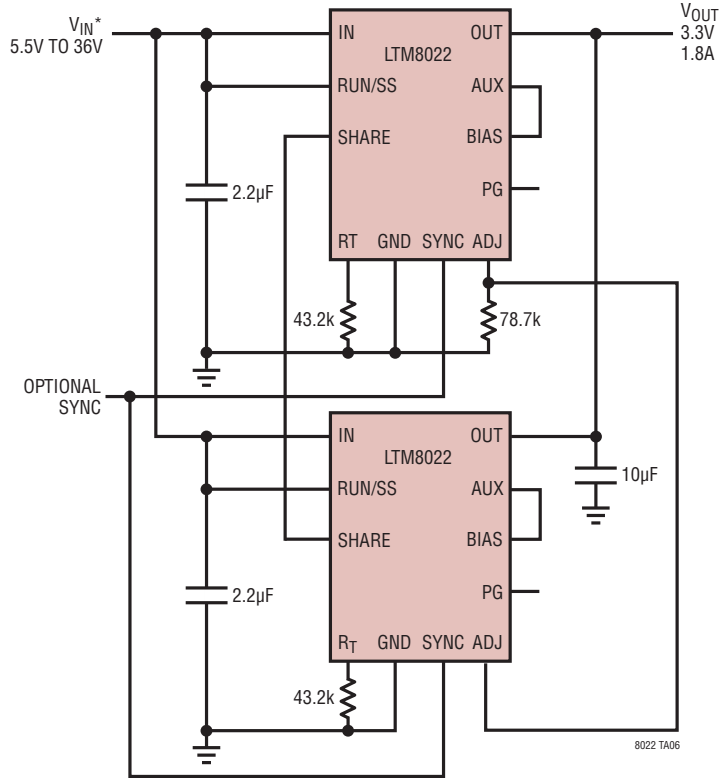

*RUNNING VOLTAGE RANGE. PLEASE REFER TO APPLICATIONS INFORMATION FOR START-UP DETAILS
 NOTE: SYNCHRONIZE THE TWO MODULES TO AVOID BEAT FREQUENCIES IF REQUIRED. OTHERWISE, TIE EACH SYNC TO GND

PACKAGE DESCRIPTION

LGA Package
50-Lead (11.25mm × 9.00mm × 2.82mm)
 (Reference LTC DWG # 05-08-1804 Rev B)

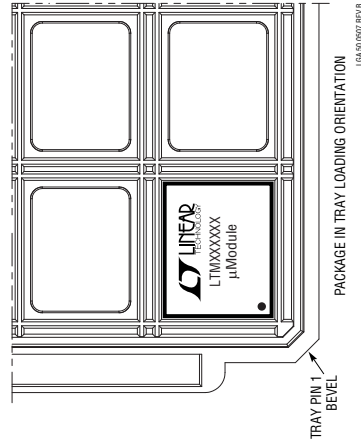
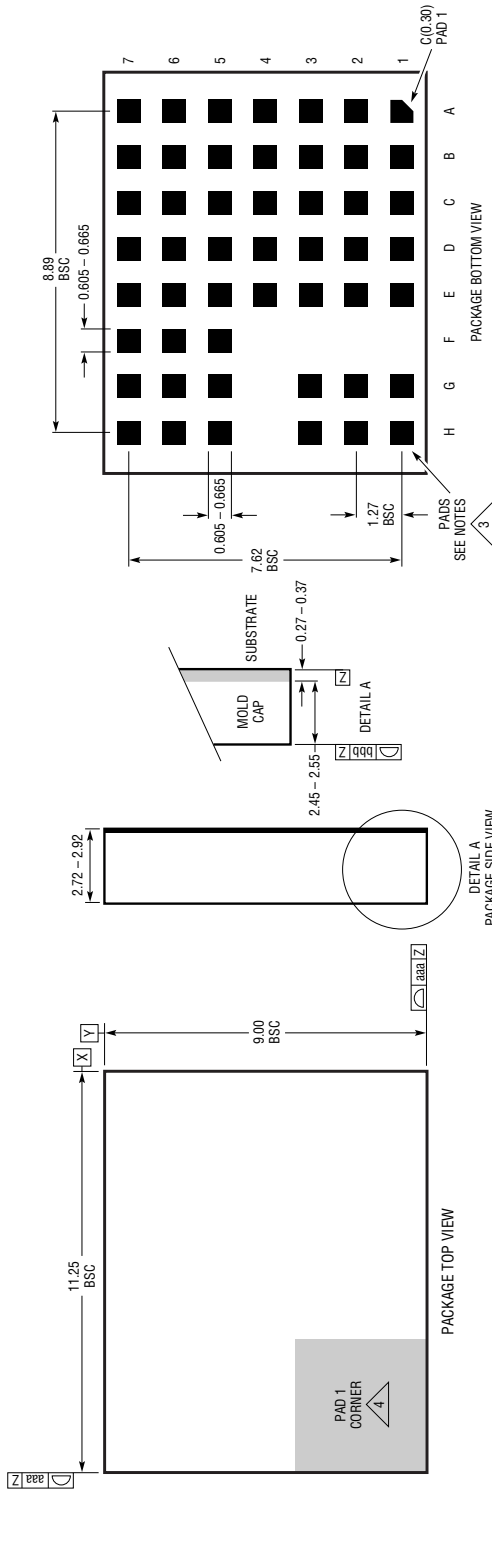

- NOTES:
1. DIMENSIONING AND TOLERANCING PER ASME Y14.5M-1994
 2. ALL DIMENSIONS ARE IN MILLIMETERS
 3. LAND DESIGNATION PER JEDEC MO-222, SPP-010 AND SPP-020
 4. DETAILS OF PAD #1 IDENTIFIER ARE OPTIONAL, BUT MUST BE LOCATED WITHIN THE ZONE INDICATED. THE PAD #1 IDENTIFIER MAY BE EITHER A MOLD OR A MARKED FEATURE
 5. PRIMARY DATUM -Z- IS SEATING PLANE
 6. THE TOTAL NUMBER OF PADS: 50

SYMBOL	TOLERANCE
aaa	0.15
bbb	0.10

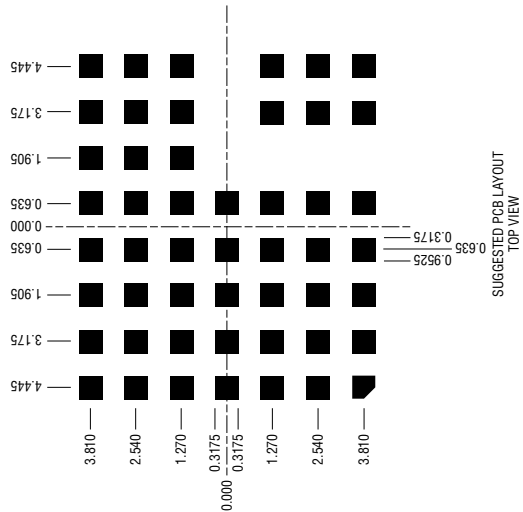

PACKAGE DESCRIPTION

Table 3. LTM8022 Pinout (Sorted by Pin Number)

PIN	SIGNAL DESCRIPTION	PIN	SIGNAL DESCRIPTION
A1	V _{OUT}	D5	GND
A2	V _{OUT}	D6	GND
A3	V _{OUT}	D7	GND
A4	V _{OUT}	E1	GND
A5	GND	E2	GND
A6	GND	E3	GND
A7	GND	E4	GND
B1	V _{OUT}	E5	GND
B2	V _{OUT}	E6	GND
B3	V _{OUT}	E7	GND
B4	V _{OUT}	F5	AUX
B5	GND	F6	GND
B6	GND	F7	SHARE
B7	GND	G1	V _{IN}
C1	V _{OUT}	G2	V _{IN}
C2	V _{OUT}	G3	V _{IN}
C3	V _{OUT}	G5	BIAS
C4	V _{OUT}	G6	SYNC
C5	GND	G7	R _T
C6	GND	H1	V _{IN}
C7	GND	H2	V _{IN}
D1	GND	H3	V _{IN}
D2	GND	H5	RUN/SS
D3	GND	H6	PG
D4	GND	H7	ADJ

REVISION HISTORY (Revision history begins at Rev D)

REV	DATE	DESCRIPTION	PAGE NUMBER
D	8/10	Added Note 5	3

LTM8022

TYPICAL APPLICATION

3.3V Step Down Converter

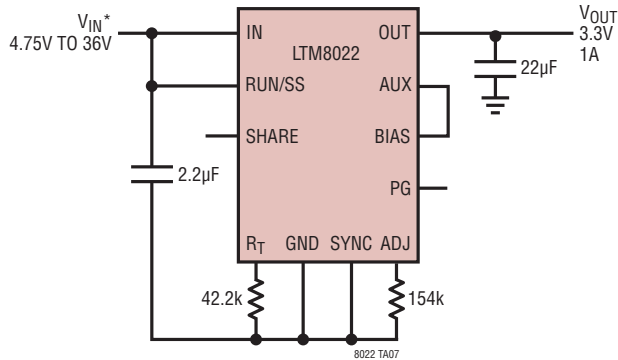

*RUNNING VOLTAGE RANGE. PLEASE REFER TO APPLICATIONS INFORMATION FOR START-UP DETAILS

RELATED PARTS

PART NUMBER	DESCRIPTION	COMMENTS
LTM4600/LTM4602	10A and 6A DC/DC µModule	Pin Compatible, $4.5V \leq V_{IN} \leq 28V$
LTM4601/LTM4603	12A and 6A DC/DC µModule	Pin Compatible; Remote Sensing; PLL, Tracking and Margining, $4.5V \leq V_{IN} \leq 28V$
LTM4604/LTM4608	4A, 8A Low Voltage DC/DC µModule	$2.375V \leq V_{IN} \leq 5.5V$, 9mm × 15mm × 2.3mm (LTM4604), 9mm × 15mm × 2.5mm (LTM4608)
LTM4605/LTM4607	Buck-Boost DC/DC µModule	Up to 160W, External Inductor; High Efficiency (Up to 98%), 15mm × 15mm × 2.8mm LGA
LTM8020	200mA, 36V DC/DC µModule	$4V \leq V_{IN} \leq 36V$, $1.25V \leq V_{OUT} \leq 5V$, 6.25mm × 6.25mm × 2.32mm LGA
LTM8023	2A, 36V DC/DC µModule	$3.6V \leq V_{IN} \leq 36V$, $0.8V \leq V_{OUT} \leq 10V$, 11.25mm × 9mm × 2.82mm LGA, Pin Compatible with LTM8022

8022fd

Looking for pricing, stock, or lifecycle information?

Click below to explore more details on WIN SOURCE:

 [View LTM8022EV#PBF\(LTM8022V\) on WIN SOURCE](#)

 [Linear Technology](#) Information

Optimize Your Supply Chain with WIN SOURCE Solutions

-  Global Sourcing Solution
-  Obsolete Management
-  Cost Control Management
-  Shortage Management
-  Alternative Solution
-  Excess Inventory Management